



Publication Year	2009
Acceptance in OA @INAF	2023-02-14T16:59:47Z
Title	Planck sorption cooler system user manual
Authors	MORGANTE, GIANLUCA
Handle	http://hdl.handle.net/20.500.12386/33463
Number	PL-LFI-PST_MA_002



TITLE: Sorption Cooler System *User Manual*



DOC. TYPE: USER MANUAL

PROJECT REF.: PL-LFI-PST-MA-002

PAGES: 365

ISSUE/REV.: 3.0

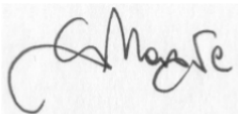
DATE: 20 March 2009

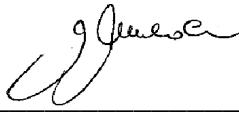
Prepared by	G. MORGANTE LFI - Project System Team SCS – AIV & Op Manager	Date: 20.03.2009 Signature: 
Agreed by	C. BUTLER LFI - Program Manager	Date: 20.03.2009 Signature: 
Approved by	N. MANDOLESI LFI - Principal Investigator	Date: 20.03.2009 Signature: 

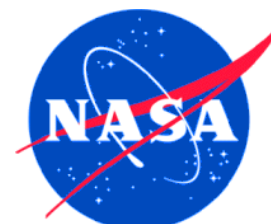



DISTRIBUTION LIST

Recipient	Company/Institute	E-mail address
L. PEREZ CUEVAS	ESA – ESTEC	Leticia.Pereze.Cuevas@esa.int
O. PIERSANTI	ESA – ESTEC	Osvaldo.Piersanti@esa.int
C. DAMASIO	ESA – ESTEC	Claudio.Damasio@esa.int
P. OLIVIER	ESA – ESTEC	Pierre.Olivier@esa.int
C. WATSON	ESA – ESOC	Chris.Watson@esa.int
S. FOLEY	ESOC – Darmstadt	Steve.Foley@esa.int
PGSSG	Ground Segment WG	pgssg@rssd.esa.int
ICWG	Instrum. Coord. WG	icwg@rssd.esa.int
COWG	Cryo Ops WG	cowg@rssd.esa.int
B. COLLAUDIN	AAS – Cannes	Bernard.Collaudin@thalesalieniaspace.com
J.P. CHAMBELLAND	AAS – Cannes	jean-philippe.chambelland@thalesalieniaspace.com
P. RIHET	AAS – Cannes	Patrick.Rihet@thalesalieniaspace.com
G. GUYOT	IAS – Orsay	Guy.Guyot@ias.u-psud.fr
T. MACIASZEK	IAS – Orsay	thierry.maciaszek@ias.u-psud.fr
M. CHARRA	IAS – Orsay	Maryse.Charra@ias.u-psud.fr
L. VIBERT	IAS – Orsay	laurent.vibert@ias.u-psud.fr
D. SANTOS	LPSC - Grenoble	Daniel.Santos@lpsc.in2p3.fr
P. STASSI	LPSC - Grenoble	stassi@lpsc.in2p3.fr
F. MELOT	LPSC - Grenoble	frederic.melot@lpsc.in2p3.fr
D. PEARSON	JPL – Pasadena	David.P.Pearson@jpl.nasa.gov
U. ISRAELSSON	JPL – Pasadena	Ulf.E.Israelsson@jpl.nasa.gov
C. BUTLER	IASF – Bologna	butler@iasfbo.inaf.it
LFI System PCC	IASF – Bologna	lfispcc@iasfo.inaf.it
A. GREGORIO	UniTS – Trieste	anna.gregorio@ts.infn.it
L. TERENCE	IASF – Bologna	terenzi@iasfbo.inaf.it
A. ZACCHEI	OATS – Trieste	zacchei@oats.inaf.it
M. FRAILIS	OATS – Trieste	frailis@oats.inaf.it



CHANGE RECORD

Issue	Date	Sheet	Description of Change
0.1		All	First Draft of Document
0.3	31.08.2005	All	Second Draft of Document
1.0		All	First Issue of Document, general rewriting
2.0	14.08.2008	All.	Comments, RIDs, Procedures included
"	"	Ch.7	Revision of SCE FMECA
"	"	Ch.8	Chapter update
"	"	Ch.10	Chapter update
"	"	Ch.9	Update and addition of procedures
3.0	20.03.2009	Ch.5	Updated table
"	"	Ch.6	Boot and Init Mode, Defrost State, paragraphs update
"	"	Ch.7	FDIR Table Update, chapter formatting review
"	"	Ch.8	Memory & ASW upload info updated
"	"	Ch.9	New contingency procs added, Healthcheck proc update
"	"	Ch.10	Update in TM(5) definition and Memory/ASW upload info
"	"	App.1	Update in LUT definition and values
"	"	App.2	Updated Sensors and Heaters table
"	"	App.3	Added Appendix on MIB User Guide



TABLE OF CONTENTS

LIST OF ACRONYMS	11
APPLICABLE & REFERENCED DOCUMENTS	15
Applicable Documents.....	15
Referenced Documents.....	15
1. PLANCK SCS DESCRIPTION.....	17
1.1. THE PLANCK SORPTION COOLER SYSTEM	17
1.2. THE PLANCK SORPTION COOLER PRINCIPLE OF OPERATION	19
1.3. SCS THERMO-MECHANICAL UNIT (TMU)	22
1.4. THE SORPTION COOLER ELECTRONICS (SCE) DESCRIPTION	22
2. PLANCK SORPTION COOLER SYSTEM CONFIGURATION.....	24
2.1. PLANCK SCS HIERARCHICAL CONFIGURATION	24
2.2. SCS THERMO-MECHANICAL UNIT (TMU) CONFIGURATION	24
2.2.1. TMU Mechanical Configuration	26
2.2.1.1. Sorption Cooler Compressor (SCC) assembly	26
2.2.1.2. Piping Assembly and Cold End (PACE)	28
2.2.1.3. TMU Heaters and Sensors	31
2.2.2. SCE Configuration	34
3. PLANCK SORPTION COOLER SYSTEM FUNCTIONS.....	36
3.1. TMU FUNCTIONS.....	36
3.1.1. Sorption Cooler Compressor (SCC) assembly	36
3.1.2. PACE Functions	39
3.2. SCE FUNCTIONS	40
3.2.1. Sensors acquisition.....	44
3.2.1.1. Pressure sensors acquisition diagram	44
3.2.1.2. Temperature sensors acquisition diagram.....	45
3.2.1.2.1. Thermocouples	45
3.2.1.2.2. RTD Sensors	45
3.2.1.3. Read Out acquisition diagram.....	47
3.2.2. Power Handling	47
3.2.2.1. Power Distribution.....	47
3.2.2.2. Power Control	48
3.2.2.2.1. Compressor Heaters.....	48
3.2.2.2.2. Others Heaters.....	49
4. PLANCK SORPTION COOLER SYSTEM INTERFACES.....	50
4.1. SCS INTERFACES WITH THE SPACECRAFT	50
4.2. TMU MECHANICAL INTERFACES	51
4.2.1. On SVM	51
4.2.2. On Planck P/L Module (PPLM).....	51
4.2.2.1. Cooler and Piping	51
4.3. TMU THERMAL INTERFACES.....	52
4.3.1. On SVM	53
4.3.2. On Planck P/L Module (PPLM).....	53
4.3.2.1. Planck module «Cold»	53
4.3.2.2. Interface temperatures at the HFI/LFI FPU.....	54



4.3.3.	Temperature channels.....	54
4.4.	POWER INTERFACES.....	55
4.4.1.	On SVM	55
4.4.1.1.	Radiator Temperature Stability	57
4.4.2.	On Planck Module (PPLM)	59
4.4.3.	Supply Voltages.....	59
4.5.	CONNECTOR, HARNESS & GROUNDING	60
4.5.1.	Connectors list (on equipment side)	60
4.5.2.	Harness	62
4.5.2.1.	SCS - S/C Harness	63
4.5.2.1.1.	Communication bus (1553B) and On Board Clock Synch	64
4.5.2.1.2.	Power Supply pin out connectors:	64
4.5.2.1.3.	SCE 1553B address connector.....	65
4.5.2.2.	Sorption Cooler Subsystem Harness.....	66
4.5.2.2.1.	Sorption Cooler Subsystem Harness on SVM	66
4.5.2.2.2.	Cryo Harness	74
4.5.2.2.3.	Connectors reference specifications.....	79
4.5.2.2.4.	Cables reference specifications	81
4.6.	SCS GROUNDING	82
5.	PLANCK SCS PERFORMANCE	83
5.1.	COLD END TEMPERATURE	84
5.2.	TEMPERATURE STABILITY	84
5.3.	COOLING CAPACITY	85
5.4.	HEAT LIFT ADAPTABILITY	85
5.5.	LIFETIME	85
5.6.	REGENERATION	85
5.7.	COOL DOWN.....	86
5.8.	MEASURED PERFORMANCE.....	86
6.	SORPTION COOLER SYSTEM OPERATIONS MODES	87
6.1.	PLANCK SCS OPERATIONS	87
6.1.1.	Required Operational Capabilities	87
6.1.1.1.1.	Nominal/Steady-State Operation	87
6.1.1.1.2.	Cooler Startup.....	87
6.1.1.1.3.	Plug Detection and Removal	88
6.1.2.	Cooler Operational Scheme	88
6.1.2.1.1.	Top-Level Description of Cooler Operation.....	88
6.1.2.1.2.	Ready Mode.....	89
6.1.2.1.3.	Run Mode	89
6.1.2.1.4.	Conditioning State.....	90
6.1.2.1.5.	Normal State	92
6.1.2.1.6.	Fault detection and response.....	92
6.1.2.1.7.	J-T plug detection and recovery.....	92
6.2.	SCS OPERATION MODES.....	95
6.2.1.	BOOT Mode.....	97
6.2.2.	INIT Mode	97
6.2.3.	READY Mode	98
6.2.3.1.	Health Monitoring.....	98
6.2.3.2.	Health Monitoring Procedure	98
6.2.3.3.	Healthcheck	99
6.2.3.3.1.	Healthcheck Procedure.....	99
6.2.4.	RUN MODE: an overview	100



6.2.4.1.	Conditioning State.....	101
6.2.4.2.	Defrost Process	102
6.2.4.3.	NORMAL State	103
6.2.4.4.	SHUTDOWN MODE	105
7.	PLANCK SORPTION COOLER SYSTEM FAILURES	107
7.1.	TMU FAILURE ANALYSIS	107
7.2.	SCE FAILURE ANALYSIS	119
7.2.1.	SCE FMECA.....	119
7.2.2.	Sensor Acquisition (PLDBB0) FMEA.....	121
7.2.3.	Power Handling (PLDBC0) FMEA	121
7.2.4.	SCE components critical analysis.....	122
7.2.5.	Critical Analysis conclusions.....	124
7.3.	SCE HW AND SW INTERACTION ANALYSIS (HSIA)	125
7.3.1.1.	Philosophy	125
7.3.1.1.1.	Failures descriptions	125
7.3.1.1.2.	Software Action on Failures (SCE internal FDIR)	125
7.3.1.1.3.	Reading chain failures	125
7.3.1.1.4.	Sensors Failures	126
7.3.1.1.5.	Beds.....	126
7.3.1.1.6.	Other Sensors.....	127
7.3.1.1.7.	Heaters failures.....	128
7.3.1.1.8.	Actions on Electronics failures	130
7.3.1.1.9.	Critical parts failures	130
7.3.1.1.10.	Power failures	132
7.3.1.1.11.	Actions for safety	132
7.3.1.1.12.	Operational actions	133
7.3.1.1.13.	External FDIR	134
7.3.1.1.14.	Service 5 telemetry Event Report TM(5,1).....	135
8.	SORPTION COOLER SYSTEM ON-BOARD SOFTWARE.....	136
8.1.	INTRODUCTION	136
8.2.	INSTRUCTION.....	137
8.2.1.	First launch: set the lookup table and applicative software	137
8.2.2.	Applicative Software Structure in EEPROM	140
8.2.3.	Diagram of the memories	141
8.3.	REFERENCE	142
8.3.1.	List of operations	142
8.3.2.	Telecommand Report	143
8.3.3.	Housekeeping and Diagnostic Report	143
8.3.4.	Event Report.....	148
8.3.5.	Time Management.....	149
8.3.6.	Report Enabled Telemetry	150
8.3.7.	Link Report	151
8.3.8.	Memory Operation: Memory Load	151
8.3.9.	Memory Operation: Memory Dump	152
8.3.10.	Memory Operation: Memory Check.....	152
8.3.11.	Hardware Test: test PM PROM	153
8.3.12.	Hardware Test: test PM RAM (BSW ONLY).....	155
8.3.13.	Hardware Test: test DM RAM (BSW ONLY)	156
8.3.14.	Hardware Test: test DM EEPROM	158
8.3.15.	Hardware Test: test FPGA (BSW ONLY)	160
8.3.16.	Hardware Test: test 1553 (BSW ONLY)	160



8.3.17.	Hardware Test: test external timers (ASW ONLY)	160
8.3.18.	Hardware Test: test ADC (ASW ONLY)	160
8.3.19.	Applicative Software Transfer (BSW ONLY).....	161
8.3.20.	Stop Process	163
8.3.21.	Mode Change telecommands.....	164
8.3.22.	Operations available on all modes.....	165
8.3.23.	Boot Mode Description	166
8.3.24.	Init Mode Description	168
8.3.25.	Ready Mode Description	171
8.3.26.	Run Mode Description	175
8.3.27.	SHUTDOWN Mode Description.....	184
8.3.28.	Set Initial Bed Position telecommand	185
8.3.29.	Return to Initial Bed State telecommand	185
8.3.30.	Set Bed State telecommand	185
8.3.31.	Set Device State telecommand	186
8.3.32.	Sensors acquisition.....	187
8.3.33.	EEPROM configuration.....	188
8.3.34.	Lookup table	191
8.3.35.	FDIR	192
8.3.35.1.	FDIR: Reading Chains Failure (ASW only).....	193
8.3.35.2.	FDIR: Sensors Failures (ASW only)	193
8.3.35.3.	FDIR: Heaters Failures (ASW only).....	193
8.3.35.4.	FDIR: Critical Parts Failures	195
8.3.35.5.	FDIR: Power Failures (ASW only)	195
8.3.35.6.	FDIR: Actions for Safety (ASW only)	196
8.3.35.7.	FDIR: Operational actions (ASW only)	196
8.4.	BED TEMPERATURE CALCULATION	196
8.5.	ASW PROCESSES DESCRIPTION.....	198
8.5.1.	The Health Check procedure.....	198
8.5.1.1.	OBJECTIVE	198
8.5.1.2.	THE PROCEDURE.....	198
8.5.2.	The Regeneration procedure.....	200
8.5.3.	The PID algorithm.....	201
8.5.4.	The OPEN LOOP algorithm.....	202
8.5.5.	The BAD BED DETECTION algorithm	203
8.6.	THE LOOKUP TABLE	205
9.	PLANCK SCS OPERATION PROCEDURES.....	206
9.1.	SCS PROCEDURE BLOCKS	206
9.1.1.	SCE BOOT (BOOT).....	208
9.1.2.	SCS INIT (INIT)	208
9.1.3.	LUT Upload (LUT_UP)	210
9.1.4.	LUT Dump (LUT_DU).....	211
9.1.5.	READY – HealthMonitoring (READY_HM).....	212
9.1.6.	READY – HealthCheck (READY_HC).....	212
9.1.7.	SCS RUN (RUN)	214
9.1.8.	SCS Shutdown (SHUTDOWN).....	214
9.2.	SCS OPERATING PROCEDURES	216
9.2.1.	SCS Nominal Procedures.....	216
9.2.1.1.	System Initialization (SCE_INIT).....	216
9.2.1.2.	SCS in HealthMonitoring (READY_HM)	216
9.2.1.3.	Execute SCS HealthCheck (READY_HC)	217
9.2.1.4.	Cooler Start-up (START_UP)	217



9.2.1.5.	SCS Cooldown Process.....	218
9.2.1.6.	SCS Switch Off (SWITCH_OFF)	218
9.2.2.	SCS Contingency Procedures	219
9.2.2.1.	Manual Defrost Procedure (DEFROST)	219
9.2.2.2.	Regeneration Procedure (REGEN).....	220
9.2.2.3.	Switchover Process (SWITCHOVER).....	221
9.2.2.4.	Set Bed State (BED_STATE)	223
9.2.2.5.	Set Device State (DEV_STATE).....	223
9.2.2.6.	Set Initial Heatup Bed Position (SET_INITIAL_BED)	224
9.2.2.7.	Return to Initial Bed States (RETURN_TO_INITIAL_BED)	224
9.2.2.8.	Transition into Shutdown Mode (SHUTDOWN).....	225
10.	PLANCK SCS TELEMETRY & TELECOMMAND DATA	226
10.1.	PURPOSE AND SCOPE	226
10.2.	GENERAL TM/TC STRUCTURE	226
10.2.1.	TC structure	226
10.2.2.	TM structure.....	227
10.3.	TM/TC SPECIFIC FIELDS.....	228
10.3.1.	TM(1,1): Telecommand Acceptance Report : Success	228
10.3.2.	TM(1,2): Telecommand Acceptance Report : Failure	228
10.3.3.	TM(1,3): Telecommand Execution Report : Started	229
10.3.4.	TM(1,7): Telecommand Execution Report : Completed.....	229
10.3.5.	TM(1,8): Telecommand Execution Report : Failure	229
10.3.6.	TM(3,25): Housekeeping Parameter Report.....	230
10.3.7.	TM(3,26): Diagnostic Parameter Report.....	234
10.3.8.	TM(5,1): Event Report	238
10.3.9.	TM(5,2): Exception Report.....	239
10.3.10.	TM(5,4): Error Report.....	239
10.3.11.	TC(6,2): Load Memory Using Absolute Address	240
10.3.12.	TC(6,5): Dump Memory Using Absolute Address.....	241
10.3.13.	TC(6,9): Check Memory Using Absolute Address	242
10.3.14.	TM(6,6): Memory Dump Absolute address	242
10.3.15.	TM(6,10): Memory Check Report Absolute address.....	242
10.3.16.	TC(8,4): Perform Activity of Function.....	243
10.3.17.	TC(9,4): Enable Time Synchronization	245
10.3.18.	TC(9,5): Time Code	245
10.3.19.	TC(9,7): Enable Time Verification.....	245
10.3.20.	TM(9,9): Time Verification Report.....	245
10.3.21.	TC(14,1): Enable Generation of telemetry Packets	246
10.3.22.	TC(14,2): Disable Generation of telemetry Packets	246
10.3.23.	TC(14,3): Report Enabled Telemetry Packets	246
10.3.24.	TM(14,4): Report Enabled Telemetry Packets.....	247
10.3.25.	TC(17,1): Perform Connection Test.....	247
10.3.26.	TM(17,2): Link Connection Report.....	247
10.4.	TC RESPONSES	248
10.5.	TC CONDITIONS	252
11.	PLANCK SORPTION COOLER SYSTEM BUDGETS.....	253
11.1.	SIZE AND MASS BUDGET	253
11.2.	POWER BUDGET	254



A1	APPENDIX 1: SCS LOOKUP TABLE (LUT)	A-1
A1.1	LUT DESCRIPTION	A-1
A1.2	SCS NOM AND RED LUT FOR FLIGHT	A-11
A2	APPENDIX 2: SCS DEVICES (HEATERS AND SENSORS)	A-28
A2.1	DEVICES ID FOR TELECOMMANDING:	A-28
A2.2	LIST OF SENSORS	A-28
A2.3	LIST OF HEATERS	A-30
	APPENDIX 3 SCS MIB	A-31
A3	TELEMETRIES PART	A-31
A3.1	PACKETS – PID, PIC AND TPCF TABLES	A-31
A3.1.1	The PID table	A-31
A3.1.1.1	General description	A-31
A3.1.1.2	PID Fields for variable length packets	A-33
A3.1.1.3	PID Fields for packets sent periodically	A-34
A3.1.2	The PIC table	A-34
A3.1.3	The TPCF table	A-34
A3.2	PARAMETERS – PCF, PLF AND VPD TABLES	A-35
A3.2.1	The PCF table	A-35
A3.2.1.1	PCF_NAME Field	A-35
A3.2.1.2	PCF_UNIT Field	A-35
A3.2.1.3	PCF_PTC and PCF_PFC Fields	A-36
A3.2.1.4	PCF_WIDTH Field	A-36
A3.2.1.5	PCF_VALID and PCF_VALPAR Fields	A-36
A3.2.1.6	PCF_CATEG Field	A-37
A3.2.1.7	PCF_NATUR Field	A-37
A3.2.1.8	PCF_CURTX Field	A-37
A3.2.1.9	PCF_INTER Field	A-38
A3.2.2	The PLF table	A-39
A3.2.2.1	General description	A-39
A3.2.2.2	Specific cases	A-40
A3.2.3	The VPD table	A-43
A3.3	SYNTHETIC PARAMETERS	A-46
A3.3.1.1	Definition of a synthetic parameter	A-46
A3.3.1.2	Naming of SCE synthetic parameters	A-46
A3.3.1.3	SCE synthetic parameters description	A-46
A3.4	CALIBRATIONS – CAF, CAP, TXF, TXP, MCF AND CUR TABLES	A-52
A3.4.1	The CAF and CAP tables - Numerical calibrations	A-52
A3.4.2	The TXF and TXP tables- Textual calibration	A-54
A3.4.3	The MCF table - Polynomial calibrations	A-56
A3.4.4	The CUR table	A-56
A3.4.5	Curve identifiers	A-56
A3.5	MONITORING LIMITS – OCF AND OCP TABLES	A-57
A3.5.1	General description	A-57
A3.5.2	Monitoring limits for uncalibrated parameters	A-59
A3.5.3	Monitoring limits for textual calibrated parameters	A-59
A3.5.4	Monitoring limits for synthetic parameters	A-60
A3.5.5	Monitoring limits for numerical calibrated parameters	A-61
A3.6	DISPLAYS – DPF, DPC, GPF, GPC, SPF AND SPC TABLES	A-66



A3.6.1	Alphanumeric displays – DPF and DPC tables	A-66
A3.6.1.1	Housekeeping displays in boot mode.....	A-67
A3.6.1.2	Housekeeping displays in ASW mode.....	A-68
A3.6.1.2.1	ANDs for parameters which are not link to physical sensors.....	A-68
A3.6.1.2.2	ANDs for parameters which are link to physical sensors.....	A-70
A3.6.1.3	Diagnostic displays in boot mode.....	A-72
A3.6.1.4	Diagnostic displays in ASW mode.....	A-75
A3.6.1.5	Other displays.....	A-77
A3.6.1.5.1	AND for telemetries service 1	A-77
A3.6.1.5.2	AND for telemetries service 5	A-78
A3.6.1.5.3	AND for telemetries service 6 subtype 10.....	A-79
A3.6.1.5.4	AND for telemetries service 9 subtype 9.....	A-79
A3.6.2	Graphical displays – GPF and GPC tables	A-80
A3.6.3	Scrolling displays – SPF and SPC tables.....	A-81
A4	COMMANDS PART	A-83
A4.1	PACKET HEADERS – TCP, PCPC AND PCDF TABLES	A-83
A4.2	COMMANDS – CCF, CDF AND CPC TABLES	A-84
A4.2.1	The CCF table.....	A-84
A4.2.2	The CDF and CPC table.....	A-86
A4.2.2.1	CPC_PTC and CPC_PFC Fields	A-86
A4.2.2.2	Command parameter default values	A-87
A4.2.2.3	CDF_ELLEN and CDF_BIT fields	A-87
A4.2.2.4	CPC_CATEG, CPC_CCAREF and CPC_PAFREF fields	A-88
A4.2.2.5	CPC_PRFREF field.....	A-88
A4.2.2.6	Repeated Groups and the CDF_GRPsize field	A-88
A4.2.2.7	CDF_ELTYPE field.....	A-89
A4.3	THE PAF AND THE PAS TABLES	A-90
A4.4	THE PRF AND THE PRV TABLES.....	A-90
A4.5	SUMMARY OF EDITABLE PARAMETERS IN THE SCE SYSTEM.....	A-91
A4.5.1	Editable parameters of TC 8_4 - Set initial Heatup Bed Position	A-91
A4.5.2	Editable parameters of TC 8_4 - Set Bed State	A-91
A4.5.3	Editable parameters of TC 8_4 - Set Device State.....	A-91
A4.5.4	Editable parameters of TC 14_1 and TC 14_2.....	A-91
A4.5.5	Editable parameters of TC 6_2.....	A-92
A4.5.6	Editable parameters of TC 6_2.....	A-93
A4.5.7	Editable parameters of TC 6_5 and TC 6_9.....	A-93
A4.5.8	Editable parameters of TC 9_5 - Time Code.....	A-93
A4.6	PRE-TRANSMISSION VERIFICATION – THE PTV TABLE.....	A-94
A4.7	TC COMPLETION – THE CVS, CVE AND CVP TABLES	A-96
A4.7.1	The CVS table	A-96
A4.7.2	The CVP Table.....	A-97
A4.7.3	The CVE table	A-98
A5	LOOKUP TABLE PART	A-102
A5.1	GENERAL DESCRIPTION.....	A-102
A5.1.1	Introduction.....	A-102
A5.1.2	Principe of LUT programming.....	A-102
A5.1.3	Principe of LUT read back.....	A-103
A5.1.4	LUT segmentation	A-104
A5.1.5	The SC500530 ‘Get LUT Address’ command	A-104
A5.2	LUT PROGRAMMING.....	A-105



A5.3	LUT READ BACK.....	A-107
A5.3.1	LUT read back commands	A-107
A5.3.2	LUT read back telemetries	A-107
A5.4	LUT SEGMENTATION AND ASSOCIATED PARAMETERS	A-109



LIST of ACRONYMS

ABCL	As-Built Configuration List
ACK	Acknowledgement
ACMS	Attitude Control Management System
AD	Applicable Document
AIV	Assembly, Integration and Verification
ASI	Agenzia Spaziale Italiana (Italian Space Agency)
ASPI	Alcatel SPace Industry
ASW	Application SoftWare
AVM	Avionics Verification Model
AWG	ESA's Astronomical Working Group
BBM	(DPC software) Bread-Board Model
BEM	Back End Module (LFI)
BEU	Back End Unit (LFI)
BIN, bin	Binary
BOL	Begin of Life
CC	Change Control
CCB	Configuration Control Board
CCE	Central Check-out Equipment
CCS	Central Check-out System
CDMS	Command and Data Management Subsystem
CDMU	Central Data Management Unit
CFRP	Carbon Fiber Reinforced Plastic
CIDL	Configuration Item Data List
CoG	Centre of Gravity
CQM	Cryogenic Qualification Model
CRC	Cyclic Redundancy Check
CS	Conducted Susceptibility
CSL	Centre Spatial de Liege
CTE	Coefficient of thermal expansion
CTR	Central Time Reference
DAE	Data Acquisition Electronics (LFI)
DC	Direct Current
DDID	Data Distribution Interface Document
DDS	Data Distribution System
DEC, dec.	Decimal
DFE	Data Front End
DM	(DPC software) Development Model
DMS	Documentation Management System
DPC	Data Processing Centre
DPU	(Data (or Digital) processing Unit
DRS	Data Reduction Software
DS	Data Server
DTCP	Daily Telecommunication Period
ECR	Engineering Change Request
EE	End to End test
EEPROM	Electrically Erasable PROM
EGSE	Electrical Ground Support Equipment



EM	Engineering Model
EMC	Electro-Magnetic Compatibility
EMI	Electro-Magnetic Interference
EOL	End of Life
EPS	Electrical Power Subsystem
EQM	Engineering-Qualification Model
ESA	European Space Agency
ESD	Electro Static Discharge
ESOC	European Space Operations Centre
ESTEC	European Space Technology and Research Centre
FCS	Flight Control System
FCU	Focal Plane Control Unit (SPIRE)
FDIR	Failure Detection, Isolation and Recovery
FEM	Front End Module (LFI)
FEU	Front End Unit (LFI)
FID	Function Identifier
FM	Flight Model
FMECA	Failure-Modes, Effects and Criticality Analysis
FOP	Flight Operations Plan
FOV	Field Of View
FPA	Focal Plane Assembly
FPS	Focal Plane structure
FPU	Focal Plane Unit
FS	Flight Spare
FTS	File Transfer System
GS	Ground Segment
H/W	Hardware
HEX, hex.	Hexadecimal
HFI	High Frequency Instrument (Planck)
HK	House Keeping (data)
HPFTS	Herschel-Planck File Transfer System
HPLM	Herschel Payload Module
IAP	Institut d'AstroPhysique
IAS	Institut d'Astrophysique Spatiale
ICD	Interface Control Document
ICS	Instrument Commands Sequence
ICWG	Instrument Coordination Working Group
ID	Identifier
IDT	Instrument Development Team
IID	Instrument Interface Document
IID-B	Instrument Interface Document - part B
ILT	Instrument Level Test
IMT	Integrated Module Tests
IOM	Instrument Operations Manager
IOT	Instrument Operations Team
IRD	Interface Requirements Document
IST	Integrated System Test
ITT	Integration and Test Team
JPL	Jet Propulsion Laboratory
JT	Joule Thompson
kbps	kilobits per second
LCL	Latch Current Limiter
LEOP	Launch and Early Operations Phase



LFI	Low Frequency Instrument (Planck)
LGA	Low Gain Antenna
LL	Low Limit
LPSC	Laboratoire Physic Subatomic et Cosmologie
LSB	Least Significant Bit
Mbps	Megabits per second
MCC	Mission Control Centre
MGSE	Mechanical Ground Support Equipment
MIB	Mission Information Base (database)
MLI	Multilayer Insulation
MOC	Mission Operations Centre
Mol	Moment of Inertia
MOS	Margin Of Safety
MPS	Mission Planning System
MSB	Most Significant Bit
MTL	Mission Time Line
N/A, n.a.	Not Applicable
NaN	Not a Number
NCR	Non Conformance Report
NRT	Near-Real-Time
OATs	Osservatorio Astronomico di Trieste
OBCP	On-Board Control Procedure
OBSM	On-Board Software Maintenance
OD	Operational Day
OIRD	Operations Interface Requirements Document
OM	(DPC software) Operations Model
OOL	Out-of-Limits
PA	Product Assurance
PC	Pre-Cooler
PCDU	Power Control & Distribution Unit
PCS	Power Control Subsystem
PEC	Packet Error Control
PFM	Proto Flight Model
PGSSG	Planck Ground Segment System Group
PID	Parameter Identifier
PLFEU	Planck LFI Front End Unit (FEU)
PLM	Payload Module
PM	Project Manager
PPLM	Planck Payload Module
PR	Primary Reflector
PROM	Programmable Read Only Memory
PS	Project Scientist
PSO	Planck Science Office
PSS	Procedures, Specifications and Standards
PSVM	Planck Service Module
PV	Performance Verification
QA	Quality Assurance
QLA	Quick Look Analysis (software)
RAM	Random Access Memory
RD	Reference Document
RF	Radio Frequency
RFW	Request for Waiver
RLA	Register Load Address



ROM	Read Only Memory
RT	Real Time
RTA	Real-Time Analysis
RTU	Remote Terminal Unit
S/C	Spacecraft
S/W	Software
SAA	Solar Aspect Angle
SC	SpaceCraft
SCC	Sorption Cooler Compressor
SCCE	Sorption Cooler Cold End
SCE	Sorption Cooler Electronics
SCOE	Special Check-out Equipment
SCOE	Special Check Out Equipment
SCOS	Spacecraft Control and Operations System
SCP	Sorption Cooler Pipes
SCS	Sorption Cooler Subsystem (Planck)
SDE	Software Development Environment
SDU	Service Data Unit
SFT	Short Functional Test
SID	Structure Identifier
SLE	Standard Laboratory Equipment
SPACON	SPAcecraft CONtroller
SPR	Software Problem Report
SR	Secondary Reflector
SSMM	Solid State Mass Memory
SS	Stainless Steel
ST	Science Team
STM	Structural/Thermal Model
STMM	Simplified Thermal Model
SVM	SerVice Module
SVT	System Validation Test
TA	Telescope Assembly
TBC	To Be Confirmed
TBD	To Be Defined
TBS	To Be Specified
TBW	To Be Written
TC	TeleCommand
TCE	Telecommand Encoder
TCS	Thermal Control System
TID	Task Identifier
TM	Telemetry
TMM	Thermal Mathematical Model
TMP	Telemetry Processor
TMU	Thermo Mechanical Unit (Sorption cooler)
TOD	Time-Ordered Data
TOI	Time-Ordered Information
TQL	Telemetry Quick-Look
UM	User's Manual
URD	Users Requirements Document
UTC	Universal Time Coordinate(d)
VG	V-Groove radiator
WU	Warm Units



APPLICABLE & REFERENCED DOCUMENTS

Applicable Documents

Ref.	Doc. Ref. Nr.	Issue/Rev	Document Title
AD-01	PT-IID-A-04624	4.0	FIRST/PLANCK INSTRUMENT INTERFACE DOCUMENT – PART A
AD-02	PT-LFI-04142	2.1	FIRST/PLANCK INSTRUMENT INTERFACE DOCUMENT – PART B
AD-03	PL-LFI-PST-ID-002	3.1	Planck Sorption Cooler ICD
AD-04	ES518265	B1	TMU Specification Document
AD-05	PL-MA-CRS-0036	2.0	Planck Sorption Cooler Electronics User Manual
AD-06	UM-PSCBC-500075-LPSC	2/5	Planck Sorption Cooler Electronics OBSW User Manual
AD-07	TS-PSCBC-100010-LPSC	8/2	Planck Sorption Cooler Electronics OBSW TC and TM Structures
AD-08	PA-PSCB-100006-ISN	2/1	Planck Sorption Cooler Electronics FMECA

Referenced Documents

Ref.	Doc. Reference Nr	Issue/Rev	Document Title
RD-01	PL-LFI-PST-ID-002	3.1	Planck Sorption Cooler ICD
RD-02	PT-LFI-04142	2.1	FIRST/PLANCK INSTRUMENT INTERFACE DOCUMENT – PART B
RD-03	PL-MA-CRS-0036	2.0	Planck Sorption Cooler Electronics User Manual
RD-04	PA-PSCB-100006-ISN	2.0	Planck Sorption Cooler Electronics FMECA
RD-05	UM-PSCBC-500075-LPSC	2.0	Planck Sorption Cooler Electronics OBSW User Manual

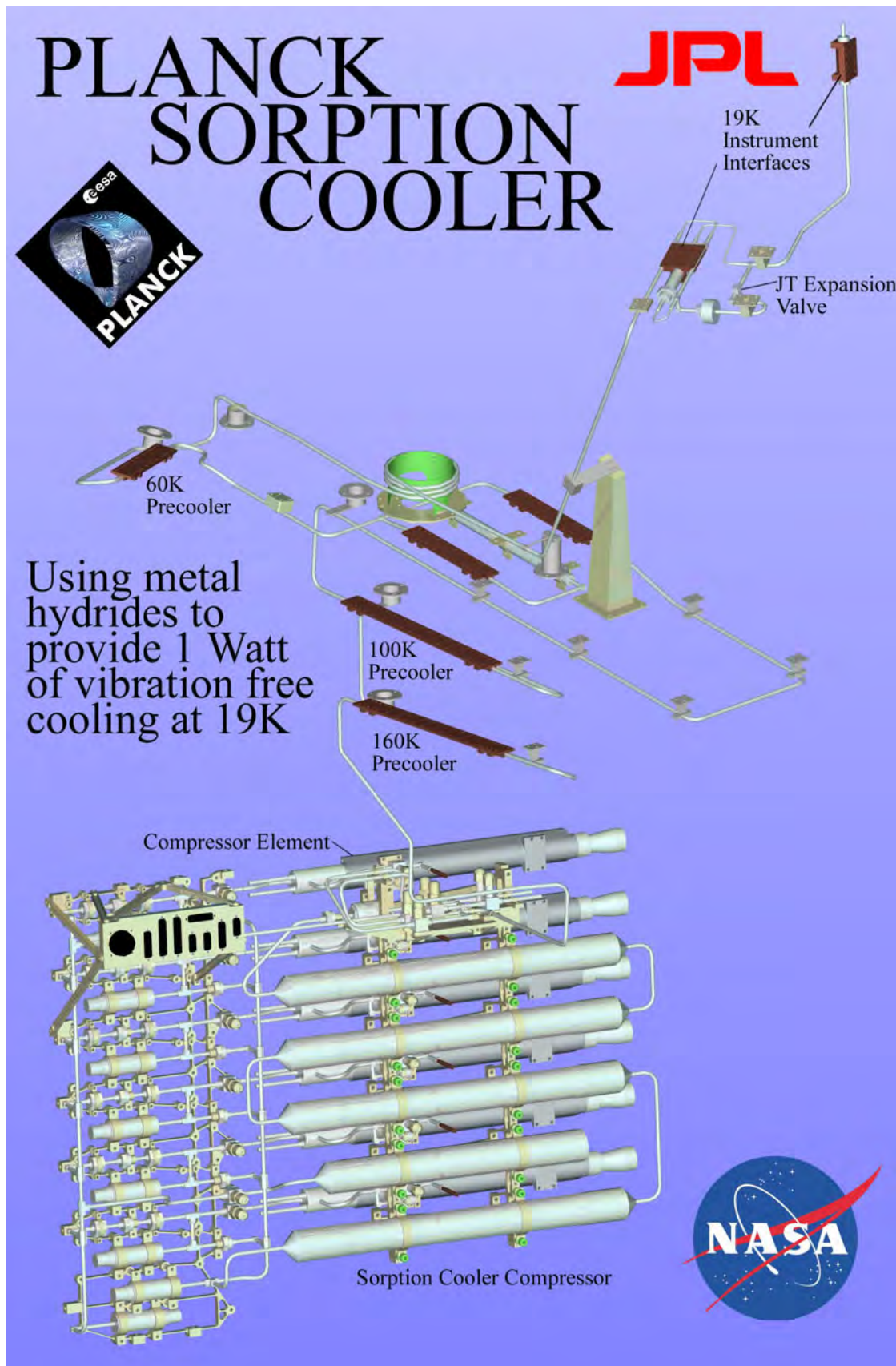



1. Planck SCS Description

1.1. *The Planck Sorption Cooler System*

The Planck Sorption Cooler System (SCS) is a closed-cycle continuous cryocooler designed to provide >1 Watt of heat lift at a temperature of <20K using isenthalpic expansion of hydrogen through a Joule-Thompson valve (J-T). Some of this heat lift will be provided to cool the Low-Frequency Instrument (LFI) onboard the Planck spacecraft. The remaining heat lift will be used as a pre-cooling stage for two further cryogenic refrigerators (He J-T cooler to 4K; Dilution cooler to 0.1K) that will in turn maintain the High-Frequency Instrument (HFI) at 100mK.

The sorption cooler performs a simple thermodynamic cycle based on hydrogen compression, gas pre-cooling by three passive radiators, further cooling due to the heat recovery by the cold low pressure gas stream, expansion through a J-T expansion valve and evaporation at the cold stage. A schematic of the Planck Sorption Cooler System (SCS) is shown in Fig. 1-1.

The Sorption Cooler System is composed of the Thermo-Mechanical Unit (TMU), the Sorption Cooler Electronics (SCE) and the internal harness. Configuration of these subsystems is described in Chapter 2. Their functional characteristics are explained in Chapter 3.

The TMU is the closed fluid circuit that, circulating H₂, produces the required cooling. It is composed by the Sorption Cooler Compressor (SCC) and the Piping and Cold End (PACE) that can be split into two subsections, the Piping (SCP) and the Cold End (SCCE): a schematic of the TMU is shown in Fig. 1-1. The TMU also includes all the sensors and heaters needed for control and monitoring.

The SCE is the hardware/software system that allows TMU operation, control and monitoring. It is the "interface" between the TMU and the Operator.

Two complete SC Systems (TMU + SCE, Nominal and Redundant) are present onboard the Spacecraft in order to provide full redundancy during the 18-month mission. For the purposes of this Manual they can be considered practically identical: the only differences are related to some external arrangements indicated in JPL drawings 10203010, 10203014, Alcatel Drawing PLAPIPS-0000 and specified in paragraphs 3.1.2, Physical Characteristics, and 3.1.3.1, Mechanical Interfaces, of the TMU Spec Document [ref. AD0].

All the information, procedures and operations described in this Manual apply equally to both Units unless specifically mentioned.

The SCC and PACE in each of the nominal and redundant coolers forms an all-welded, principally stainless steel assembly of fluid loop components which, with associated permanently installed wiring and adapter brackets, is handled and installed as a single, non-separable unit.

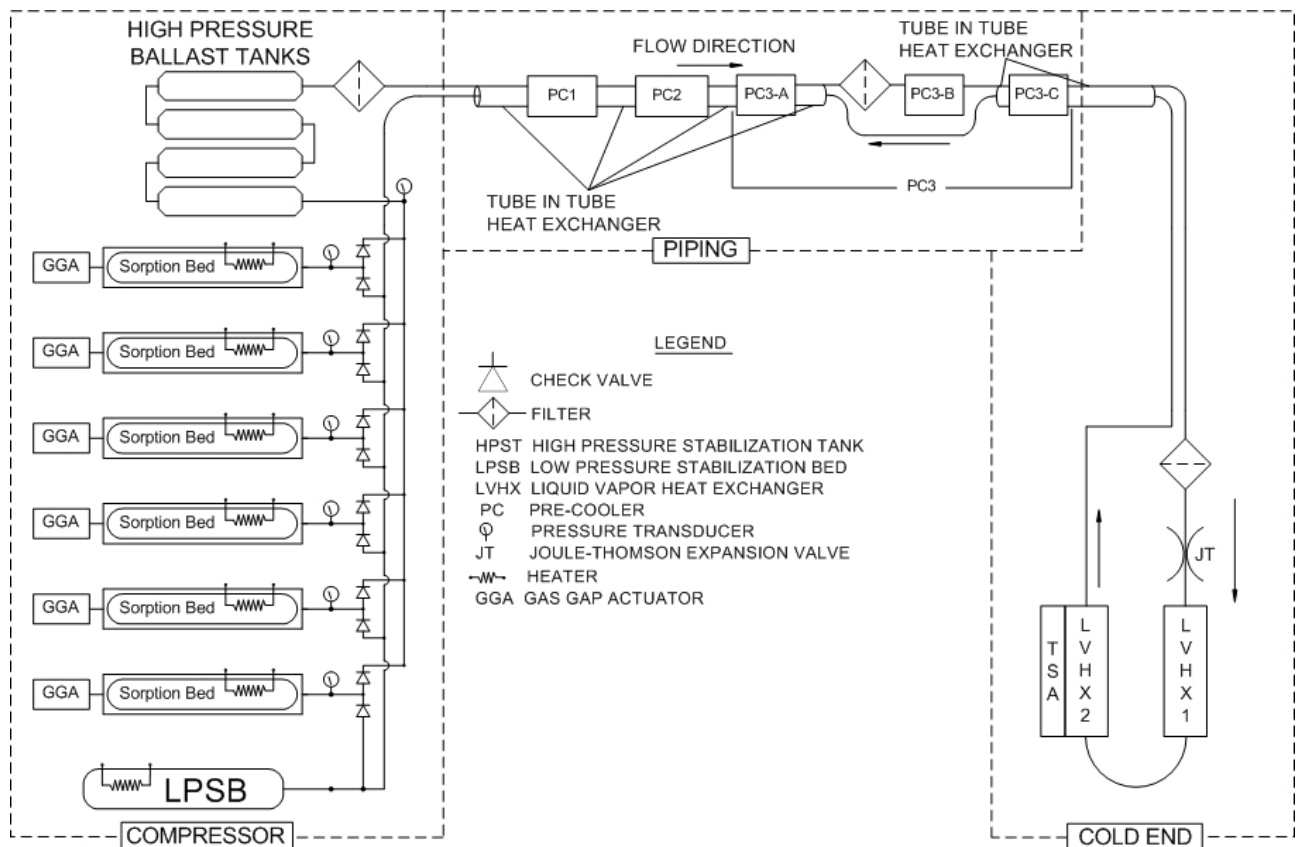

Figure 1-1 TMU schematic

The Sorption Cooler Compressor (SCC)

- Stores the H₂ gas
- Generates the high-pressure gas to be expanded in the Cold End
- Absorbs the returning low-pressure gas
- Stabilizes P fluctuations in both gas lines

The Sorption Cooler PACE

- Conveys hydrogen gas to and from the cold end
- Pre-cools the H₂ by tube-in-tube heat exchangers and thermal contact with passive radiators
- Expands the gas to form liquid
- Stores the liquid in reservoirs to provide a T reference for the Instruments
- Stabilizes by an active controller the T at the LFI I/F

The Sorption Cooler Electronics (SCE)

- Controls the TMU by
 - switching control for the sorption bed heaters
 - switching control to the heat switches
 - timing signals for the switching
 - controlling of power to the compressor elements in the “desorbing” state
 - controlling the T of the Temperature Stabilization Assembly (TSA) in the PACE.
- Detect abnormal situations and react



- Read temperature, voltage and intensity sensors from sorption cooler electronic.
- Receive commands from CDMU sent by users from ground
- Send housekeeping data to CDMU that will be transmitted to ground by telemetry.

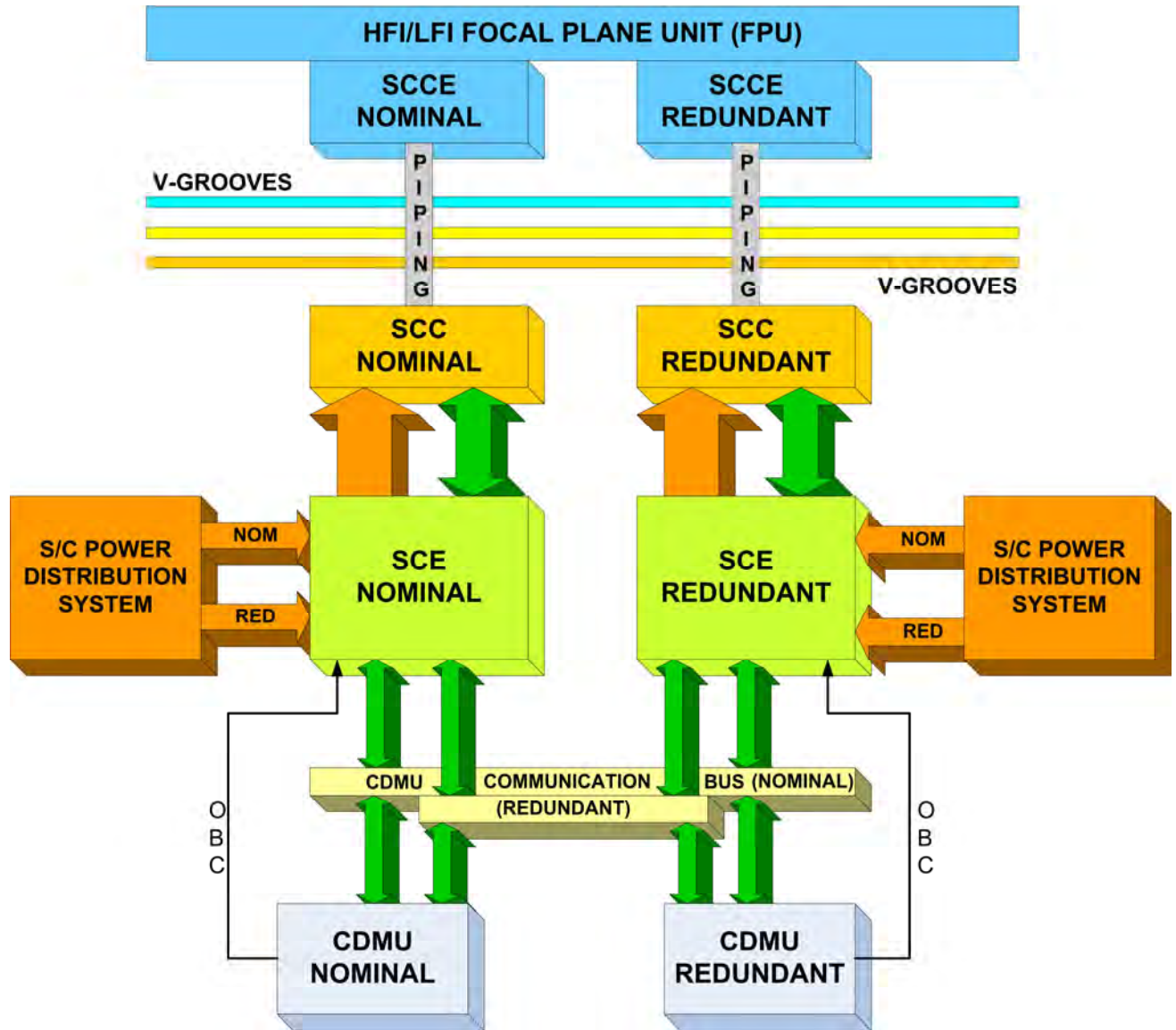

Figure 1-2 Planck SCS (TMU+SCE) Block Diagram

1.2. The Planck Sorption Cooler Principle of Operation

The operational concept of the system is relatively simple. Cooling power is function of the precooling stage (basically the third V-Groove) temperature and the mass flow rate across the J-T throttle valve. The cold end temperature is a function of the absorbing pressure in the hydride beds. The absorbing pressure is principally a function of the warm radiator temperature. The cooler is essentially “throttled” in a cycle frequency and input power/desorption temperature to provide the required cooling.



The principle of operation of the sorption compressor (Figure 1-3) is based on the properties of a sorption material which can absorb large amounts of hydrogen at relatively low pressures and low temperature, and which can desorb to produce high-pressure hydrogen when heated in a limited volume. The sorbent bed is periodically cycled between heating and cooling cycles, producing high-pressure gas intermittently. In order not to lose excessive amounts of heat during the heating cycle, a heat switch is provided to alternately isolate the sorbent bed from the radiator during the heating cycle, and to connect it to the radiator thermally during the cooling cycle.

As a sorption compressor element (i.e. sorbent bed) is taken through four steps in a cycle (heatup, desorption, cooldown, absorption), it will intake low pressure hydrogen and output high-pressure hydrogen on an intermittent basis. If the high-pressure hydrogen is pre-cooled with radiators to below the inversion temperature and then expanded through a Joule-Thomson expansion orifice (J-T) the high-pressure gas will partially liquefy, producing liquid refrigerant at low pressure for sensor systems. Heat evaporates liquid hydrogen, and the low-pressure gaseous hydrogen is re-circulated back to the sorbent for compression.

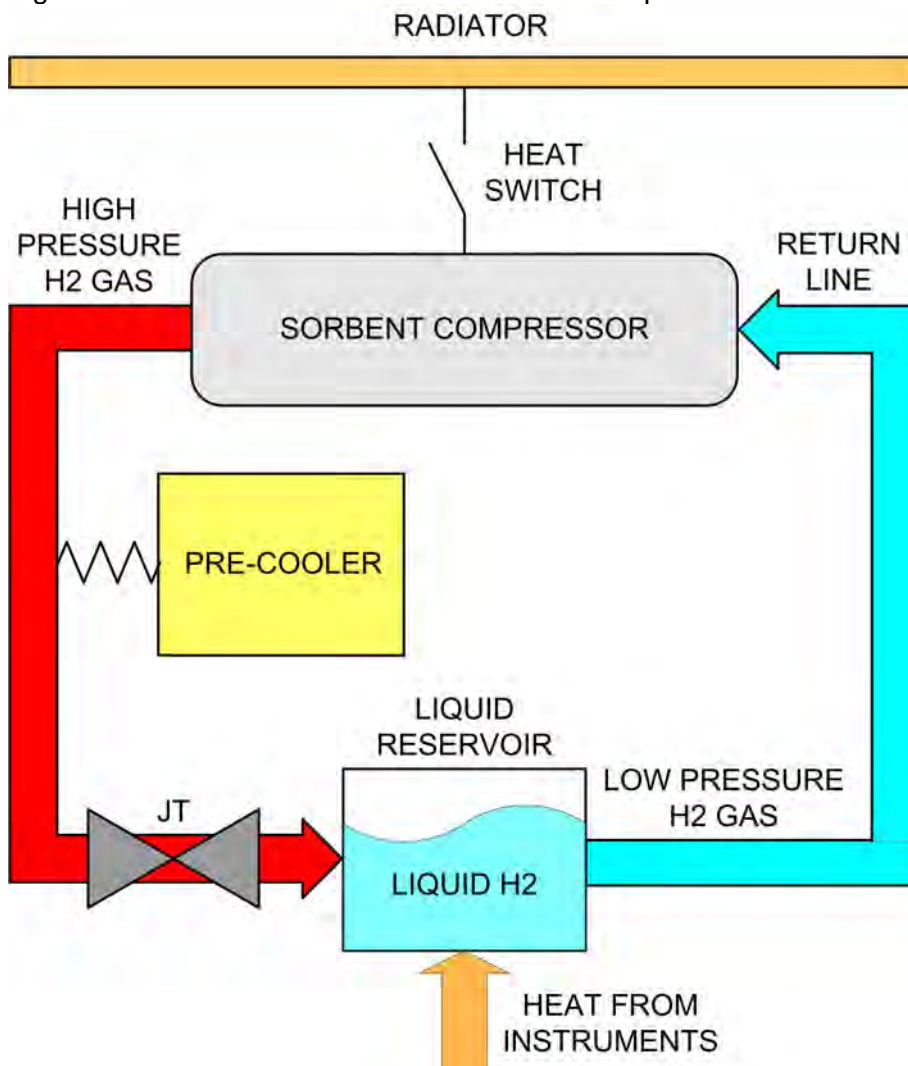

Figure 1-3 Sorption Cooler principle of operation

In order to produce a continuous stream of liquid refrigerant, it is possible to employ several such sorption beds and stagger their phases (like a mechanical gas engine) so that at any given



time, one is desorbing high pressure gas while the others are either heating, cooling, or re-absorbing low pressure gas. For this reason, the Planck compressor assembly shown in Figure 1.2 is composed of six compressor elements, each connected to both the high pressure and low pressure sides of the plumbing system through check valves, which allow gas flow in a single direction only. The check valves are indicated on the schematic (Figure 1-4) as single arrows, which indicate the direction of gas flow through them.

The high pressure refrigerant then travels from the compressor through a series of heat exchangers and passive radiators, which provide pre-cooling to a temperature below the refrigerant inversion point. Besides the six compressor elements and their check valves, the compressor assembly is also comprised of the high-pressure stabilization tanks and the low pressure stabilization bed. The compressor assembly mounts directly onto the heat rejection radiator.

The pre-cooled gas flow is then expanded through a Joule Thomson (JT) flow restriction valve and the liquid produced is collected in the Liquid Reservoir where it is utilized to provide the required cooling. The instruments heat load partially evaporates the LH₂ that is recovered by the compressor through the low pressure line in order to be re-compressed again in a continuous cycle.

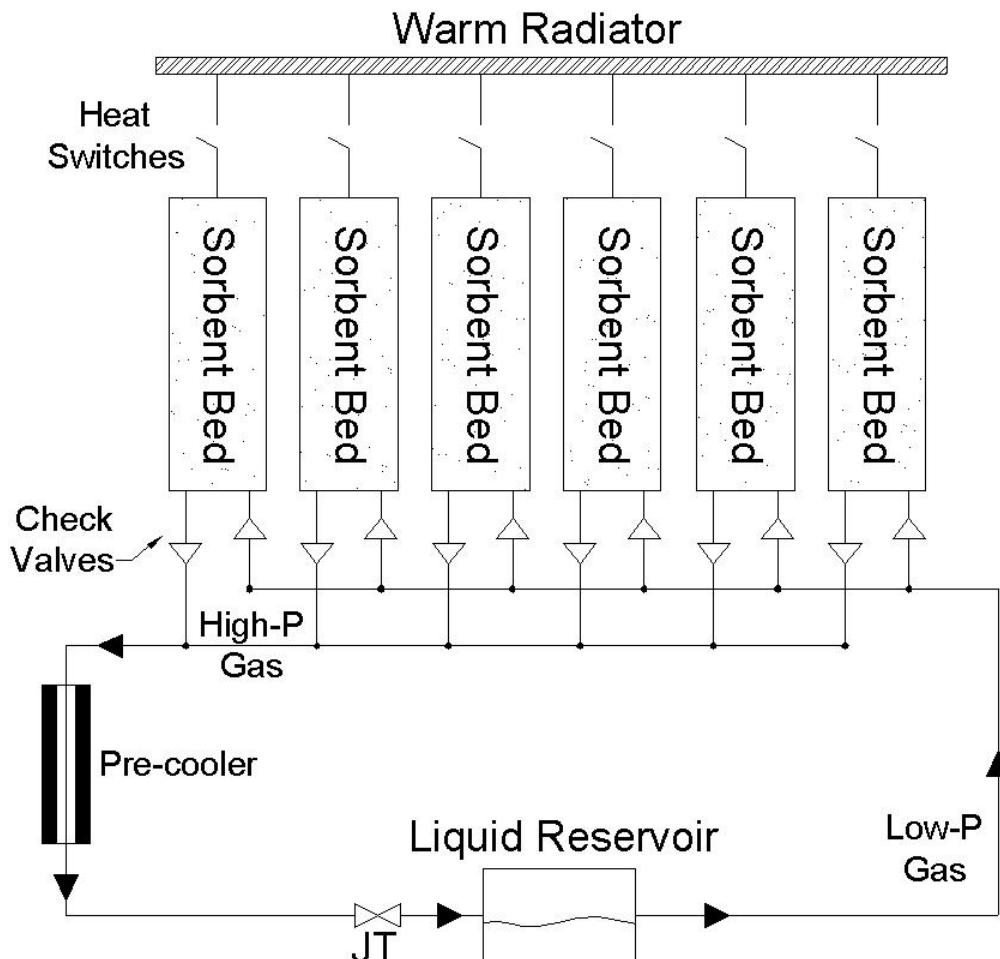

Figure 1-4 Planck Sorption Cooler Concept Schematic



1.3. SCS Thermo-Mechanical Unit (TMU)

The Planck TMU is a closed fluid loop with heaters, sensors and wiring (Figure 1-1) and is powered and controlled in flight by the Sorption Cooler Electronics.

The TMU can be divided into two major subsystems: the Sorption Cooler Compressor (SCC) and the Piping Assembly and Cold End (PACE). The first is responsible for compressing and recovering the H₂ gas circulated while maintaining in the Low Pressure return line the vapor pressure needed to meet the cooler requirements. The PACE function is to cool and liquefy the high pressure gas and collect the liquid in order to provide the required cooling.

Hydrogen is pressurized and circulated about the TMU fluid circuit by alternately heating and cooling the six sorbent beds one after another, causing them to release and absorb hydrogen gas by reversible chemical action. Cycling is accomplished by turning on and off at appropriate times heaters embedded in the compressor elements and controlled by Sorption Cooler Electronics solid-state relays. The check valves direct the released hydrogen: they ensure that when a sorbent bed being cooled reaches a pressure about 1-2 psi less than that of the low-pressure manifold, low-pressure gas will flow into the sorbent bed. Similarly, a sorbent bed in the heating mode will drive high-pressure gas into the high-pressure manifold when its pressure exceeds that of the manifold by ~1-2 psi.

To help steady the hydrogen flow and mitigate pressure fluctuations, a ballast volume (HPST) is included in the high-pressure manifold at the outlet of the hydride containers. The flow rate of hydrogen through the J-T orifice is controlled by the size of the orifice itself and the pressure difference across it. The high-pressure ballast tank assures that pressure fluctuations are very small, and therefore flow through the J-T is essentially constant. Similarly, a high capacity buffer hydride bed (Low Pressure Stabilization/Storage Bed or LPSB) is included on the inlet side of the CE's in the low-pressure manifold to minimize low-pressure fluctuations.

The high pressure gas leaving the Compressor, enters the PACE (Piping Assembly and Cold End) and flows through heat exchanger piping (HX1-HX4) for heat recovery by the cold low pressure returning gas stream. The H₂ is also pre-cooled through successively colder pre-cooler heat sinks (PC1-PC3, respectively at about 170 K, 100 K and 50 K) on each spacecraft thermal shield (or V-groove).

The gas flow is then expanded through a JT flow restriction valve and the liquid hydrogen is collected in two reservoirs (LVHX1 and LVHX2) where the liquid droplets evaporation provides the cooling power to the instruments. A third liquid reservoir (LVHX3) collects any excess liquid hydrogen. Hydrogen gas then passes back through the heat exchanger piping (HX4-HX1) in the low pressure line, which return it to the hydride containers where it is re-absorbed.

Filters (Fn) are positioned about the fluid loop to remove particulate and chemical contaminants. Pressure transducers (Pn) are installed in the fluid loop to complement the externally mounted temperature sensors (Tn) for system monitoring and control. Lead wires from the sensors and the various heaters are collected into several cable bundles that terminate in connectors mounted on the Compressor and Cold End, for access by outside electronics.

1.4. The Sorption Cooler Electronics (SCE) Description

The SCE (Nominal or Redundant) is the electronics unit that controls and monitors the SCS TMU (Nominal and Redundant). Each model is associated to the corresponding TMU and can



operate that TMU only. Only one SCE unit, therefore one TMU, can be powered and operated at a time.

The selection of the working SCE is made by the S/C by selecting the appropriate 28 V lines. The Figure 1-2 shows the interface relationships between the SCE and the other parts of the SCS, together with the top-level redundancy concept of the SCS itself.

The **purpose** of the SCE is to:

- ▶ Drive the sorption cooler by
 - switching control for the sorption bed heaters
 - switching control to the heat switches
 - timing signals for the switching
 - controlling of power to the compressor elements in the “desorbing” state
 - controlling the T (PID) of the Temperature Stabilization Assembly (TSA) in the SCCE.
- ▶ Detect abnormal situations and react if a problem is detected in order to ensure the sorption cooler and its environment health. This is done by reading temperature and pressure sensors values from the sorption cooler.
- ▶ Read temperature, voltage and intensity sensors from sorption cooler electronic.
- ▶ Receive commands from CDMU sent by users from ground
- ▶ Send housekeeping data to CDMU that will be transmitted to ground by telemetry.

The control of the SCS is performed through the cooler sensors and heaters, listed in Chapter 2.



2. Planck Sorption Cooler System Configuration

2.1. Planck SCS Hierarchical Configuration

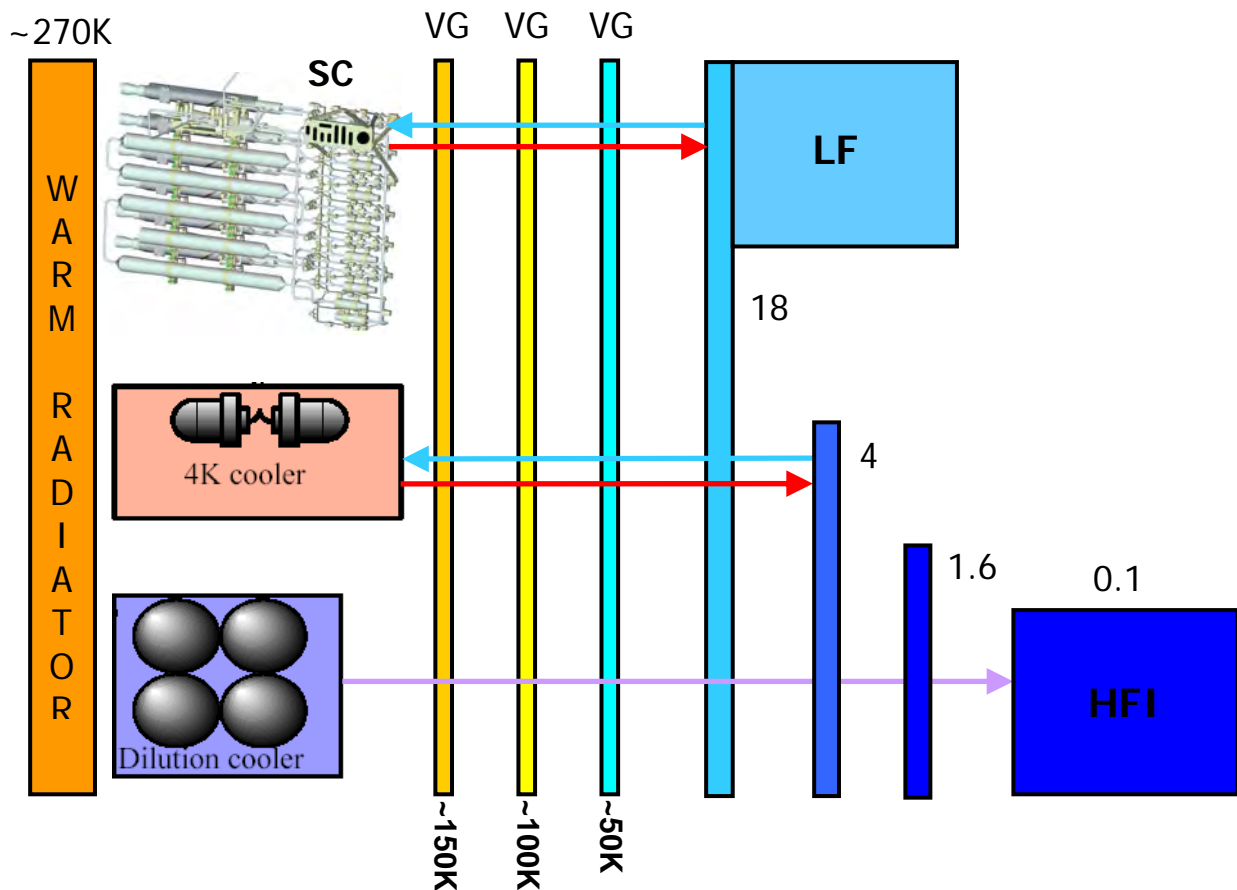

Figure 2-1 Planck cryogenic chain

The SCS is the first active cooling stage of the Planck cryogenic chain. Two identical coolers (one Nominal and one Redundant) exploit the passive cooling provided by three radiators (V-Groove 1, 2 and 3) in order to liquefy and store the hydrogen used as a temperature reference for the instruments. The first Liquid Vapour Heat Exchanger (LVHX1) provides a precooling stage for the HFI 4K JT cooler; the second liquid reservoir (LVHX2) is used to cool the LFI down to the operative temperature.

2.2. SCS Thermo-Mechanical Unit (TMU) Configuration

The Planck TMU is a closed fluid loop with heaters, sensors and wiring (Figure 2-2) and is powered and controlled in flight by the Sorption Cooler Electronics (see Par. 1.3). The TMU can be divided into two major subsystems: the Sorption Cooler Compressor (SCC) and the Piping Assembly and Cold End (PACE). The first is responsible for compressing and recovering the H₂ gas circulated while maintaining in the Low Pressure return line the vapor



pressure needed to meet the cooler requirements. The PACE function is to cool and liquefy the high pressure gas and collect the liquid in order to provide the required cooling.

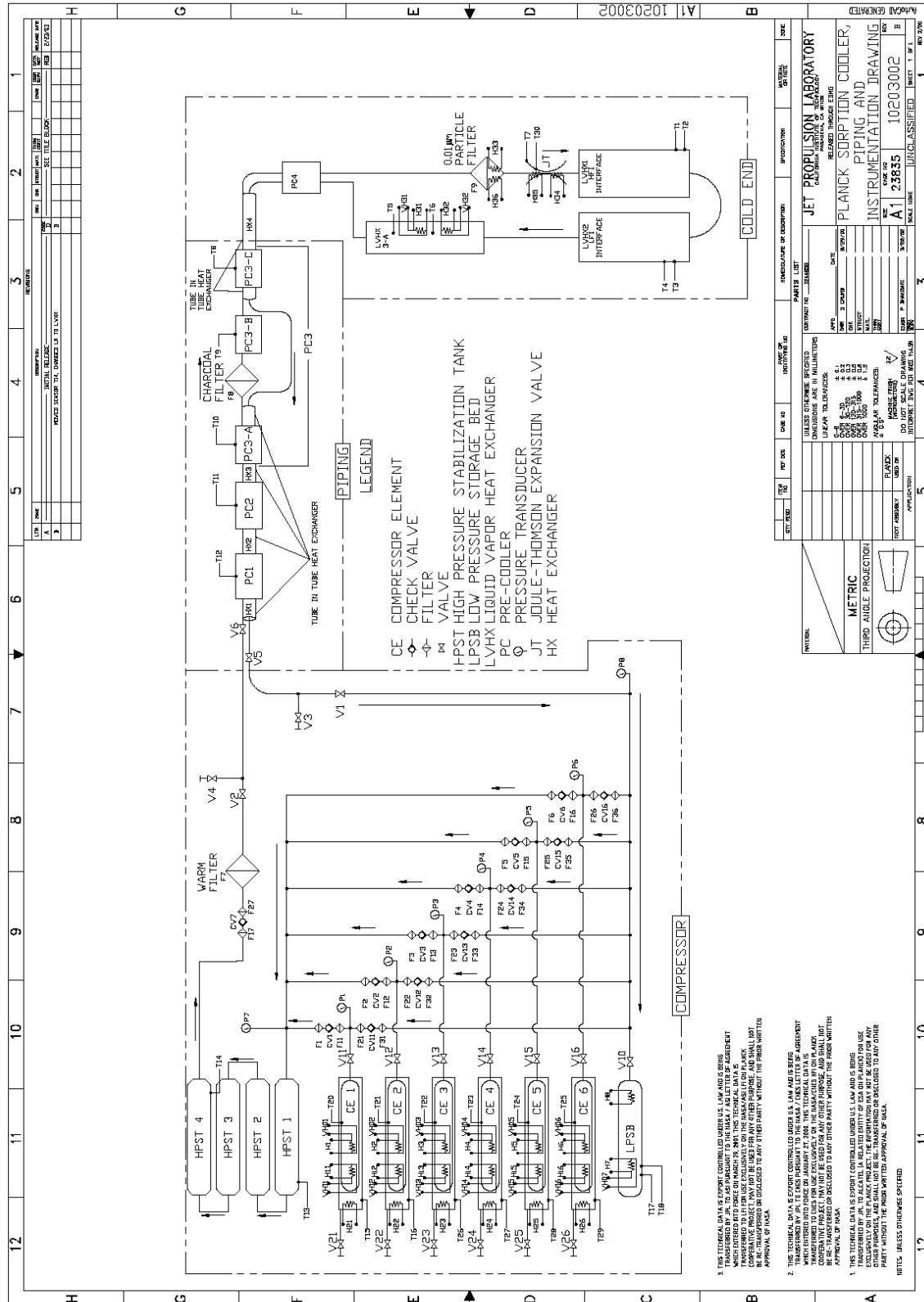

Figure 2-2 TMU detailed schematic including components, heaters, sensors



2.2.1. TMU Mechanical Configuration

In summary, the TMU comprises of the following subassemblies, components and parts (see Figure 2-2): the Sorption Cooler Compressor and the Piping and Cold End.

Major segments of the TMU are identified according to the thermal regime they occupy:

- The SCC at 270 K is the TMU segment that interfaces with the S/C active radiator panel;
- The SCP at 270-50 K is the TMU segment that interfaces with the S/C passive radiators at Pre-Coolers 1-3 (PC1, PC2, and PC3); and
- The SCCE at 22.5-19 K is the TMU segment that interfaces with the payload instrument surfaces at Liquid Reservoirs 2 and 1 (LVHX2+TSA, LVHX1).

2.2.1.1. Sorption Cooler Compressor (SCC) assembly

The “engine” of the SCS TMU is the Compressor (SCC): it is composed of six identical compressor elements (CE1-CE6, or sorbent beds, Figure 2-2) each filled with metal hydride ($\text{LaNi}_{4.78}\text{Sn}_{0.22}$) powder and provided with independent heating and cooling. Heating of the sorbent is accomplished by electrical resistance heaters while the cooling is achieved by thermally connecting the compressor element to a radiator (Warm Radiator), sized to reject the cooler input power at $270\text{ K} \pm 10\text{ K}$. Heat switching is accomplished by use of a gas gap surrounding the sorption bed that can alternately be filled with thermally conducting hydrogen gas, or evacuated to thermally insulate the gap.

This task is performed by Gas Gap Actuators (GGA) that, using a small amount of a low-pressure hydride sorbent (ZiNi), can be heated or cooled to increase or decrease the hydrogen pressure in the gap.

Hydrogen is pressurized and circulated about the TMU fluid circuit by alternately heating and cooling the six sorbent beds one after another, causing them to release and absorb hydrogen gas by reversible chemical action. Cycling is accomplished by turning on and off at appropriate times heaters embedded in the compressor elements and controlled by Sorption Cooler Electronics solid-state relays. The Check Valves (CV) direct the released hydrogen: they ensure that when a sorbent bed being cooled reaches a pressure about 1-2 psi less than that of the low-pressure manifold, low-pressure gas will flow into the sorbent bed. Similarly, a sorbent bed in the heating mode will drive high-pressure gas into the high-pressure manifold when its pressure exceeds that of the manifold by ~1-2 psi.

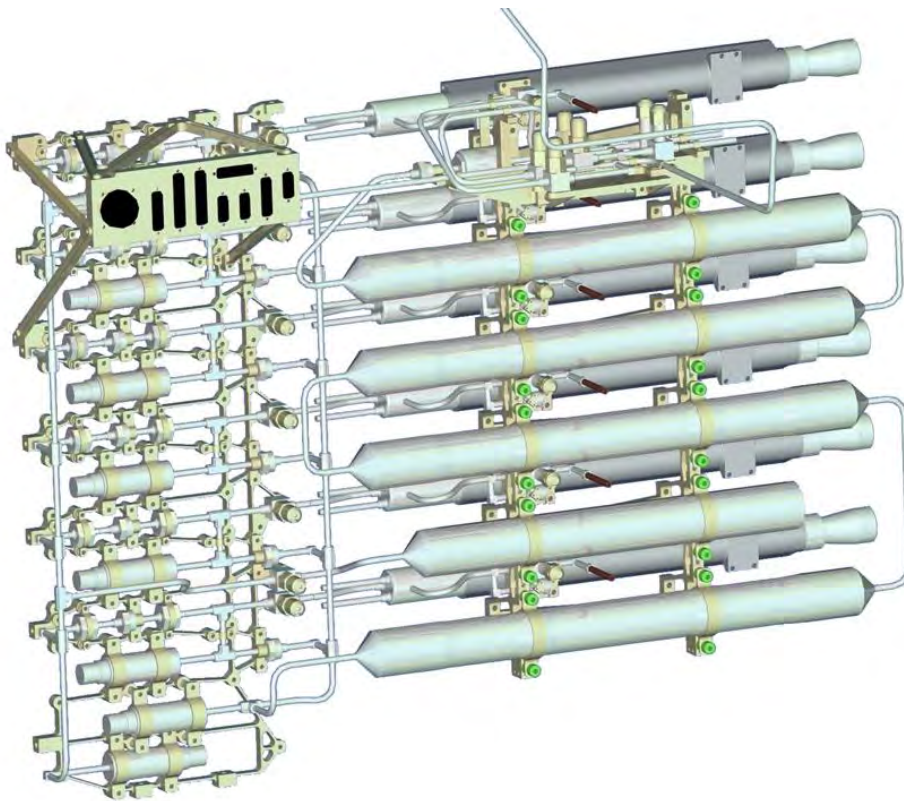

Figure 2-3 3D view of the SCS Compressor Assembly

If it were possible to produce a uniform flow of high-pressure gas within a single time cycle then, except for minor discontinuities when switching from compressor to compressor, the production rate of high-pressure hydrogen would be constant in time. In fact, the rate of desorption cannot be maintained exactly constant during a single time cycle. To help steady the hydrogen flow and mitigate pressure fluctuations, a ballast volume (HPST) is included in the high-pressure manifold at the outlet of the hydride containers. The flow rate of hydrogen through the J-T orifice is controlled by the size of the orifice itself and the pressure difference across it. The high-pressure ballast tank assures that pressure fluctuations are very small, and therefore flow through the J-T is essentially constant. Similarly, a high capacity buffer hydride bed (Low Pressure Stabilization/Storage Bed or LPSB) is included on the inlet side of the CE's in the low-pressure manifold to minimize low-pressure fluctuations.

The SCC is composed of (Figure 2-2):

- 1.1 Compressor Element (CE), 6 required
 - a) Hydride
 - b) Inner tube assembly
 - c) Outer tube assembly
 - d) Manifold assembly
 - e) Gas gap actuator assembly
- 1.2 Low Pressure Storage Bed (LPSB),
- 1.3 High Pressure Stabilization Tank (HPST), 4 required,
- 1.4 Manual Valves (Vn),



- 1.5 Filters (Fn),
- 1.6 Pressure Transducers (Pn),
- 1.7 Temperature Transducers (Tn),
- 1.8 Check Valves (CVn), and
- 1.9 Cable harness W002-W008

2.2.1.2. Piping Assembly and Cold End (PACE)

The PACE is a portion of a closed fluid loop with attached heaters, sensors, and wiring, as shown in Figure 1. Hydrogen is circulated about the PACE fluid loop by the SCC via heat exchanger piping (CFHX1-CFHX4), through successively colder pre-coolers heat exchangers (PC1, PC2, PC3A, PC3B, PC3C) and a Joule-Thomson expansion valve (JT). The resulting cold hydrogen liquid exchanges heat with the instruments via the Liquid-Vapor Heat Exchangers (LVHX1 and LVHX2). Another Liquid-Vapor Heat Exchanger, LVHX3, is available to evaporate excess liquid before the hydrogen gas passes back through the heat exchanger piping to the SCC.

Filters (Fn) are positioned about the fluid loop to remove particulate and chemical contaminants. Wires from the sensors and heaters are collected into cable bundles which terminate in connectors mounted on the SCC and SCP, for access by the Sorption Cooler electronics.

Major segments of the PACE are identified according to the thermal regime they occupy: The SCP at 270—20 K is the TMU segment which is attached to the spacecraft by means of mechanical restraints which support the piping against launch loads, and which rejects heat to the spacecraft passive radiators at Pre-Cooler Heat Exchangers PC1, PC2, PC3A, PC3B, PC3C. The SCP also contains a charcoal filter, thermometers, and associated cabling; The SCCE at 22.5-18 K is the TMU segment which removes heat from the instruments through the Liquid-Vapor Heat Exchangers LVHX1 and LVHX2. The SCCE also contains mechanical supports, thermometers, heaters, and associated cabling.

Figure 2-4 depicts the piping assembly (pre-coolers and heat exchangers). The pre-coolers conductively attach to radiators and are separated by tube-in-tube counter flow (CFHX) heat exchangers which consist of annular tubes with the incoming gas stream on the OD, and the outgoing gas stream on the ID.

Figure 2-5 depicts the cold end of the cooler, including two LVHX's (the low vapor heat exchangers) through which heat from the two instruments (HFI and LFI) are absorbed, a particle filter (contamination of the hydride with particulates would prove disastrous), a Joule Thompson (J-T) throttle valve, and several sections of CFHX's. The Temperature Stabilization Assembly (TSA) is between LVHX2 and the LFI interface. The TSA contains redundant heater/thermometer pairs connected to a closed loop electronic controller. The PACE of the two SCS Flight Models (Nominal and Redundant) are functionally identical, they differ only in the geometrical configuration.

The Type I [-Y] TMU is depicted on JPL drawings 10203010, 10203013, and Alcatel drawing PLAPIPS-0000.

The Type II [+Y] TMU is depicted on JPL drawings 10203010, 10203013, and Alcatel drawing PLAPIPS-0000.



The PACE can be divided in two major subsections: the Sorption Cooler Pipes (SCP) and the Sorption Cooler Cold End (SCCE).

The pipes (SCP), shown in Figure 2-4, connects the SCCE and the Sorption Cooler Compressor (SCC). The SCP are stainless steel tubes of OD 6.35 mm and 3.18 mm, about 9.5 m long.

The length of the heat exchanger sections between the Planck thermal stages are foreseen as indicated below:

Heat exchanger section	Length	Tolerance
300 to 160 K	1.5 m	± 10 cm
160 to 100 K	1.5 m	± 10 cm
100 to 50 K	3.0 m	± 10 cm
50 to 20 K	3.5 m	± 10 cm

The heat exchangers are pre-cooled at each thermal shield. In addition, a charcoal filter is located between the two pre-cooling heat exchangers at ~ 50 K.

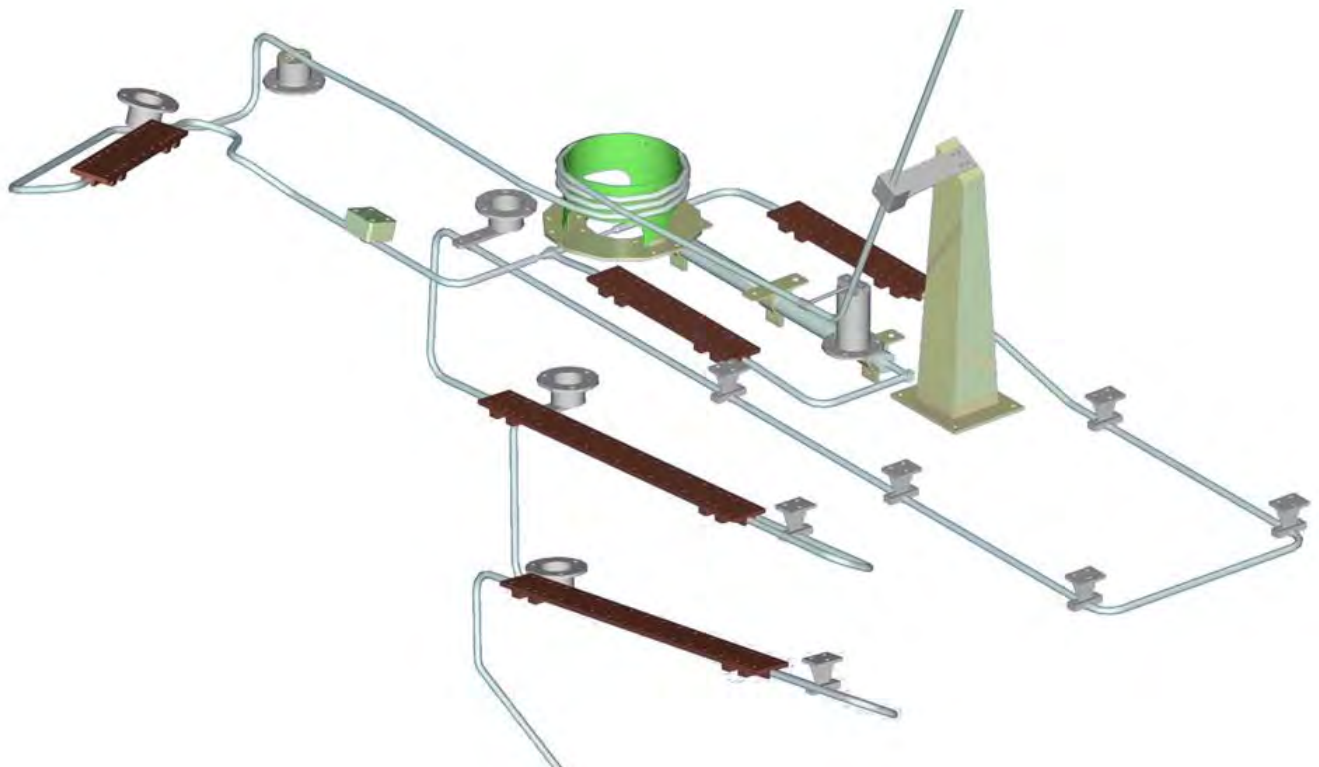

Figure 2-4 Cooler Piping from Compressor to Cold End

The Sorption Cooler Cold End (SCCE) is mounted on the LFI/HFI FPU and contains a contamination filter, a porous plug flow restrictor (the J-T expander), three liquid reservoirs and a temperature stabilization stage. Each cooler cold end consists of six components with interconnecting tubing. These can be mounted with a fair degree of flexibility. The figure below illustrates these elements and their general location.

A 3D view c of the Planck SCCE is shown in Figure 2-5.



Figure 2-5 Sorption Cooler Cold End

In detail the PACE (see Figure 2-2) is composed by:

The PACE comprises the following subassemblies, components and parts, see Figure 2-2.

1. Sorption Cooler Piping (SCP) assembly
 - a. Pre-Cooler Heat Exchangers (PC1, PC2, PC3A, PC3B, PC3C),
 - b. Counter-Flow Heat Exchangers (CFHX1, CFHX2, CFHX3, CFHX4),
 - c. Charcoal Filters (F8),
 - d. Mechanical Restraints,
 - e. Temperature Transducers (Tn), and
 - f. Cable harness W001.

2. Sorption Cooler Cold End (SCCE) assembly
 - a. Liquid-Vapor Heat Exchangers (LVHX1, LVHX2, LVHX3),
 - b. Joule-Thomson expansion valve (JT),
 - c. Mechanical Restraints,
 - d. Heaters (Hn),
 - e. Temperature Transducers (Tn), and
 - f. Cable harnesses W021, W022.



2.2.1.3. TMU Heaters and Sensors

Monitoring and control of the SCS is performed through the cooler sensors and heaters, listed in the following tables.

Planck Sorption Cooler Heaters (see also Figure 2-2)

Ref. ID	Description	R (Ω +3 -5%)	Power Range Required ⁸ (W) @ Nominal Voltage delivered to TMU				Resolution (W)
			12V	26V	@27.5 V	@31 V	
H1-H6	CE1-CE6 Heatup, Basic	5.2	-	130	146	-	NA
H11-H16 ⁽¹⁾	CE1-CE6 Heatup, Variable	5.55	-	≤43 to 117	≤27 to 102	-	0.1
H1-H6	CE1-CE6 Desorb, Basic	5.2	-	130	146	-	NA
H11-H16 ⁽¹⁾	CE1-CE6 Desorb, Variable	5.55	-	≤17 to 91	≤1.5 to 75.5	-	0.1
H21-H26	CE1-CE6 Gas Gap Act.	18.8 - 21.6	7	-	-	-	NA
H7 ⁽²⁾	LPSB, Variable	32.35	0 to 5	-	-	-	0.1
H8 ⁽³⁾	LPSB, Startup	19.65	-	36	40	-	NA
H31, H32 ^(3,6)	TSA, Variab., N&R	480 ⁽⁷⁾	-	-	-	0 to 2	0.01
H33, H36 ^(3,6)	F9 Defrost, N&R	170 ⁽⁷⁾	-	4	4	-	NA
H34, H35 ^(3,6)	JT, Defrost, N&R	170 ⁽⁷⁾	-	4	4	-	NA

- Notes:**
1. Power periodically adjusted upward as hydride ages.
 2. Power periodically adjusted downward as hydride ages.
 3. Activated only on specific command.
 4. Closed loop temperature control.
 5. Component acronyms used in this table are identified in Figure 2-2.
 6. H31 – H34 heater resistances are total resistances including associated wiring.
 7. Resistance tolerance for H31 – H34 is +/- 10%
 8. The above heater power ranges show the capability required of the heaters to allow for as much as 520 W of power input to the TMU system. The actual heater power consumption will be less than equal to the values above based on max. total power insertion into the TMU.

The SCS status, performance and behavior is monitored by a set of T and P sensors, listed in table (see also APPENDIX 2)



Planck Sorption Cooler Sensors (see also Figure 2-2)

T Sensors

Item	Location	Nominal (K)	Resolution requested for the specified range				Type
			Range I (K)	Resolution (K)	Range II (K)	Resolution (K)	
T1	LR1	18	16-25	0.010	20-80	1	CERNOX
T2	LR1	18	16-25	0.010	20-80	1	CERNOX
T3	LR2	20	16-25	0.010	20-80	1	CERNOX
T4	LR2	20	16-25	0.010	20-80	1	CERNOX
T5	LR3	20	16-24	0.004			CERNOX
T6	LR3	20	16-24	0.004			CERNOX
T7	JT	20	16-25	0.010	20-150	1	CERNOX
T8	PC3C	55	40-80	0.1	80-330	2	CERNOX
T9	PC3B	70	40-80	0.1	80-330	2	CERNOX
T10	PC3A	80	40-80	0.1	80-330	2	CERNOX
T11	PC2	100	80-150	0.1	150-330	2	CERNOX
T12	PC1	160	140-190	0.1	190-330	2	CERNOX
T13	HPST1	300	220-320	0.040			PRT
T14	HPST2	300	220-320	0.040			PRT
T15	Shell CE1	270	220-350	0.040			PRT
T16	Shell CE2	270	220-350	0.040			PRT
T17	LPSB	300	220-320	0.040			PRT
T18	LPSB	300	220-320	0.040			PRT
T19							
T20	CE1	40	0 - 275	0.3	275-425	1	KTC
T21	CE2	40	0 - 275	0.3	275-425	1	KTC
T22	CE3	40	0 - 275	0.3	275-425	1	KTC
T23	CE4	40	0 - 275	0.3	275-425	1	KTC
T24	CE5	40	0 - 275	0.3	275-425	1	KTC
T25	CE6	40	0 - 275	0.3	275-425	1	KTC
T26	Shell CE3	270	220-350	0.040			PRT
T27	Shell CE4	270	220-350	0.040			PRT
T28	Shell CE5	270	220-350	0.040			PRT
T29	Shell CE6	270	220-350	0.040			PRT
T30	JT	20	16-25	0.010	20-150	1	CERNOX

- Notes:**
1. Component acronyms used in this table are identified in Figure 2-2.
 2. PRT=Platinum Resistance Thermometer;
 KTC=Type K Thermocouple,
 CERNOX=LakeShore CX-1070/equiv.
 3. T20-T25 K thermocouples with reference junctions. Their measurements are the difference between the temperatures at the two junctions.



P Sensors

Name	Location	Nominal (bar)	Range (bar)	Resolution (bar)	Resolution (mV)	Accuracy (bar)	Input (Vdc)	Return (Vdc)
P1	CE1	50	0-67	0.07	5	0.3 FSR	28	0-5
P2	CE2	50	0-67	0.07	5	0.3 FSR	28	0-5
P3	CE3	50	0-67	0.07	5	0.3 FSR	28	0-5
P4	CE4	50	0-67	0.07	5	0.3 FSR	28	0-5
P5	CE5	50	0-67	0.07	5	0.3 FSR	28	0-5
P6	CE6	50	0-67	0.07	5	0.3 FSR	28	0-5
P7	HPST	50	0-67	0.07	5	0.3 FSR	28	0-5
P8	LPSB	0.5	0-3.4	0.01	14	0.02	28	0-5

Note: Component acronyms used in this table are identified in Figure 2-2.



2.2.2. SCE Configuration

The SCE (nominal or redundant) is the electronics unit operating the SCS (nominal or redundant).

Figure 2-6 shows the interface relationships between the SCE, the spacecraft and the other parts of the SCS, together with the top-level redundancy concept of the SCS itself. The two electronics units (Nominal and Redundant) are connected to their respective TMU's, but only one system can be activated and controlled at a time. The nominal SCE is active while the other one is in cold redundancy state. The selection of the working SCE is made by the S/C by selecting the appropriate 28 V lines. A picture of the SCE 2nd Flight Unit is shown in Figure 2-8.

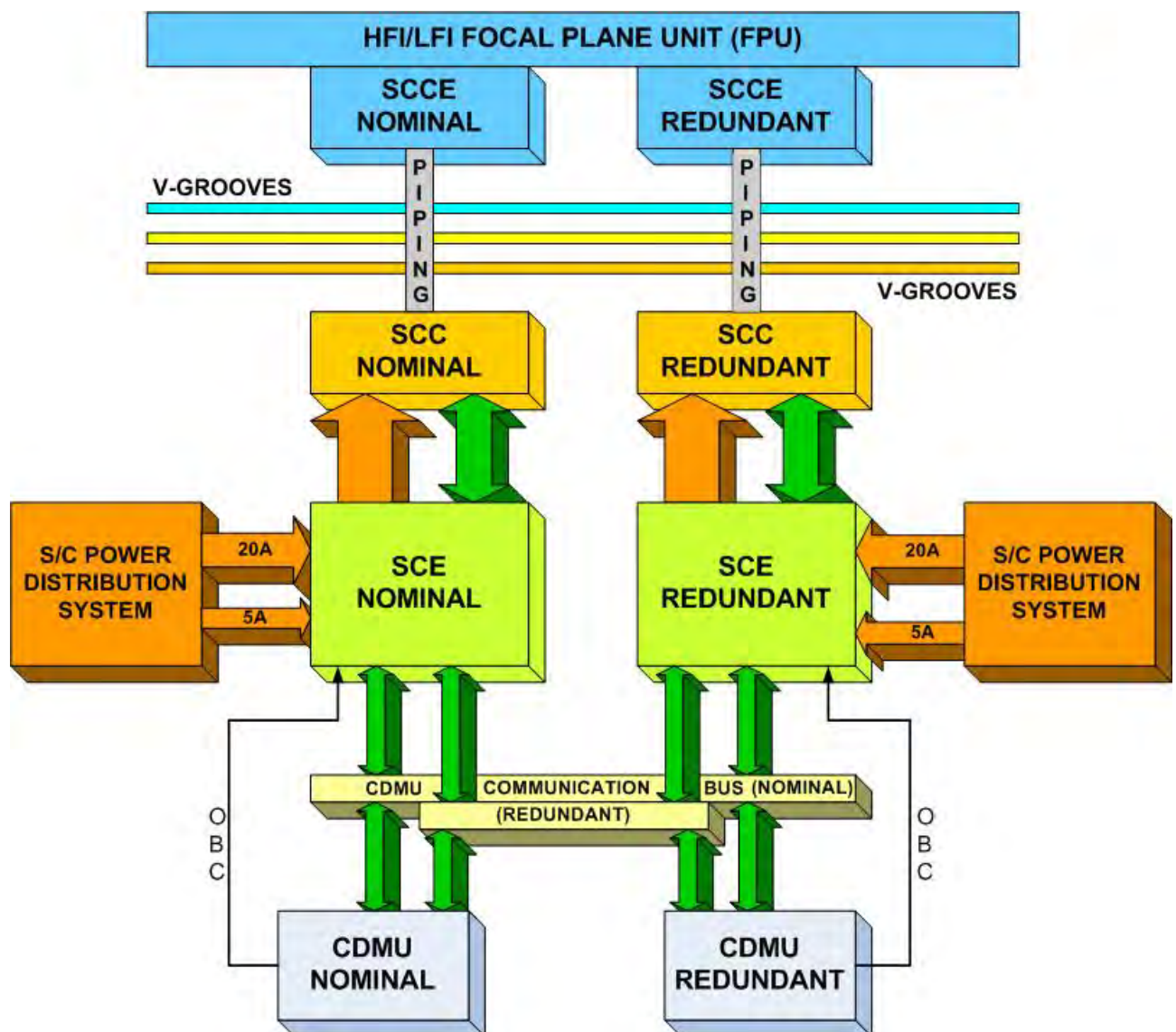

Figure 2-6 Block Diagram of the Sorption Cooler Electronics (SCE) configuration and redundancy with respect to the TMU and S/C (Full internal harness not shown)

Data are received, processed and released to the S/C through the CDMS buses (Nominal and Redundant). The interface with the spacecraft will be able to handle a baseline data rate of 2



kbit/s and will be compliant with the MIL-STD-1553B standard, with the SCE acting as a remote terminal and the CDMS as the bus controller.

The Figure below shows the configuration of electrical interfaces of the SCE.

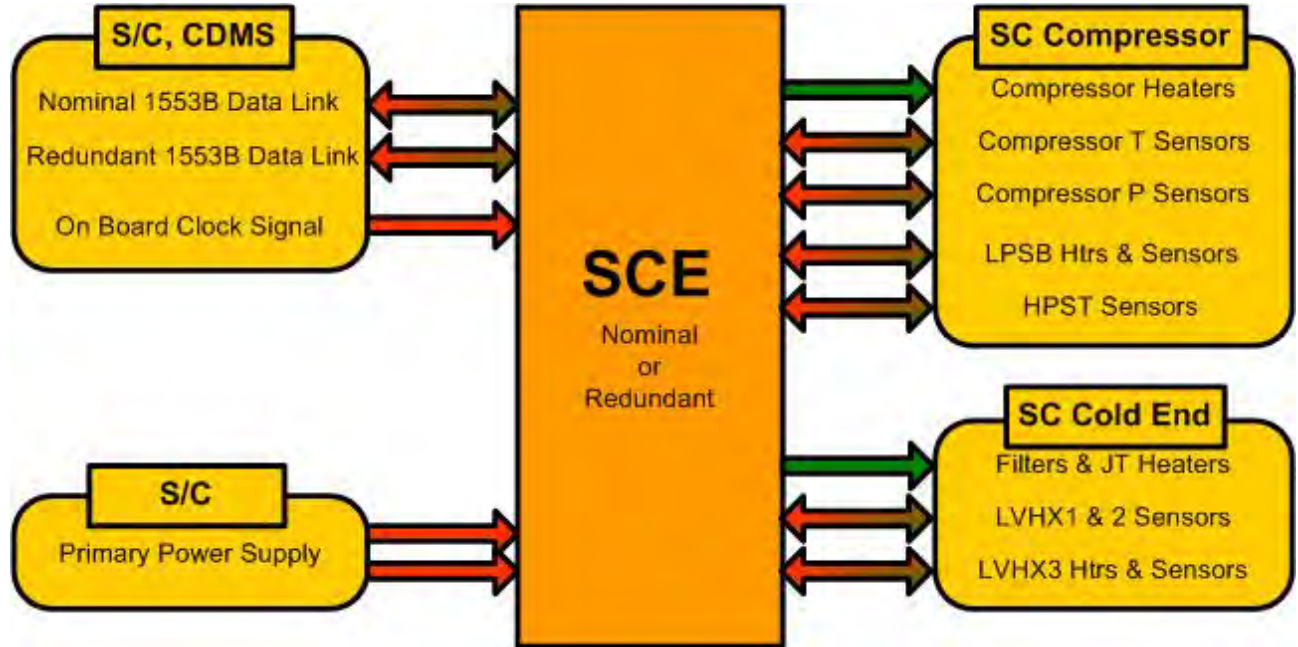

Figure 2-7 SCE electrical interfaces

The electrical I/F of the SCE (mainly connectors and harness) are described in Chapter 4.



Figure 2-8 SCE FM2 Unit front panel



3. Planck Sorption Cooler System Functions

3.1. TMU Functions

The Planck Sorption Cooler is a continuous 20K Joule-Thompson cooler utilizing hydrogen as the refrigerant via alternating chemical absorption and desorption cycles within the $\text{LaNi}_{4.8}\text{Sn}_{0.2}$ alloy compressor elements. This system provides vibration free cooling at 19K by alternating the heating of six individual compressor element assemblies (Table 3-1) which provide the force through this absorption / desorption process.

Hydrogen is circulated about the TMU fluid loop by alternately heating and cooling six containers of metal hydride powder (CE1-CE6) one after another, causing them to release and absorb hydrogen gas by reversible chemical action. The six compressor bed assemblies cycle through four steps from heating, desorption, cooling/absorption, and then absorption.

Check valves (CV) direct the released hydrogen, via heat exchanger piping (HX1-HX4), through successively colder pre-cooler heat sinks (PC1-PC3) and a Joule-Thomson expansion valve (JT). The resulting cold hydrogen fluid collects in liquid reservoirs (LVHX1 & LVHX2) where it removes heat by evaporation. A heater in a third liquid reservoir (LVHX3) eliminates any excess liquid hydrogen. Hydrogen gas then passes back through the heat exchanger piping (HX4-HX1) to other check valves, which return it to the hydride containers where it is re-absorbed.

To help steady the hydrogen flow, a ballast volume (HPST) is situated at the outlet of the hydride containers and a high capacity hydride bed (LPSB) is on the inlet side. Filters (Fn) are positioned about the fluid loop to remove particulate and chemical contaminants. Pressure transducers (Pn) are installed in the fluid loop to complement the externally mounted temperature sensors (Tn). Lead wires from the sensors and the various heaters are collected into several cable bundles that terminate in connectors mounted on the SCC and SCCE, for access by outside electronics.

The TMU is powered and controlled in flight by the Sorption Cooler Electronics (SCE)

3.1.1. Sorption Cooler Compressor (SCC) assembly

The principle of operation of the sorption compressor is based on the intrinsic properties of a metal hydride alloy (namely $\text{La}_{1.0}\text{Ni}_{4.78}\text{Sn}_{0.22}$) able to absorb large quantities of low-pressure hydrogen isothermally at relatively constant pressure and to desorb it at high pressure when heated in a limited volume. Each sorbent bed is periodically cycled between heating and cooling phases, producing high-pressure gas intermittently. The sorbent material sits inside the inner chamber of each bed, separated from the outer shell by a small, thin volume. In order not to lose excessive amounts of heat during the heating cycle, a small and separate quantity of sorbent material can be heated (via a small heater) and cooled (in this case directly by the warm radiator) to fill and evacuate this volume, respectively. In this way it is possible to alternately isolate the sorbent bed from the radiator during the heating cycle, and connect it to the radiator thermally during the cooling cycle.

It is worth mentioning how compression is achieved without mechanical processes: the Planck Sorption Cooler Compressor (SCC) contains no moving parts, aside from 12 check valves, whose diaphragms open and close following cooler cycle. For these reasons the Planck Sorption Cooler can be considered practically vibration-free.

In order to produce a continuous stream of liquid refrigerant, the Planck SCC six sorption compressor elements are operated with staggered phases so that at any given time, one CE is



desorbing high-pressure hydrogen, three are absorbing low-pressure hydrogen, and two are being heated and cooled in preparation for desorption and absorption, respectively (see Table 3-1). In such a system, there is a basic clock time period over which each step of the process is conducted: since each phase lasts ~670 seconds, the cooler total cycle time is ~4000s.

Phase n+1	Phase n+2	Phase n+3	Phase n+4	Phase n+5	Phase n+6
Bed 1: HU	Bed 1: DE	Bed 1: GG	Bed 1: GG	Bed 1: GG	Bed 1: GG
Bed 2: DE	Bed 2: GG	Bed 2: GG	Bed 2: GG	Bed 2: GG	Bed 2: HU
Bed 3: GG	Bed 3: GG	Bed 3: GG	Bed 3: GG	Bed 3: HU	Bed 3: DE
Bed 4: GG	Bed 4: GG	Bed 4: GG	Bed 4: HU	Bed 4: DE	Bed 4: GG
Bed 5: GG	Bed 5: GG	Bed 5: HU	Bed 5: DE	Bed 5: GG	Bed 5: GG
Bed 6: GG	Bed 6: HU	Bed 6: DE	Bed 6: GG	Bed 6: GG	Bed 6: GG

Notes: HU: Heat-up; DE: Desorption; GG: Gas Gap Actuators ON

Table 3-1 SCC staggered phases

In addition to the sorbent beds, the compressor contains 4 1-liter ballast volumes plumbed into the high-pressure outlet of the compressor, denoted cumulatively as the High-Pressure Stabilization Tank (HPST), which serve to reduce the pressure and mass flow variations that arise from turning the 6 compressor elements ON and OFF. Figure 3-1 depicts the Planck hydrogen sorption cooler compressor assembly.

Since the temperature of the saturated liquid in the LVHX interfaces is solely governed by its vapor pressure, the ability of the sorbent material to absorb hydrogen at constant pressure plays the key role in determining the operational temperature of the cold end and in minimizing temperature fluctuations. For this reason, at the low-pressure side of the compressor is a Low-Pressure Storage Bed (LPSB), which uses the same type of sorbent material as the CE's, but in higher quantity, for a dual purpose: on one side it is able to store the hydrogen in the cooler at sub-atmospheric pressure when the cooler is not operating; on the other side, it can partially reduce pressure oscillations in the low pressure line.

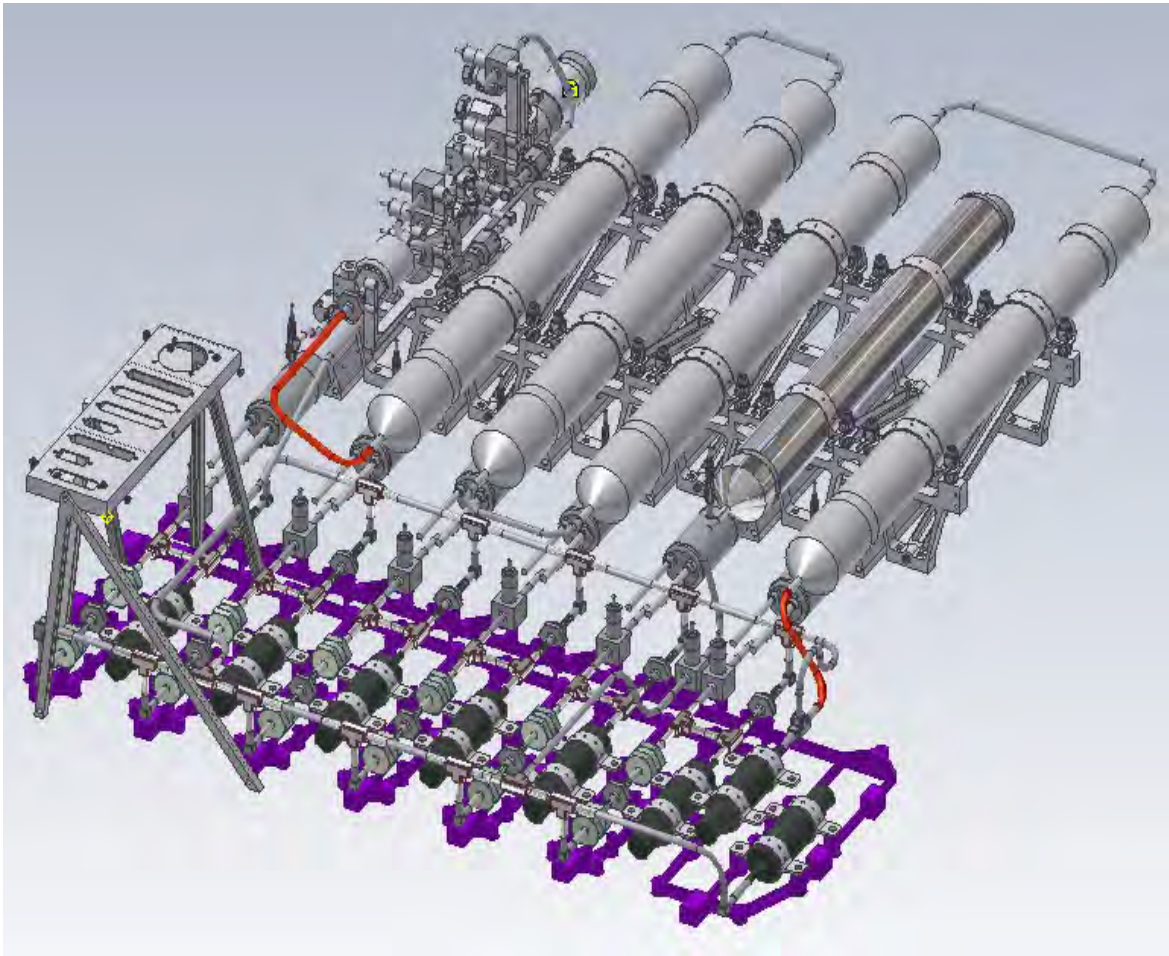

Figure 3-1 The Planck Sorption Cooler Compressor

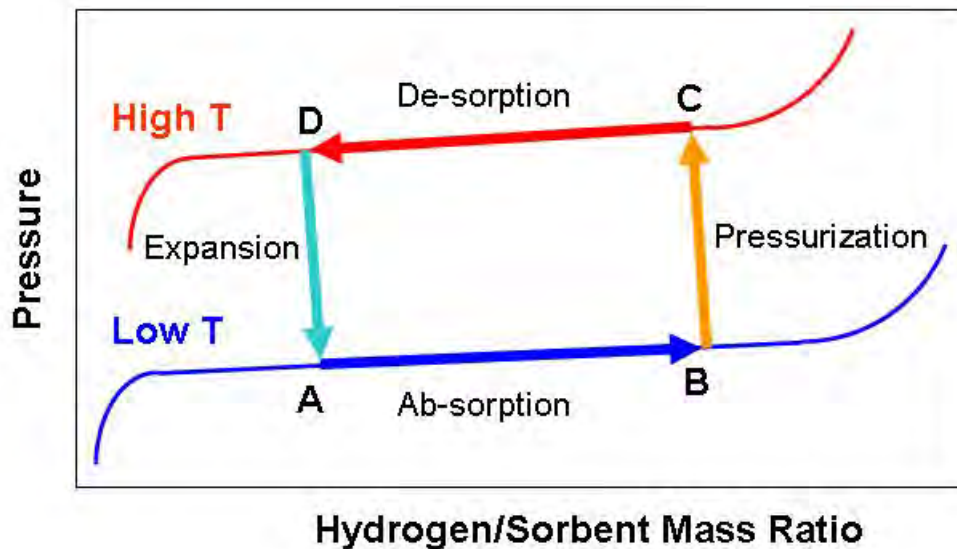

Figure 3-2 Hydride Isotherms

The mass of hydrogen stored in a unit mass of sorbent is plotted on the horizontal axis vs. the pressure on the vertical axis in Figure 3-2. Each curve is an “isotherm” representing the



dependence of mass of hydrogen stored on the sorbent vs. the pressure at a constant temperature. The sorbent in contact with hydrogen gas can exist at equilibrium anywhere on one of the isotherms. If hydrogen is added to or removed from the sorbent at constant temperature, the system will move along an isotherm. Absorption of hydrogen at constant low temperature is represented by the line A → B. Heating from low T to high T in a confined space is represented by B → C. Continuously removing hydrogen from the sorbent at constant temperature is represented by C → D. Cooling depleted sorbent from high to low temperature in a confined space is represented by D → A.

As a sorption compressor element (i.e. sorbent bed) is taken through these four steps in a cycle, it will intake low-pressure hydrogen and output high-pressure hydrogen on an intermittent basis.

The minimization of low-pressure fluctuations by the buffer LPSB is based on the same principles. Because of the slope of the A-B line in Figure 3-2, if the pressure in the low-pressure manifold drops, this buffer bed will release hydrogen, and if the pressure rises, it will absorb hydrogen.

Initially, it was assumed that the rare earth metal hydride would not have any aging issues. However, testing has shown that hydride capacity degradation occurs. This degradation is a function of the pressure cycles, time at elevated temperature, and the fraction of the material in the β -phase during elevated temperatures. This process can be reversed by subjecting the alloy to elevated temperatures under reduced pressures at the expense of gas gap degradation. Although the number of regeneration cycles the gas gaps can survive is limited, the cooler will need at most one regeneration cycle during the planned life of the experiment.

3.1.2. PACE Functions

The high pressure gas leaving the Compressor, enters the PACE (Piping Assembly and Cold End) and flows through heat exchanger piping (HX1-HX4) for heat recovery by the cold low pressure returning gas stream. The H_2 is also pre-cooled through successively colder pre-cooler heat sinks (PC1-PC3, respectively at about 170 K, 100 K and 50 K) on each spacecraft thermal shield (or V-groove).

The high pressure gas produced by the SCS Compressor is expanded through the JT flow restriction valve and the liquid hydrogen is collected in the two reservoirs (LVHX1 and LVHX2) where the liquid droplets evaporation provides the cooling power to the instruments. A third liquid reservoir (LVHX3) collects any excess liquid hydrogen. Hydrogen gas then passes back through the heat exchanger piping (HX4-HX1) in the low pressure line, which return it to the hydride containers where it is re-absorbed.

Filters (Fn) are positioned about the fluid loop to remove particulate and chemical contaminants. Pressure transducers (Pn) are installed in the fluid loop to complement the externally mounted temperature sensors (Tn) for system monitoring and control. Lead wires from the sensors and the various heaters are collected into several cable bundles that terminate in connectors mounted on the Compressor and Cold End, for access by outside electronics.

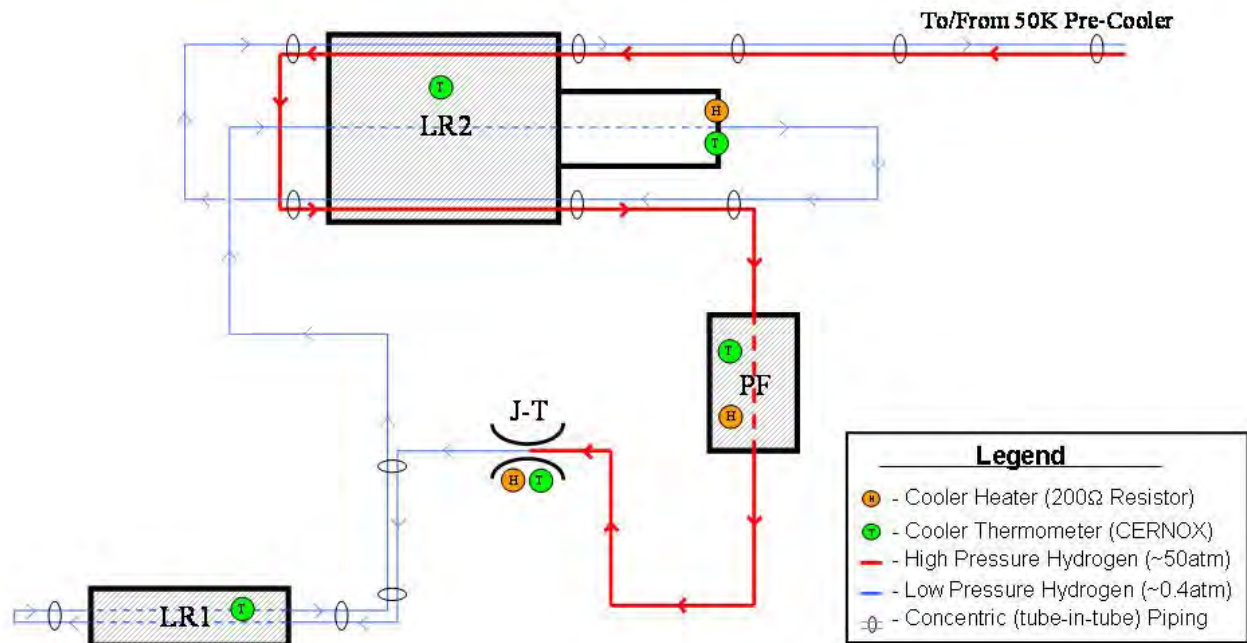

Figure 3-3 SCCE functional description

3.2. SCE Functions

The SCE (nominal or redundant) is an electronics unit, which operate the SCS (nominal or redundant). The **functions** to be provided by the electronics:

- ▶ Sense temperature sensors
- ▶ Time and control of the compressor heaters (including thermal switch actuation).
- ▶ Sense pressure transducers
- ▶ Read up-link parameters and write down-link parameters through communication with the S/C
- ▶ Warm-up of the J-T and the coldest filter
- ▶ Convert and condition electrical power to be used by the compressor assembly heater circuits, low-power heater circuits and the electronic circuits
- ▶ Process periodic ground uplink commands or a command table to modify control parameters (switch times, control values such as warning levels, and heater levels) to enable optimization of cooler performance in the actual flight environment and to accommodate aging of the cooler and the temperature surrounding environmental surfaces on-orbit
- ▶ Control to maintain constant power during heating and desorption, and to accommodate degradation (end-of-life performance) of the cooler (i.e., compressor assemblies)
- ▶ Provide closed-loop control of the TSA temperature based on temperature and heater power feedback



- ▶ Perform internal diagnostics and appropriate responses to protect the sorption cooler from catastrophic failures
- ▶ Control the compressor assemblies operating in sequence to maintain a constant cold-head temperature
- ▶ Monitor compressor temperatures, pressures and power

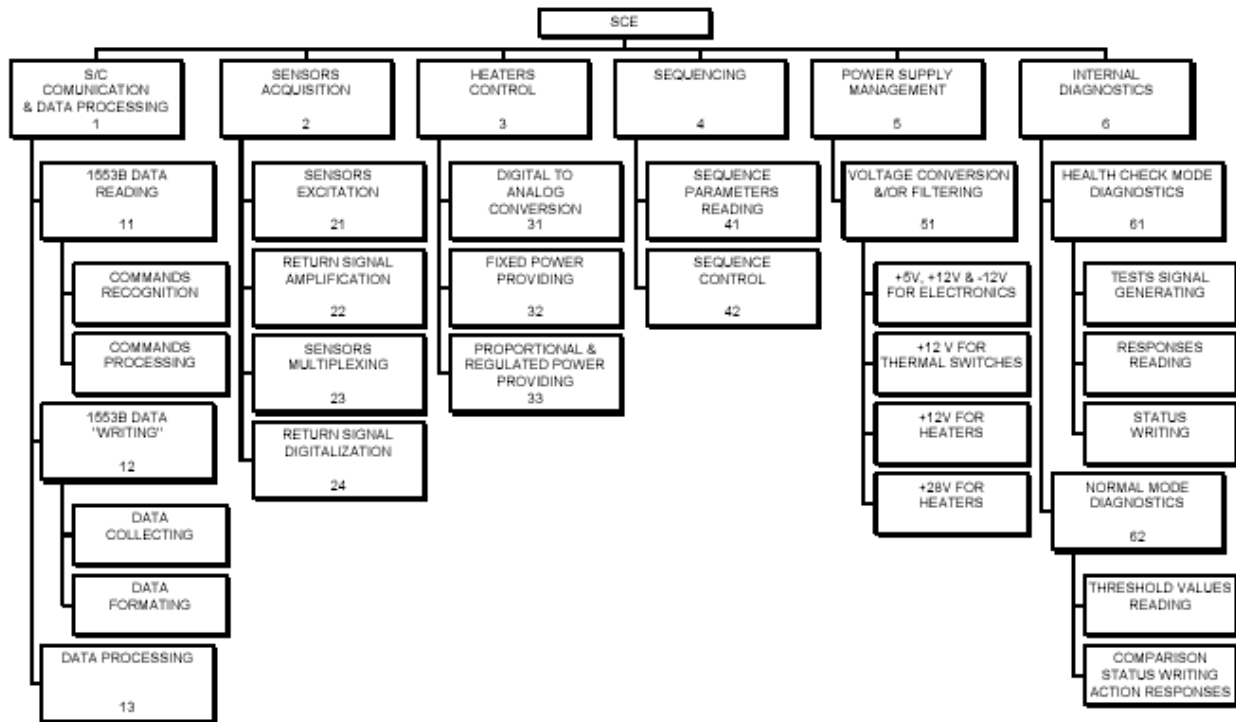

Figure 3-4. SCE functional diagram

Figure 1-2 (Chapter 1) shows the interface relationships between the SCE and the other parts of the SCS, together with the top-level redundancy concept of the SCS itself:

The nominal SCE is active while the other one is in cold redundancy state. The selection of the working SCE is made by the S/C by selecting the appropriate 28 V lines.

The interface with the spacecraft will be able to handle a baseline data rate of 2 kbit/s and will be compliant with the MIL-STD-1553B standard, with the SCE acting as a remote terminal and the CDMS as the bus controller.

In the following **Figure 3-5**, the functional diagram of the SCE is displayed.

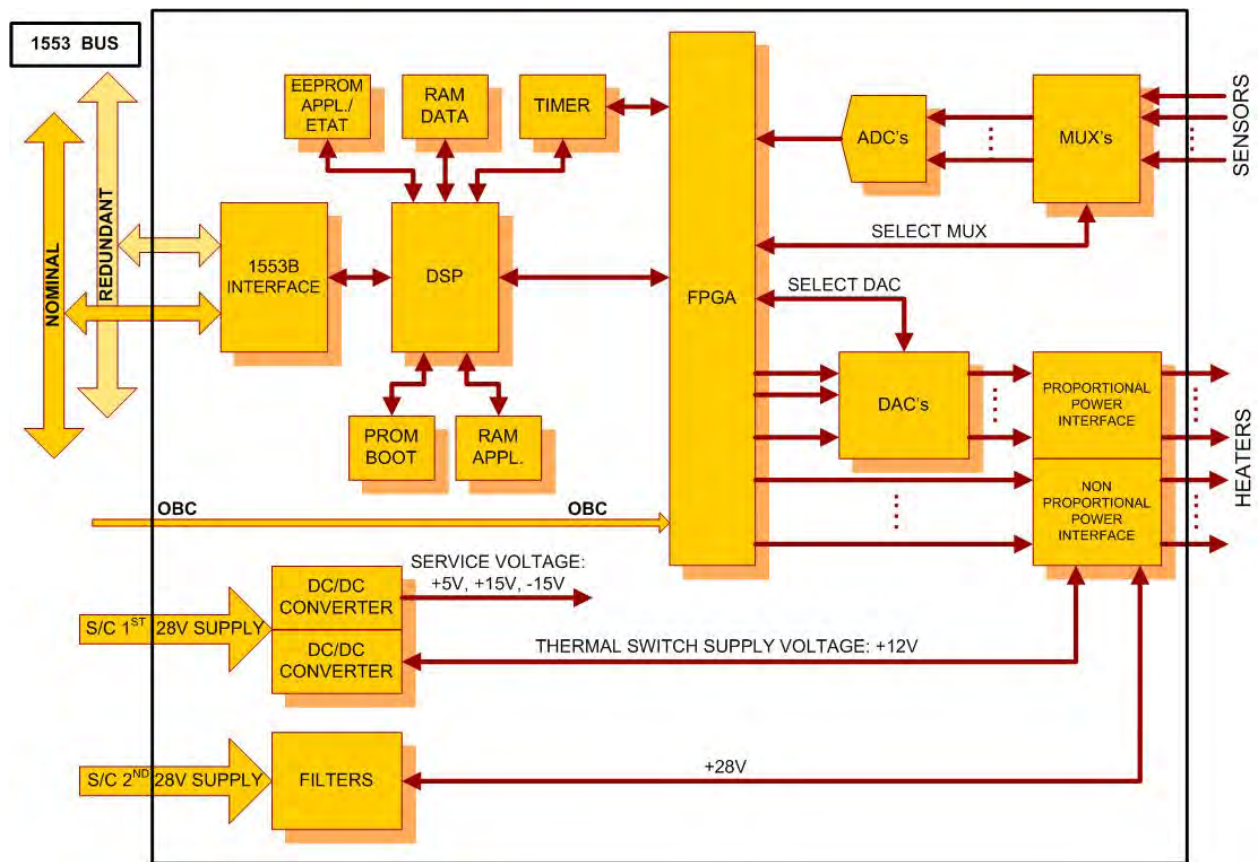

Figure 3-5 SCE functional block diagram

For commonality purposes, the CPU used in the SCE will be the ATMEL TSC21020, which is a Digital Signal Processing (DSP), developed by Analog Devices and implemented for flight use by ATMEL.

The CPU board will be based on this chip (16 MHz clock), with appropriate timers for on board time management, with radiations tolerant memories and components.

The SCE subsystem will include three DC/DC converters of two types with a nominal input DC voltage of 28 V and +5V, +15V, -15V and 31V for the first type (CVSQ40) and +12V for the second type (MCV1150D). The specifications of the DC/DC converter can be found in the manufacturer (Alcatel) document (RD1, RD2).

The SCE will also contain ADCs and Multiplexer components allowing the read data from the sensors (voltage, current, temperature and pressure). The interface toward the heaters will be realized with DAC's components and power MOS radiations tolerant transistors.

Data communication interface will be implemented following the MIL-STD 1553B standard, through one nominal and one redundant transformer in the long stub configuration.

The figure below shows the Data processing and communication functional diagram for the SCE.

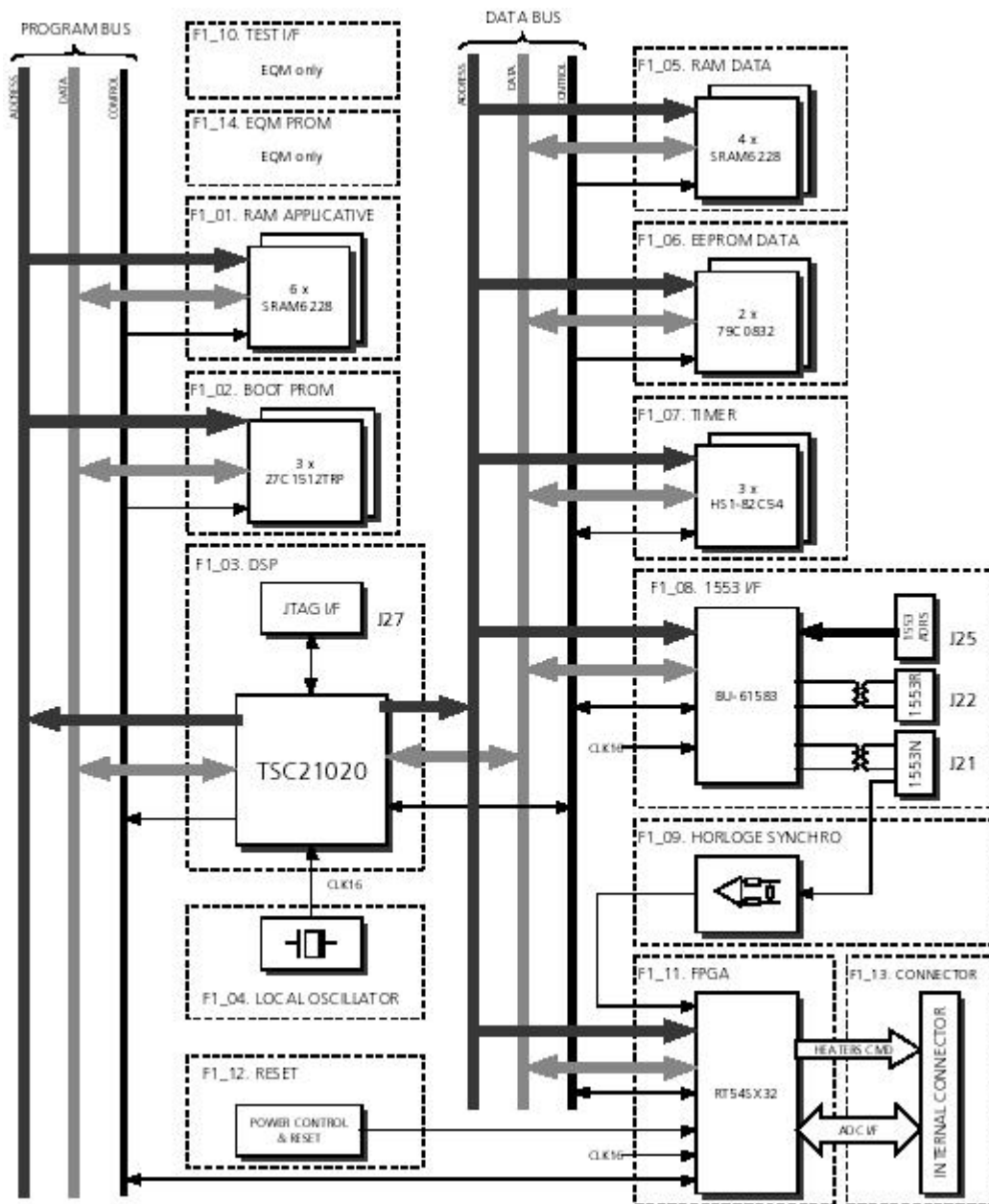

Figure 3-6 SCE Data processing diagram SCE Data processing diagram

The diagram shows the Floating-point DSP processor surrounded by the appropriate memories as listed below:

32K x 48 bits PROM, "ROM de Boot" containing the boot software, hardware power on, initializations, tests routines and the minimum software segment to be able to operate the system (survival software). No patch possibility.

128K x 48 bits SRAM, "RAM Applicatif", including the Sorption Cooler control and the data communication software.

128K x 32 bits EEPROM, "EEPROM Prog.", loaded with the two last revision of the OBSW.

128K x 32 bits EEPROM, "EEPROM Etat", a memory of the elements characteristics and the current state of the cooler.

128K x 32 bits SRAM, "RAM Data", Working Memory and HK data buffer.



After a boot, the software is transferred from the EEPROM to the SRAM allowing it to be completely independent of the boot software and to be patched during execution. More over, the power consumption is lower when the software is executed in SRAM rather than PROM and the execution speed increase (access time in SRAM= 16ns, in EEPROM= 200ns).

The figure below shows the CDMU interface diagram.

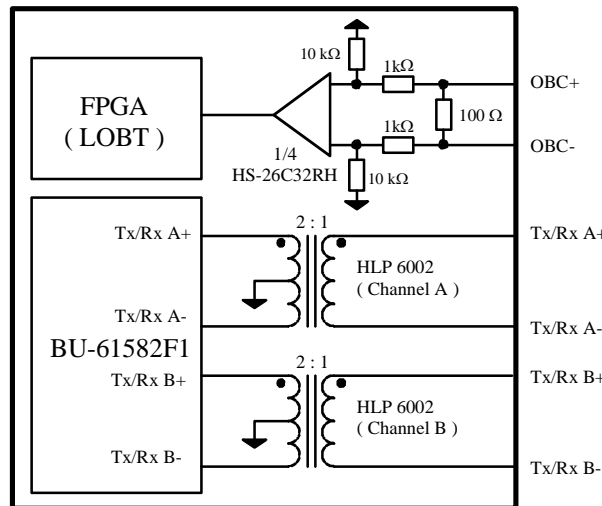

Figure 3-7 SCE CDMU interface diagram

This interface diagram is for one SCE (nominal or redundant). It shows the interconnection with the On Board Clock signal (OBC) and the two channel of the 1553B bus from the CDMU.

3.2.1. Sensors acquisition

3.2.1.1. Pressure sensors acquisition diagram

The figure below shows the pressure sensors acquisition circuits.

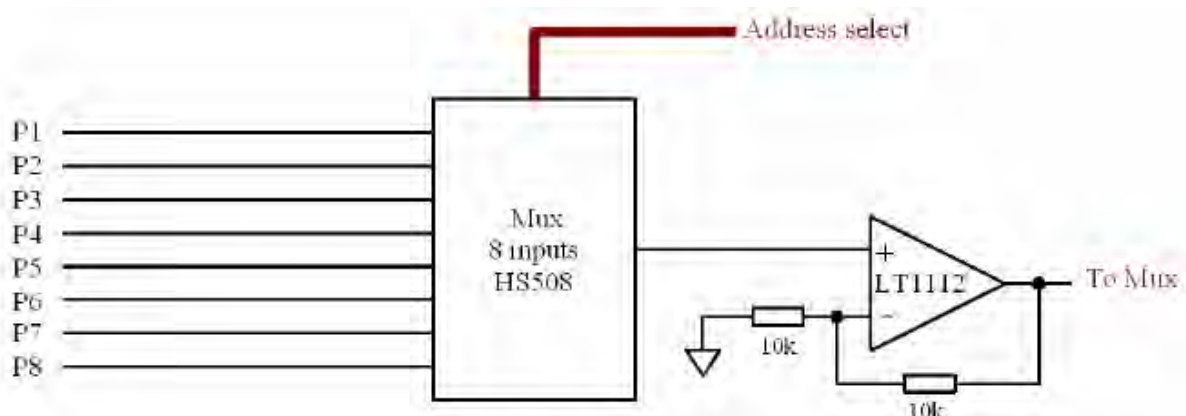



3.2.1.2. Temperature sensors acquisition diagram

3.2.1.2.1. Thermocouples

The figure below shows the thermocouples temperature sensors acquisition circuits.

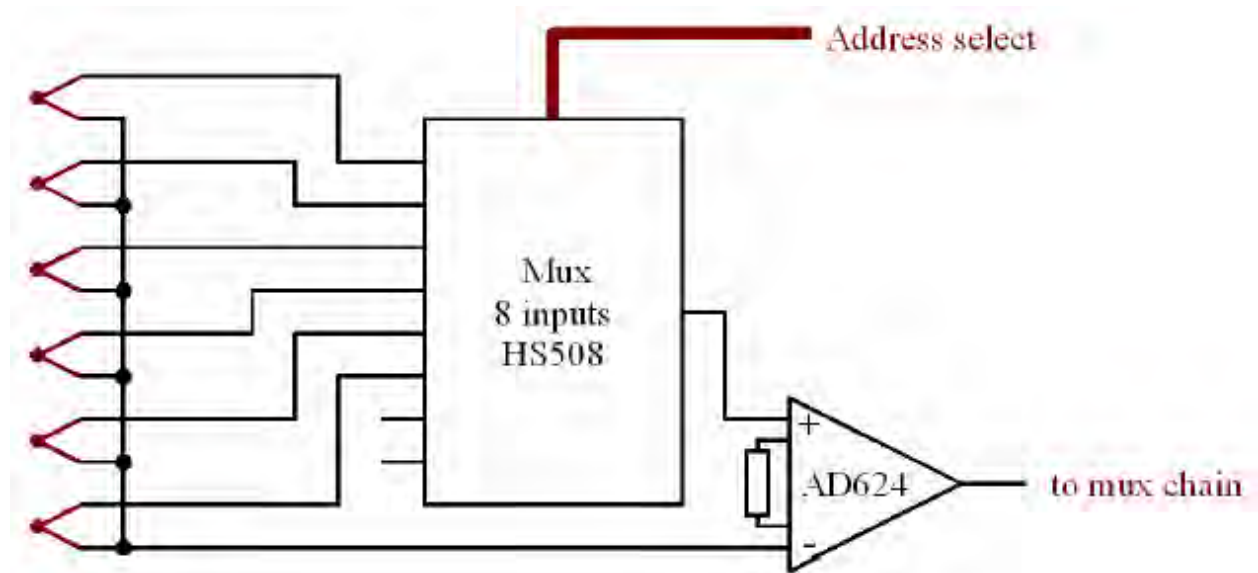

3.2.1.2.2. RTD Sensors

The figure below shows the RTD temperature sensors excitation circuits.

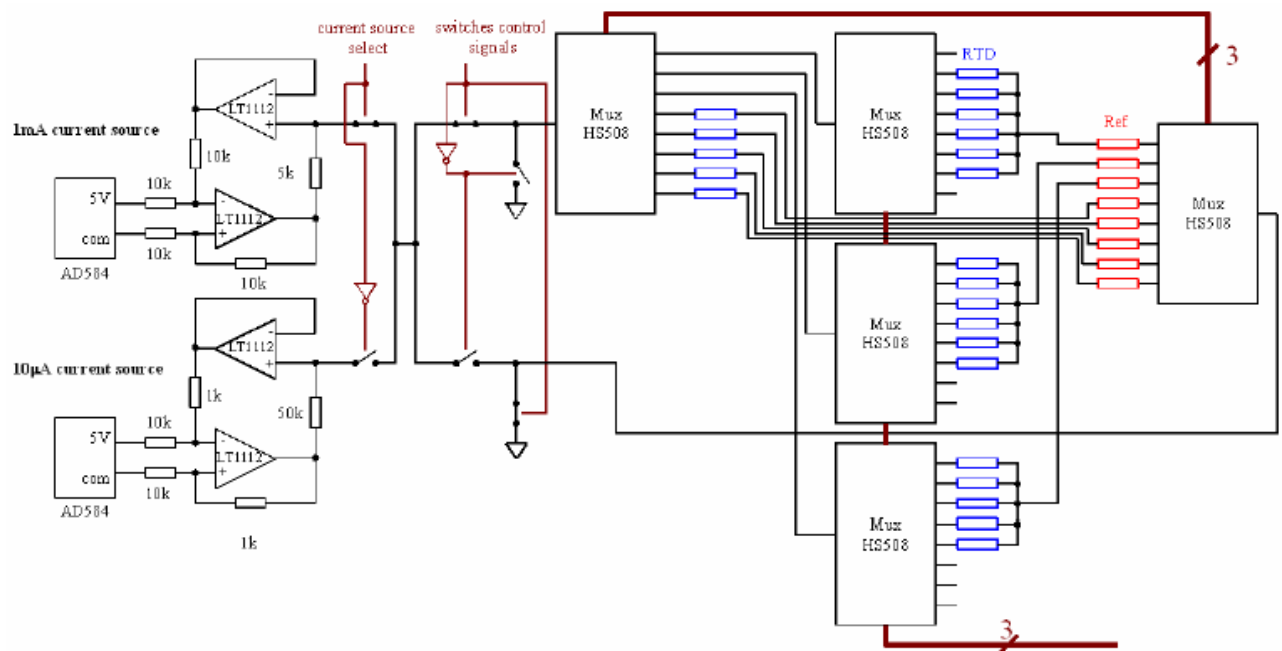



The figure below shows the RTD temperature sensors acquisition circuits.

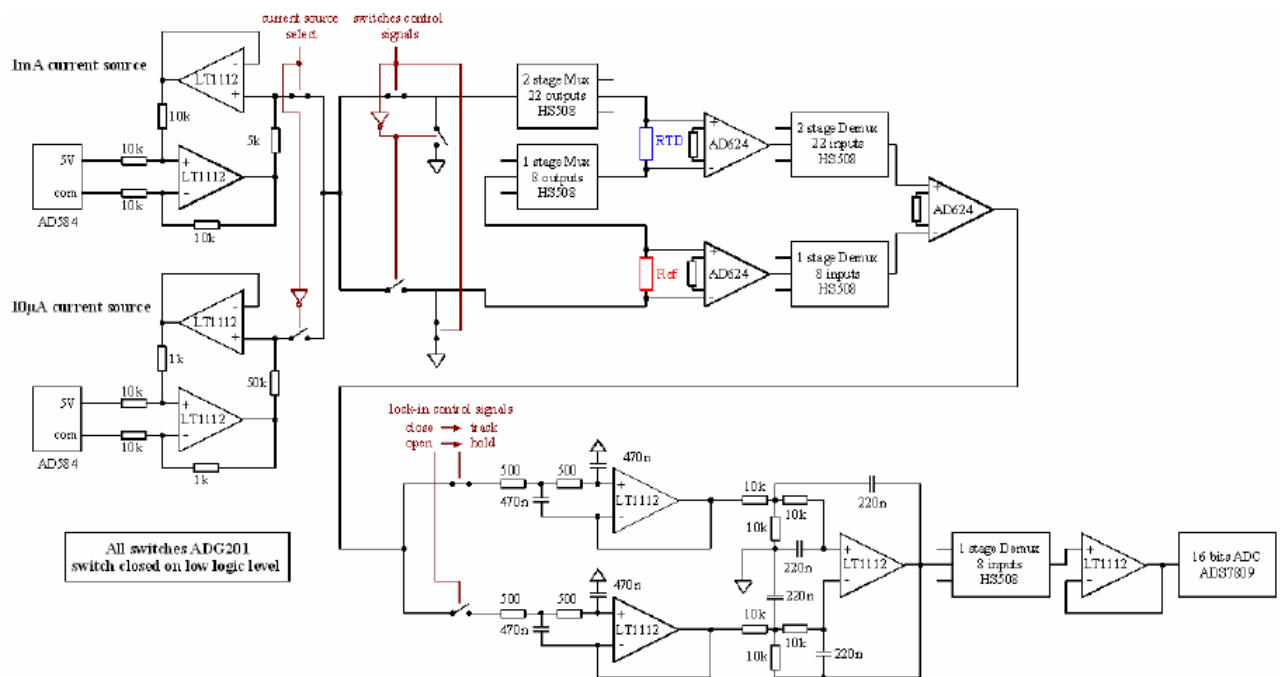

RTD are resistive element which resistance varies with temperature. Reading a temperature from this kind of sensor is thus equivalent to measuring a resistance value. This is traditionally done by exciting the resistive element with a known and constant DC current and by measuring the voltage drop across the sensors.

Errors due to the resistance of the wiring can be greatly reduce by using four wires sensors: two wires are used to carry the current to the resistive element and the two other wires are used to measure the voltage drop with an high input impedance instrumentation amplifier.

Electronics parts (instrumentation amplifiers in our case) have usually poor DC performance due to uncontrollable offsets voltages, bias currents, low frequency noise (1/f noise), etc.

To achieve the desired performances an AC excitation must be used. Any kind of null mean value current waveform can be used in theory, but the simplest is to use a square wave current excitation. The AC current source is made from a simple DC current source by switching the current from one side to the other each half-period. The switching frequency is chosen to be 1 kHz.

To reduce the dynamic needed for the readout unit a reference resistor which value is the minimum value of the RTD in the temperature range is added in the current path. The voltage drop across this resistor is then subtracted to the voltage drop across the sensor.

The readout voltage goes through a lock-in amplifier in order to restore the DC level that should have been read on the RTD. The lock-in consists in two track-and-hold amplifiers. Each one is holding one polarity of the readout signal. The negative signal is then subtracted to the positive one and the result is a DC signal proportional to the RTD value then the temperature.

Other advantage of lock-in amplifiers is noise rejection. Since lock-in operation is similar to a modulation of the sensor signal and a demodulation of the amplified signal, any frequency component induced before is rejected around the modulation frequency.



3.2.1.3. Read Out acquisition diagram

The figure below shows the Read Out sensors acquisition circuit.

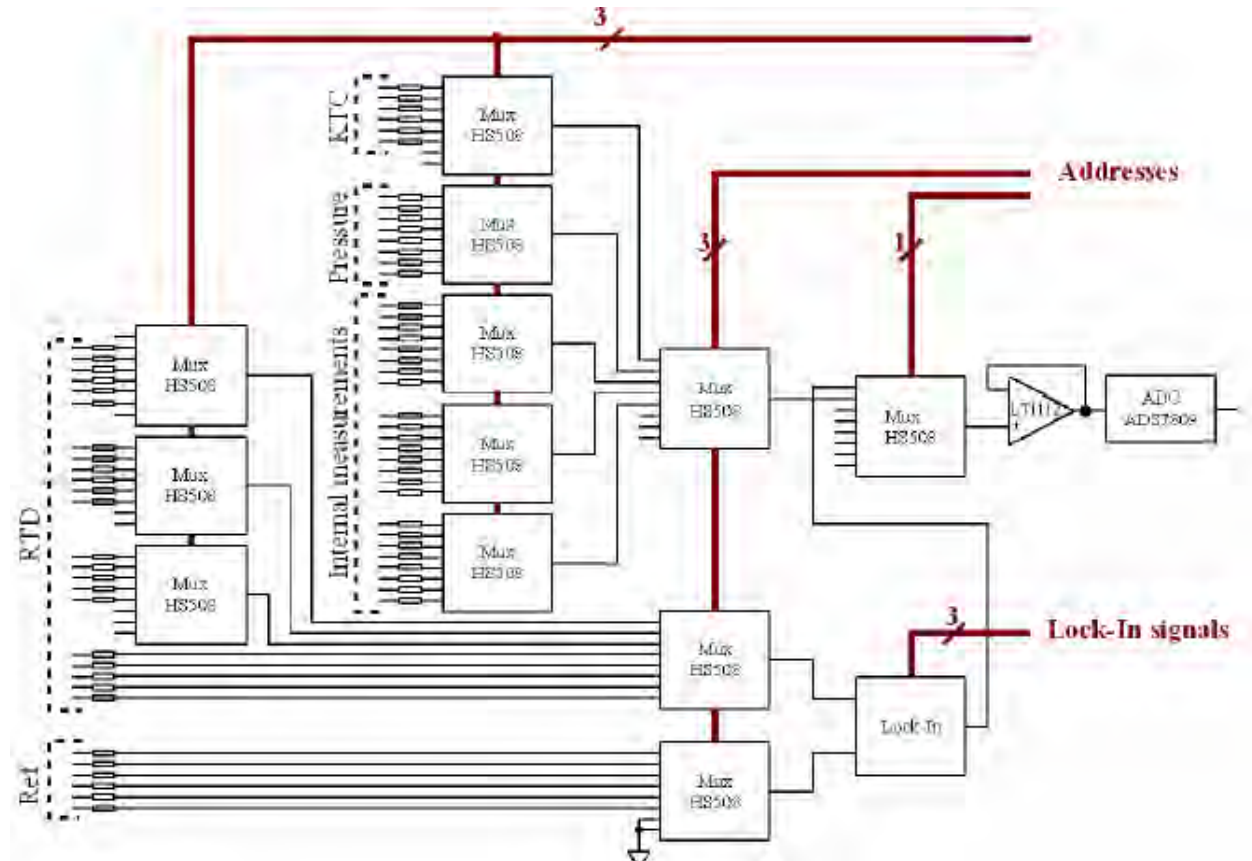

The readout part shown here is fully redundant.

3.2.2. Power Handling

3.2.2.1. Power Distribution

The power supply for the SCE will be realized by two different type of space qualified DC/DC converter designed by Alcatel, CVSQ40 and MCV1150D (RD1, RD2), from the S/C primary power supply.

The figure below shows the power distribution diagrams.

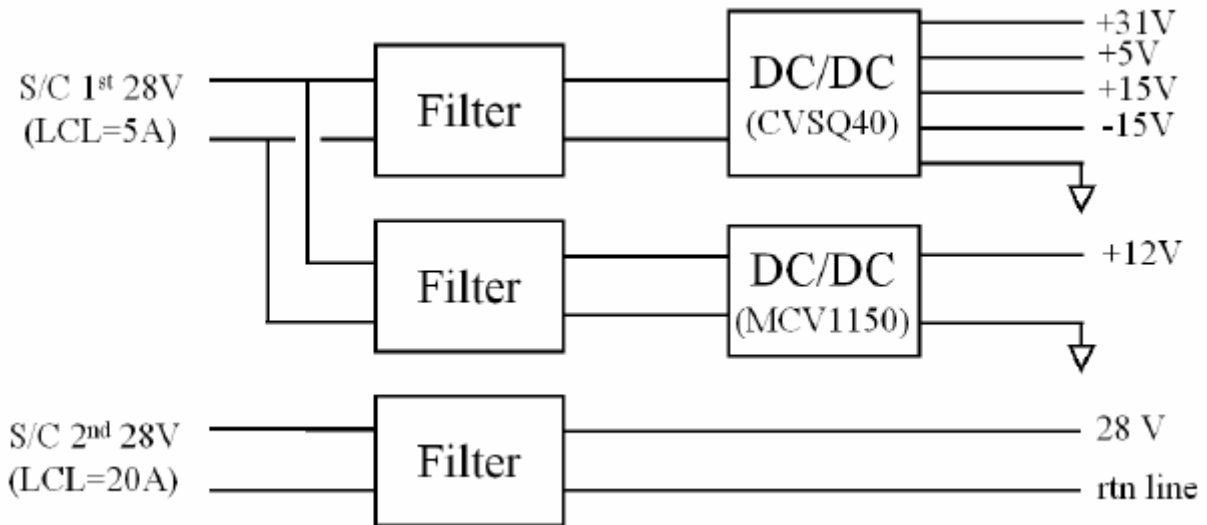

3.2.2.2. Power Control

3.2.2.2.1. Compressor Heaters

The figure below shows the power control diagram for the compressors heaters including thermal switches heaters.

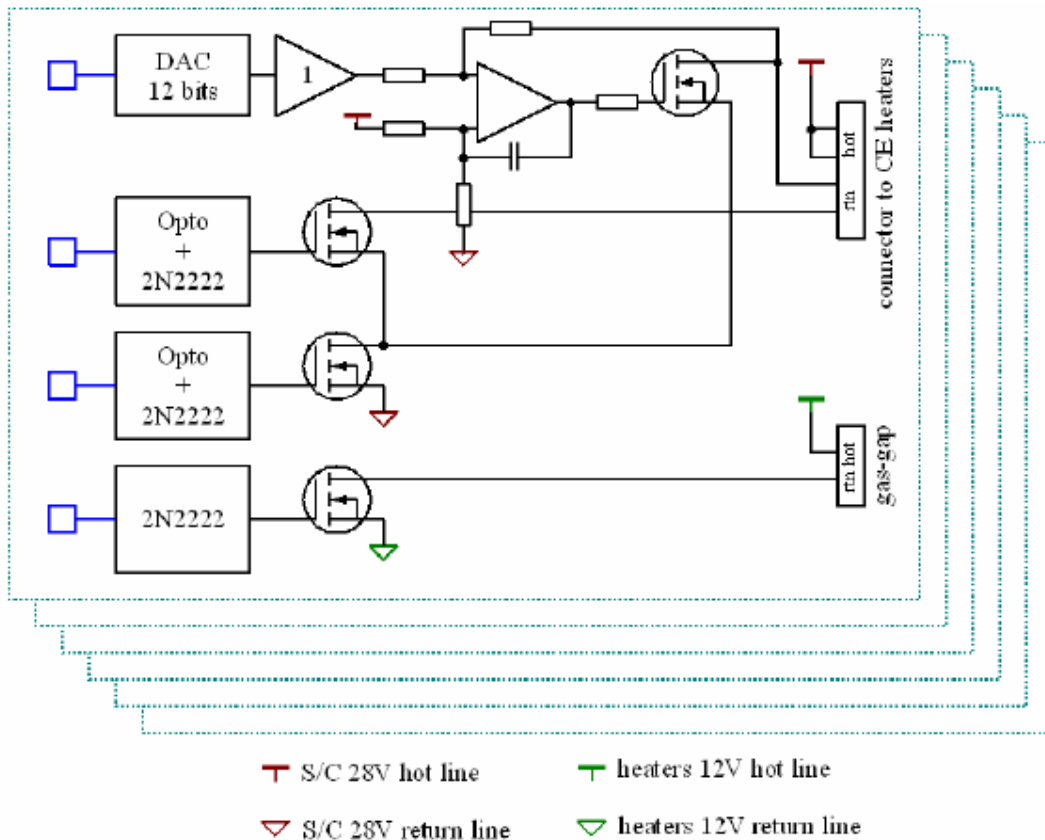



3.2.2.2.2. Others Heaters

The figures below shows the power control diagram for the other heaters

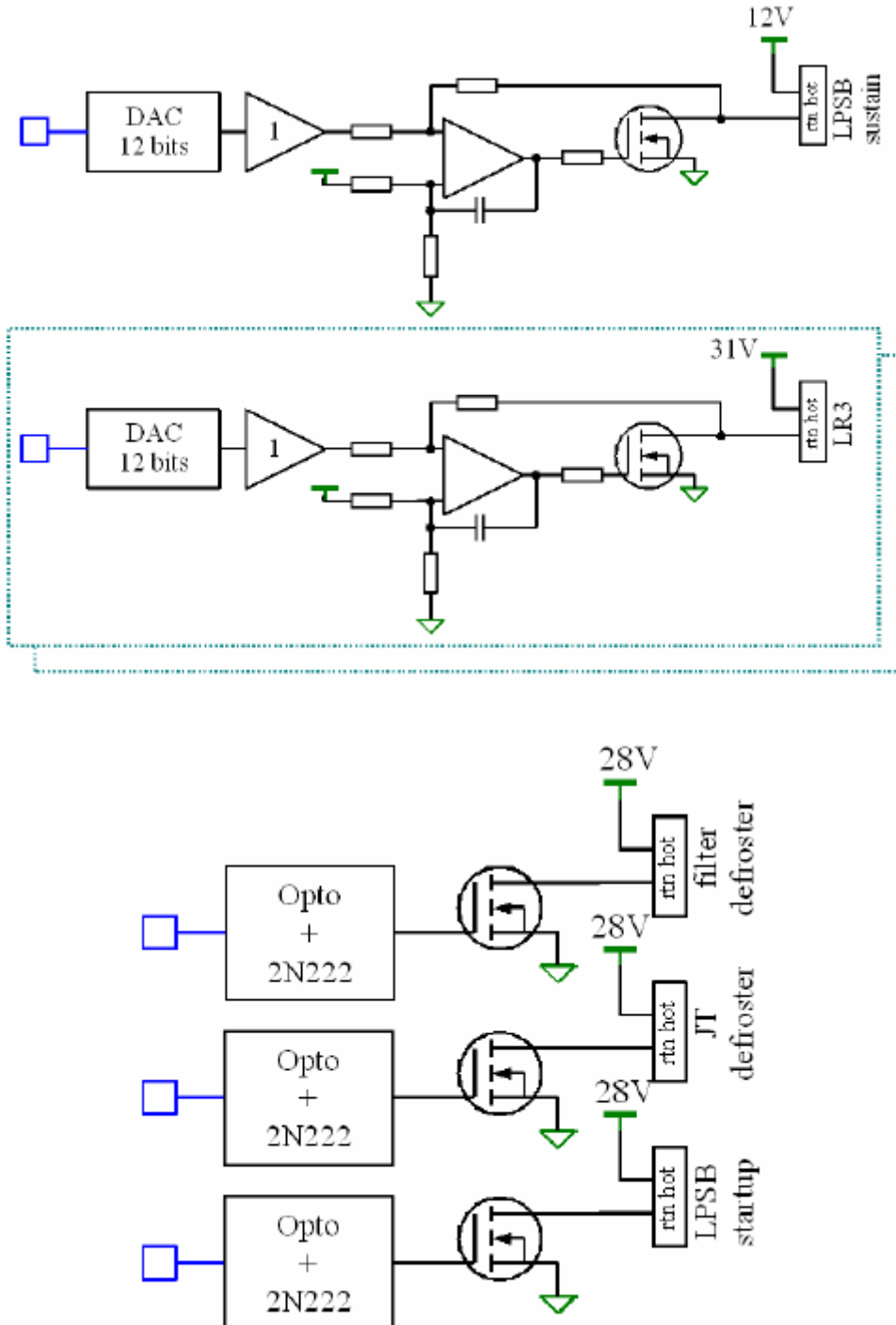



4. Planck Sorption Cooler System Interfaces

4.1. SCS Interfaces with the Spacecraft

Each individual Sorption Cooler Subsystem unit is allocated a unique identification codes: a project code which is the normal reference used for routine identification in correspondence and technical descriptive material.

The whole SCS is functionally split as in the following table:

S/S Code	S/S Name & Acronym
PSM	Planck Sorption Cooler (Nominal, on spacecraft -Y side)
PSR	Planck Sorption Cooler (Redundant, on spacecraft +Y side)

The elements of this subsystem are «units» and are identified under ESA's identification codes. The project codes allocated to the SCS units are:

PSM1	Sorption Cooler Cold End (SCCE) (Nominal)
PSM2	Sorption Cooler Pipes + pre-coolers 1,2,3 A, B,C and support and cryo-harness SCC to pre-coolers (Nominal) and cryo-harness from SCCE to charcoal filter bracket
PSM3	Sorption Cooler Compressor (SCC) (Nominal)
PSM4	Sorption Cooler Electronics (SCE) (Nominal)
PSM5A/5B	SCE to SCC Harness (Nominal)
PSM5C	Subplatform bracket 300K to charcoal filter bracket 50K (including subplatform bracket) harness nominal
PSM5D	SCE to subplatform bracket 300K (excluding bracket) harness nominal
PSR1	Sorption Cooler Cold End (SCCE) (Redundant)
PSR2	Sorption Cooler Pipes + pre-coolers 1,2,3 A, B,C and support and cryo-harness SCC to pre-coolers (Redundant) and cryo-harness from SCCE to charcoal filter bracket
PSR3	Sorption Cooler Compressor (SCC) (Redundant)
PSR4	Sorption Cooler Electronics (SCE) (Redundant)
PSR5A/5B	SCE to SCC Harness (Redundant)
PSR5C	Subplatform bracket 300K to charcoal filter bracket 50K (including subplatform bracket) harness redundant
PSR5D	SCE to subplatform bracket 300K (excluding bracket) harness redundant

Notes :

The subsystem PSM1+PSM2+PSM3 is called TMU (Thermo Mechanical Unit)

The subsystem PSM1+PSM2 is also called PACE (Pipes Assembly and Cold End)



4.2. TMU MECHANICAL INTERFACES

4.2.1. On SVM

The SCC mounted on the SVM radiator will have attachment points for fixation. The hole pattern on SCC side is given in the SCC interface drawing in annex. The second SCC interface bolt pattern is identical.

The SCC will bolt directly to the radiators through a heat pipe network. Some of the bolts will also connect directly the heat pipes to the SCC. A lifting-and-transportation fixture will be used to support the beds prior to assembly on the flight radiator. This GSE assembly will be removed after the compressor assembly is mounted to the radiator. The mounting bolts are to be inserted from the space side of the radiator through provided through-holes. Primary structural support for the SCC's is provided by the SVM radiator thereby eliminating the need for a separate mounting plate on the SCC. The SCC compressors are sensitive to mechanical stress from the interface bolts under worst case conditions.

The interface at the radiator has therefore to be designed to account for this sensitivity, considering also the allowed temperature variations.

The thermal interface requirements of the SCC compressors to the radiator are defined in Paragraph 4.3.1

The following SCS units will be installed onto the SVM:

- ▶ PSM3 (SCC Nominal) - on SVM radiator on -Y side
- ▶ PSR3 (SCC Redundant) - on SVM radiator on +Y side
- ▶ PSM2 (SCP Nominal partly)
- ▶ PSR2 (SCP Redundant partly)
- ▶ PSM4 (SCE Nominal)
- ▶ PSR4 (SCE redundant)
- ▶ PSM5A/PSM5B (Harness SCE to SCC Nominal)
- ▶ PSR5A/PSR5B (Harness SCE to SCC Redundant)
- ▶ PSM5D (Harness from SCE to subplatform bracket 300K (Nominal))
- ▶ PSR5D (Harness from SCE to subplatform bracket 300K (Redundant))

4.2.2. On Planck P/L Module (PPLM)

4.2.2.1. Cooler and Piping

The SCCE (both nominal and redundant) which are integrated with the LFI FEU (PLFEU) and the HFI FPU, are connected to their corresponding nominal and redundant SCC by the nominal and redundant SCP. The length of the different pipes section shall be



Heat exchanger section	Length	Tolerance
SCC to VG1	1.5 m	+/-10 cm
VG1 to VG2	1.5 m	+/-10 cm
VG2 to VG3	3.0 m	+/-10 cm
VG3 to 18/20K stage	3.5 m	+/-10 cm

The cooler piping will be thermally connected with the heat shields of the PPLM; service loops between each connection stage will relax vibration/mechanical stress on PLFEU.

The following SCS units will be installed onto the PPLM

- ▶ PSM1 (SCCE Nominal)
- ▶ PSR1 (SCCE Redundant)
- ▶ PSM2 (SCP Nominal)
- ▶ PSR2 (SCP Redundant)
- ▶ PSM5C (Cryoharness from subplatform bracket 300K to 50K (Nominal))
- ▶ PSR5C (Cryoharness from subplatform bracket 300K to 50K (Redundant))

4.3. TMU THERMAL INTERFACES

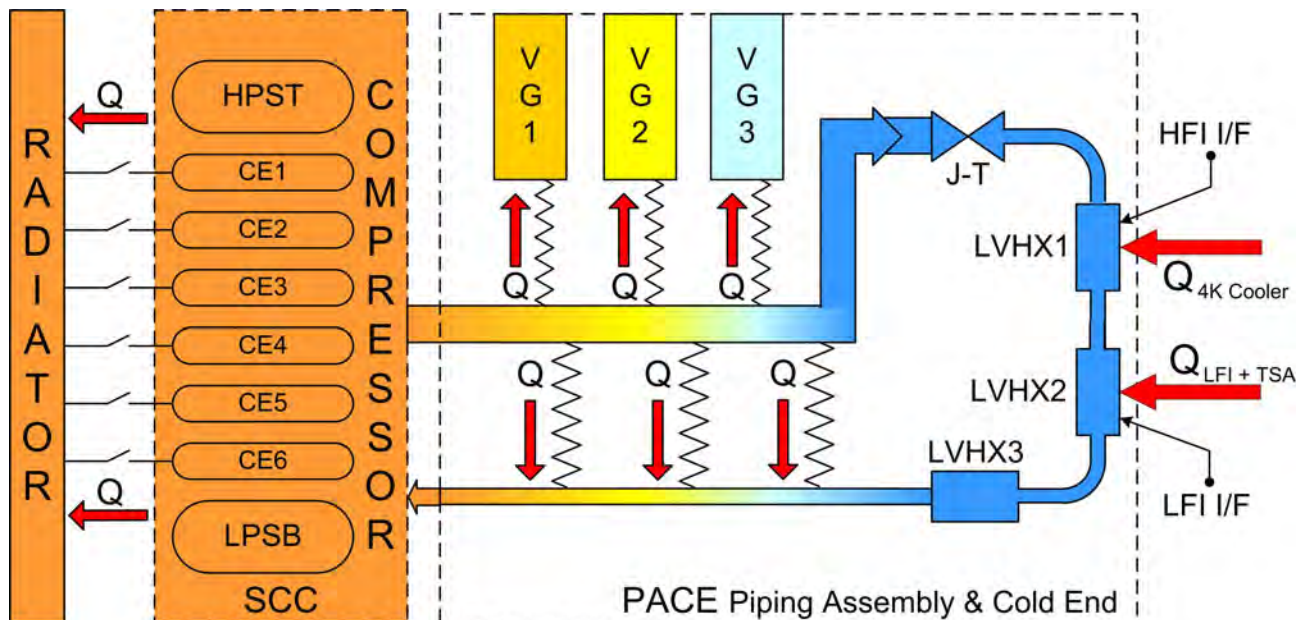

Figure 4-1 TMU thermal configuration

The TMU has five major thermal interfaces (see Fig.2-2):

- ▶ The Compressor Elements thermally and mechanically anchored to the SVM Warm Radiator



- ▶ Three precooling stages on the V-Grooves
 - PC1 used to download heat to V-Groove 1
 - PC2 rejecting heat to V-Groove 2
 - PC3 anchored to the coldest V-Groove 3, split in three heat exchangers to improve thermal contact and exchange (PC3A, B and C)
- ▶ LVHX1 interfaces to the HFI working as a precooling stage for the 4K cooler
- ▶ LVHX2, through the stabilized stage TSA, provides the T reference for the LFI

4.3.1. On SVM

The table below shows the required design temperatures at the interfaces of the SCS units with the spacecraft. The interface is located on the spacecraft side (on the top of the heat pipes)

Project code	Operating (Nominally)		Switch-on	Non-operating	
	Min.	Max.		Min.	Max.
PSM/R3 (SCC)	260 K	280 K	-20 °C	-20 °C	+50°C
PSM/R4 (SCE)	-10 °C	+40 °C	-10 °C	-20 °C	+50°C

Notes:

- 1) Acceptance temperature is 5 0 C below min. and 5 0 C above max operating, non-operating and switch on temperature. Qualification temperature is 10 0 C below min and 10 0 C above max operating, non-operating and switch on temperature.
- 2) Operating temperature range requirement is relevant only when a bed is absorbing (see 4.4.1.1)
- 3) The temperature gradient between the SCC and its spacecraft interfaces shall be lower than 2K for absorbing beds only.
- 4) The temperature gradient between the SCE and the Spacecraft shall be lower than 2K.

4.3.2. On Planck P/L Module (PPLM)

4.3.2.1. Planck module «Cold»

The table below shows the required temperatures at the interface of the Sorption Cooler Piping with the "V" grooves on the platform.



Project code	Operating (Nominally)		Start-up K	Non-operating	
	Min. K	Max. K		Min. K	Max. °C
Warmest V-Groove	150	170	N/A	150	+50
Intermediate V-Groove	100	120	N/A	100	+50
Coldest V-Groove	45	60	60 (1)	40	+50

Notes:

(1) Precooler 3C shall be at temperature < 60K before the SCS to be switched on
- the PACE sensors can be switched on at ambient temperature and pressure for 5 minutes maximum

4.3.2.2. Interface temperatures at the HFI/LFI FPU

Below are given the temperature interface data at the interface to the HFI/LFI focal plane unit.

Project code	Operating (Nominally)		Start-up Max. K	Non-operating	
	Min. K	Max. K		Min. K	Max. °C
PSM/R1 at LVHX2 (LFI)	17.5	22.5	N/A	17.5	+50
PSM/R1 at LVHX1 (HFI)	17.5	19.02	N/A	17.5	+50

Note: this interface is not an interface with the spacecraft for the Flight Model

4.3.3. Temperature channels

The table below shows information relevant to the measurement of instrument temperatures. The column «Power» indicates whether the relevant channel is part of the instrument HK or of the S/C HK. In the latter case temperature information would also be available when the instrument is in its OFF state.



Unit	Power		Location & Acronym	Sensor Type	Temp. (°K)		TM Ref.
	S/C	Instr.			Min	Max	
PSM/R1		x	SCCE-HFI Interface	Thermometer	17	24	
		x	SCCE-LFI Interface	Thermometer	17	24	
PSM/R2	x		PACE - Coldest Shield	Thermometer	40	70	
		x	PACE - Coldest Shield	Thermometer	40	70	
	x		PACE – Intermed. Shield	Thermometer	80	150	
		x	PACE – Intermed. Shield	Thermometer	80	150	
	x		PACE – Warmest Shield	Thermometer	140	190	
		x	PACE – Warmest Shield	Thermometer	140	190	
PSM/R3		x	SCC Radiator		220	350	
PSM/R4		x	SCE		250	350	

Additional temperatures are sampled and used internally by the SCS for operational control, but are not ordinarily available in the housekeeping data stream.

4.4. POWER Interfaces

4.4.1. On SVM

When the SCS is operating with the coldest V-groove shield at a temperature of 60K, the SCC thermal dissipation to the radiator will be as shown in Table 4-1.

Interface	Average Load Max. (W)	Total Peak Load Max. (W)	Single element peak load max (W)
SCE	110		
SCC	470	1200	1020

Table 4-1 Thermal Load on the Radiator

The time variation of the total SCC thermal dissipation to the radiator is shown in Figure 4-2. The major periodic portion of this power is rejected by the cooling compressor element as shown in Figure 4-3. The heat load is imposed at the surface under each of the six individual compressor elements in turn during the ‘cooling’ phase of operation. This happens in the sequence described in Chapter 3. Referring to Figure 4-3, the heat load appears in sequence at compressor elements **5-6-1-2-3-4** of the operating cooler.



The maximum peak loads (total SCC and single element) shall be lower to the figures in the above table using the following hypothesis:

- ▶ contact conductance between S/C and SCC = 10000 W/K/m²
- ▶ single element contact area = 5.08 x 37.5 = 190.5 cm² (5.08 = single element base plate width, 37.5 = single element base plate length)

The thermal model of the SCC is given in IIDB SCS.

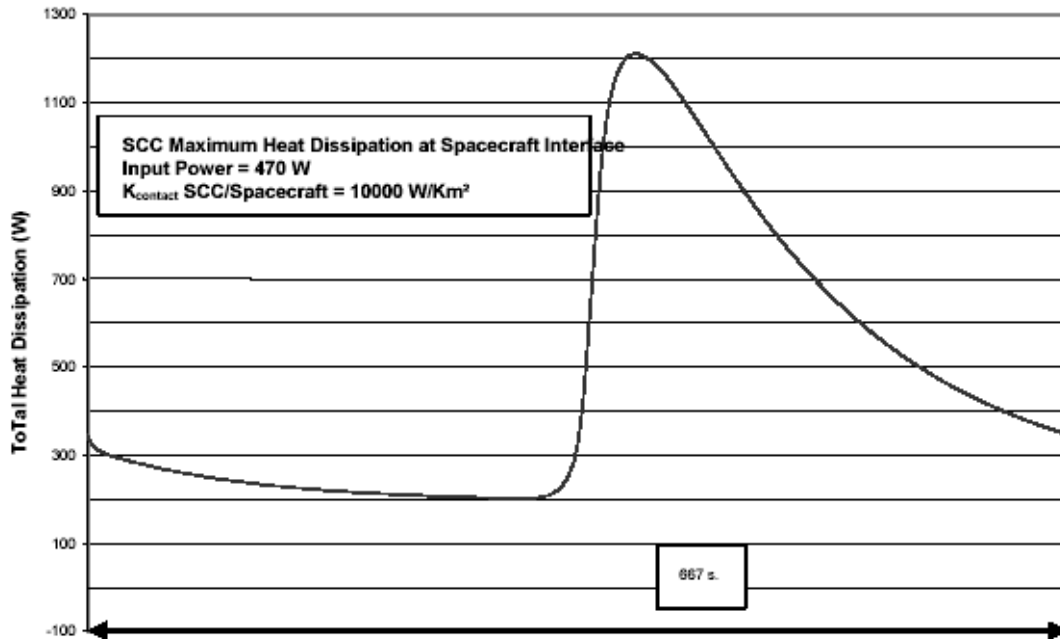

Figure 4-2 Variation of the total heat loading at the Warm Radiator I/F

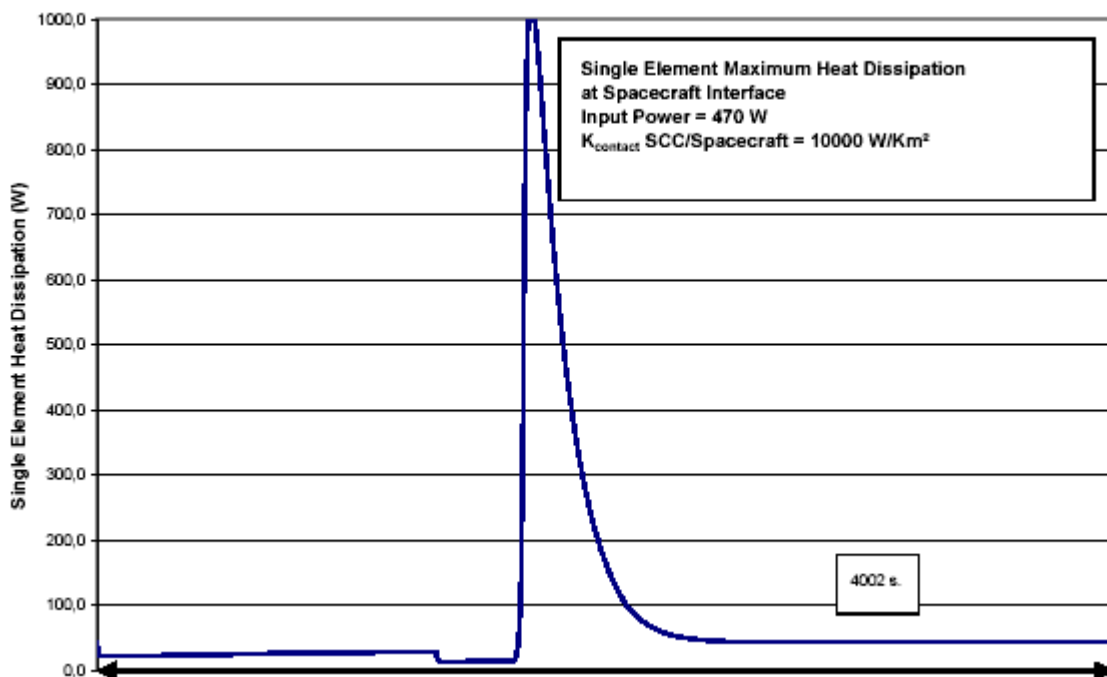

Figure 4-3 Variation of a single bed heat loading at Warm Radiator I/F

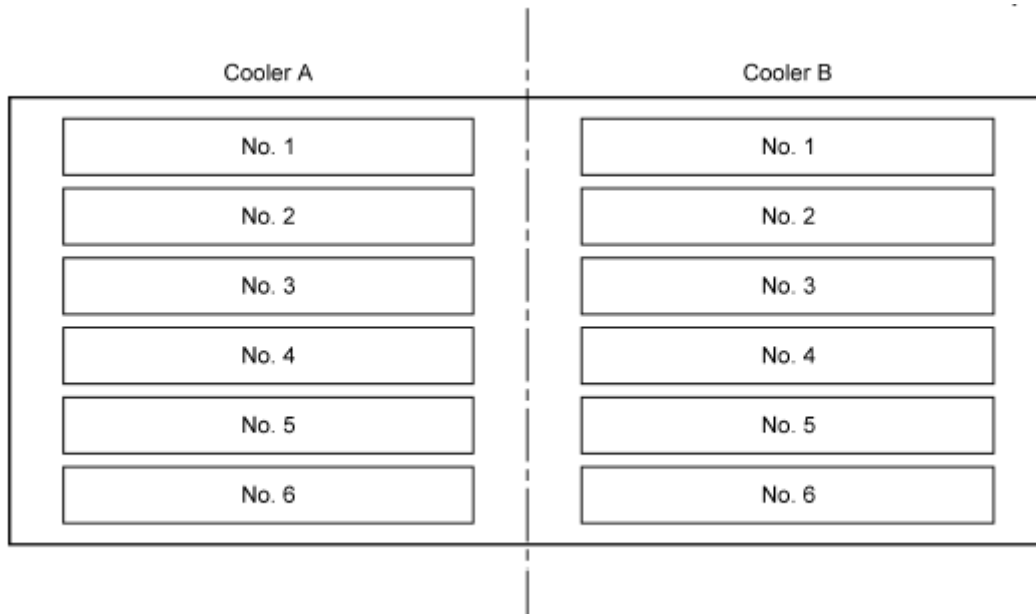

Figure 4-4 SCC Compressor Element Footprints on the Radiator

4.4.1.1. Radiator Temperature Stability

The TMU shall meet its temperature stability requirements at LVHX1 and LVHX2+TSA when the SCC radiator temperature fluctuation (max.–min.) at the SCC side of the interface (with a period equal to the CE phase interval defined earlier and following the cycle shown in table below) does not exceed the following values at the three absorbing compressor elements:

- 6 K at the absorbing CE one CE Phase Interval ahead of the cooling CE
- 2 K at the absorbing CE two CE Phase Intervals ahead of the cooling CE
- 1 K at the absorbing CE three CE Phase Intervals ahead of the cooling CE

For example, at a time when elements 1, 2 and 3 are heating, desorbing and cooling, at the same time elements 4, 5 and 6 are absorbing and the radiator interface temperature stability requirement will be applicable to elements 4, 5 and 6 at levels of 6 K, 2 K and 1 K, respectively. The relative physical locations of the 6 contiguous elements are as shown in table below.

Element	Phase
1	<i>heat</i>
2	<i>desorb</i>
3	<i>cool</i>
4	<i>absorb</i>
5	<i>absorb</i>
6	<i>absorb</i>

Of course, the element operation sequence is cyclic, and the spatial location of the cooling element and adjacent elements will shift with the cycle period.

The assumptions taken on the radiator temperature stability to evaluate the temperature stability at HFI and LFI cold end interfaces were optimistic with respect to the actual radiator design.



Anyway, from the first analysis of the PFM1 test results (see Table 4-2, Figure 4-5 and Figure 4-6) the impact on HFI and LFI temperature oscillations seems to be negligible. This has to be confirmed by a more detailed data analysis and by the next PFM2 test campaign.

Case	Ti (K)	Input P (W)	Tf average (K)	Tf low (K)	Average ΔT (K) across beds		
					1st	2nd	3rd
Cold Thermal Balance	262	298	270.5	268.3	5.18	4.57	4.08
Reference	282	388	282.6	280.1	5.95	4.93	3.67
Hot Thermal Balance	282	470	277.0	274.3	5.37	4.57	3.57

Table 4-2 PFM1 Test Warm Radiator stability on CE's interface side

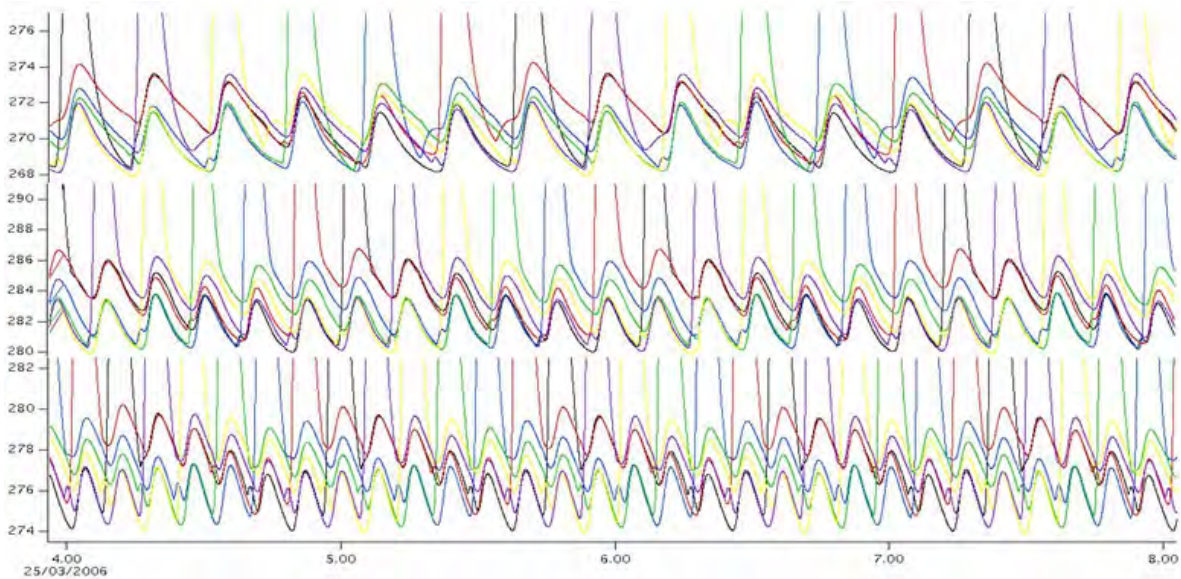

Figure 4-5 PFM1 Test Warm Radiator T oscillations on SCS beds side of I/F in the three test cases: Cold 262-45 (top), Reference 282-60 (mid), Hot 282-60 (bottom)

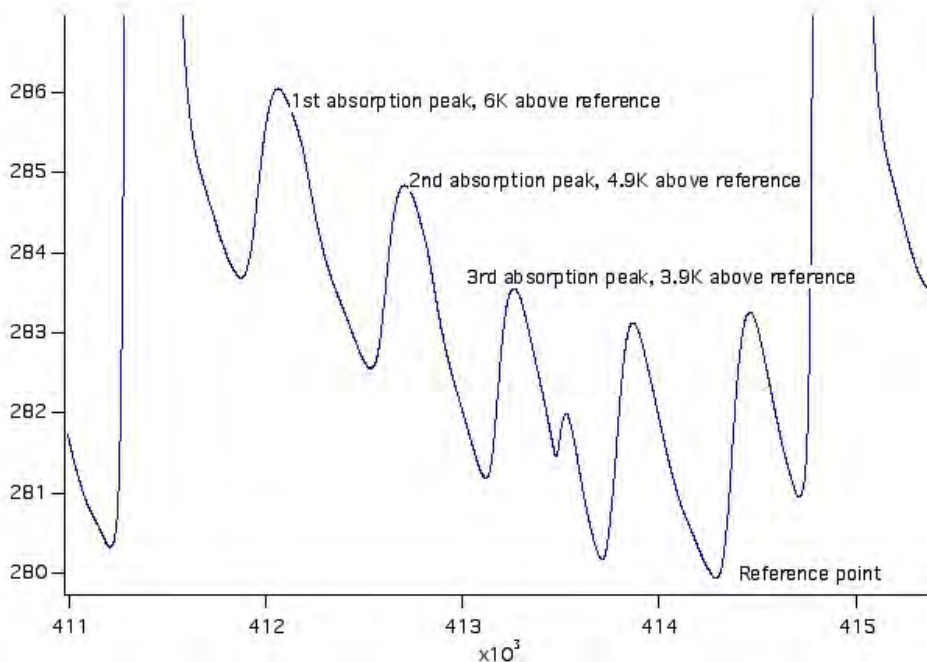

Figure 4-6 PFM1 Test typical single bed T oscillations during absorption



4.4.2. On Planck Module (PPLM)

The reference temperature set on the V-grooves to compute the heat loads is given (from IID-A, with SCC at 280K) by

<i>Design temperatures:</i>	<i>3rd V-Groove</i>	<i>2nd V-Groove</i>	<i>1st V-groove</i>
LFI	52	106	166
HFI	50	110	165
SCS	52	108	158

The allocated heat load at these temperatures are:

Project code	Instrument location	Heat load at reference temperature (mW)	Allocation (IID-A) (mW)
PSM/R2	PACE input to coldest V-groove (PC3A=58.5K, PC3B=56.3K, PC3C=52.3K)	1185	1175
PSM/R2	PACE input to intermediate V-Groove (PC2=108K)	307	447
PSM/R2	PACE input to warmest V-Groove (PC1=158K)	345	566

4.4.3. Supply Voltages

The power load on the 28V main-bus for the Sorption Cooler Subsystem is as follows: separate power lines are required from the spacecraft power subsystem to the SCE for the power to the SCE itself, and the power supplied through the SCE to the SCC. Thus two LCL's are required for each SCE making a total of four in all.

Operating mode	1 st Line BOL (W)	2 nd Line BOL (W)	1 st Line EOL (W)	2 nd Line EOL (W)	Both lines Peak (W)
BOOT & INIT Modes	110	0	100	0	16
READY & RUN Modes	110	426	100	470	64

Notes:

- The total load on main bus for the nominal or redundant SCE shall be inferior to 570 W at a given operating point
- The difference between the power consumption of the SCC BOL to EOL is due to the expected degradation in the beds of the SCC.
- It is assumed that inside the PCDU each line contains ON/OFF switching and current limiters.



4.5. CONNECTOR, HARNESS & GROUNDING

The harness of the SCS consists of the following:

- Harness from SCE to SCCE
- Harness from SCE to SCC

The harness is separate for both the nominal and redundant SCS.

The harnesses from the SCS FM's to both the spacecraft power and communications buses are supplied by ESA.

Harness SCE to SCCE

The SCE to SCCE harness is separated in 2 parts:

- ▶ SCE to subplatform bracket at 300K (PSM5D/PSR5D)
- ▶ Subplatform bracket to charcoal filter bracket at 50K (PSM5C/PSR5C)

The remaining part from the charcoal filter bracket at 50K to the SCCE is part of the PACE.

Harness SCE to SCC

The harness from SCE to SCC is made of 2 cable bundles. One bundle of 8 cables representing 72 twisted pairs of wires (PSM5B/PSR5B) and one bundle of 2 cables representing 13 twisted pairs of wires (PSM5A/PSR5A).

4.5.1. Connectors list (on equipment side)

Pictures of the SCE Connectors are shown in Figure 4-7 and Figure 4-8.
Selection of connectors and pin function allocation will be according to ESA standards.



Connector list on SCE

Ref. Connector	Type	Description
PSM4/PSR4-J01	Pin	Micro-D 37
PSM4/PSR4-J02	Pin	Micro-D 37
PSM4/PSR4-J03	Socket	Sub-D 25
PSM4/PSR4-J04	Socket	Circ. 29, flange
PSM4/PSR4-J06	Socket	Sub-D 37
PSM4/PSR4-J07	Socket	Sub-D 37
PSM4/PSR4-J08	Socket	Sub-D 37
PSM4/PSR4-J09	Socket	Sub-D 15
PSM4/PSR4-J10	Socket	Sub-D 15
PSM4/PSR4-J21	Socket	Sub-D 9,
PSM4/PSR4-J22	Socket	Sub-D 9,
PSM4/PSR4-J23	Pin	Sub-D 9
PSM4/PSR4-J24	Pin	Circ. 8, flange
PSM4/PSR4-J25	Socket	Sub-D 9

Connector list on SCC

Ref. Connector	Type	Description
PSM3/PSR3-J01	Pin	DBMA-25P-NMC-77
PSM3/PSR3-J02	Pin	DAMA-15P-NMC-77
PSM3/PSR3-J03	Pin	MS27497T24F29P
PSM3/PSR3-J05	Socket	DAMA-15S-NMC-77
PSM3/PSR3-J06	Pin	DCMA-37P-NMC-77
PSM3/PSR3-J07		M24308/4-13
PSM3/PSR3-J08		M24308/4-12



Figure 4-7 Front Panel Connectors

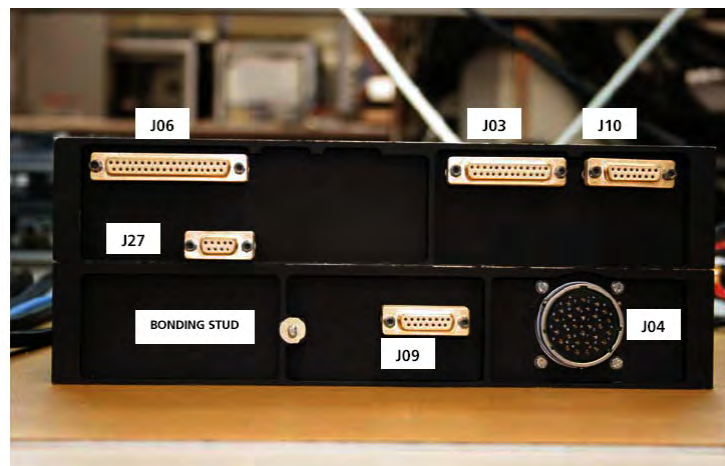

Figure 4-8 Back Panel Connectors

4.5.2. Harness

The interconnection diagram of the Sorption Cooler Subsystem is given below in Figure 4-9.

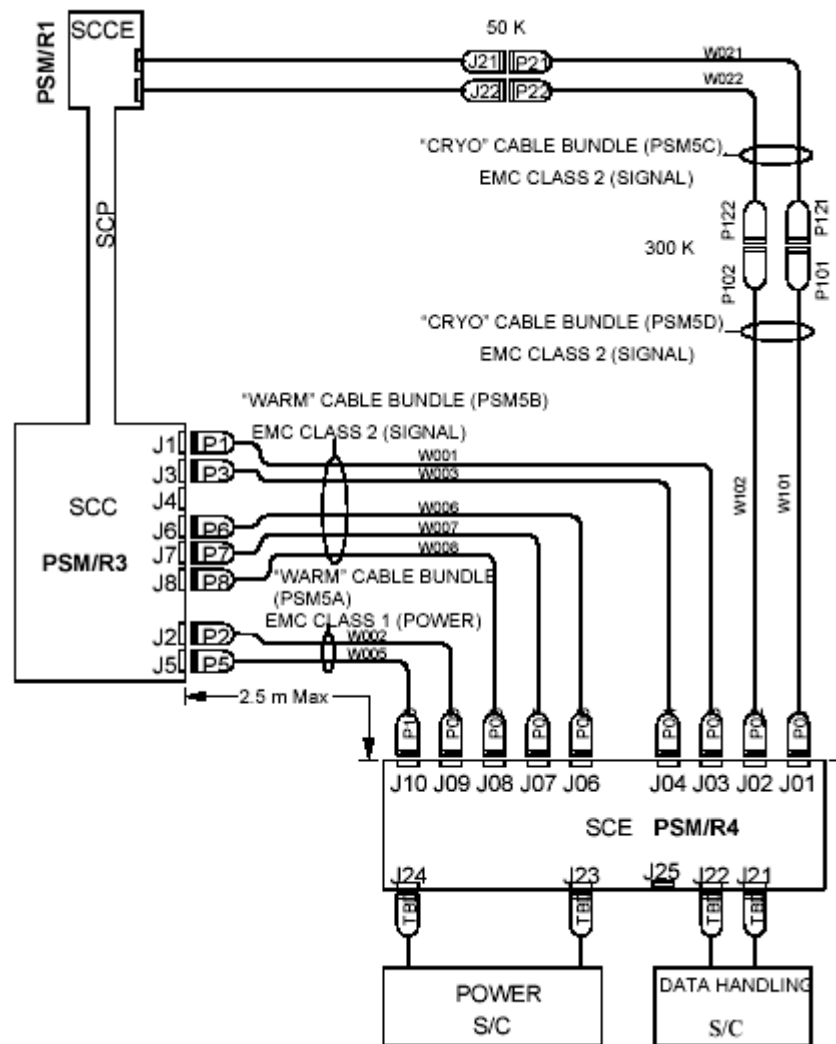

Figure 4-9 SCS interconnection harness diagram

Notes:

- 1) Cable harnesses for the Nominal and Redundant sorption coolers are identical. Only a single sorption cooler is shown.
- 2) Redundant sorption cooler uses PSR5 A/B/C cables bundles.
- 3) Nominal and redundant cables shall be routed separately.
- 4) The cryo-harness from the PSM/R3 to the precoolers on the V-Grooves is not apparent on the figure. It will be delivered attached to the pipes

4.5.2.1. SCS - S/C Harness

The S/C harness provides the interconnection between the Sorption Cooler Electronics and the S/C Power subsystem (see Figure 4-9, J23 & J24) and the S/C Data Handling subsystem (J21 & J22).

On the instrument side, pin functions are given below in this section.



4.5.2.1.1. Communication bus (1553B) and On Board Clock Synch

J21 carries the nominal (A) MIL STD 1553 Bus and the On Board Clock Signal from the CDMS.

Pin No.	Function
1	Grounded
2	Tx/Rx A+
3	Grounded
4	Grounded
5	OBC +
6	TX/RX A-
7	Grounded
8	Grounded
9	OBC -

J22 carries the redundant (B) MIL STD 1553 Bus only

Pin No.	Function
1	Grounded
2	Tx/Rx B+
3	Grounded
4	Grounded
5	Grounded
6	TX/RX B-
7	Grounded
8	Grounded
9	Grounded

4.5.2.1.2. Power Supply pin out connectors:

J23, 1st power supply line from the spacecraft, 28V 5A.



Pin No.	Function
1	No Connection
2	Primary Power 28 Volts
3	Primary Power 28 Volts Return
4	No Connection
5	No Connection
6	Primary Power 28 Volts Return
7	Primary Power 28 Volts
8	No Connection
9	No Connection

J24, 2nd power supply line from the spacecraft, 28V 20A.

Pin No.	Function
A	Primary Power 28 Volts
B	Primary Power 28 Volts
C	Primary Power 28 Volts
D	Primary Power 28 Volts Return
E	Primary Power 28 Volts
F	Primary Power 28 Volts Return
G	Primary Power 28 Volts Return
H	Primary Power 28 Volts Return

4.5.2.1.3. SCE 1553B address connector

J25, SCE 1553B address connector

Pin No.	Function
1	RT-AD4
2	RT-AD3
3	RT-AD2
4	RT-AD1
5	RT-AD0
6	RT-PAR
7	Grounded
8	Grounded
9	Grounded



4.5.2.2. Sorption Cooler Subsystem Harness

4.5.2.2.1. Sorption Cooler Subsystem Harness on SVM

The SCS warm harness runs from the SCE to the SCC. Pin functions and wiring characteristics are given below.

Wire type is given in 5.10.2.2.4



Cable PSM5B/PSR5B W001, Precoolers Temperature Sensors

- ▶ SCE End: Connector PSM/R4-P03
- ▶ SCC End: Connector PSM/R3-P01

Pin No.	Function	EMC Class*	Wire Type**	EMF _{NOM} (V)	I _{MAX} (A)	Size (AWG)	Pin No.
1	PC1 Temp T12 Excitation +	2	A	28	0.001	26	1
2	PC1 Temp T12 Signal +	2	A	0.4		26	2
3	PC3B Temp T09 Excitation +	2	A	28	0.001	26	3
4	PC3B Temp T09 Signal +	2	A	0.4		26	4
5	PC3A Temp T10 Excitation +	2	A	28	0.001	26	5
6	PC3A Temp T10 Signal +	2	A	0.4		26	6
7	PC3C Temp T08 Excitation +	2	A	28	0.001	26	7
8	PC3C Temp T08 Signal +	2	A	0.4		26	8
9	PC2 Temp T11 Excitation +	2	A	28	0.001	26	9
10	PC2 Temp T11 Signal +	2	A	0.4		26	10
11	Spare (Grounded)						11
12	Spare (Grounded)						12
13	Spare (Grounded)						13
14	PC1 Temp T12 Excitation -	2	A	28	0.001	26	14
15	PC1 Temp T12 Signal -	2	A	0.4		26	15
16	PC3B Temp T09 Excitation -	2	A	28	0.001	26	16
17	PC3B Temp T09 Signal -	2	A	0.4		26	17
18	PC3A Temp T10 Excitation -	2	A	28	0.001	26	18
19	PC3A Temp T10 Signal -	2	A	0.4		26	19
20	PC3C Temp T08 Excitation -	2	A	28	0.001	26	20
21	PC3C Temp T08 Signal -	2	A	0.4		26	21
22	PC2 Temp T11 Excitation -	2	A	28	0.001	26	22
23	PC2 Temp T11 Signal -	2	A	0.4		26	23
24	Spare (Grounded)						24
25	Spare (Grounded)						25

Notes:

* EMC Classes 1-Power, 2-Signal [Per IIDA, 5.14.2.1].

** Wire type is described below



Cable PSM5A/PSR5A W002, SCC Low Power Heaters

- ▶ At SCE End: Connector PSM/R4-P09
- ▶ At SCC End: Connector PSM/R3-P02

Pin No.	Function	EMC Class [*]	Wire Type [*]	EMF _{NOM} (V)	I _{MAX} (A)	Size (AWG)	Pin No.
1	CE1 Heat Sw Heater 21A	1	AA	12	0.93	20	1
2	CE1 Heat Sw Heater 21B	1	AA	12	0.93	20	2
3	CE2 Heat Sw Heater 22A	1	AA	12	0.93	20	3
4	CE2 Heat Sw Heater 22B	1	AA	12	0.93	20	4
5	CE3 Heat Sw Heater 23A	1	AA	12	0.93	20	5
6	CE3 Heat Sw Heater 23B	1	AA	12	0.93	20	6
7	CE4 Heat Sw Heater 24A	1	AA	12	0.93	20	7
8	CE4 Heat Sw Heater 24B	1	AA	12	0.93	20	8
9	CE5 Heat Sw Heater 25A	1	AA	12	0.93	20	9
10	CE5 Heat Sw Heater 25B	1	AA	12	0.93	20	10
11	CE6 Heat Sw Heater 26A	1	AA	12	0.93	20	11
12	CE6 Heat Sw Heater 26B	1	AA	12	0.93	20	12
13	LPSB Heater 07A	1	AA	12	0.27	20	13
14	LPSB Heater 07B	1	AA	12	0.27	20	14
15	Spare (Grounded)						15

Notes:

* EMC Classes 1-Power, 2-Signal [Per IIDA, 5.14.2.1].

** Wire type is described below



Cable PSM5B/PSR5B W003, SCC High Power Heaters

- ▶ At SCE End: Connector: PSM/R4-P04
- ▶ At SCC End: Connector PSM/R3-P03

Pin No.	Function	EMC Class *	Wire Type*	EMF _{NOM} (V)	I _{MAX} (A)	Size (AWG)	Pin No .
A	LPSB Heater H08A	1	B	28	1.43	16	A
B	LPSB Heater H08B	1	B	28	1.43	16	B
C	CE1 Heater H01A	2	B	28	5.15	16	C
D	CE1 Heater H01B	2	B	28	5.15	16	D
E	CE1 Heater H11A	2	B	28	6.78	16	E
F	CE1 Heater H11B	2	B	28	6.78	16	F
G	CE2 Heater H02A	2	B	28	5.15	16	G
H	CE2 Heater H02B	2	B	28	5.15	16	H
J	CE2 Heater H12A	2	B	28	6.78	16	J
K	CE2 Heater H12B	2	B	28	6.78	16	K
L	CE3 Heater H03A	2	B	28	5.15	16	L
M	CE3 Heater H03B	2	B	28	5.15	16	M
N	CE3 Heater H13A	2	B	28	6.78	16	N
P	CE3 Heater H13B	2	B	28	6.78	16	P
R	CE4 Heater H04A	2	B	28	5.15	16	R
S	CE4 Heater H04B	2	B	28	5.15	16	S
T	CE4 Heater H14A	2	B	28	6.78	16	T
U	CE4 Heater H14B	2	B	28	6.78	16	U
V	CE5 Heater H05A	2	B	28	5.15	16	V
W	CE5 Heater H05B	2	B	28	5.15	16	W
X	CE5 Heater H15A	2	B	28	6.78	16	X
Y	CE5 Heater H15B	2	B	28	6.78	16	Y
Z	CE6 Heater H06A	2	B	28	5.15	16	Z
a	CE6 Heater H06B	2	B	28	5.15	16	a
b	CE6 Heater H16A	2	B	28	6.78	16	b
c	CE6 Heater H16B	2	B	28	6.78	16	c
d	Spare (Grounded)						d
e	Spare (Grounded)						e
f	Spare (Grounded)						f

Notes:



* EMC Classes 1-Power, 2-Signal [Per IIDA, 5.14.2.1].

** Wire type is described below

Cable PSM5A/PSR5A W005, CE internal Temperature Sensors

- ▶ At SCE End: Connector PSM/R4-P10
- ▶ At SCC End: Connector PSM/R3-P05

Pin No.	Function	EMC Class*	Wire Type**	EMF _{NOM} (V)	I _{MAX} (A)	Size (AWG)	Pin No.
1	CE1 TC T20+	1	A	0.02		26	1
2	CE2 TC T21+	1	A	0.02		26	2
3	CE3 TC T22+	1	A	0.02		26	3
4	CE4 TC T23+	1	A	0.02		26	4
5	CE5 TC T24+	1	A	0.02		26	5
6	CE6 TC T25+	1	A	0.02		26	6
7	Spare (Grounded)						7
8	Spare (Grounded)						8
9	CE1 TC T20-	1	A	0.02		26	9
10	CE2 TC T21-	1	A	0.02		26	10
11	CE3 TC T22-	1	A	0.02		26	11
12	CE4 TC T23-	1	A	0.02		26	12
13	CE5 TC T24-	1	A	0.02		26	13
14	CE6 TC T25-	1	A	0.02		26	14
15	Spare (Grounded)						15

Notes:

* EMC Classes 1-Power, 2-Signal [Per IIDA, 5.14.2.1].

** Wire type is described below



Cable PSM5B/PSR5B W006, SCC Temperature Sensors

- ▶ At SCE End: Connector: PSM/R4-P06
- ▶ At SCC End: Connector PSM/R3-P06

Pin No.	Function	EMC Class*	Wire Type**	EMF _{NOM} (Volts)	I _{MAX} (A)	Size (AWG)	Pin No.
1	LPSB Temp T17 Excitation +	2	A	28	0.01	26	1
2	LPSB Temp T17 Signal +	2	A	0.1		26	2
3	LPSB Temp T18 Excitation +	2	A	28	0.01	26	3
4	LPSB Temp T18 Signal +	2	A	0.1		26	4
5	Spare (Grounded)						5
6	Spare (Grounded)						6
7	CE1 Temp T15 Excitation +	2	A	28	0.01	26	7
8	CE1 Temp T15 Signal +	2	A	0.1		26	8
9	CE2 Temp T16 Excitation +	2	A	28	0.01	26	9
10	CE2 Temp T16 Signal +	2	A	0.1		26	10
11	HPST Temp T13 Excitation +	2	A	28	0.01	26	11
12	HPST Temp T13 Signal +	2	A	0.1		26	12
13	HPST Temp T14 Excitation +	2	A	28	0.01	26	13
14	HPST Temp T14 Signal +	2	A	0.1		26	14
15	Spare (Grounded)						15
16	Spare (Grounded)						16
17	Spare (Grounded)						17
18	Spare (Grounded)						18
19	Spare (Grounded)						19
20	LPSB Temp T17 Excitation -	2	A	28	0.01	26	20
21	LPSB Temp T17 Signal -	2	A	0.1		26	21
22	LPSB Temp T18 Excitation -	2	A	28	0.01	26	22
23	Spare (Grounded)						23
24	Spare (Grounded)						24
25	LPSB Temp T19 Signal -	2	A	0.1		26	25
26	CE1 Temp T15 Excitation -	2	A	28	0.01	26	26
27	CE1 Temp T15 Signal -	2	A	0.1		26	27
28	CE2 Temp T16 Excitation -	2	A	28	0.01	26	28
29	CE2 Temp T16 Signal -	2	A	0.1		26	29
30	HPST Temp T13 Excitation -	2	A	28	0.01	26	30
31	HPST Temp T13 Signal -	2	A	0.1		26	31
32	HPST Temp T14 Excitation -	2	A	28	0.01	26	32
33	HPST Temp T14 Signal -	2	A	0.1		26	33
34	Spare (Grounded)						34
35	Spare (Grounded)						35
36	Spare (Grounded)						36
37	Spare (Grounded)						37

Notes:

* EMC Classes 1-Power, 2-Signal [Per IIDA, 5.14.2.1].

** Wire type is described below



Cable PSM5B/PSR5B W007, CE Pressure Transducers

- ▶ At SCE End: Connector: PSM/R4-P07
- ▶ At SCC End: Connector PSM/R3-P07

Pin No.	Function	EMC Class*	Wire Type*	EMF _{NOM} (V)	I _{MAX} (mA)	Size (AWG)	Pin No.
1	CE1 Pres P01A Excitation +	2	A	28	0.04	26	1
2	CE1 Pres P01B Signal +	2	A	0-10		26	2
3	CE2 Pres P02A Excitation +	2	A	28	0.04	26	3
4	CE2 Pres P02B Signal +	2	A	0-10		26	4
5	CE3 Pres P03A Excitation +	2	A	28	0.04	26	5
6	CE3 Pres P03B Signal +	2	A	0-10		26	6
7	CE4 Pres P04A Excitation +	2	A	28	0.04	26	7
8	CE4 Pres P04B Signal +	2	A	0-10		26	8
9	CE5 Pres P05A Excitation +	2	A	28	0.04	26	9
10	CE5 Pres P05B Signal +	2	A	0-10		26	10
11	CE6 Pres P06A Excitation +	2	A	28	0.04	26	11
12	CE6 Pres P06B Signal +	2	A	0-10		26	12
13	Spare (Grounded)						13
14	Spare (Grounded)						14
15	Spare (Grounded)						15
16	Spare (Grounded)						
17	Spare (Grounded)						
18	Spare (Grounded)						
19	Spare (Grounded)						
20	CE1 Pres P01D Excitation -	2	A	28	0.04	26	16
21	CE1 Pres P01C Signal -	2	A	0-10		26	17
22	CE2 Pres P02D Excitation -	2	A	28	0.04	26	18
23	CE2 Pres P02C Signal -	2	A	0-10		26	19
24	CE3 Pres P03D Excitation -	2	A	28	0.04	26	20
25	CE3 Pres P03C Signal -	2	A	0-10		26	21
26	CE4 Pres P04D Excitation -	2	A	28	0.04	26	22
27	CE4 Pres P04C Signal -	2	A	0-10		26	23
28	CE5 Pres P05D Excitation -	2	A	28	0.04	26	24
29	CE5 Pres P05C Signal -	2	A	0-10		26	25
30	CE6 Pres P06D Excitation -	2	A	28	0.04	26	26
31	CE6 Pres P06C Signal -	2	A	0-10		26	27
32	Spare (Grounded)						
33	Spare (Grounded)						
34	Spare (Grounded)						
35	Spare (Grounded)						
36	Spare (Grounded)						
37	Spare (Grounded)						

Notes:

* EMC Classes 1-Power, 2-Signal [Per IIDA, 5.14.2.1].

** Wire type is described below



Cable PSM5B/PSR5B W008, SCC Pressure and Temperature Sensors

- ▶ At SCE End: Connector PSM/R4-P08
- ▶ At SCC End: Connector PSM/R3-P08

Pin No.	Function	EMC Class*	Wire Type*	EMF _{NOM} (V)	I _{MAX} (A)	Size (AWG)	Pin No.
1	HP Pres P07A Excitation +	2	A	28	0.04	26	1
2	HP Pres P07B Signal +	2	A	0-10		26	2
3	LP Pres P08A Excitation +	2	A	28	0.04	26	3
4	LP Pres P08B Signal +	2	A	0-10		26	4
5	CE3 Temp T26 Excitation +	2	A	28	10 ⁻³	26	5
6	CE3 Temp T26 Signal +	2	A	0.1		26	6
7	CE4 Temp T27 Excitation +	2	A	28	10 ⁻³	26	7
8	CE4 Temp T27 Signal +	2	A	0.1		26	8
9	CE5 Temp T28 Excitation +	2	A	28	10 ⁻³	26	9
10	CE5 Temp T28 Signal +	2	A	0.1		26	19
11	CE6 Temp T29 Excitation +	2	A	28	10 ⁻³	26	21
12	CE6 Temp T29 Signal +	2	A	0.1		26	23
13	Spare (Grounded)						25
14	Spare (Grounded)						26
15	Spare (Grounded)						
16	Spare (Grounded)						
17	Spare (Grounded)						
18	Spare (Grounded)						
19	Spare (Grounded)						
20	HP Pres P07D Excitation -	2	A	28	0.04	26	10
21	HP Pres P07C Signal -	2	A	0-10		26	11
22	LP Pres P08D Excitation -	2	A	28	0.04	26	12
23	LP Pres P08C Signal -	2	A	0-10		26	13
24	CE3 Temp T26 Excitation -	2	A	28	10 ⁻³	26	14
25	CE3 Temp T26 Signal -	2	A	0.1		26	15
26	CE4 Temp T27 Excitation -	2	A	28	10 ⁻³	26	16
27	CE4 Temp T27 Signal -	2	A	0.1		26	17
28	CE5 Temp T28 Excitation -	2	A	28	10 ⁻³	26	18
29	CE5 Temp T28 Signal -	2	A	0.1		26	20
30	CE6 Temp T29 Excitation -	2	A	28	10 ⁻³	26	22
31	CE6 Temp T29 Signal -	2	A	0.1		26	24
32	Spare (Grounded)						
33	Spare (Grounded)						
34	Spare (Grounded)						
35	Spare (Grounded)						
36	Spare (Grounded)						
37	Spare (Grounded)						

Notes:

* EMC Classes 1-Power, 2-Signal [Per IIDA, 5.14.2.1].

** Wire type is described below



4.5.2.2.2. Cryo Harness

The SCS cryo harness runs from the SCE to the SCCE. It is interrupted by two brackets : one on the sub-platform at 300K, and one on the charcoal filter at 50K on groove 3. Pin functions and wiring characteristics are given below.



Cable PSM5C/PSR5C W021, Temperature Sensors

- ▶ At 300K end: Connector: PSM/R5C-P121
- ▶ At 50K end: Connector PSM/R5C-P21

Pin No.	Function	EMC Class*	Wire Type**	EMF _{NOM} (V)	I _{MAX} (A)	Size (AWG)	Pin No.
1	LR1 Temp T01 Excitation +	2	C	28	10 ⁻⁵	38	1
2	LR1 Temp T01 Signal +	2	C	0.4	5*10 ⁻⁸	38	2
3	LR1 Temp T02 Excitation +	2	C	28	10 ⁻⁵	38	3
4	LR1 Temp T02 Signal +	2	C	0.4	5*10 ⁻⁸	38	4
5	LR2 Temp T03 Excitation +	2	C	28	10 ⁻⁵	38	5
6	LR2 Temp T03 Signal +	2	C	0.4	5*10 ⁻⁸	38	6
7	LR2 Temp T04 Excitation +	2	C	28	10 ⁻⁵	38	7
8	LR2 Temp T04 Signal +	2	C	0.4	5*10 ⁻⁸	38	8
9	LR3 Temp T05 Excitation +	2	C	28	10 ⁻⁵	38	9
10	LR3 Temp T05 Signal +	2	C	0.4	5*10 ⁻⁸	38	10
11	JT Temp T30 Excitation +	2	C	28	10 ⁻⁵	38	11
12	LR3 Temp T06 Signal +	2	C	0.4	5*10 ⁻⁸	38	12
13	JT Temp T30 Signal +	2	C	0.4	5*10 ⁻⁸	38	13
14	JT Temp T07 Signal +	2	C	0.4	5*10 ⁻⁸	38	14
15	LR3 Heater H31A Voltage	2	C	31	0	38	15
16	LR3 Heater H32A Voltage	2	C	31	0	38	16
17	JT Temp T07 Excitation +	2	C	0.4	10 ⁻⁵	38	17
18	LR3 Temp T06 Excitation +	2	C	0.4	10 ⁻⁵	38	18
19	Spare (Grounded)						19
20	LR1 Temp T01 Excitation -	2	C	28	10 ⁻⁵	38	20
21	LR1 Temp T01 Signal -	2	C	0.4	5*10 ⁻⁸	38	21
22	LR1 Temp T02 Excitation -	2	C	28	10 ⁻⁵	38	22
23	LR1 Temp T02 Signal -	2	C	0.4	5*10 ⁻⁸	38	23
24	LR2 Temp T03 Excitation -	2	C	28	10 ⁻⁵	38	24
25	LR2 Temp T03 Signal -	2	C	0.4	5*10 ⁻⁸	38	25
26	LR2 Temp T04 Excitation -	2	C	28	10 ⁻⁵	38	26
27	LR2 Temp T04 Signal -	2	C	0.4	5*10 ⁻⁸	38	27
28	LR3 Temp T05 Excitation -	2	C	28	10 ⁻⁵	38	28
29	LR3 Temp T05 Signal -	2	C	0.4	5*10 ⁻⁸	38	29
30	JT Temp T30 Excitation -	2	C	0.4	10 ⁻⁵	38	30
31	LR3 Temp T06 Signal -	2	C	0.4	5*10 ⁻⁸	38	31
32	JT Temp T30 Signal -	2	C	0.4	5*10 ⁻⁸	38	32
33	JT Temp T07 Signal -	2	C	0.4	5*10 ⁻⁸	38	33
34	LR3 Heater H31B Voltage	2	C	31	0	38	34
35	LR3 Heater H32B Voltage	2	C	31	0	38	35
36	JT Temp T07 Excitation -	2	C	0.4	10 ⁻⁵	38	36
37	LR3 Temp T06 Excitation -	2	C	0.4	10 ⁻⁵	38	37

Notes:

* EMC Classes 1-Power, 2-Signal [Per IIDA, 5.14.2.1].

** TP=Twisted Pair; TPSJ=TP with Shielded Jacket.



Cable PSM5C/PSR5C W022, SCCE Heaters

- ▶ At 300K End: Connector: PSM/R5C-P122
- ▶ At 50K End: Connector PSM/R5C-P22

Pin No.	Function	EMC Class*	Wire Type**	EMF _{NOM} (V)	I _{MAX} (mA)	Size (AWG)	Pin No.
1	LR3 Heater H31A	2	D	31	0.035	38	1
2	LR3 Heater H32A	2	D	31	0.035	38	2
3	F9 Heater H33A	1	E	28	0.145	32	3
4	JT Heater H34A	1	E	28	0.145	32	4
5	Spare (Grounded)						5
6	LR3 Heater H31B	2	D	31	0.035	38	6
7	LR3 Heater H32B	2	D	31	0.035	38	7
8	F9 Heater H33B	1	E	28	0.145	32	8
9	JT Heater H34B	1	E	28	0.145	32	9
10	Spare (Grounded)						10
11	F9 Heater H36A	1	E	28	0.145	32	11
12	JT Heater H35A	1	E	28	0.145	32	12
13	F9 Heater H36B	1	E	28	0.145	32	13
14	JT Heater H35B	1	E	28	0.145	32	25
15	Spare (Grounded)						15
16	Spare (Grounded)						16
17	Spare (Grounded)						17
18	Spare (Grounded)						18
19	Spare (Grounded)						19
20	Spare (Grounded)						20
21	Spare (Grounded)						21
22	Spare (Grounded)						22
23	Spare (Grounded)						23
24	Spare (Grounded)						24
25	Spare (Grounded)						14
26	Spare (Grounded)						
27	Spare (Grounded)						
28	Spare (Grounded)						
29	Spare (Grounded)						
30	Spare (Grounded)						
31	Spare (Grounded)						
32	Spare (Grounded)						
33	Spare (Grounded)						
34	Spare (Grounded)						
35	Spare (Grounded)						
36	Spare (Grounded)						
37	Spare (Grounded)						

Notes:

* EMC Classes 1-Power, 2-Signal [Per IIDA, 5.14.2.1].

** TP=Twisted Pair; TPSJ=TP with Shielded Jacket.



Cable PSM/R5D W101 Temperature sensors

- ▶ At SCE End: Connector: PSM/R4-P01
- ▶ At 300K End : Connector PSM/R5D-P101

Pin No.	Function	EMC Class*	Wire Type**	EMF _{NOM} (V)	I _{MAX} (A)	Size (AWG)	Pin No.
1	LR1 Temp T01 Excitation +	2	A	28	10 ⁻⁵	26	1
2	LR1 Temp T01 Signal +	2	A	0.4	5*10 ⁻⁸	26	2
3	LR1 Temp T02 Excitation +	2	A	28	10 ⁻⁵	26	3
4	LR1 Temp T02 Signal +	2	A	0.4	5*10 ⁻⁸	26	4
5	LR2 Temp T03 Excitation +	2	A	28	10 ⁻⁵	26	5
6	LR2 Temp T03 Signal +	2	A	0.4	5*10 ⁻⁸	26	6
7	LR2 Temp T04 Excitation +	2	A	28	10 ⁻⁵	26	7
8	LR2 Temp T04 Signal +	2	A	0.4	5*10 ⁻⁸	26	8
9	LR3 Temp T05 Excitation +	2	A	28	10 ⁻⁵	26	9
10	LR3 Temp T05 Signal +	2	A	0.4	5*10 ⁻⁸	26	10
11	JT Temp T30 Excitation +	2	A	28	10 ⁻⁵	26	11
12	LR3 Temp T06 Signal +	2	A	0.4	5*10 ⁻⁸	26	12
13	JT Temp T30 Signal +	2	A	0.4	5*10 ⁻⁸	26	13
14	JT Temp T07 Signal +	2	A	0.4	5*10 ⁻⁸	26	14
15	Unconnected	2	A	31	0	26	15
16	Unconnected	2	A	31	0	26	16
17	JT Temp T07 Excitation +	2	A	0.4	10 ⁻⁵	26	17
18	LR3 Temp T06 Excitation +	2	A	0.4	10 ⁻⁵	26	18
19	Spare (Grounded)						19
20	LR1 Temp T01 Excitation -	2	A	28	10 ⁻⁵	26	20
21	LR1 Temp T01 Signal -	2	A	0.4	5*10 ⁻⁸	26	21
22	LR1 Temp T02 Excitation -	2	A	28	10 ⁻⁵	26	22
23	LR1 Temp T02 Signal -	2	A	0.4	5*10 ⁻⁸	26	23
24	LR2 Temp T03 Excitation -	2	A	28	10 ⁻⁵	26	24
25	LR2 Temp T03 Signal -	2	A	0.4	5*10 ⁻⁸	26	25
26	LR2 Temp T04 Excitation -	2	A	28	10 ⁻⁵	26	26
27	LR2 Temp T04 Signal -	2	A	0.4	5*10 ⁻⁸	26	27
28	LR3 Temp T05 Excitation -	2	A	28	10 ⁻⁵	26	28
29	LR3 Temp T05 Signal -	2	A	0.4	5*10 ⁻⁸	26	29
30	JT Temp T30 Excitation -	2	A	0.4	10 ⁻⁵	26	30
31	LR3 Temp T06 Signal -	2	A	0.4	5*10 ⁻⁸	26	31
32	JT Temp T30 Signal -	2	A	0.4	5*10 ⁻⁸	26	32
33	JT Temp T07 Signal -	2	A	0.4	5*10 ⁻⁸	26	33
34	Unconnected	2	A	31	0	26	34
35	Unconnected	2	A	31	0	26	35
36	JT Temp T07 Excitation -	2	A	0.4	10 ⁻⁵	26	36
37	LR3 Temp T06 Excitation -	2	A	0.4	10 ⁻⁵	26	37

Notes:

* EMC Classes 1-Power, 2-Signal [Per IIDA, 5.14.2.1].

** TP=Twisted Pair; TPSJ=TP with Shielded Jacket.



Cable PSM/R5C W102 SCCE Heaters

- ▶ At SCE End: Connector PSM/R4-P02
- ▶ At 300K End: Connector PSM/R5D-P102

Pin No.	Function	EMC Class*	Wire Type**	EMF _{NOM} (V)	I _{MAX} (mA)	Size (AWG)	Pin No.
1	LR3 Heater H31A	2	A	31	0.035	26	1
2	LR3 Heater H32A	2	A	31	0.035	26	2
3	F9 Heater H33A	1	A	28	0.145	26	3
4	JT Heater H34A	1	A	28	0.145	26	4
5	Spare (Grounded)						5
6	LR3 Heater H31B	2	A	31	0.035	26	6
7	LR3 Heater H32B	2	A	31	0.035	26	7
8	F9 Heater H33B	1	A	28	0.145	26	8
9	JT Heater H34B	1	A	28	0.145	26	9
10	Spare (Grounded)						10
11	F9 Heater H36A	1	A	28	0.145	26	11
12	JT Heater H35A	1	A	28	0.145	26	12
13	F9 Heater H36B	1	A	28	0.145	26	13
14	JT Heater H35B	1	A	28	0.145	26	14
15	Spare (Grounded)						15
16	Spare (Grounded)						16
17	Spare (Grounded)						17
18	Spare (Grounded)						18
19	Spare (Grounded)						19
20	Spare (Grounded)						20
21	Spare (Grounded)						21
22	Spare (Grounded)						22
23	Spare (Grounded)						23
24	Spare (Grounded)						24
25	Spare (Grounded)						25
26	Spare (Grounded)						26
27	Spare (Grounded)						27
28	Spare (Grounded)						28
29	Spare (Grounded)						29
30	Spare (Grounded)						30
31	Spare (Grounded)						31
32	Spare (Grounded)						32
33	Spare (Grounded)						33
34	Spare (Grounded)						34
35	Spare (Grounded)						35
36	Spare (Grounded)						36
37	Spare (Grounded)						37

Notes:

* EMC Classes 1-Power, 2-Signal [Per IIDA, 5.14.2.1].

** TP=Twisted Pair; TPSJ=TP with Shielded Jacket.



4.5.2.2.3. Connectors reference specifications

Connectors at PSM4/PSR4, SCE end, on harness side.

Name	Type	Description	Reference	Manufact.	Weigh (gr)
P01	Socket	Micro-D, 37 points	MWDM-2L-37SSP-429	Glenair	4.4
		Shell	500T010M37B09		12
P02	Socket	Micro-D, 37 points	MWDM-2L-37SSP-429		4.4
		Shell	500T010M37B09		12
P03	Pin	Sub-D, 25 points	340100201BDBMA25PNMB	FCI	18.1
		Shell	DB8949405-1NM		20
P04	Pin	Circular, 29 points	340104401B06G24-29PN		55.7
		Shell, nut	340106209B		10(TBC)
		Shell, clamp	340106218B		10(TBC)
P06	Pin	Sub-D, 37 points	340100201BDCMA37PNMB		25.6
		Shell	DC8949405-1NM		30
P07	Pin	Sub-D, 37 points	340100201BDCMA37PNMB		25.6
		Shell	DC8949405-1NM		30
P08	Pin	Sub-D, 37 points	340100201BDCMA37PNMB		25.6
		Shell	DC8949405-1NM	30	
P09	Pin	Sub-D, 15 points	340100201BDAMA15PNMB	11	
		Shell	DA8949405-1NM	18	
P10	Pin	Sub-D, 15 points	340100201BDAMA15PNMB	11	
		Shell	DA8949405-1NM	18	



Connectors at PSM3/PSR3, SCC end, on harness side.

Name	Type	Description	Reference	Manufact.	Weigh (gr)	
P01	Socket	Sub-D, 25 points	340100201BDBMA25SNMB	FCI	18.9	
		Shell	DB8949405-1NM		20	
P03	Socket	Circular, 29 points	340104401B06G24-29SN		58.2	
		Shell, nut	340106209B		10(TBC)	
		Shell, clamp	340106218B		10(TBC)	
P06	Socket	Sub-D, 37 points	340100201BDCMA37SNMB		26.7	
		Shell	DC8949405-1NM		30	
P07*	Socket	HTD, 44 points	HTDA-44PTI-FO		CINCH	16.9
		Shell				20
P08*	Socket	HTD, 26 points	HTDA-26PTI-FO			10.3
		Shell		18		
P02	Socket	Sub-D, 15 points	340100201BDAMA15SNMB	FCI		11.5
		Shell	DA8949405-1NM			18
P05	Pin	Sub-D, 15 points	340100201BDAMA15PNMB		11.5	
		Shell	DA8949405-1NM		18	

Connectors at PSM/R5C, 50K end.

Name	Type	Description	Reference	Manufact.	Weigh (gr)
P21	Pin	Micro-D, 37 points	MWDM-2L-37PSP-429	Glenair	4.4
		Shell	500T010M37B09		12
P22	Pin	Micro-D, 25 points	MWDM-2L-25PSP-429		4
		Shell	500T010M25B09		10

Connectors at PSM/R5C, 300K end.

Name	Type	Description	Reference	Manufact.	Weigh (gr)
P121	Socket	Micro-D, 37 points	MWDM-2L-37SSP-429	Glenair	4.4
		Shell	500T010M37B09		12
P122	Socket	Micro-D, 37 points	MWDM-2L-37SSP-429		4.4
		Shell	500T010M37B09		12



Connectors at PSM/R5D, 300K end.

Name	Type	Description	Reference	Manufact.	Weigh (gr)
P101	Pin	Micro-D, 37 points	MWDM-2L-37PSP-429	Glenair	4.4
		Shell	500T010M37B09		12
P102	Pin	Micro-D, 37 points	MWDM-2L-37SSP-429		4.4
		Shell	500T010M37B09		12

4.5.2.2.4. Cables reference specifications

Type	Manufa cturer	Reference	Description	AWG	Ohmic Res. Ω /Km	Diameter (mm)	Weigh (gr/m)
A	Alcatel	BTV2/26/BF/G/AQS	Twisted pair, shield., jac., Copper	26	153	2.26	9.24
AA	Alcatel	MTV2/20/BF/G/AQS	Twisted pair, shield., jac., Copper	20	33.8	3.36	21.7
B	Alcatel	MTV2/16/BF/G/AQS	Twisted pair, shield., jac., Copper	16	17.3	4.98	47.8
C	Habia TBC	-	Twisted pair, shield., Core stainless Steel	38	-	-	-
D	Habia TBC	-	Twisted pair, Stainless Steel shield., core Copper,	38	-	-	-
E	Habia TBC	-	Twisted pair, Stainless Steel shield., core Copper,	32	-	-	-



4.6. SCS Grounding

The SCS grounding scheme is shown in Figure 4-10, All the SCS units are designed in compliance with ESA grounding requirements.

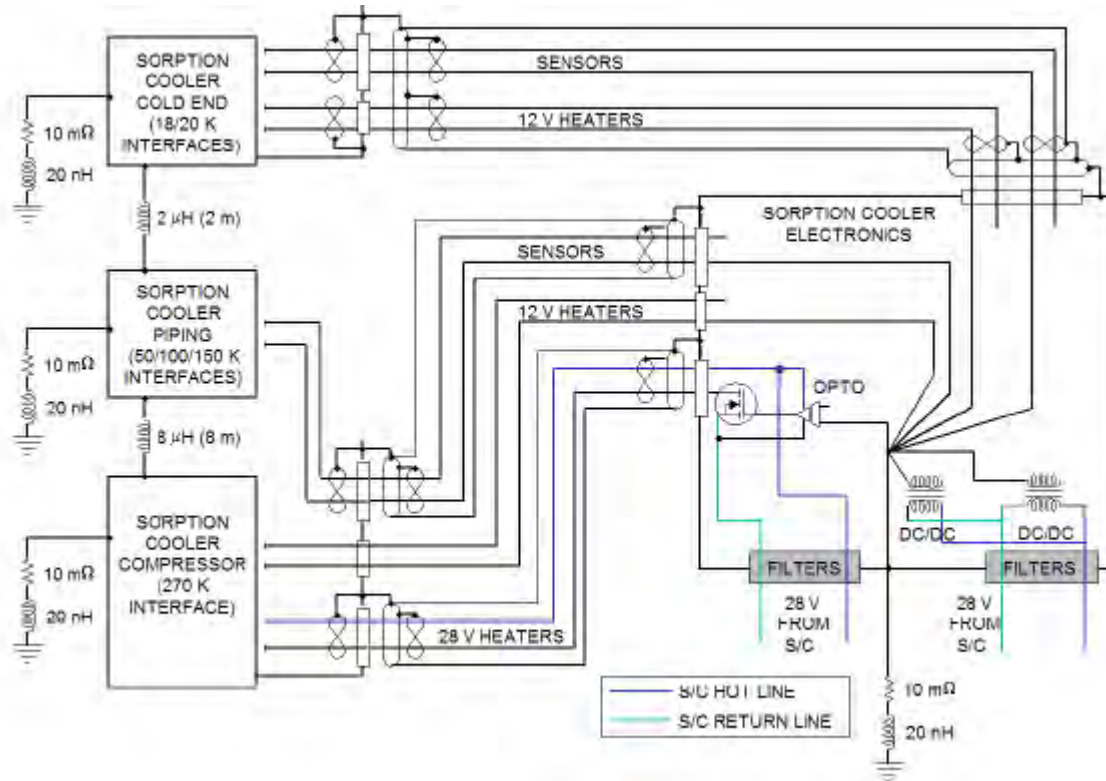

Figure 4-10 SCS Grounding Scheme



5. Planck SCS Performance

Both SCS (FM1 and FM2) achieve the following performance while operating within the flight allowable temperature ranges listed in Table 5-1.

Interface ⁶	Non-Operating ²			Operating ³	
	Flight allowable		Power ON ¹	Flight allowable	
	Min	Max		Min	Max
LVHX1	17.5	323	≤100	NA	NA
LVHX2 + TSA	17.5	323	≤100	NA	NA
PC3 (A,B,C) ^{4,5}	40	323	≤60	45	60
PC2 ^{4,5}	90	323	N/A	100	120
PC1 ^{4,5}	150	323	N/A	150	170
Warm Rad ^{4,5}	252	323	≥252	262	282

Table 5-1 TMU Interfaces Temperatures

Notes:

- 1) Power-On is the temperature at which power can be applied to a non-operating TMU.
- 2) Non-Operating Flight Allowable temperatures are mission temperature limits (including allowance for prediction uncertainties) in a worst-case powered-off, non-operational mode that the thermal control is designed to maintain for specified assemblies and subsystems (hot or cold).
- 3) Operating Flight Allowable temperatures are the mission temperature limits (including allowance for prediction uncertainties) in a worst-case powered-on, operational (operating within functional specifications) mode at which the thermal control is designed to maintain for specified assemblies and subsystems (hot or cold).
- 4) All interface temperatures are defined to be on the TMU side of the interface.
- 5) These interface temperatures are supplied by the spacecraft and are used as is - no internal design margins to account for prediction uncertainties of these interfacial temperatures are included within the TMU for design purposes.
 - a. Note: All Sorption Cooler Compressor (SCC) Isolation Valves (except for fill and purge valves) to remain in fully open position during non-operational storage, environmental testing and operational testing. This is to ensure that excessive pressures do not get produced in confined volumes when the system is subjected to > 310 K temperatures.
 - b. The TMU can be switched on at ambient temperature/pressure to perform health checks for very short durations. The PACE sensors and the SCC heaters/sensors can be energized for < 5 minutes. The PACE heaters can be energized for < 5 seconds.
 - c. There will be no bake-out performed on the TMU system (per communication from Alcatel).



5.1. Cold End Temperature

The TMU shall maintain temperatures at the interfaces and levels defined in Table I.

Interface ⁽¹⁾	Flight Allowable Operating (K)	
	Min.	Max.
a. LVHX1	17.5	19.02
b. LVHX2+TSA	17.5	22.5

Table 5-2. Cold End Temperatures to be maintained by TMU

Notes:

- 1) All interface temperatures are defined to be on the TMU side of the interface.
- 2) The LVHX2+TSA maximum temperature goal is <21.8 K. TSA simultaneously perform the action done by LVXH3 and controls the temperature fluctuations at the LFI interface.
- 3) LVHX2+TSA temperature is coupled to TMU tuning adjustments (through table uploads in the LPSC software) during flight to respond to TMU performance degradation. There is a minimum LVHX2+TSA temperature below which the adjustments cannot be performed. The minimum TSA operating temperature is measured during ground test.

5.2. Temperature Stability

Peak to peak oscillations in LVHX1 and LVHX2+TSA temperatures at the TMU Operating Point defined in Table 5-1 are within the values in the following table.

Interface	Temperature ⁽²⁾ Fluctuation (P.toP.) over one TMU Operating Period ⁽¹⁾
LVHX1	≤ 450 mK
LVHX2+TSA	≤ 100 mK ⁽³⁾

Table 5-3. TMU Temperature Stability

Notes:

- 1) TMU Operating Period is one complete cooler cycle time
- 2) Temperature is measured on LVHX1 and LVHX2+TSA, and reported for the condition of zero attached thermal mass.
- 3) These fluctuations at LVHX2+TSA assume the complete implementation of a Thermal Stabilizer Assembly (TSA) as specified in TMU Specification Document.



5.3. Cooling Capacity

The SCS provides the indicated cooling capacity at the Operating Points defined in Table 5-1.

Instrument	Interface	Heat Lift (mW)
HFI at 18K	LVHX1	≥ 190
LFI at 20K	LVHX2+TSA	≥ 796 ¹
<i>Total</i>		≥ 986

Table 5-4 SCS Total Cooling Requirements

Notes:

- 1) Accounts for 150 mW allocated and agreed to by LFI, to implement PID at LVHX2 interface per TSA (near LVHX2) to a < 100 mK fluctuation level.
- 2) For a TMU Total Input Power of 470 W
- 3) Accounts for parasitics from active and redundant coolers

5.4. Heat Lift Adaptability

When the heat lift need on the TMU changes, the TMU (exploiting a specific operating algorithm, see Chapter 6) is re-configurable to provide the required cooling power at the LVHX1 and LVHX2 interfaces within a range bracketed by the maximum values shown in Table 5-4 and minimum values shown in Table 5-5 while meeting its requirements in Table 5-2 and Table 5-3 and operating in a predictable and safe manner, suffering no damage.

Interface	Min. Heat Lift
LVHX1	10 mW
LVHX2	400 mW

Table 5-5. TMU Minimum Heat Lift

5.5. Lifetime

The SCS Nominal + Redundant is capable of operating 6 months before launch (including 3 months at JPL and 3 months during European operations) and 18 months on-orbit with a maximum of 3 regeneration operations. SCS FM2 is considered the Nominal unit because already regenerated once. The need for more regeneration processes on FM1 or FM2 is evaluated on the basis of the thermal boundary conditions, mission duration and scanning strategy. This evaluation will be done before and during mission with the help of a specific analytical model, provided separately by JPL, in order to optimize SCS operations to achieve the required observation time.

5.6. Regeneration

Regeneration is the TMU internal operation that allows recovery of the hydride degradation during operations (see Chapter 9). During the regeneration operation the TMU will not provide heat-lift, temperature and temperature stability at the Cold-End.



The mean time between regenerations for the TMU will be greater than 9 months and the mean time to regenerate will be less than 10 days (ground regeneration).

5.7. Cool Down

During the instrument (LFI/HFI) cool down the TMU shall provide the cooling capacity depicted in Table 5-6 to cool the LVHX1 and LVHX2 interfaces (on TMU side). The powered Planck TMU shall be capable of this cooling capacity only when the temperatures of LVHX1 and LVHX2 are $\leq 100\text{K}$, and when the temperature of PC3 (on the 3rd V-Groove) is $\leq 60\text{K}$.

Total Cooling Capacity	$\geq 340\text{ mW}$	$\geq 450\text{ mW}$	$\geq 590\text{ mW}$	$\geq 780\text{ mW}$	$\geq 890\text{ mW}$
when LVHX2 Temperature is	$\leq 100\text{ K}$	$\leq 80\text{ K}$	$\leq 60\text{ K}$	$\leq 40\text{ K}$	$\leq 30\text{ K}$
and PC3 Temperature is	$\leq 60\text{ K}$	$\leq 60\text{ K}$	$\leq 60\text{ K}$	$\leq 60\text{ K}$	$\leq 60\text{ K}$

Table 5-6. TMU Cooling Capacity Available During Cooldown

5.8. Measured Performance

The results of JPL ground testing before delivery to ESA and of PFM1 and PFM2 Test Campaigns at CSL on the Flight Model spacecraft, confirm the above listed performance and can be summarized in the following table:

Test Campaign	Test Case	WR T (K)	PC3C T (K)	Instr IF T (K)		Heat Lift (mW)	Input Power (W)	Cycle Time (s)
				LVHX1 ¹	TSA ¹			
JPL FM1 Test SCS-R	Nominal TMU I/F's	269	52	17.1 (0.4)	18.7 (0.11)	950 \pm 50	345	760
	Max LVHX T	282	60	18.6 (0.44)	20.7 (0.16)	1115 \pm 50	387	667
JPL FM2 Test SCS-N	Nominal TMU I/F's	269	50	17.15 (0.37)	18.7 (0.15)	1050 \pm 50	345	760
	Max LVHX T	282	60.6	18.4 (0.37)	19.7 (0.09)	955 \pm 50	387	667
CSL PFM1 Test SCS-R	Cold SCC TB	270.5	45	17.2 (0.42)	18.7 ²	1100 \pm 50	297	940
	Ref SCC TB	282.6	60	18.4 (0.5)	20.4 ^{2,3}	1050 \pm 50	388	667
	Hot SCC TB	277	60	18.0 (0.31)	20.1 ^{2,3}	1100 \pm 50	460	492
CSL PFM2 Test SCS-N	Cold SCC TB	270	47	17.1 (0.55)	18.7 (0.12)	1125 \pm 75	304	940
	Hot SCC TB	273	48	17.5 (0.35)	18.7 (0.06)	Not measured	470	525

Table 5-7 SCS-N and R ground test results summary

Notes:

- 1) Between parenthesis are reported the peak-to-peak T fluctuations.
- 2) During SCS-R PFM1 Test campaign at CSL, the TSA active control system was not used
- 3) Measured at TSA stage in balanced conditions with nominal instrument loads



6. Sorption Cooler System Operations Modes

6.1. Planck SCS Operations

6.1.1. Required Operational Capabilities

The functional requirements listed in table 1 specify the performance of the Planck Cooler during nominal operation. In theory, the cooler will be operating at nominal condition for virtually all of its specified lifetime (~18 months). Control of the cooler in these “steady” conditions is relatively simple, consisting primarily of timer-based heater cycling. The major challenges during operation occur when the cooler is functioning at off-nominal conditions. Examples of this are initial cooler power-up, recovery from power outages, and J-T plug detection/removal.

6.1.1.1.1. Nominal/Steady-State Operation

The term steady state defines the condition in which the cooler is in stable operation, with a fixed cycle time of 667 s, while meeting all the functional requirements listed in Table 1. This can be achieved only when the cooler operating parameters are within their nominal ranges. In particular, there are three parameters that represent the status of the cooler: HPST pressure, mass flow and J-T temperature. In order to provide sufficient flow rate to achieve the heat lift requirements, the HPST pressure must exceed some minimum value, and the J-T temperature must be below some maximum value (the impedance of the porous plug J-T to flow increases with temperature).

6.1.1.1.2. Cooler Startup

Startup is the transitioning process that prepares the cooler to enter steady state operations. In order to reach this point, HPST pressure, mass flow and J-T temperature need to reach their nominal values.

In the case of the *initial startup*, the cooler is in a known state: once the spacecraft has reached a stable orbit the pressure on both sides of the J-T expander will be sub-atmospheric (~500 Torr), while the temperature of the cold end components will be around 80K.

During this initial startup, the compressor element heaters must be cycled while applying heat to the LPSB. This results in hydrogen being moved from the LPSB into the beds, which then desorb into the HPST. As the process continues, the HPST pressure builds, and eventually reaches its nominal value (~4.8Mpa). This condition is reached quickly (<12 hours) because the high J-T temperature does not allow a substantial mass flow. From this point on, all that is required is to maintain the pressure around the nominal value. As the cold end components are slowly cooled by the limited heat lift initially produced, the mass flow increases. This positive feedback effect eventually results in both the mass flow and the J-T temperature reaching their nominal values. At this point the cooler is ready for steady-state operation.

Once the initial startup is complete, the cold end of the cooler should remain within its nominal temperature range (17-22K) throughout the remainder of the mission. However, the occurrence of a number of anomalous events has been anticipated. One such anomaly is an interruption of electrical power. Another example is the porous plug J-T becoming clogged. The state of the cooler following such anomalies cannot be predicted, contrary to the case of initial cooler startup. A short power outage (~120 sec) may result in nothing more than the HPST pressure dropping by 0.25kPa. However a power interruption lasting 30 minutes would result in most of the high-pressure hydrogen bleeding through the J-T. In the case of the J-T being plugged,



once the plug is removed, the J-T temperature can be very high (>80K), and the mass flow severely limited. Following the occurrence of such anomalies, a *cooler restart* is required, which aims to ready the cooler for steady-state operation, just as was the case with initial startup. But there is one major additional requirement placed on the restart process: The time to return to steady state operation must be made as short as possible. This is due to the fact that all anomalies share one common feature: They all result in a decrease in the amount of heat lift provided by the cooler. In the case of a power interruption, this is due to a drop in the HPST pressure, and in the case of a J-T plug, this is caused by a decrease in mass flow. If the available heat lift falls below the instrument power dissipation, the cold end temperature will begin to rise. In this event, the recovery time of the cryogenic chain being pre-cooled by LVHX-1 is on the order of 2 weeks, throughout which the LFI science data is compromised.

6.1.1.1.3. Plug Detection and Removal

One concern when operating a cooler with any J-T expander is the possibility of condensable contaminants freezing in the J-T, resulting in partial or full blockage of flow. The J-T and particle filter are both instrumented with heaters, which can be used to heat the porous material and melt the solid contaminants. Due to the absence of a flow meter in the flight cooler design, it is necessary to devise a method of operating the cooler in such a way as to provide an indirect indication of the mass flow through the J-T. This method must be able to autonomously distinguish between actual contaminants plugs and gas flow reductions due to off-nominal boundary conditions. Once a J-T plug is detected, the cooler control electronics should automatically power the J-T and/or particle filter heaters to remove the plug.

6.1.2. Cooler Operational Scheme

Testing of the EBB Cooler with the JPL electronics began in January of 2001, and continued through May of 2003. When testing commenced, most of the focus was on the evaluation of the cooler itself, as this was the first time the compressor and PACE were tested together as a system. During this period, the LabVIEW software running the cooler was very basic. Compressor element heaters were cycled according to a user defined time period, and all other heaters (LPSB and cold end heaters) were set manually. Once it was demonstrated that the cooler was functioning as designed, attention was turned to the development of the operating scheme to be used by the flight electronics. Throughout the development period, the focus was on keeping cooler operation as simple as possible, while still managing to satisfy all required capabilities.

6.1.2.1.1. Top-Level Description of Cooler Operation

The top-level model of the cooler operation can be summarized by a stoplight paradigm (see Figure 6.1). A red light signifies the cooler is OFF, meaning that no power is being applied to any heaters. The electronics continues to acquire data from all measurement channels to monitor the health of the cooler. This mode of operation is denoted as Ready Mode.

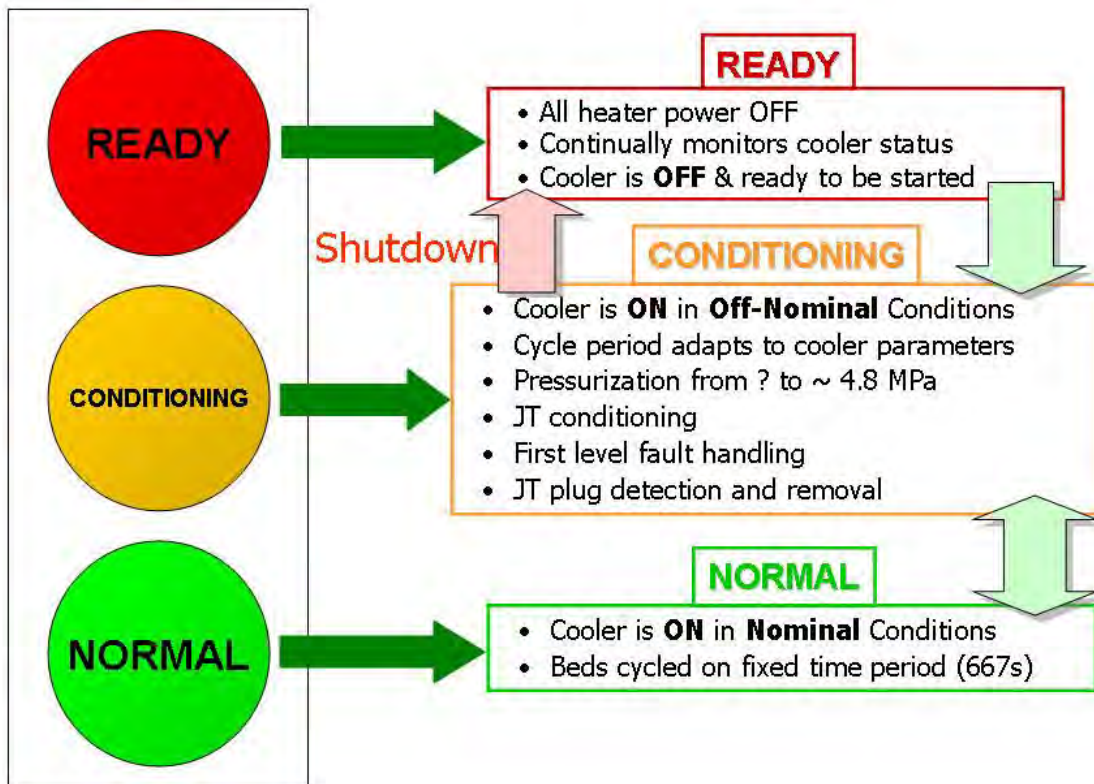

Figure 6-1 Stoplight model of cooler operation

The yellow light refers to Conditioning Mode, which is used to operate the cooler whenever any of the three major operating parameters (HPST pressure, J-T temperature, and mass flow rate) are outside of their nominal ranges. This includes initial cooler startup, cooler restarts, and J-T plugging. In conditioning mode, the bed heater cycle period is dynamically determined by a number of cooler parameters.

The green light refers to Normal Mode operation, in which the cooler will spend most of its operating lifetime. In this mode, all heater cycling is performed based on a fixed 667-second cycle period. Normal operation can only occur if all of the three major cooler parameters are at nominal levels. It is in this mode that the cooler requirements will be satisfied.

6.1.2.1.2. Ready Mode

In Ready mode, the cooler is OFF in the sense that no power is applied to any of the cooler heaters. All measurement channels are continually sampled with a scan rate of 1 Hz, while an autonomous “Health Monitoring” algorithm attempts to interpret the functional status of each sensor, comparing the readings to tabled values. This monitoring process is active in each cooler operating mode (Ready, Conditioning, Normal). A “Health Check” procedure can be run by command within Ready Mode. It applies small amounts of power to all heaters, and analyzes the responses of relevant sensors. This provides an accurate method of determining sensor as well as heater functionality. The objective of the above diagnostic processes is to ensure that the cooler is ready to be operated.

6.1.2.1.3. Run Mode

The RUN MODE contains:



- Conditioning State
- Normal State
- Defrost Procedure

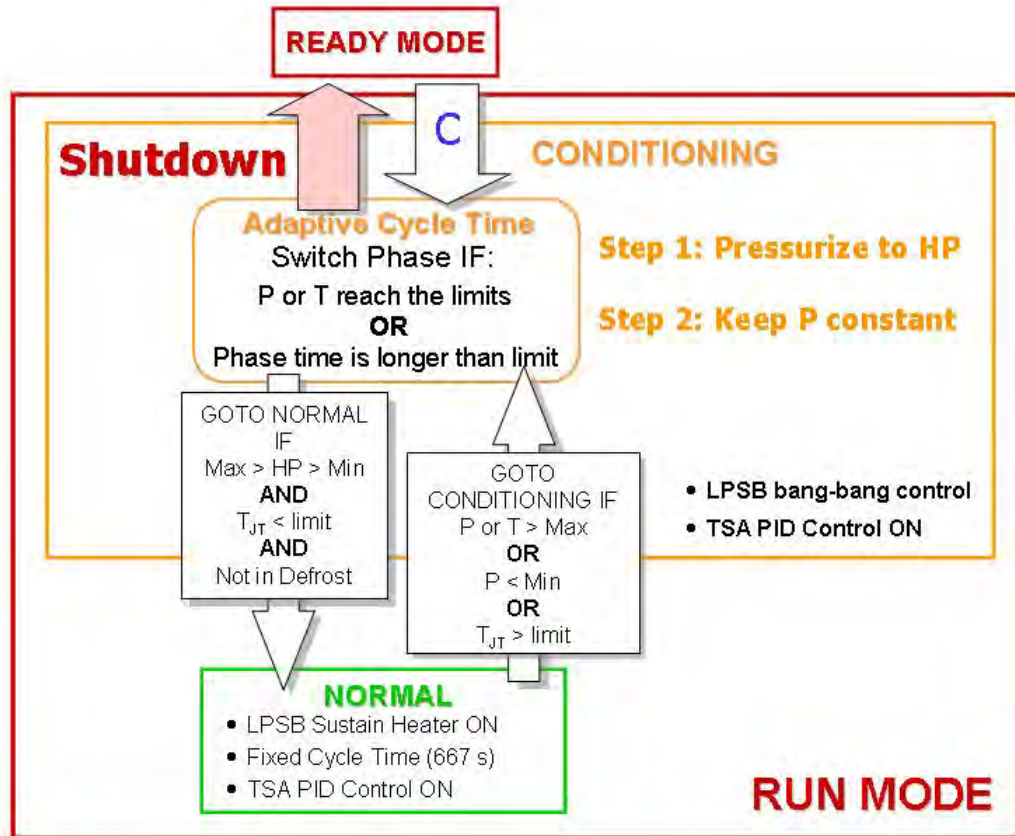

Figure 6-2 RUN Mode Block Diagram

6.1.2.1.4. Conditioning State

The Conditioning mode prepares the cooler for transitioning into Normal operation in the shortest time possible in accordance with the system starting conditions. This task is achieved by adjusting the key operational parameters into their nominal ranges with a process that can be summarized in two main steps:

1. Pressurization of high-pressure circuit to nominal value;
2. Maintaining pressure constant.

The key concept in the Conditioning mode is that the cycle time is not a fixed variable (like in Normal operation) but it is the consequence of triggers that force the compressor to move on to the next phase.

In order to pressurize the system as quickly as possible, each compressor element is forced to desorb all its H_2 by the application of heater power. Once the bed is empty, any further power applied results in the bed temperature suddenly rising. This temperature peak triggers the software to switch to the next phase where the following bed is taken into desorption. In the background, Conditioning mode implements a simple ON-OFF heater control of the LPSB temperature to distribute its stored hydrogen to the compressor elements.

Data illustrating the ability of Conditioning mode to rapidly pressurize the system is shown in Figure 6.3. During a simulated spacecraft power outage, the HPST pressure was allowed to



drop below 200 psia (1.4 Mpa). The power was then restored, and the cooler restarted in Conditioning mode. As seen in the plot below, Conditioning mode is able to build the system pressure up to 735 psia (~5 Mpa) within a period of 2 hours.

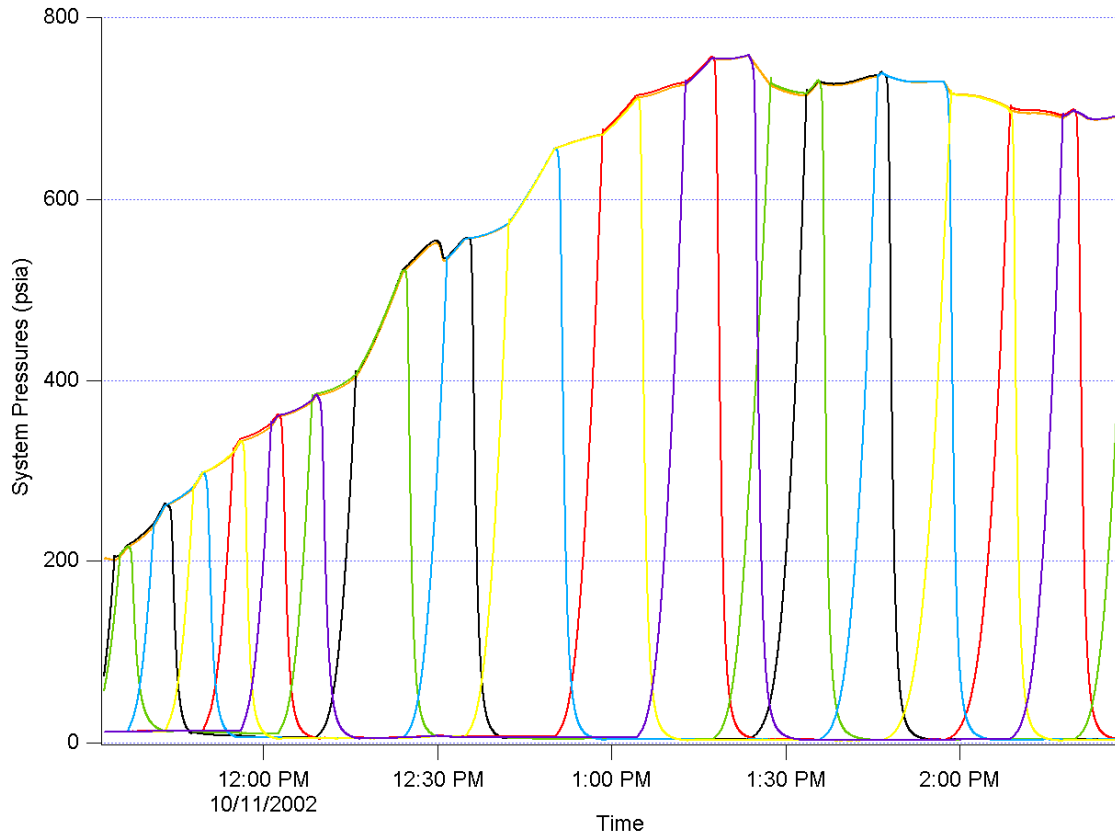

Figure 6-3 Rapid pressurization data using Conditioning Mode

Once the nominal value of the HPST pressure is achieved, Conditioning mode must keep it constant while waiting for the J-T temperature and mass flow to reach their steady state ranges. Conditioning mode allows each bed to desorb only the gas that is needed to keep the pressure constant and to sustain the present flow rate. As soon as the desorbing compressor element forces the HPST pressure to increase, this pressure rise triggers the bed to advance to the next phase and a new bed is switched into desorption.

A low mass flow condition can be attributed to two possible scenarios: a warm cold end or a J-T plug. In the first case, the low flow, inhibited by the high J-T temperature, is able to provide only a limited heat lift. This eventually cools down the cold end components, consequently producing a mass flow increase. This positive feedback process can result in rapid increase in mass flow, requiring a higher amount of gas desorbed by each compressor element. Conditioning mode is highly efficient in adjusting to these evolving conditions. Phase after phase it allows each bed to desorb a higher amount of gas in order to sustain the increasing mass flow while keeping the HPST pressure constant.

In the case of a J-T valve plug, mass flow is limited by contaminants condensed on the valve itself. Conditioning mode is able to distinguish this particular case from low flow levels due to J-T temperature conditions. The autonomous procedure to identify and recover from J-T plugs within the Conditioning mode is described in a dedicated paragraph.

Due to its adaptive nature, Conditioning is the ideal mode for fault handling. The detection and response to anomalies is described in a dedicated paragraph.



6.1.2.1.5. Normal State

Once the Conditioning mode has taken the three operational parameters to their nominal values, the system autonomously transitions to the Normal mode. This mode is the simplest way of operating the cooler. Bed heaters are cycled strictly based on a fixed 667-second time period, while the health monitoring in the background ensures that the cooler remains in its nominal conditions. If one, or more, of the operational parameters falls outside the normal range, the operation software forces the cooler to transition back to conditioning mode where the appropriate action is taken. In the case that the fault cannot be recovered in Conditioning mode the cooler is shutdown (see Fig.6.1).

In order to meet temperature stabilization requirements, two more processes are activated during Normal operation. Since the pressure fluctuations during absorption are a function of the H₂ concentration in the compressor, the Low Pressure Stabilization Bed's storage capacity is used to control the average H₂ concentration. This is accomplished by applying steady heater power to the LPSB to keep its temperature constant and to stabilize the quantity of gas absorbed/desorbed by the compressor elements. In addition, the cold end Temperature Stabilization Assembly is continuously active. This control system uses a software Proportional-Integral (PI) algorithm that processes the reading of a high-sensitivity thermometer and responds with power provided by a heater.

In case an anomalous condition is detected the cooler operation automatically transitions back to Conditioning mode where the appropriate action is taken.

6.1.2.1.6. Fault detection and response

In the design of an autonomous operation system, the detection of anomalies and the consequent response is of fundamental importance. If one of the predicted anomalies is detected in Conditioning or Normal mode, the cooler stays in or transitions back to Conditioning. An autonomous classification of faults is implemented in the software so that the system can respond to the anomaly in four possible ways:

1. *Fix* the problem by removing the cause (e.g. J-T plug)
2. *Adjust* cooler operation in order to compensate for the problem (e.g. compressor element heater or sensor malfunction)
3. *Tolerate* anomalies that do not affect cooler performance or safety (e.g. secondary temperature sensor malfunction)
4. *Shutdown* the cooler if system safety is threatened (e.g. HPST pressure exceeding safety limits)

In all cases communication of the failure is conveyed to ground control for documentation and/or response.

6.1.2.1.7. J-T plug detection and recovery

Plugs are one of the major risk factors of Joule-Thomson cryocoolers and particular attention to this failure mode was paid during cooler operation system design. It must be emphasized here that this plug removal procedure is not used to ensure safe cooler operation. Safe operation is ensured by the CONDITIONING procedure and the continuous monitoring of the system pressure and compressor element temperatures. The main issue of this procedure is the detection of a plug and autonomous removal to prevent long periods where the cooler can no longer provide heat lift.

An obstruction of the J-T valve manifests itself as a sudden decrease of mass flow and a sudden increase of HPST pressure. However a rise in pressure, being symptomatic of several phenomena as well, is not a sufficient condition to identify a plug. Proper detection of a valve



clogging should be based on more indicators, specifically mass flow measurement. Since the cooler circuit does not include a flow meter, a direct flow measurement is impossible. The adaptability of Conditioning mode suggested an efficient and robust procedure to indirectly estimate flow and recover from a possible plug. This procedure uses the bed cycle time to determine if the J-T is plugged. When a plug occurs, gas flow out of the HPST will stop or decrease and the pressure will rise as the desorbing bed evolves gas. The CONDITIONING Mode advances the cycle time when the high-pressure limit is reached and the cycle time will decrease as flow out the HPST is restricted or stopped. It is this decrease in cycle time that the defrost procedure uses for plug detection. In order to generate flow from a compressor element, enough energy must be deposited into the compressor element to heat it to the desorption pressure and maintain it there; thus mass flow can be related to energy deposited into the desorbing compressor element. This is not the entire story as the procedure must be able to account for the strong temperature dependence of the J-T flow impedance. To do this, the software logic starts from the assumption that once the desorbing bed has reached the pressure limit, all the extra heater power applied to the hydride should result in gas flowing out of the bed. Since the characteristics and behavior of each compressor element are well known, it is possible to calculate the average mass flow that should be desorbed by the bed when provided with that amount of power. By maintaining the HPST pressure constant, Conditioning mode is essentially ensuring that the mass flow emitted by the bed and entering the HPST is equal to the flow leaving the tanks itself and supposedly flowing through the J-T restriction. On the other hand, there is a direct relation between the mass flow through the J-T, its temperature, and the pressure on its high-pressure side. The pressure of the circuit is kept constant at the nominal value, the temperature is constantly monitored, and the restriction valve used in the cooler is very well characterized: this adds up to an accurate estimate the expected gas flow. If the compressor element average mass flow is lower than that expected for the present J-T temperature and HPST pressure, the software detects the first hint of a possible plug. This first indication, however, must be supported by the concurrence of the other conditions that participate to positively identify and discriminate the plug:

- the pressure in the tank is in the nominal range **AND**
- the J-T temperature is less than a maximum limit

If these 3 conditions are met, the software perceives this status as a plug and activates the Defrost process by automatically energizing the J-T heater. This heater will stay ON for a specified time or until the J-T valve reaches a pre-determined temperature, selected according to the predicted contaminants. While the defrost heater is ON, the CONDITIONING mode continues to operate the cooler and prevents the system from transitioning to the NORMAL mode.

Figure 6.4 contains data detailing a plug event. As soon as the J-T becomes clogged, the mass flow suddenly drops and the HPST pressure rises. The cooler software detects the plug, and reacts quickly by energizing the J-T heater as seen on the plot of J-T heater current. This results in the J-T temperature rising. Once the J-T reaches the prescribed temperature limit of 180K, the heater is turned off, and the J-T temperature falls. The nominal mass flow rate is recovered within ~3 hours of the initial onset of the plug.

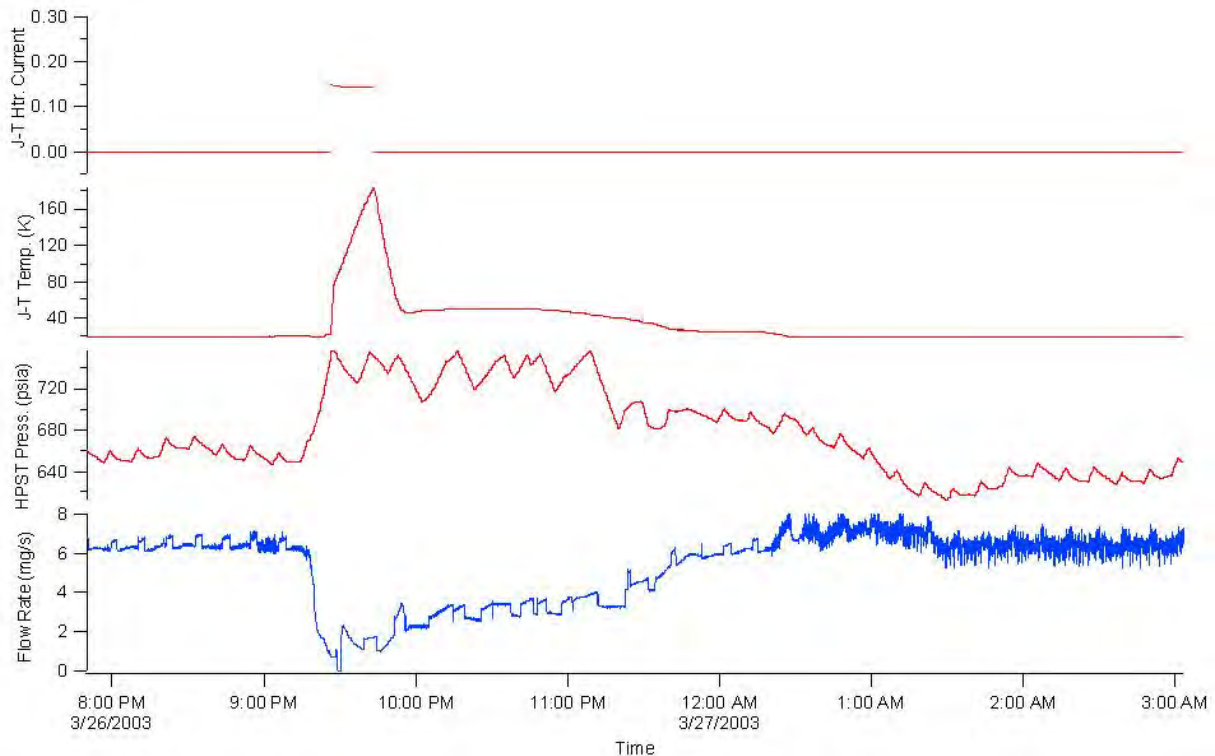

Figure 6-4 Autonomous plug detection and removal event

The ability of the Sorption Cooler Electronics to autonomously operate the Planck Sorption Cooler is not only vital to the performance of the cooler, but to the entire Planck Mission. Since communications with the spacecraft are limited, it is possible for a fault condition to occur 22 hours before the next ground communication. A less intelligent operating scheme might simply shutdown the cooler in the event of a fault condition, and wait until the cooler operators on the ground have a chance to interpret the cooler data. The repercussions of this type of fault handling could be detrimental to the quality and quantity of science data produced by the Low and High Frequency Instruments. A J-T plug, for example, would not only result in the LVHX interface temperatures rising above their specifications. After several hours of time with no available heat lift, the entire HFI cryocooling chain would heat, requiring time on the order of two weeks to recover. Similar problems could result in the event of a long-term spacecraft power interruption. This explains why so much effort has been put into making the cooler operational scheme so intelligent. The adaptive nature of Conditioning mode coupled with autonomous J-T detection and removal and multi-level fault classification has made the cooler electronics much more tolerant of anomalous conditions that might arise during the cooler's operating lifetime. This ability to minimize the time spent in "off-nominal" operation results in an essential accomplishment for the successful achievement of the Planck mission scientific objectives.



6.2. SCS OPERATION MODES

Figure 6-5 illustrates the whole diagram of the SCS Operation Modes and the possible transitions between them.

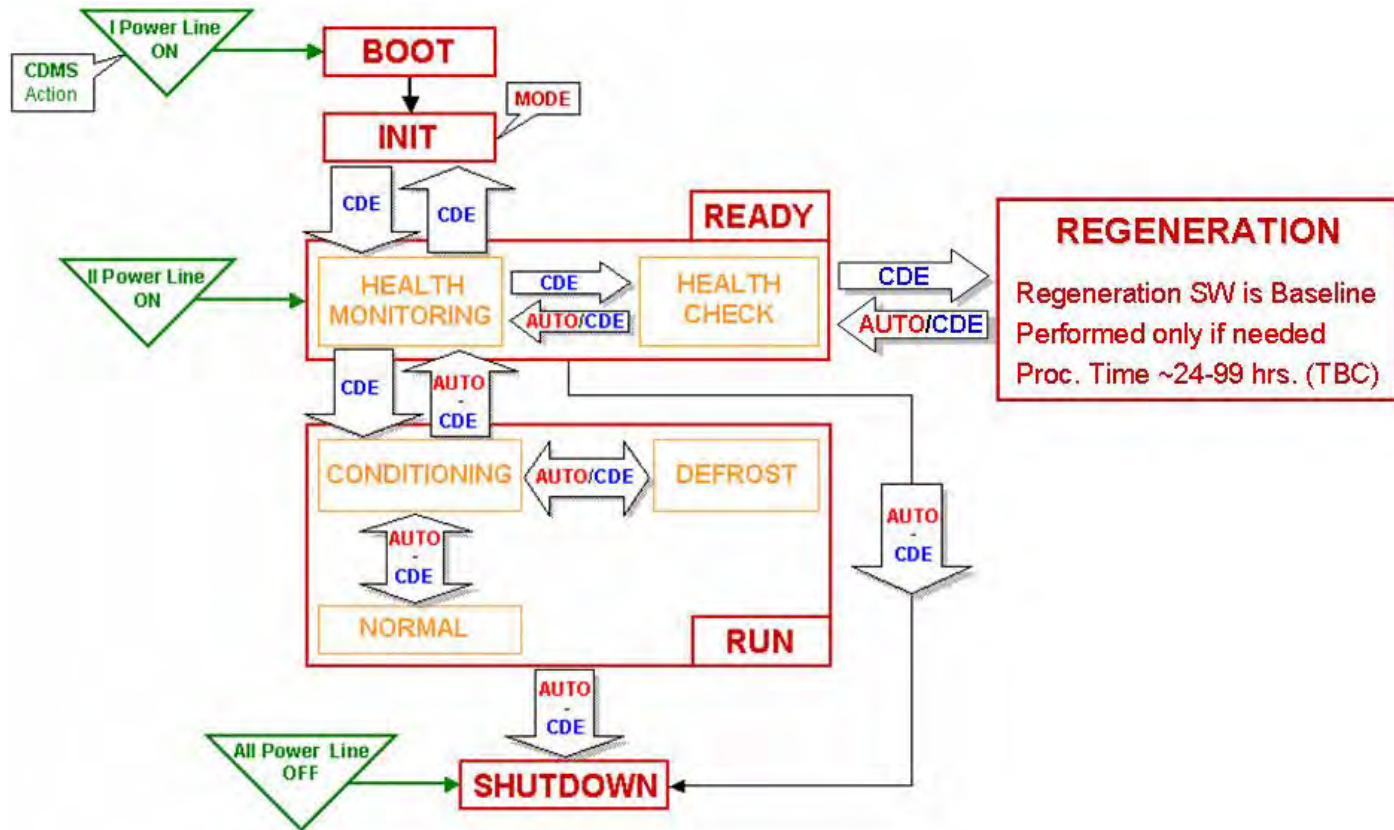

Figure 6-5 Cooler Operations Diagram

The table below shows the **status** of the Sorption Cooler Subsystem units in the main modes of operation. Details of each Mode are listed in the next paragraphs and in Par. 8.3.

Unit	Launch or OFF	Boot	Init	Ready		Run			Shutdown
				Health Monitoring	Health Check	Start-up	Defrost	Normal	
TMU	OFF	OFF	OFF	ON	ON	ON	ON	ON	OFF
SCE	OFF	ON	ON	ON	ON	ON	ON	ON	ON
HK	NO	YES	YES	YES	YES	YES	YES	YES	YES

Table 6-1 Status of SCS subsystems in Op Modes

Notes:

- 1) ON= Operational;
- 2) OFF= Inactive;
- 3) Reminder: There is no mode of operation in which units of both the Nominal and Redundant Sorption Cooler Subsystem operates simultaneously.



MODES	STATES	OPERATIONS	COMMANDS
OFF	OFF	None: System can be handled and transported safely	
BOOT		Perform system boot up	ARE YOU ALIVE
		Initialize 1553	GOTO BOOT
		Acquire CDMS Command/Telemetry clock and timing signal	GOTO INIT
		Check PROM, RAM and EPROM	MEMORY UPLOAD
		Transfer Program from EPROM to RAM	MEMORY DUMP
		Check Software Transfer	
		One housekeeping at the end (Electronics and Software parameters)	
INIT		Soft reboot of the System	ARE YOU ALIVE
		Re-initialize 1553	GOTO INIT
		Housekeeping (Electronics and Software parameters)	GOTO READY
			SET INITIAL CE STATE
			MEMORY UPLOAD
			MEMORY DUMP
READY	Health Monitoring	The 2nd power line is requested from the CDMS	ARE YOU ALIVE
		Health Monitoring is automatically performed when enters READY Mode	GOTO INIT
		Check if P and T sensors are correct. Bad sensors are removed from Health Check	GOTO READY
	Healthcheck	Check Compressor Assembly and Cold End by performing actions	GOTO SHUTDOWN
			GOTO HEALTHCHECK
			EXIT HEALTHCHECK
			SET INITIAL CE STATE
			MEMORY UPLOAD
	MEMORY DUMP		
RUN	Conditioning	Executed each time the cooler is starting up or is trying to solve some faults before transitioning to Normal State	GOTO READY
		Jump to this State automatically when enters in RUN Mode	GOTO RUN
		Able to run with 6, 5 and 4 beds	GOTO SHUTDOWN
	Defrost	JT and Particle Filter heaters ON for a certain time or until a certain T	MEMORY UPLOAD
		If necessary Defrost is launched automatically from Conditioning	MEMORY DUMP
	Normal Operations	Normal Ops. Beds are powered following the defined sequence	
		Initiation of Normal Ops State is allowed only after one cycle into Conditioning State is completed	
		Each State of the RUN Mode is operated for an integer number of cycle ≥ 1 . Fractional cycles are precluded except for critical emergency response. Can exit during mid-cycle to Conditioning State	
		Able to run with 6, 5 and 4 beds	
		LR3 PID + OPEN LOOP regulation every second (1Hz)	



SHUTDOWN	READY-like Mode with GGA OFF, bed heaters OFF, LR3 OFF, etc.	
	Cooling is stopped, cooler's return to ambient conditions is monitored via housekeeping data	
	When P's return to ambient limits, the CDMS is requested to remove the 2nd Power Line	
	When T's return to ambient limits, the CDMS is requested to remove 1st Power Line	
	Receive/Acknowledge software/values patching instructions (lookup table, etc.)	
	Control and Monitor heated beds cool-down	
	Monitor System and Report Alarm/Fault Conditions	
	High data rate housekeeping	
	System Monitoring executed for TBD min. After SHUTDOWN	
	End of SHUTDOWN Mode corresponds to READY Mode with Power Lines OFF	

6-2 SCS Op Modes processes and actions list

6.2.1. BOOT Mode

The boot mode is entered automatically at the Sorption Cooler Electronics switch on. It can also be reached by the "GO TO Boot" telecommand from Boot or Init Mode: reset of the DSP is performed and Boot Mode is launched from scratch.

When Boot Mode starts, a series of hardware tests are launched (1553, FPGA, PM ROM, PM RAM, DM RAM, DM EEPROM), unless this check is disabled.

Then, the applicative software is transferred from EEPROM to RAM autonomously, unless disabled but this operation **needs** to be performed to launch the applicative software.

In BOOT Mode no TM(5) is generated, so no event is reported when entering BOOT.

6.2.2. INIT Mode

The Init Mode is reached by the "GO TO Init" telecommand from Boot, Init or Ready Mode: if transition Boot to Init, reset of the DSP is performed and PM PROM and PM RAM memory will be swapped in order to execute the applicative software previously stored in PM RAM memory.

When Init Mode starts, a series of hardware tests (PM PROM, DM EEPROM, External Timers, ADC Busy) can be launched (has to be enabled in LUT).

Next software initializations are performed.

Electronics sensors are read and reported to telemetry:

- ▶ Voltages
- ▶ Intensity
- ▶ Electronics temperatures

To exit Init Mode, the "GO TO Boot", "GO TO Init", "GO TO Ready" telecommand must be launched.

When entering INIT from BOOT no event TM(5) is generated, while TM(5,1) ID=2 is always sent when entering from any other Mode.



6.2.3. READY Mode

The READY Mode is the first module to allow direct operations on the cooler.

When entering in READY the system requests the activation of the 2nd power line from CDMS: as soon as this line is ON the execution can proceed.

The READY Mode is mainly used to run tests and checks on the SCS, before starting of operations. Two main procedures are present: the Health Monitoring process and the Healthcheck process (see Figures 6.5 and 6.6).

If no fault is detected the system can safely proceed into RUN Mode, in case of fault detection alarms will be set off in order for the operator to take the relative action before entering into RUN.

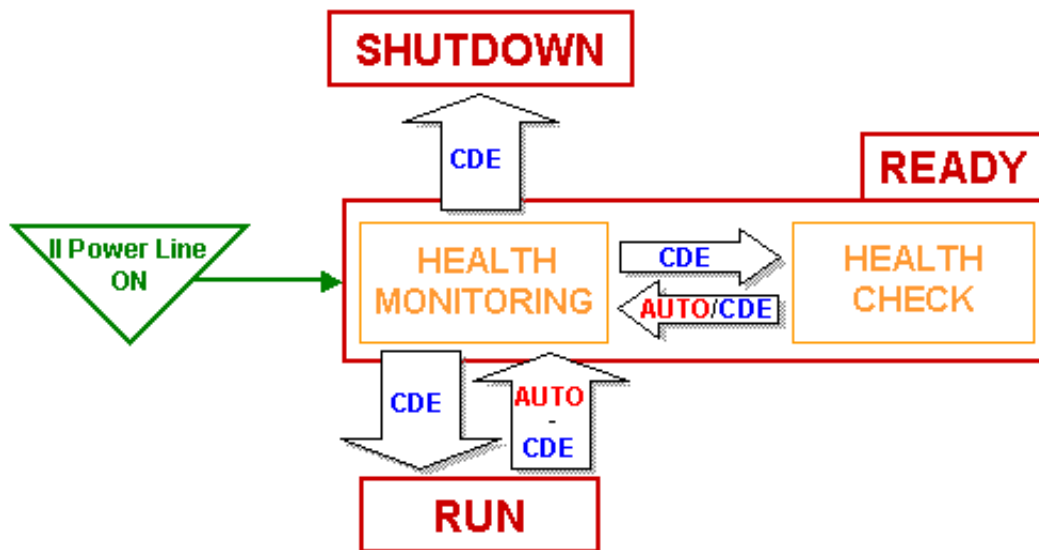

Figure 6-6 READY Mode

6.2.3.1. Health Monitoring

The **Health monitoring** procedure is automatically performed after entering into READY Mode. It consists of the readout of all the system sensors (T and P), checking that all the values result within the cooler safety limits. Once the health monitoring process has confirmed the functionality of the system sensors, the health check procedure can be started by *command*. If one or more sensors fail the monitoring test this subset will be excluded from the health check procedure: a flag will be raised and a message generated to communicate the failure in order to establish the appropriate actions.

6.2.3.2. Health Monitoring Procedure

1. For $i = 1$ to 30, read T_i , compare it with T_{i_safety} limit in table: if NOT inside range then raise flag (TBC/D)
2. For $j = 1$ to 8, read P_j , compare it with P_{j_safety} limit in table: if NOT inside range then raise flag (TBC/D)



6.2.3.3. Healthcheck

The **Healthcheck** procedure task is to check that the cooler is ready for operations by testing that all heaters circuits are properly functioning. The Healthcheck procedure will perform all the verifications on the heating circuits without taking any decision on the results. It is the ground operator task to compare those data with previous run and with proper parameter range, in order to interpret the status of the system and to decide on how to operate the cooler.

During the whole health check procedure the cooler safety limits will be continuously monitored to ensure the safety of the system.

6.2.3.3.1. Healthcheck Procedure

Compressor Assembly Test:

1. All sensors OK from health monitoring process? If NOT exclude the subsystem from Healthcheck and inform operator.
2. LPSB
 - a. Read initial low pressure sensor (LP_{INI}); Sustain heater ON (Max Power) until low pressure greater than $LP_{INI} + \Delta P_{LP}$ Low P OR time heater ON $> time_{limit}$; heater OFF
 - b. Startup heater ON until T_{17} greater than $T_{LP-LIMIT}$ OR time heater ON $> time_{limit}$; heater OFF
3. Compressor Elements
 - a. All CE Heaters OFF, all GGA OFF
 - b. CE#1 heaters ON (max power (CE)) until temperature of the bed $> T_{BED-LIMIT}$ OR pressure of the bed $> P_{BED-LIMIT}$ OR time heater ON $> time_{limit}$; heater OFF
 - c. CE#1 heater ON (min power, only on variable heater circuit) until time heater ON $> time_{limit}$; heater OFF
 - d. CE#1 gas gap heater ON until time heater ON $> time_{limit}$; heater OFF
 - e. Repeat step a, b, c, d for each CE (2,3,4,5,6, and again 1)

Cold End Test:

1. Read initial JT temperature sensor $T_{7initial}$ and $T_{30initial}$; turn JT heater H34 ON UNTIL $T_7 > T_{7initial} + \Delta T_{COLD}$ OR $T_{30initial} + \Delta T_{COLD}$ OR time heater ON $> time_{limit-cold}$, H34 heater OFF
2. Read initial JT temperature sensor $T_{7initial}$ and $T_{30initial}$; turn JT heater H35 ON UNTIL $T_7 > T_{7initial} + \Delta T_{COLD}$ OR $T_{30initial} + \Delta T_{COLD}$ OR time heater ON $> time_{limit-cold}$, H35 heater OFF
3. PF heater H33 ON: time heater ON $> time_{limit-cold}$, H33 heater OFF
4. PF heater H36 ON: time heater ON $> time_{limit-cold}$, H36 heater OFF



5. Read initial LR3 temperature sensor $T_{5initial}$ and $T_{6initial}$; turn LR3 heater H31 ON UNTIL $T_5 > T_{5initial} + \Delta T_{COLD}$ OR $T_{6initial} + \Delta T_{COLD}$ OR time heater ON > $time_{limit-cold}$, H31 heater OFF
6. Read initial LR3 temperature sensor $T_{5initial}$ and $T_{6initial}$; turn LR3 heater H32 ON UNTIL $T_5 > T_{5initial} + \Delta T_{COLD}$ OR $T_{6initial} + \Delta T_{COLD}$ OR time heater ON > $time_{limit-cold}$, H32 heater OFF

6.2.4. RUN MODE: an overview

The RUN Mode is the frame that identifies the main functioning environment of the cooler during operations. In this Mode the cooler can operate in only two possible States: CONDITIONING and NORMAL (Fig.5.7).

The CONDITIONING State is called each time the cooler is Starting Up or is in some “fault detection situation” and trying to solve the problem. In the first case, once the *nominal conditions* (i.e. a set of tabled values of T and P for the Compressor and Cold End subsystems) have been reached, the system can transition to the NORMAL State. In the occurrence of an alarm status during NORMAL (or CONDITIONING) the SCS returns (or stays) into CONDITIONING, where it tries to re-adjust to the nominal conditions, where possible, before transitioning to the NORMAL State. Basically the CONDITIONING is the *only* State allowed to transition directly into NORMAL.

The NORMAL State is the nominal process that controls and monitors the cooler once it has reached its fully operational conditions, requirements and performance.

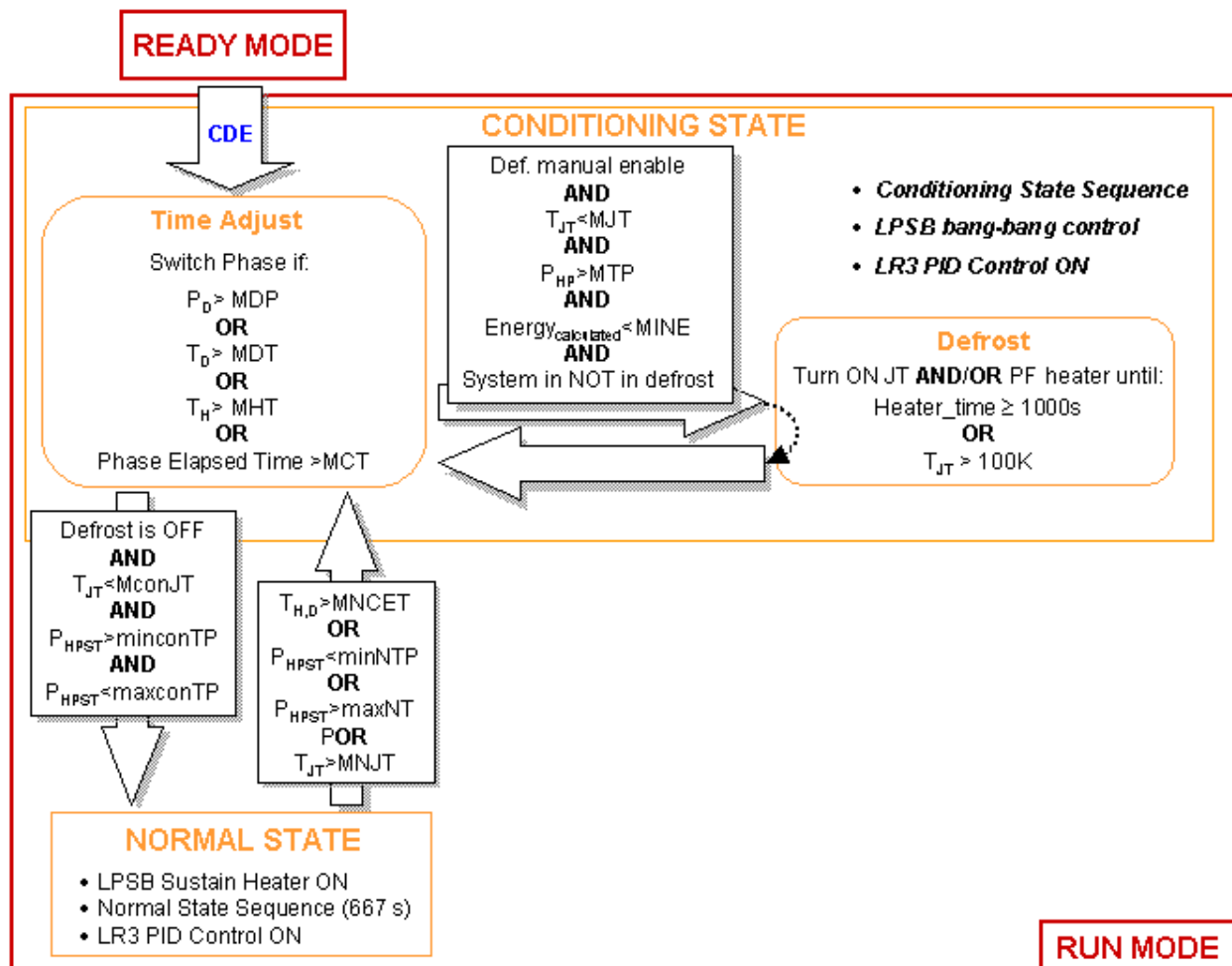

Figure 6-7 RUN Mode



6.2.4.1. Conditioning State

When the RUN Mode is called by *command* from the READY Mode, the system automatically enters the CONDITIONING State: the main objective of this State is to get the cooler ready to transition into NORMAL by taking it in *nominal conditions*, whether the cooler is starting up or recovering from a fault condition.

To achieve this situation the State is logically structured in a totally different way with respect to NORMAL: in order to speed the start-up operations up and to safely include a Defrost Procedure, in the Conditioning sequence each compressor element phase time is not a fixed variable (like in NORMAL) but it is the consequence of triggers that force the compressor to switch to the next phase.

At the very beginning of operations the first two beds are heated (one in heat-up phase, one in desorption) while all the other four beds remain cold, with GGA's ON, connected to the radiator. Then the software basically switches from phase to phase (see Figure 5.7) only when one of the following triggers (defined in a table) is set:

- Pressure of the Desorbing CE greater than Maximum Desorption Pressure (MDP)
- Temperature of the Desorbing CE greater than Maximum Desorbing Temperature (MDT)
- Temperature of the Heatup CE greater than Maximum HeatUP Temperature (MHT)
- Elapsed time in the current state greater than Maximum Cycle Time (MCT)

It is worth mentioning here that there are two "Maximum Cycle Time" values:

- One for the first cycle in conditioning after a transition from ready to run.
- One for all the others cycle in conditioning.

Note: during the first cycle, the transition to defrost is not enabled.

In general, the Desorbing CE pressure trigger will activate the phase transition when flow thru the JT is impeded. This occurs when:

- 1) the JT temperature is relatively high (e.g. during cooldown, and/or following the execution of the defrost procedure) and/or
- 2) the JT is plugged.

In both cases, this high impedance results in lower flow, which causes the HPST pressure to rise. When this is happening, the pressure limit is reached before the temperature and time limits.

The heatup and desorbing CE temperature limits come into play when the JT impedance is low, which happens when it is cold and unplugged. In this regime, the flow through the JT is greater than or equal to the flow out of the desorbing CE. In such cases, the desorbing CE desorbs all of its hydrogen and begins to deplete, at which point its temperature rises to the above-mentioned temperature limit.

The purpose of the maximum cycle time limit is solely to stabilize the compressor during low flow conditions (plugs and/or high JT temperatures). In these cases, it has been observed that the resulting cycle times can begin to oscillate. The maximum cycle time limit does not allow drastic oscillations.

Each time one of the above conditions is met and the phase switching occurs, the system undergoes two checks:

- a. If there might be the conditions for a JT plug (see next paragraph);
- b. If the system reached its nominal conditions (see end of this paragraph).



In case a) the Defrost process is activated, in case b) the system transitions into NORMAL State.

During the CONDITIONING operation, the LPSB is heated by the startup heater (40 W) following an ON-OFF (bang-bang) control, in order to keep the LPSB temperature within a predefined temperature range.

The CONDITIONING process requires that all the sensors of each compressor element operate properly, not allowing bad readings or bad sensors. More specifically, the CONDITIONING state depends heavily upon the bed thermocouples and bed pressure transducers. If either of these sensors fails, the corresponding bed must be removed from the CONDITIONING heating sequence (it will be reintegrated into cooler sequence once in NORMAL). The EBB cooler has been tested successfully using only 4 beds in the CONDITIONING state, showing a relatively high fault tolerance.

The Heatup and Desorption power values are different from the ones applied to the CE's in NORMAL operations, so they will have specific cells in the lookup table.

6.2.4.2. Defrost Process

JT plugs are one of the major risk factors of the Planck SCS and particular attention to this failure mode was paid in the design and realization of the system from both hardware and software point of view. It must be emphasized here that this plug removal procedure is not used to ensure safe cooler operation. Safe operation is ensured by the CONDITIONING procedure and the continuous monitoring of the system pressure and compressor element temperatures. The main issue of the Defrost process is the detection of a plug and autonomous removal to prevent long periods where the cooler can no longer provide heat lift. Since the cooler system does not include a flow meter, it is impossible to directly measure a decrease in the mass flow. Instead, the defrost procedure uses the bed cycle time to determine if the JT is plugged. When a plug occurs, gas flow out of the HPST will stop or decrease and the pressure will rise as the desorption bed evolves gas. The CONDITIONING Mode advances the cycle time when the high-pressure limit is reached and the cycle time will decrease as flow out the HPST is restricted or stopped. It is this decrease in cycle time that the defrost procedure uses for plug detection. In order to generate flow from a compressor element, enough energy must be deposited into the compressor element to heat it to the desorption pressure and maintain it there; thus mass flow can be related to energy deposited into the desorption compressor element. This is not the entire story as the procedure must be able to account for the strong temperature dependence of the JT flow impedance. To do this the procedure compares the deposited energy to a minimum energy limit equal to

- Begin with a CE at 260K containing a relatively low concentration of hydrogen
- Heat up the CE to the temperature at which its equilibrium pressure is 735psia (~460K)
- Desorb hydrogen gas at a rate equal to the nominal flow through the J-T for a pressure of 755 psia and a JT temperature of *MJT* (Max JT Temperature) for a period of 667 s.

This limit, called the Minimum Energy (*MINE*), is then compared to the actual deposited energy calculated as:

$$\text{Calculated Energy} = \text{HeatUp Power (for the current desorbing bed)} \times \text{last phase time} + \text{Desorbing Power (for the current desorbing bed)} \times \text{current phase time (1)}$$



Therefore, as the cycle time decreases, the deposited energy becomes less than the minimum energy. This first indication of a flow restriction has to be supported by the concurrence of other conditions that can be summarized in the following triggers:

- the Calculated Energy (1) is less than the Minimum Energy (MINE) **AND**
- the pressure in the tank is greater than Maximum Tank Pressure (MTP) **AND**
- the JT temperature is less than Maximum JT Temperature (MJT) **AND**
- the JT defrost checking is enabled **AND**
- the system is not already defrosting

If all these 5 conditions are met, the software perceives this status as a plug and activates the Defrost process by automatically energizing the JT and Particle filter heaters. This heater will stay ON for the required number of seconds (TBD) or until the JT valve reaches a pre-determined temperature. While the defrost heater is ON, the CONDITIONING process continues to run and prevents the system from transitioning to the NORMAL State.

After the plug/defrost check at the end of each cycle phase, the software examines the system conditions in order to inspect the possibility of a transition to NORMAL operation. This check consists in verifying that:

- the temperature of the JT is below the Maximum “Conditioning” JT temperature (MNJT),
- the hydrogen pressure in the High Pressure Tanks is within the acceptable range (defined by maximum and minimum Tank Pressure in CONDITIONING operation, minconTP and maxconTP),
- the system is not currently in Defrost.

If, or as soon as, these two conditions are verified at the end of a cycle phase, the system can transition into the NORMAL State.

In case one or more compressor elements were excluded from the CONDITIONING procedure because of bad readings or bad sensors, they must be reintegrated in the cycle when transitioning into NORMAL.

It has to be noted that after high purity gas recharge in FMs, no plug event has been recorded in any test campaign. For this reason, it is likely, at least in the early phases of the mission, that autonomous defrost detection will be disabled during operations.

6.2.4.3. NORMAL State

The **Normal** function is launched from CONDITIONING and it is the nominal operating mode of the system. This function drives the available beds (6, 5 or 4 beds) of the sorption cooler using a time-based cycle (6 phases of TBD seconds, with cycle time defined in the LUT), switching from phase to phase at the expiration of the constant phase-time. In any given phase, one sorbent bed is desorbing high-pressure gas while the others are heating, cooling, or re-absorbing low-pressure gas according to the scheme of Table 6-3.



Each bed is associated with 3 heaters (Heatup, Desorption and the Gas Gap Actuator) and goes through 4 different states (Heatup, Desorb, Cooldown and Absorb): each one of these states is associated with a unique configuration of these 3 heaters (see Fig.6.8).

Phase 1	Phase 2	Phase 3	Phase 4	Phase 5	Phase 6
Bed 1: HU	Bed 1: DE	Bed 1: GG	Bed 1: GG	Bed 1: GG	Bed 1: GG
Bed 2: DE	Bed 2: GG	Bed 2: GG	Bed 2: GG	Bed 2: GG	Bed 2: HU
Bed 3: GG	Bed 3: GG	Bed 3: GG	Bed 3: GG	Bed 3: HU	Bed 3: DE
Bed 4: GG	Bed 4: GG	Bed 4: GG	Bed 4: HU	Bed 4: DE	Bed 4: GG
Bed 5: GG	Bed 5: GG	Bed 5: HU	Bed 5: DE	Bed 5: GG	Bed 5: GG
Bed 6: GG	Bed 6: HU	Bed 6: DE	Bed 6: GG	Bed 6: GG	Bed 6: GG

HU: Heat-up; DE: Desorption; GG: Gas Gap Actuators ON

Table 6-3

The software applies adjustable power to the compressor element heaters during Heatup or Desorption phase to the appropriate bed for one cycle interval during operations. The power values are adjustable with a precision of 0.1 Watts. The lookup table contains all power values that can be up-linked by ground command. The software switches ON thermal switch heaters (Gas Gap Actuators) during Cooldown and Absorb: the switches are applied to the appropriate source compressor at the end of the Desorption time plus an adjustable time value ($\Delta T1$) provided on the lookup table. The software switches OFF the thermal switch heater applied to the appropriate source before the beginning of the Heatup phase plus an adjustable time value ($\Delta T2$) provided in the lookup table (see Fig.6.8).

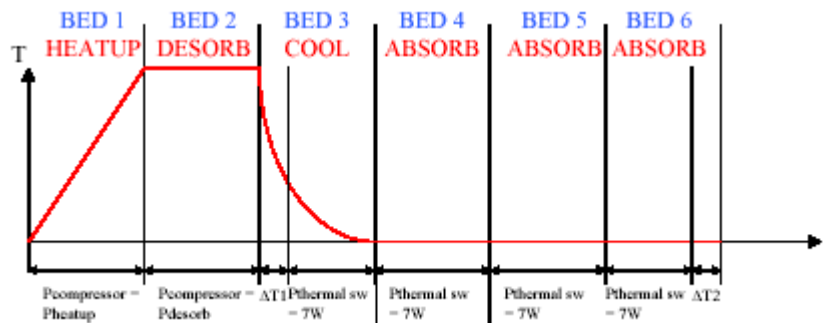

Figure 6-8 Description of a cycle in NORMAL operation

The diagram of Fig.5.8 shows an example of sequence for one CE:

- Phase 1: Heatup. Heatup heater is energized.
- Phase 2: Desorb. Desorption heater is activated.
- Phase 3: Cooldown. Bed heaters are switched OFF. GGA ON after an adjustable time delay ($\Delta T1$).
- Phase 4 and 5: Absorb. GGA ON.
- Phase 6: Absorb. GGA OFF prior to Heatup sequence for associated bed by an adjustable interval ($\Delta T2$).

During each of the 6 phases the software applies heat to the LPSB via the sustain heater and controls the TSA temperature using software PID control.



Values of the sensors are continuously compared with limit values in order to check for safety fault conditions. If a failure is encountered an alarm flag is raised and different types of scenarios can be manually or automatically activated according to the gravity of the error.

The system will proceed in its NORMAL State until:

- a) it is shutdown manually by the operator
- b) it is shutdown automatically by the occurrence of a serious fault
- c) the conditions of NORMAL State are exceeded, i.e.:
 - hydrogen pressure in the tank inside the normal range (defined by maximum and Minimum Tank Pressure in normal operation, minNTP and maxNTP)
 - CE temperature below first fault limit (defined by Maximum “normal” CE Temperature MNCET)
 - JT temperature below normal limit (defined by Maximum Normal JT temperature (MNJT))

If one condition of case c) is not valid, the relative triggers will push the system back to CONDITIONING State in order to resolve the detected problem.

The pressure range and the temperature limits that would send back the system to conditioning are different from the same parameters used in the transition between conditioning and normal (for stability reasons).

The cooler can operate in RUN Mode with 6, 5 or 4 beds: in Appendices A and B are respectively described the “bad bed detection procedure” and the “bed removal/addition procedure”.

6.2.4.4. SHUTDOWN MODE

From the functional point of view the SHUTDOWN Mode is equivalent to READY Mode (**without** Healthcheck): no power is supplied to the TMU and the cooler is continuously monitored. In case of a permanent Shutdown of the cooler it might useful (it does not affect the safety of the system) to leave the SCS in a condition of low pressure. In order to quickly depressurize the system, all the power should be removed and the beds should be connected to the Warm Radiator. Since it is not possible to energize all GGA at the same time, the TMU will be cycled with zero input power to the CE heaters for TBD cycles (usually 2 to 4 cycles are enough) of 667 s phases.

The shutdown mode is reached by the “GO TO Shutdown” telecommand from ready, run or shutdown modes. This mode can also be reached automatically when one of the following conditions is true:

- ▶ both ADC reading chains are bad.
- ▶ JT heaters H34 or H35 is always ON (detection in run mode only).



- ▶ Electronics temperature reached the second level limit (detection in run mode only).

Note: in all cases, the “switch off” event is also sent to CDMS.



7. Planck Sorption Cooler System Failures

7.1. TMU Failure Analysis

The full FMECA of the sorption cooler is presented in AD. The objective of the FMECA is to identify failure modes that could degrade or cause a loss of function to the cryocooler system; the FMECA also looked at failures that could potentially cause the loss of the satellite. This analysis does not encompass all of the interface issues between the sorption cooler and the satellite; only the mechanical interfaces are analyzed here. The entire set of interface issues, include control electronics and software, are analyzed in a separate analysis.

The critical items list in Table 7-1 describes the failures that could lead to satellite failure, loss of both cooler sides, and a single cooler loss. Although it may not seem critical if a single cooler is lost, for the purposes of this analysis they are labelled as critical due to the serious impact it will have on the mission. Losing a cooler side can affect everything from mission operation, dealing with safe modes, dealing with lost compressor elements or other components, available life on the system, and how to deal with anomalies; losing a cooler also adversely affects options available if a second type of failure occurs. Program management may want to have pre-developed operation plans for loss of cooler scenarios.

Losses of a compressor element or degraded performance are items that the satellite/cooler system can contend with in seamless fashion, and are thus not considered to be high risk items. This study does not consider scenarios in which “excessive” delays occur from failures or the system going into “safe” mode. The cooler system will have a limited lifetime, and if the system continually goes into “safe” mode, the amount of science time will be dramatically reduced. Every time the system goes into “safe” mode, the coolers are basically stopped, and there is at least a two week delay in obtaining science due to the time it takes to get the instruments back down to temperature. Considering that this system is only designed for 18 months on-orbit operation, two week shut downs may become over burdensome to the project, and a new fault protection plan may want to be developed.

Currently, most component failures just send the system into safe mode. For example, most sensors are single string, and when one fails, it usually results in the system going into safe mode since there is no voting scheme available. Additionally, most hardware failures will also put the system in “safe” mode, even though there is no inherent risk to the satellite; this merely allows the ground personnel to make the decision of what to do next instead of having an automated fault tolerance system. However, two-week shutdowns are the price that is being paid for allowing people to make all the decisions.

Although there appear to be many items on the Critical Item List, the list as a whole can be broken down into various parts. The Joule-Thompson (J-T) throttle valve is susceptible to several modes of failure. It operates at very low temperatures, and there is concern that frozen particles, such as methane, could clot the J-T and prevent system flow. To mitigate this, there are many filters throughout the cooler designed to trap these particulates. Secondly, the system is being flushed to reduce the carbon compounds to an absolute minimum. Third, there is a heater designed to turn frozen particles into liquid. Finally, the J-T is a Mott device with many internal flow paths, making clogging a less likely occurrence.

There are many heaters within the system, such as those on the compressor elements designed to heat the beds, the 10 W and 40 W heaters on the Low Pressure Stabilization Bed



and the J-T heater. If a heater fails “off,” it usually results in decreased performance since the corresponding compressor element or LPSB will be inoperable. If the J-T heater fails “off” it becomes more susceptible to particulate contamination, and without the heater, it may be fatal to the cooler. Similarly, if the filter heater should fail “off,” it too represents a potential flow blockage scenario.

A heater failing “on” presents a more critical scenario, because it could result in a complete loss of cooler due to inability to control the flow. The system has been designed, however, to be able to withstand the pressures created by the available heating given that any or all heaters fail in the “on” position, thereby reducing the risk of rupture to a minimum.

Leaks appear to be the predominant path to losing a cooler. With over 150 welds within the system, there are many potential leak paths. However, many welds will be subjected to Non-Destructive Examination testing and will be performed under controlled conditions, thereby reducing this risk as much as possible. It is unknown how the hydride would react with materials within the satellite system, such as electronics, wire insulations, thermal insulations, etc., and potentially cause a dangerous situation. However, it is assumed that all precautions have been considered by the satellite design team and that this threat too has been reduced as much as possible. Furthermore, the compressor elements and assemblies undergo extensive NDE during buildup and all undergo leak checks prior to shipping.

Should any of the physical supports fail during launch, there is the potential of creating debris within the cooler and/or satellite. Some of the components are heavy enough to cause significant damage to both the cooler and satellite. However, the safety margins and QA procedures that are used when designing and installing component fixtures are there to reduce this risk to a minimum as well.

There is a lot of cabling and wiring within the system. This could be damaged by human interactions, Micro-Meteoroid Orbital Debris (MMOD), hazardous fluids, vibration environments, etc. When wires become damaged, they may open, short or even cross. These types of scenarios may result in a loss of cooler operation with no ability to mitigate the failures except for switching to the redundant cooler if it has not been affected. Failures of this type may also affect the satellite functionality, but are beyond the scope of this analysis.

The purge and fill valves are potential leak sources of the system as well. Even if they are welded closed, the valve body, weld and associated hardware may present a flow path. These scenarios are similar to the leak scenarios in which the hydride from the system is lost, and the cooler is inoperable. There is currently no means to mitigate hydrogen leaks outside the system. However, all of the hardware, valves, and welds will be qualified to the appropriate environment to reduce this risk to an absolute minimum.

The last critical item is the potential failure modes of the radiator. Although it is not JPL’s responsibility, it should be noted that the functionality of this item is critical to successful cooler operation. If the spacecraft has thermal control problems due to design or control issues, the radiators and cooler system could experience excessive temperatures. The radiators could also delaminate since the composite sheets experience large changes in temperatures. As with every other piece of hardware in the system, the welds around the radiator and within the radiator are all potential leak paths. It is assumed that Alcatel and its contractors have the appropriate design and testing standards in place to mitigate these failures. This issue, as well as other interface issues, will be discussed in more detail in the Interface FMECA which is currently under development.



It should be noted that there are two coolers on the satellite, each capable of providing cooling. If one should fail during the mission, the other could pick up the load and the mission could continue to the end. Each cooler is designed for the life expectancy of the entire mission.

There are many failures listed in the FMECA that result in either degraded science or going to safe mode. Although "safe" mode is designed to prevent damage to the system, it needs to be stated that every time the system goes into "safe" mode, there will be a serious time delay on the order of weeks. If the system goes into "safe" mode too frequently, this will have a serious impact on the science mission considering the interruption and the life issues of the system. The program may want to consider more intelligent "work-around" and reasons for going into "safe" mode to prevent excessive use of this mode.



ITEM	MISSION PHASE	FAILURE MODES	POSSIBLE CAUSES	COOLER EFFECT	PLANCK EFFECT	FAILURE DETECTION	PROB	CRIT
Compressor Element Assy								
Manifold Assy	Operational, Regeneration	Leak at inlet or exhaust	Weld failure, cracks	Loss of cooler	Science loss	Temperature and pressure readings; no pumping force, no cooling	Low	Med
		Leak into outer tube assy	Weld failure, cracks	Loss of compressor element	Degraded performance	Temperature and pressure readings, no pumping force, no cooling, collateral damage	Low	Med
Inner Tube Assy	Operational, Regeneration	Leak at inlet or exhaust	Weld failure, cracks	Loss of cooler	Science loss	Temperature and pressure readings; no pumping force, no cooling	Low	Med
		Leak into outer tube assy	Weld failure, cracks	Loss of compressor element	Degraded performance	Temperature and pressure readings, no pumping force, no cooling, collateral damage	Low	Med
Outer Tube Assy	Operational, Regeneration	Leak into gas gap	Weld failure, cracks	Loss of compressor element	Science loss	Temperature and pressure readings; no pumping force, no cooling	Low	Med
		Overpressure	Leak from manifold or inner tube assy	Flood gas gap with H2	Degraded performance	Temperature and pressure readings, no pumping force, no cooling, collateral damage	Low	Med
Heat switch volumes	Operational, Regeneration	H2 gas generation in gas gap volume overcoming storage capacity of getter alloy	Outgassing from electroplated Au/Ni films & H2 permeation through heated inner bead	Reduced efficiency due to increasing thermal parasitic heat loss	Degraded performance leading to accelerated end of life	Excessive Power consumption, system pressure and readings	High	Low
Front support	Launch	Structural Failure	Installation error, launch load stress	Loss of compressor element	Degraded performance	No pumping force, loss of cooling, loss of experiment, or loss of satellite	Low	High



ITEM	MISSION PHASE	FAILURE MODES	POSSIBLE CAUSES	COOLER EFFECT	PLANCK EFFECT	FAILURE DETECTION	PROB	CRIT
Thermocouple	Operational	No signal	Open circuit	None	Possible compressor element deactivated	Thermocouple readings and/or history	Low	Low
		False reading	Circuit malfunction, miscalibration, contamination	None	Possible compressor element deactivated	Thermocouple readings and/or history	Low	Low
	Regeneration	No signal	Open circuit	None	Inability to regenerate hydride bed	Thermocouple readings and/or history	Low	Low
		False reading	Circuit malfunction, miscalibration, contamination	None	Inability to regenerate hydride bed	Thermocouple readings and/or history	Low	Low
Rear support	Launch	Structural Failure	Installation error, launch load stress	Loss of compressor element	Degraded performance	No pumping force, loss of cooling, loss of experiment	Low	High
Hydride	Operational	Degradation	Life, contamination	Loss of compressor element	Degraded performance	May be difficult to determine if hydride has deteriorated; many possibilities of other failures that could lead to loss of compressor element	Low	Med
Heater Assy	Operational	Fail On	Short circuit, control failure	Loss of cooler	Switch to backup cooler	No pumping force, loss of cooling, loss of experiment, excessive power drain	Low	Med
		Fail Off	Fail open, control failure	Loss of compressor element	Degraded performance	No pumping force, loss of cooling	Low	Med
	Regeneration	Fail On	Short circuit, control failure	Loss of cooler	Switch to backup cooler	No pumping force, loss of cooling, loss of experiment, excessive power drain	Low	Med
		Fail Off	Fail open, control failure	Inability to regenerate hydride bed	Degraded performance	Degraded performance	Low	Med



Planck LFI
Sorption Cooler System
User Manual

Document No.: PL-LFI-PST-MA-002
 Issue/Rev. No.: 3.0
 Date: 20 March 2009

ITEM	MISSION PHASE	FAILURE MODES	POSSIBLE CAUSES	COOLER EFFECT	PLANCK EFFECT	FAILURE DETECTION	PROB	CRIT
Outer Tube Assy to Radiator Bolted Interface	Launch	Structural Failure	Fastener overstress, installation error, corrosion	Loss of compressor element	Spacecraft loss	No pumping force, loss of cooling, loss of experiment, or loss of satellite	Low	High
Low Press Stabilization Bed								
Manifold Assy	Operational, Regeneration	Leak	Weld failure, cracks	Loss of cooler	Switch to backup cooler	Temperature and pressure readings	Low	Med
Inner Tube Assy	Operational, Regeneration	Leak	Weld failure, cracks	Loss of cooler	Switch to backup cooler	Temperature and pressure readings	Low	Med
Heater Assy (10 w)	Operational, Regeneration	Fail On	Short circuit	Degraded performance from rising cold end temperature due to rise in back pressure on liquid hydrogen	Switch to backup cooler	Raise system pressure and transfer more hydrogen in to CE and HPST	Low	Med
		Fail Off	Open circuit	Degraded performance	Degraded performance	No pumping force, loss of cooling	Low	Med
Heater Assy (40 w)	Startup, Regeneration	Fail On	Short circuit	Degraded performance from rising cold end temperature due to rise in back pressure on liquid hydrogen	Switch to backup cooler	Raise system pressure and transfer more hydrogen in to CE and HPST	Med	Med
		Fail Off	Open circuit	Degraded performance	Degraded performance	No pumping force, loss of cooling	Low	Med
Thermocouple	Operational, Regeneration	No signal	Open circuit	None	Potential Switch to backup cooler	Thermocouple readings and/or history	Low	Med



ITEM	MISSION PHASE	FAILURE MODES	POSSIBLE CAUSES	COOLER EFFECT	PLANCK EFFECT	FAILURE DETECTION	PROB	CRIT
		False reading	Circuit malfunction, miscalibration, contamination	None	Potential Switch to backup cooler	Thermocouple readings and/or history	Low	Low
LPSB to Compressor Assembly Interface	Launch	Structural failure	Fastener overstress, installation error, corrosion	Loss of compressor element	Possible loss of spacecraft	No pumping force, loss of cooling, loss of experiment, or loss of satellite	Low	High
Gas Gap Actuation Sys								
Tube end cap	Operational, Regeneration	Leak	Weld failure, cracks	Loss of compressor element	Degraded performance	No pumping force, no cooling, excessive power drain	Low	Med
Hydride Disc	Operational	Degradation	Disproportionation	Loss of compressor element	Degraded performance	No pumping force, no cooling, excessive power drain	Low	Med
	Regeneration	Degradation	Disproportionation	Loss of compressor element; inability to regenerate bed	Degraded performance	No pumping force, no cooling, excessive power drain	Low	Med
Porous Disc Filter	Launch	Structural Failure	Random vibe	Loss of compressor element	Degraded performance	None until startup	Low	Med
	Operational	Blockage	Contamination	Loss of compressor element; inability to regenerate hydride bed	Degraded performance	No pumping force, no cooling, excessive power drain	Low	Med
	Regeneration	Blockage	Contamination	Loss of compressor element; inability to regenerate hydride bed	Degraded performance	No pumping force, no cooling, excessive power drain	Low	Med
Actuator Hydride Heater	Operational	Fails On	Short circuit, control failure	Loss of actuator function	Loss of compressor element	Degraded performance	Med	Med



ITEM	MISSION PHASE	FAILURE MODES	POSSIBLE CAUSES	COOLER EFFECT	PLANCK EFFECT	FAILURE DETECTION	PROB	CRIT
		Fails Off	Fail open, control failure	Loss of actuator function	Loss of compressor element	Degraded performance	Med	Med
	Regeneration	Fails On	Short circuit, control failure	Inability to return to operational mode (compressor element)	Loss of compressor element	Degraded performance	Med	Med
		Fails Off	Fail open, control failure	Inability to regenerate hydride bed (compressor element)	Loss of compressor element	Degraded performance	Med	Med
Compressor Assembly								
High Press Stab Tank Assy	Launch	Leak	Launch loads	Loss of cooler	Switch to backup cooler	No pumping force, loss of cooler	Low	Med
	Operational, Regeneration	Leak	Overpressure, corrosion	Loss of cooler	Switch to backup cooler	No pumping force, loss of cooler	Low	Med
HPST Bolted Interfaces	Launch	Structural failure	Fastener overstress, installation error, corrosion	Loss of cooler	Switch to backup cooler	No pumping force, loss of cooling	Low	Med
Check Valves	Operational, Regeneration	Fails Open	Valve failure, particulate contamination	Degraded performance	Degraded performance	No pumping force, no cooling, excessive power drain	Low	Med
		Fails Closed	Valve failure, frozen, contamination	Loss of compressor element	Degraded performance	No pumping force, no cooling, excessive power drain	Low	Med
Purge and Fill Valves	Operational, Regeneration	Leak	Valve failure	Loss of cooler	Switch to backup cooler; possible loss of satellite due to unknown interaction with hydride and critical equipment	No pumping force, loss of cooling	Low	Med



ITEM	MISSION PHASE	FAILURE MODES	POSSIBLE CAUSES	COOLER EFFECT	PLANCK EFFECT	FAILURE DETECTION	PROB	CRIT
Pressure Transducers	Operational, Regeneration	No signal	Open circuit	None	Potential Switch to backup cooler	Sensor monitoring (over time) and system level operation	Low	Low
		False pressure reading	Circuit malfunction, miscalibration, installation error	None	Potential Switch to backup cooler	Sensor monitoring (over time) and system level operation	Med	Low
In-Line Gas Filters	Operational, Regeneration	Blockage	Particle contamination, filter breakup	Loss of compressor element	Degraded performance	Degraded performance, reduced flow	Low	Med
Manual CE Isolation Valves	Operational, Regeneration	Closed	Pre-launch human error	Loss of compressor element	Degraded performance	Loss of cooling	Low	Med
Pipe Welds (orbital tube welds except for one)	Launch	Structural Failure	Random vibrate	Loss of cooler	Switch to backup cooler	None until startup for compressor element; if leak affects satellite, effects would be seen during spacecraft power up	Low	Med
	Operational, Regeneration	Structural Failure	Contamination, Overpressure, H2 embrittlement	Loss of cooler	Switch to backup cooler	Loss of cooling, possible loss of satellite depending upon leak effects	Low	Med
		Leak	Overpressure, H2 embrittlement	Loss of cooler	Switch to backup cooler	Loss of cooling, possible loss of satellite depending upon leak effects	Low	Med
Control Electronics	Operational, Regeneration	Malfunction, Power reboot	Spacecraft interface, power problem, short or open circuit, fluid leaks	Loss of Primary and Redundant Coolers	Mission Loss	Many detection methods, but may be difficult to isolate the true cause	Low	High
Piping								
Counterflow Heat Exchanger 1	Operational, Regeneration	Leak	Weld failure, cracks	Loss of cooler	Switch to backup cooler	Proof test, temperature and pressure readings, no cooling	Low	Med
Precooler 1	Operational, Regeneration	Leak	Weld failure, cracks	Loss of cooler	Switch to backup cooler	"	Low	Med



Planck LFI
Sorption Cooler System
User Manual

Document No.: PL-LFI-PST-MA-002
 Issue/Rev. No.: 3.0
 Date: 20 March 2009

ITEM	MISSION PHASE	FAILURE MODES	POSSIBLE CAUSES	COOLER EFFECT	PLANCK EFFECT	FAILURE DETECTION	PROB	CRIT
Counterflow Heat Exchanger 2	Operational, Regeneration	Leak	Weld failure, cracks	Loss of cooler	Switch to backup cooler	"	Low	Med
Precooler 2	Operational, Regeneration	Leak	Weld failure, cracks	Loss of cooler	Switch to backup cooler	"	Low	Med
Cabling	Operational, Regeneration	Short, open	Physical damage, overstress, component failure	Loss of cooler	Switch to backup cooler	"	Low	Med
Counterflow Heat Exchanger 3	Operational, Regeneration	Leak	Weld failure, cracks	Loss of cooler	Switch to backup cooler	"	Low	Med
Precooler 3	Operational, Regeneration	Leak	Weld failure, cracks	Loss of cooler	Switch to backup cooler	"	Low	Med
Counter Flow Heat Exchanger 4	Operational, Regeneration	Leak	Weld failure, cracks	Loss of cooler	Switch to backup cooler	"	Low	Med
Charcoal Filter	Operational, Regeneration	Blockage, filter breakup	Contamination, constriction	Increased likelihood of plugging of J-T Expander; loss of cooler or interrupted operation	Switch to backup cooler	Pressure rise (as per blocked J-T Expander)	Low	Med
Cold End								
Liquid Vapor Heat Exchanger 1	Operational, Regeneration	Leak	Weld failure, cracks	Loss of cooler	Switch to backup cooler	Loss of cooler	Low	Med
Liquid Vapor Heat Exchanger 2	Operational, Regeneration	Leak	Weld failure, cracks	Loss of cooler	Switch to backup cooler	Loss of cooler	Low	Med
Liquid Vapor Heat Exchanger 3	Operational, Regeneration	Leak	Weld failure, cracks	Loss of cooler	Switch to backup cooler	Loss of cooler	Low	Med



ITEM	MISSION PHASE	FAILURE MODES	POSSIBLE CAUSES	COOLER EFFECT	PLANCK EFFECT	FAILURE DETECTION	PROB	CRIT
Particle filter (0.01 Mic)	Operational, Regeneration	Blockage, Filter breakup	Contamination	H2 gas pressure buildup, decreased cooling	Interrupted operation	Increased pressure, degraded performance	Low	Med
Particle Filter Heater	Operational, Regeneration	Fails On	Circuit malfunction	Heat input into cold end renders cooler inoperable	Instrument function may be completely degraded if power cannot be removed from this heater	Increased system pressure is detected, causing shutdown of compressor.	Low	High
		Fails Off	Open circuit	Potential Filter Blockage	Potential cooler loss	Increased pressure, degraded performance	Low	High
Joule-Thompson Expansion Device	Operational, Regeneration	Blockage, Filter breakup	Particulate contamination or blockage	H2 gas pressure buildup	Interrupted operation	Increased pressure, degraded performance	Low	Med
JT Heater	Operational, Regeneration	Fails On	Circuit malfunction	Heat input into cold end renders cooler inoperable	Instrument function may be completely degraded if power cannot be removed from this heater	Increased system pressure is detected, causing shutdown of compressor.	Low	High
		Fails Off	Open circuit	Potential blockage of Mott device, with H2 gas pressure buildup	Potential cooler loss	Increased pressure, degraded performance	Low	High
LVHX1 Temp Sensor	Operational, Regeneration	No signal	Open circuit	None	No effect	Sensor monitoring (over time) and system level operation	Low	Nil
		False temperature reading	Circuit malfunction, miscalibration, contamination	None	No effect	Sensor monitoring (over time) and system level operation	Low	Nil
LVHX2 Temp sensor	Operational, Regeneration	No signal	Open circuit	None	No effect	Sensor monitoring (over time) and system level operation	Low	Nil



ITEM	MISSION PHASE	FAILURE MODES	POSSIBLE CAUSES	COOLER EFFECT	PLANCK EFFECT	FAILURE DETECTION	PROB	CRIT
		False temperature reading	Circuit malfunction, miscalibration, contamination	None	No effect	Sensor monitoring (over time) and system level operation	Low	Nil
LVHX3 Temp sensor	Operational, Regeneration	No signal	Open circuit	None	No Effect	Sensor monitoring (over time) and system level operation	Low	Low
		False temperature reading	Circuit malfunction, miscalibration, contamination	None	No Effect	Sensor monitoring (over time) and system level operation	Low	Low
Interfaces								
Compressor Element Radiator	Operational, Regeneration	Delamination	High Delta-Temp at CE interface	Loss of cooler	Switch to backup cooler	No pumping force, loss of cooling	Low	Med
		Overtemp	Spacecraft thermal control malfunction, S/C orientation	Loss of cooler	Switch to backup cooler	Temperature and pressure readings, reduced capability	Low	Med
	Operational	Heat transfer between adjacent CEs	Finite radiator thermal mass	Degraded performance	Science loss	No pumping force, loss of cooling	Low	Low
	Regeneration	Heat transfer between adjacent CEs	Finite radiator thermal mass	Unable to regenerate hydrides	Degraded performance	No pumping force, loss of cooling	Low	Low
Wiring	Operational, Regeneration	Fail open or short	Wire chafing, installation errors, cold flow (Teflon), mechanical stress	Loss of cooler	Switch to backup cooler; possible unknown interactions with satellite or control issues	Many, including loss of power, loss of control, faulty readings, etc., but may be difficult to isolate	Low	High
HX/LVHX to Instrument Bolted Interface	Launch	Structural failure	Fastener overstress, installation error, corrosion	Loss of cooler	Switch to backup cooler	Loss of cooling, possible collateral damage	Low	Med

Table 7-1. TMU FMECA Table



7.2. SCE Failure Analysis

7.2.1. SCE FMECA

The SCE Failure Analysis indicates the most critical items producing the most severe effect on their failure modes. A redundant design for these components will normally increase the reliability of the system. But, it should be noted that the analysis presented here does not take into account the fact that the Sorption Cooler Subsystem is fully redundant including electronics. So, in a certain way, the critical parts listed before are fully redundant.

In conclusion, the severity of the failure effects will decrease of one level due to this redundancy and no effect will be higher than Critical if we consider the two electronics. Therefore, the chosen components and design are presenting enough reliability to prevent the loss of the mission under catastrophic scenarios.



ID #	Item Description	Function Description	Failure Mode	Most Probable cause	Failure Effect on			Severity	Failure Mode Detection	Remarks
					SCE	SCS	Planck			
1	PLDBA0 Data Processing & communication	S/C Communication	No communication	1553b Controller Failure	SCE Inoperable	SCS Inoperable	Science Loss	I. Catastrophic	S/C watch dog	Switch to redundant SCS
2		S/C Data reading	No reading	1553b Controller Failure	SCE Inoperable	SCS Inoperable	Science Loss	I. Catastrophic	Internal Diagnostics	Switch to redundant SCS
3			Wrong reading	1553b Controller Failure	SCE Inoperable	SCS Inoperable	Science Loss	I. Catastrophic	Internal Diagnostics	Switch to redundant SCS
4		Data writing to S/C	No writing	1553b Controller Failure	SCE Inoperable	SCS Inoperable	Science Loss	I. Catastrophic	S/C watch dog	Switch to redundant SCS
5			Wrong writing	RAM Failure	SCE Inoperable	SCS Inoperable	Science Loss	I. Catastrophic	S/C watch dog	Switch to redundant SCS
6		Data storing	Storing failure	RAM Failure	SCE Inoperable	SCS Inoperable	Science Loss	I. Catastrophic	Internal Diagnostics	Switch to redundant SCS
7		Sequencing	No sequencing	DSP Failure	SCE Inoperable	SCS Inoperable	Science Loss	I. Catastrophic	Internal Diagnostics	Switch to redundant SCS
8			Sequencing unstable	Timer Failure	Run Mode inoperable	SCS operable "Manually"	Science Loss	II Critical	Internal Diagnostics	Switch to redundant SCS
9		Sequence parameters reading	No updated parameters	RAM Failure	Look Up Table non updateable	SCS non adjustable	Science Loss	II Critical	Internal Diagnostics	Switch to redundant SCS
10		Sequences control	Non sequence control	Timer Failure	Run Mode inoperable	SCS operable "Manually"	Science Loss	II Critical	Internal Diagnostics	Switch to redundant SCS
11		Internal diagnostics	No diagnostics	FPGA Failure	SCE Inoperable	SCS uncontrollable	Science Loss	I. Catastrophic	HK Data Analysis	Switch to redundant SCS
12		Cooler diagnostics	No or wrong data read	FPGA Failure	SCE Inoperable	SCS uncontrollable	Science Loss	I. Catastrophic	HK Data Analysis	Switch to redundant SCS
13			No or wrong data written	FPGA Failure	SCE Inoperable	SCS uncontrollable	Science Loss	I. Catastrophic	HK Data Analysis	Switch to redundant SCS
14		LR3 regulation	No regulation	DSP Failure FPGA Failure	LR3 uncontrollable	Temperature Fluctuation	Science Loss	II Critical	Cooler diagnostics	Switch to redundant SCS

Table 7-2 SCE data processing and communication FMEA



7.2.2. Sensor Acquisition (PLDBB0) FMEA

ID #	Item Description	Function Description	Failure Mode	Most Probable cause	Failure Effect on			Severity	Failure Mode Detection	Remarks
					SCE	SCS	Planck			
15	PLDBB0 Sensors Acquisition	Sensors Amplification	No or Wrong signal	Amplifier Failure	Sensor channel unavailable	Sensor Value unavailable	Delay in Science data	III. Marginal	Internal Diagnostics	Switch to redundant Sensor if exist
16		Temp Sensors excitation	No or Wrong signal	Amplifier or Active Switch Failure	No Temp. Sensors available	Temps Sensors unavailable	Science Loss	I. Catastrophic	Internal Diagnostics	Switch to redundant SCS
17		Sensors Multiplexing	No or Wrong Sensor	Multiplexor Failure	Some Sensor channel unavailable	Some Sensor Value unavailable	Delay in Science data	III. Marginal	Internal Diagnostics	Switch to redundant acquisition channel
18		Sensors Digitalization	No or Wrong Digitalization	Amplifier or ADC Failure	No Sensors available	No Sensors value available	Delay in Science data	III. Marginal	Internal Diagnostics	Switch to redundant acquisition channel

Table 7-3 Sensor Acquisition

7.2.3. Power Handling (PLDBC0) FMEA

ID #	Item Description	Function Description	Failure Mode	Most Probable cause	Failure Effect on			Severity	Failure Mode Detection	Remarks
					SCE	SCS	Planck			
19	PLDBC0 Power Handling (Power Supply)	Voltage conversion	No or Wrong Voltage (+5, +15, -15)	DC/DC Failure (+5, +15, -15)	SCE Inoperable	SCS Inoperable	Science Loss	I. Catastrophic	S/C watch dog	Switch to redundant SCS
20			No or Wrong Voltage (+12 Th, Sw)	DC/DC Failure (+12 Th, Sw)	SCE Inoperable	SCS Inoperable	Science Loss	I. Catastrophic	Internal Diagnostics	Switch to redundant SCS
21			No or Wrong Voltage (+12 Heaters)	DC/DC Failure (+12 Heaters)	SCE Inoperable	SCS Inoperable	Science Loss	I. Catastrophic	Internal Diagnostics	Switch to redundant SCS
22	PLDBC0 Power Handling (Heaters Control)	Digital to analog conversion	No or wrong conversion	DAC Failure	SCE Inoperable	SCS Inoperable	Science Loss	I. Catastrophic	Internal Diagnostics	Switch to redundant SCS
23			No or wrong conversion On LR3	DAC Failure	No LR3 Regulation	Temperatures variations	Science Loss	III. Marginal	Internal Diagnostics	Switch to redundant LR3 heater



ID #	Item Description	Function Description	Failure Mode	Most Probable cause	Failure Effect on			Severity	Failure Mode Detection	Remarks
					SCE	SCS	Planck			
24		Fixed Power providing	No power available	Active Switch of Trans. Failure	SCE in off-Normal or Inoperable	SCS in off-Normal or Inoperable	Science Loss	II Critical	Internal Diagnostics	Suppress one compressor or Switch to redundant SCS
25			Permanent Power	Active Switch of Trans. Failure	SCE in off-Normal or Inoperable	SCS in off-Normal or Inoperable	Science Loss	II Critical	Internal Diagnostics	Suppress one compressor or Switch to redundant SCS
26		Regulated Power providing	No power available	Active Switch of OpA. Failure	SCE in off-Normal or Inoperable	SCS in off-Normal or Inoperable	Science Loss	II Critical	Internal Diagnostics	Suppress one compressor or Switch to redundant SCS
27			No adjustment possible	Active Switch of OpA. Failure	SCE in off-Normal or Inoperable	SCS in off-Normal or Inoperable	Science Loss	II Critical	Internal Diagnostics	Suppress one compressor or Switch to redundant SCS

Table 7-4 SCE power handling FMEA

Note: Severity Classification.

I – Catastrophic = A failure which may cause system loss.

II – Critical = A failure which may cause major system damage which will result on mission loss.

III – Marginal = A failure which may cause minor system damage which will result in delay or loss of availability.

IV – Minor = A failure not serious enough to cause system damage but which will result in unscheduled repair.

7.2.4. SCE components critical analysis

ID #	ITEM	Function	Failure Mode ID#	Severity Class	Failure Effect Probability ()	Failure Mode Ratio ()	Failure Rate (λ p)	Operating Time (t=hours)	Failure Mode Criticality (Cm)	Item Criticality (Cr)	Remarks
1	1553b Controller	1553b Comm.	1	I. Catastrophic	0.5	0.25	0.050	26280	164.25	657	
			2	I. Catastrophic	0.5	0.25			164.25		
			3	I. Catastrophic	0.5	0.25			164.25		
			4	I. Catastrophic	0.5	0.25			164.25		
2	RAM	Memory	5	I. Catastrophic	0.5	0.4	0.008		42.05	86.2	
			6	I. Catastrophic	0.5	0.4			42.05		
			9	II Critical	0.05	0.2			2.10		
3	DSP	Processing	7	I. Catastrophic	1	0.8	0.284		5970.82	6120.1	
			14	II Critical	0.1	0.2			149.3		
4	Timer	Timing	8	II Critical	0.5	0.5	0.019		124.83	249.7	



ID #	ITEM	Function	Failure Mode ID#	Severity Class	Failure Effect Probability ()	Failure Mode Ratio ()	Failure Rate (λ p)	Operating Time (t=hours)	Failure Mode Criticality (Cm)	Item Criticality (Cr)	Remarks
5	FPGA	Logical Functions	10	II Critical	0.5	0.5	0.179		124.83	4280.8	
			11	I. Catastrophic	1	0.3			1411.24		
			12	I. Catastrophic	1	0.3			1411.24		
			13	I. Catastrophic	1	0.3			1411.24		
			14	II Critical	0.1	0.1			47.04		
6	Amplifier	Sensors amplification	15	III. Marginal	0.05	0.2	0.034		8.94	366.4	
			16	I. Catastrophic	0.5	0.6			268.06		
			18	III. Marginal	0.5	0.2			89.36		
7	Amplifier	Other amplif.	16	I. Catastrophic	0.5	1	0.030		394.2		
8	Active Switch	Bias switch	16	I. Catastrophic	0.5	1	0.014		183.96	184.0	
9	Multiplexor	Bias routing	17	III. Marginal	0.05	1	0.019		24.97	25.0	
10	ADC	Digitalization	18	III. Marginal	0.05	1	0.023		30.23	30.2	
11	DC/DC	5 & 15V conv.	19	I. Catastrophic	1	1	0.130		3416.40	3416.4	
12	DC/DC	12V voltage conversion	20	I. Catastrophic	1	0.5	0.125		1642.50	3285.0	
			21	I. Catastrophic	1	0.5			1642.50		
13	DAC	Digital to analog conv.	22	I. Catastrophic	1	0.5	0.014		183.96	193.2	
			23	III. Marginal	0.05	0.5			9.20		
14	Active Switch / Trans.	Power control	24	II Critical	0.5	0.25	0.230		755.55	3022.2	
			25	II Critical	0.5	0.25			755.55		
			26	II Critical	0.5	0.25			755.55		
			27	II Critical	0.5	0.25			755.55		
15	Op Amp (OpA)	Driver	26	II Critical	0.5	0.5	0.030		197.10	394.2	
			27	II Critical	0.5	0.5			197.10		

Table 7-5 SCE critical analysis table



7.2.5. Critical Analysis conclusions

The Critical Analysis indicates the most critical items producing the most severe effect on their failure modes. Those components are typically the DSP, FPGA and the DC/DC converter. A redundant design for these components will normally increase the reliability of the system. But, it should be noted that the analysis presented here does not take into account the fact that the Sorption Cooler Subsystem is fully redundant including electronics. So, in a certain way, the critical parts listed before are fully redundant.

In conclusion, the severity of the failure effects will decrease of one level due to this redundancy and no effect will be higher than Critical if we consider the two electronics. Therefore, the chosen components and design are presenting enough reliability to prevent the loss of the mission under catastrophic scenarios.



7.3. SCE HW and SW Interaction analysis (HSIA)

The HSIA reported here consider the interaction between the SCE software and the TMU. The failures modes taken into account are relatives to the entire Sorption Cooler Subsystem.

The following information shall be considered for each failure mode:

- Symptoms triggering the software actions.
- Actions of the software (failure isolation and recovery)
- Effect of the software actions on the product functionality (SCS).

7.3.1.1. Philosophy

The Fault Detection Isolation and Recovery (FDIR) system implemented in the SCE software must permit the system to respond automatically in case of failures detected in respect of the following philosophy:

- Keep the system in a safety state for itself, the instrument and the spacecraft.
- Reduce to the minimum the losses of cooling power in case of failure until the next command window.
- Record all the needed information on the system, allowing the users (ground) to take the best decision in case of major failure.

7.3.1.1.1. Failures descriptions

The new version of the Start Up process to be implemented in the SCE software is now completely based on the sensors values instead of time steps. All the software actions, including the isolation and recovery actions are triggered with sensors values. Consequently, the criticality of the sensors and their reading chain (multiplexers, amplifiers and ADC) is now higher. The SCE software must be able to determine in an accurate way the failures of the sensors reading chain and to enunciate it in a status word or a flag.

First of all, more than one references resistor must be implemented in the electronics to be able to read references values with the reading chain, allowing the system to identify the failures on this part.

Obviously, the sensor failure identification and recovery can be possible also because there are two independent electronics reading chain (including ADC) implemented in the SCE. In case of a loss of one reading chain, the sensor failure identification is no longer possible so every anomaly detected in sensors reading value will conclude to a sensor failure and initiate the defined action.

7.3.1.1.2. Software Action on Failures (SCE internal FDIR)

All the failure described here will trigger action only on the SCE OBSW. No action is requested on the CDMS.

7.3.1.1.3. Reading chain failures

For the sensors reading chain, the following failure modes have been identified:



ID#	Failure Mode	Symptom Trigger	Detection Method	Recovery	SCE Software Action		Comments
1	ADC failure	Discrepancy in the values between the two reading chains	Comparison between the references channels on the two reading chains. The two values must be identical	Yes (Only once)	If the second reading chain is available, the system will use the values provided by the second chain	If the second reading chain is not available, perform actions described in sensor failure table If the second reading chain is not available, go to Shutdown Run Modes not reachable	RECOVERY POSSIBLE BY SWITCHING TO THE REDUNDANT READING CHAIN

Table 7-6

For this failures, a Flag (Set_Device_State) will be set to indicate a failure on the considered reading chain.

7.3.1.1.4. Sensors Failures

No automatic algorithm for failure detection on sensors will be implemented in the SW. The failure detection is done by the operator on ground. A failed sensor can be declared bad by sending the **Set_Device_State** command, turning “bad” the state flag of the considered sensor. The SCE SW actions described below are triggered by these flags.

7.3.1.1.5. Beds

ID#	Failure on:	Operating mode	Isolation	Recovery	SCE Software Actions		Effect on SCS
1	Bed Thermocouples T20 to T25	Run/Start Up & Run/Defrost	Yes	Yes ¹	- Initiate 5 (or 4) bed operation if possible, if already in 4 bed mode, go to Ready mode. - Enunciate failure in HK		- SCS running in degraded mode ² - Temperature increase
		Run/Normal	Yes	Yes ¹	- Eventually reinsert the bed suppressed in Start Up. - Enunciate failure in HK		- SCS running from degraded mode to nominal mode
					- Enunciate failure in HK		- No effects
2	Bed PRT T15, T16 & T26 to T29	Run	Yes	No	- If loss of less than 3 PRT, do nothing - Enunciate failure in HK	- If loss of more than 3 PRT, use default values ³ . - Enunciate failure in HK	- No effects



3	Bed pressure sensors P1 to P6	Run	Yes	Yes ¹	- Initiate 5 (or 4) bed operation if possible, if already in 4 bed mode, remove power on heaters and go to Ready mode - ENUNCIATE FAILURE IN HK	- SCS RUNNING IN DEGRADED MODE ² - TEMPERATURE INCREASE
---	-------------------------------	-----	-----	------------------	--	---

Table 7-7

Notes:

- 1- Recovery is only possible if two or less compressor sensors are in failure mode.
- 2- Degraded mode implies higher temperature, reduced cooling power and reduced temperature stability at the cold end.
- 3- Temperature default value must be available in LU table for PRT (270K) and for JT.

7.3.1.1.6. Other Sensors

ID#	Failure on:	Operating mode	Isolation	Recovery	SCE Software Actions	Effect on SCS
4	HPST Pressure sensor P7	Run	Yes	Yes	- Use value of the highest bed pressure sensor (P1 to P6)	- No effects
5	LPSB Pressure sensor P8	Run	Yes	No	- Enunciate failure in HK	- No effects
6	Pre cooler temperature sensors, T8 to T12	Run	Yes	No	- Enunciate failure in HK	- No effects
7	Cold End temperature sensors, LR1 & LR2, T1 to T4	Run	Yes	Yes ¹	- Use the value of the redundant sensor if possible, if not, do nothing - Enunciate failure in HK	- No effects
8	Cold End temperature sensors, JT, T7, T30	Run	Yes	Yes ¹	- Use the value of the redundant sensor if possible, if not, use default JT values ² . - Enunciate failure in HK	- No effects
9	Cold End temperature sensors, LR3, T5 & T6	Run	Yes	Yes ¹	- Use the value of the redundant sensor if possible, if not, disable PID - Enunciate failure in HK	- No LR3 heating and regulation
10	LPSB temperature sensors T17 & T18	Run/Start Up & Run/Defrost	Yes	Yes	- If loss of one sensor, use the other one if possible, if not, remove power on H8 - Enunciate failure in HK	- No effects
		RUN/NORMAL	YES	YES	- ENUNCIATE FAILURE IN HK	- NO EFFECTS

Table 7-8

- 1- Here, it is possible to make the difference between an out of range value due to a failure and an out of range value due to physics by comparison of the values of the 2 sensors.
- 2- Temperature default value must be available in LU table for PRT (270K) and for JT.



7.3.1.1.7. Heaters failures

The Heaters failures are triggered by the value of the corresponding current sensor or by reading of the drop voltage on the 28 V for the heater connected on this line (H1 to H6), which is compared every 2 second (reading cycle).



ID#	Failure	Operating mode	Symptom Trigger	Detection Method	Isolation	Recovery	SCE Software Actions ⁷	Effect on SCS
1	GG Heaters H21 to H26 always OFF or ON	Run	Current value not compliant	The current value is compared to what it should be for each GG heaters ¹⁰	Yes	Yes ¹	- Remove power on this Gas-Gap bed. - Initiate 5 (or 4) bed operation if possible, if already in 4 bed mode, remove power on all heaters and go to Ready mode - Enunciate failure in HK	- SCS running in degraded mode ² - Temperature increase
2	LPSB Start Up Heater H8 always ON	Run/Start Up & Run/Defrost	Over temperature in LPSB	LPSB temperature T17 & T18 > 350K	Yes	No	- Remove power on all heaters and go to Ready mode - Enunciate failure in HK	- SCS Stopped - Temperature increase
	LPSB Start Up Heater H8 always OFF	Run/Start Up & Run/Defrost	None	This failure cannot be detected	No	No	None	-SCS may not go to Normal mode or take long time to go to Normal mode
3	LPSB Sustain Heater H7 always ON or OFF	Run/Normal	Current value not compliant	The current value is compared to what it should be ¹⁰	No	No	- Use startup heater and cycle it at % of cycle time (minimum time step to be defined) to provide the proper power - Enunciate failure in HK	No effect on the cooler if time step in cycling period is below 1s.
4	Cold End Heaters LR3, H31 & H32 always ON or OFF	Run/Normal	Current value not compliant	The current value is compared to what it should be ¹⁰	Yes	Yes ³	- Switch to the redundant heater if possible, if not, do nothing - Enunciate failure in HK	- No effect if switch is possible, if not, SCS stopped.
5	JT, H35 & H34 Always ON	Run/Start Up & Run/Normal (Run/Defrost excluded)	Over temperature on JT	JT temperature T7 or T30> TBD limit	Yes	Yes ³	- Enunciate failure in HK - Ask CDMS for shutdown ⁸	- Switch to redundant cooler (with ground command)
	JT, H35 & H34 Always OFF	Run/Defrost only	JT temperature not increasing	Check if JT temperature T7 or T30 can rise of 25K in 2 minutes	Yes	Yes ³	- Switch to the redundant heater (JT) if possible, if not, do nothing - Enunciate failure in HK	- No effect if switch is possible, if not, SCS in Ready mode, loss of cooling and temperature increase
6	Filter, H33 & H36 Always OFF	Run/Defrost only	None	This failure cannot be detected as quick as possible ⁹	No	No	None	-Defrost process useless
	Filter, H33 & H36 Always ON	Run/Defrost only	None	THIS FAILURE CANNOT BE DETECTED AS QUICK AS POSSIBLE ⁹	No	No	NONE	-JT TEMPS WILL INCREASE OVER LIMIT

Table 7-9

Notes:

1-Recovery is only possible if two or less compressor heaters are in failure mode.

2- Degraded mode implies higher temperature, reduced cooling power and reduced temperature stability at the cold end.



3- Recovery is only possible once.

4- NA

5- For each bed, discrimination between H1n and Hn heater failure is not possible.

6- To be able to discriminate between JT and Filter heaters failures, the Filter heater is powered at the maximum 4 seconds after the JT heater (2 sensors reading cycles).

7- All these software actions, excepted for enunciating failure on HK, are performed when the considered heaters cannot be powered (failure on heater ON command). If a heater cannot be stopped, the action is to enunciate the problem in HK.

8 – Action asked to the CDMS (TM(5,1) ID10)

9- Can be detected in Ground

10- The current value is compared between what it should be by calculation and what it is measured in the TM. The comparison is made 3 times with 3 consecutives measure. Any action is started only if the 3 comparisons are identical

7.3.1.1.8. Actions on Electronics failures

The action triggered here are action from the SCE OBSW, basically to put the system in a safe mode, letting ground operator taking a major decision. Some of these actions, especially those triggered by critical parts failures, are including request for CDMS actions.

7.3.1.1.9. Critical parts failures

ID#	Failure on	Operating mode	Symptom Trigger	Isolation	Recovery	SCE Software Actions	Actions Requested to CDMS by SCE ¹	CDMS Actions ¹	Effect on SCS
1	Processor Failure	All mode	Watchdog first level time out, 63.9msec.	No	Yes	- Rearm watchdog for 112 µsec. - Enunciate failure in HK			- No effect
			Watchdog second level time out, 64msec.	No	Yes	- Reset Processor - Remove power on all heaters - Enunciate failure in HK	- Ask CDMS to shutdown the 20A power line.	- Shutdown of the 20A power line	- SCS Stopped, waiting for ground commands - Temperature increase



			CDMS Watchdog time out	Yes	Yes			- Shutdown both power lines by the CDMS ¹	- Switch to redundant cooler (with ground command)
2	FPGA Failure	All mode, Boot excepted	Time out on ADC reading AND bad FPGA state bit in register	No	No	- Enunciate failure in HK	- Ask CDMS for shutdown	- Shutdown of both power line	- Switch to redundant cooler (with ground command)
3	Memory Failure	Note 2	Read after writing default detected	No	No	- Enunciate failure in HK			- No effects
4	1553 failure	Boot	Internal check test fail on 1553 HW	Yes	No	- Stop any action and report in memory			- No immediate effects
		All mode	Wrong command detected	Yes	No	- Command rejected - Enunciate failure in HK			- No effects
5	Over temperature on electronics	Run	Parts temperature sensors over first limit level	No	No	- Enunciate failure in HK			- No effect
			Parts temperature sensors over second limit level	No	No	- Enunciate failure in HK	- Ask CDMS for shutdown	- Shutdown of both power line	- SWITCH TO REDUNDANT COOLER (WITH GROUND COMMAND)

Table 7-10

Notes:

1- See Table 7-14

2- Done by TC(8,4) in Boot only for the RAM and Boot & Init for PROM and EEPROM, or by TC(6,2) in all modes.



7.3.1.1.10. Power failures

ID#	Failure on:	Operating mode	Symptom Trigger	Isolation	Recovery	SCE Software Actions	Effect on SCS
1	12 Volt failure	Run	Voltage out of 10% range for less than 120 sec	Yes	Yes	- Enunciate failure in HK	- Short-term loss of pumping action.
			Voltage out of 10% range for more than 120 sec	Yes	No	- Remove power on Compressors heaters including Gas Gaps and go to Ready Mode. - Enunciate failure in HK	- SCS Stopped - Temperature increase
2	High Power 28 Volt primary power failure	Run	Voltage out of 10% range	Yes	No	- ENUNCIATE FAILURE IN HK	- LOSS OF PUMPING ACTION.

Table 7-11

7.3.1.1.11. Actions for safety

The action triggered here are only action from the SCE OBSW, basically to put the system in a safe mode, letting ground operator taking a major decision. No action from the CDMS is requested here.

ID#	Trigger	Operating mode	Isolation	Recovery	Software Actions	Effect on SCS
1	Bed pressure sensors P1 to P7 > 55 bars ²	Run	Yes	No	- Remove power on all heaters and go to Ready mode - Enunciate failure in HK	- SCS Stopped - Temperature increase
2	Bed Temperature ¹ T _{B1} to T _{B6} > 525K ²	Run	Yes	No	- Remove power on all heaters and go to Ready mode - Enunciate failure in HK	- SCS Stopped - Temperature increase
3	LPSB temperature T17 & T18 > 350K ²	Run	Yes	No	- Remove power on all heaters and go to Ready mode - ENUNCIATE FAILURE IN HK	- SCS STOPPED - TEMPERATURE INCREASE

Table 7-12

Notes:

- 1- These temperatures are calculated with the value of the Thermocouple (T20 to T25) plus the reference temperature. The reference temperature is calculated by doing an average with the six PRT (T26, T27, T28, T29, T15 & T16) values, excluding the highest and the lowest value.
- 2- These values must be in the LU table.



7.3.1.1.12. Operational actions

ID#	Trigger	Op Mode	Isolation	Recovery	Software Actions	Effect on SCS
1	T_H^1 or $T_D^1 > \text{MNCET}$ OR $P7 < \text{minNTP}$ OR $P7 > \text{maxNTP}$ OR $T_{JT}^2 > \text{MNJT}$ AND Sensors reading Flag = OFF	Run/Normal	Yes	Yes	- Go back to "Startup" mode - Enunciate action in HK	- SCS running in Start Up mode - Pressure will decrease and go to normal value in less than 1 hour with no cooling capacity loss but with fluctuation in cycle time.
2	$T_{JT} < \text{MJT}$ AND $P7 > \text{MTP}$ AND Flow calculated < Flow expected AND Sensors reading Flag = OFF	Run/Start Up	Yes	Yes	- Start Defrost Process - Enunciate action in HK	- Temperature of JT and filters increase for a maximum of 3 hours.
3	$T_{CD}^3 > \text{CD Temp Limit}$ OR $P_{CD}^3 > \text{CD Press Limit}$ AND $20\text{A}/28\text{V}$ line present ⁷ AND Sensors reading Flag = OFF	Run	Yes	Yes ⁶	- Initiate 5 (or 4) bed operation if possible, if already in 4 bed mode, go to Ready mode - Enunciate action in HK	- SCS running in degraded mode ⁵ - Temperature increase
4	$T_{HU}^4 < \text{HU Temp Limit}$ OR $P_{HU}^3 < \text{HU Press Limit}$ AND $\text{HPST Press} > \text{HU Press Limit}$ AND $20\text{A}/28\text{V}$ line present ⁷ AND Sensors reading Flag = OFF	Run	Yes	Yes ⁶	- Initiate 5 (or 4) bed operation if possible, if already in 4 bed mode, go to Ready mode - Enunciate action in HK	- SCS RUNNING IN DEGRADED MODE ⁵ - TEMPERATURE INCREASE

Table 7-13



Notes:

- 1- T_H = Temperature of Heating bed and T_D = Temperature of Desorbing bed. These temperatures are calculated with the value of the Thermocouple plus the reference temperature. The reference temperature is calculated by doing an average with the six PRT (T26, T27, T28, T29, T15 & T16) values, excluding the highest and the lowest value.
- 2- T_{JT} = Temperature of JT (T7 or T30)
- 3- T_{CD} = Temperature of the Cooling Down Bed, P_{CD} = Pressure of the Cooling Down Bed
- 4- T_{HU} = Temperature of the Heat Up Bed, P_{HU} = Pressure of the Heat Up Bed
- 5- Degraded mode imply, higher temperature, reduced cooling power and reduced temperature stability at the cold end
- 6- Recovery is only possible if two or less compressor sensors are in failure mode.
- 7- In that case, the 20A/28V line must be present and also in the previous state.

7.3.1.1.13. External FDIR

The action triggered here are actions requested from the CDMS software, triggered by Service 5 telemetry, on normal operation or failure mode.

ID#	OBSW Action	Internal Trigger	Status	Isolation	Recovery	External Trigger ¹	CDMS Software Actions Required ²	Effect on SCS
1	Enter in Ready mode from Init mode	- Ground command	Normal Operation	NA	NA	TM(5,1) ID3	- Switch ON the 20A power line	- SCS is ready to run in Start Up mode
2	Go back in Init mode from Ready mode	- Ground command	Normal Operation	NA	NA	TM(5,1) ID2	- Switch OFF the 20A power line	- SCS Stopped, waiting for ground commands.
3	Enter in Shutdown mode	- Ground command	Normal Operation	NA	NA	TM(5,1) ID9	- Switch OFF the 20A power line	- SCS Stopped.
4	Error Detection	Parts T sensors over second limit level (see Table 7-15)	Failure mode	No	No	TM(5,4) ID11	- Shutdown of both power line	- SCS Stopped.
5	NA	NA				CDMS WATCHDOG ON SCE TIME OUT	- SHUTDOWN OF BOTH POWER LINE	- SCS STOPPED.

Table 7-14

Notes:

- 1 see Table 7-15 below, extracted from the OBSW TC&TM Structure
- 2 The CDMS Actions should enabled or disabled.



7.3.1.1.14. Service 5 telemetry Event Report TM(5,1)

Event ID	Description	Report type	Satellite action
4	Boot mode entered	Event	Switch off 2nd power line (1)
2	Init mode entered	Event	Switch off 2nd (20A) power line (2)
3	Ready mode (Health monitor) entered	Event	Switch on 2nd (20A) power line (3)
4	Ready mode (Health Check) entered	Event	None
5	Ready mode (Regeneration) entered	Event	None
6	Run mode (startup) entered	Event	None
7	Run mode (defrost) entered	Event	None
8	Run mode (normal) entered	Event	None
9	Shutdown mode entered	Event	Switch off 2nd power line (20A)
10 (4)	Bed number change	Exception	None
11	Switch Off	Error	Switch off both (20A & 5A) power lines

Table 7-15

Notes:

- (1) **BOOT SW does not generate TM(5). In case of transition to BOOT Mode (or from BOOT to INIT) no event will be generated, so no CDMS action can be triggered. Anyway, when entering BOOT from INIT the SCE loses communication with the S/C: this triggers a DLL OBCP that includes a 2nd power line (20A) switch OFF.**
- (2) **This event (ID=2) is generated only when transitioning to INIT from other Modes than BOOT. BOOT to INIT transition does NOT generate TM(5,1,ID=2) event. The CDMS will be asked to switch OFF 2nd power line for each transition to INIT (except from BOOT)**
- (3) *The satellite will switch on 2nd power line (20A) in all case, even when transition from run to ready (where it is not necessary as the power line is already on).*
- (4) *This event is sent only if a bed was autonomously detected as bad. Then, the following cases will not be reported thanks to this event:*
- *Bed removal / insertion by command*
 - *Bed removal / insertion by transition startup → normal and normal → startup.*
 - *Bed Removal from other FDIR action (different of bad bed detection).*



8. Sorption Cooler System On-board Software

8.1. Introduction

The sorption cooler electronics include on-board software (OSW) that drives the sorption cooler, ensure its security and allows the communication with ground by means of telecommands and telemetries.

This chapter describes the Planck Sorption Cooler On-board Software. All OSW functions are included together with the algorithms needed to drive the SCS.

The task of the Planck Sorption Cooler On-board Software is to function as an interface between the CDMU of the satellite and the SCS.

The purpose of the Planck Sorption Cooler On-board Software is to:

- ▶ Drive the sorption cooler
- ▶ Detect abnormal situations and react if a problem is detected in order to ensure the sorption cooler and its environment health. This is done by reading temperature and pressure sensors values from the sorption cooler.
- ▶ Read temperature, voltage and intensity sensors from sorption cooler electronic.
- ▶ Receive commands from CDMU sent by users from ground
- ▶ Send housekeeping data to CDMU that will be transmitted to ground by telemetry.

In order to perform the above listed items the SCS On-board Software shall:

- ▶ Control heaters:
 - Time and control of 18 compressor activation relays within a sequence to maintain a constant cold-end temperature.
 - Warm-up of the J-T and the coldest filter by ground command only.
 - Control power during heating and desorption, and to accommodate degradation (end-of-life performance) of the cooler (i.e., compressor assemblies).
- ▶ Monitor compressor temperatures, pressures, power and electronic values:
 - Sense 25 SCC temperature sensors.
 - Sense 8 SCC pressure transducers.
 - Sense 5 SCE voltage sensors.
 - Sense 13 SCE intensity sensors.
 - Sense 3 SCE temperature sensors
- ▶ Perform diagnostics and appropriate responses to protect the sorption cooler from catastrophic failures.
- ▶ Provide closed-loop control of the LR3 temperature based on temperature and heater power feedback



- ▶ Communicate with the DPU thanks to the MIL-STD-1553B interface:
 - Read up-link parameters and write downlink parameters through communication with the S/C.
 - Process periodic ground uplink commands or a command table to modify control parameters (switch times, control values such as warning levels, and heater levels) to enable optimization of cooler performance in the actual flight environment and to accommodate aging of the cooler and the temperature surrounding environmental surfaces on-orbit.

8.2. Instruction

8.2.1. First launch: set the lookup table and applicative software

When software starts for the first time, several values shall be put in EEPROM memory in order to store:

- The position of the lookup table in EEPROM
- The lookup table
- The applicative software
- The checksums of each blocks stored in checksum base address (see 8.3.14).

This operation needs to be performed only once and not at every start up of the electronics.

IMPORTANT

For SCS-R unit has been reported an error in EEPROM#1. This EEPROM section should not be used for any SCS memory operations. However, since no OBSW or data is stored in such memory area this has no impact on functionality of SCS-R.

Position of the lookup table

It is stored in three fixed addresses of the lookup table: 0x8007ffa, 0x8007ffc and 0x8007ffe. The three addresses must have the same value (the lookup table base address).

- EEPROM address = 0x8007ffa → value 1
 - EEPROM address = 0x8007ffc → value 2
 - EEPROM address = 0x8007ffe → value 3
1. If the three values are identical : lookup table base address will be value1
 2. If only two values are identical (from example value2 and value3) : lookup table base address will be value2
 3. If the three values are different: lookup table base address will be a default address: 0x80000000

Example: set lookup table at position 0x80040100:

1. Select 'memory load telecommand': TC(6,2).
2. Select memory Id = 0x8007 - Select start address = 0xffff - Select size = 1
3. Select data (word 0) = 0x8004 - Select data (word 1) = 0x100
4. Launch TC(6,2)
5. Select memory Id = 0x8007 - Select start address = 0xffff - Select size = 1
6. Select data (word 0) = 0x8004 - Select data (word 1) = 0x100
7. Launch TC(6,2)
8. Select memory Id = 0x8007 - Select start address = 0xffff - Select size = 1



9. Select data (word 0) = 0x8004 - Select data (word 1) = 0x100
10. Launch TC(6,2)

Store the lookup table

The lookup table shall be stored in EEPROM at the address specified at 0x8007ffa, 0x8007ffc and 0x8007ffe.

Example: load the lookup table at address 0x80040100

1. Select 'memory load telecommand': TC(6,2).
2. Select memory Id = 0x8004 - Select start address = 0x100 - Select size = lookup table size
3. Set lookup table data: each parameter is 32-bits size. Data (word 0) = lookup table parameter 0 MSB – Data (word 1) = lookup table parameter 0 LSB – Data (word 2) = lookup table parameter 1 (MSB) – Data (word 3) = lookup table parameter 1 (LSB).....
4. Launch TC(6, 2)

Store the checksums

The both EEPROM checksums are stored in a EEPROM zone defined in lookup table: parameter: "[SW_CHECKSUM_1_ADR](#)" for EEPROM 1 and "[SW_CHECKSUM_N_ADR](#)" for EEPROM n. When storing the lookup table in EEPROM, the EEPROM checksum shall be written automatically.

To change EEPROM checksum zone, the two lookup table parameters can be updated: "[SW_CHECKSUM_1_ADR](#)" should be between: 0x80000000 and 0x8003ffff (example: 0x80030000) and "[SW_CHECKSUM_N_ADR](#)" should be between: 0x80040000 and 0x8007ffff (example: 0x80070000)

Store the applicative software

The applicative software is stored in EEPROM thanks to the 'memory load' telecommand. The applicative software base address is set in lookup table: "[SW_ASW_ADR](#)". This parameter should be between 0x80000000 and 0x8007ffff (example: 0x80050000). The applicative software must be stored at the same address as the address specified in lookup table.

New version of the applicative software is given, on-ground, within a text file. This text file is generated by "patchasw.exe" version 1.2 (31 august 2006) written and maintained at LPSC. "patchasw" converts stk file (generated by the compiler) to a text file, directly downloadable to the on-board software.

This text file contains a certain number of lines. Each line represents a 16-bits word of the applicative software. The ASW structure is described in 8.2.2

Example: provided text file:

0003	→	EEPROM word 0 MSB. In the example: must be the MSB part of EEPROM at address 0x80050000
0e3f	→	EEPROM word 0 LSB. In the example: must be the LSB part of EEPROM at address 0x80050000
0000	→	EEPROM word 1 MSB. In the example: must be the MSB part of EEPROM at address 0x80050001
0000	→	EEPROM word 1 LSB. In the example: must be the LSB part of EEPROM at address 0x80050001
0000	→	EEPROM word 2 MSB. In the example: must be the MSB part of EEPROM at address 0x80050002
0100	→	EEPROM word 2 LSB. In the example: must be the LSB part of EEPROM at address 0x80050002
0000	→	EEPROM word 3 MSB. In the example: must be the MSB part of EEPROM at address 0x80050003
0100	→	EEPROM word 3 LSB. In the example: must be the LSB part of EEPROM at address 0x80050003
0000	→	EEPROM word 4 MSB. In the example: must be the MSB part of EEPROM at address 0x80050004
.....	→	etc...



The file size is huge and is higher than TC(6,2) maximum data size. It must be cut in order to generate several sub-files which size fits with one telecommand. Each sub-file represents a part of the applicative software to load in EEPROM and must be sent via TC(6,2).

Example: storing the applicative software at address 0x80050000 with lookup table placed at address 0x80040100

1. Set lookup table parameter "**SW_ASW_ADR**" to 0x80050000:
 - a. Select 'memory load' telecommand: TC(6,2)
 - b. Select 'memory ID' = 0x8004 – Select 'start address' = 0x101. select size = 1.
 - c. Set lookup table data: word 0 = 0x8005 - word 1 = 0x0
 - d. Launch the telecommand.
2. Load first sub-file to EEPROM via TC(6,2): memory ID' = 0x8005 – 'start address' = 0x0. Size = sub-file number of lines / 2 (represents the number of 32-bits EEPROM words).
3. Load second sub-file to EEPROM via TC(6,2): memory ID' = 0x8005 – 'start address' = 0x0+number of 32-bits words previously written. Size = sub-file number of lines / 2.
4. Same process for all sub-files.

This procedure needs to be performed autonomously by the ground software as more than 1000 sub files are usually generated.

Notes

- Several lookup table can be stored in EEPROM at different positions. To select which lookup table to be used, the addresses 0x8007ffa, 0x8007ffc and 0x8007ffe must points to the required lookup table address.
- Several applicative software can be stored in EEPROM at different position. To select which applicative software to be used, the lookup table parameter "**SW_ASW_ADR**" must points to the required applicative software to use.
- **Beware of overlaps between lookup table, applicative software and checksums areas. Select address with sufficient space between the zone**
 1. EEPROM addresses 0x8007ffa, 0x8007ffc and 0x8007ffe shall not be overwritten
 2. Applicative software size is approximately 30 K words of 32 bits.
 3. Lookup table size is approximately 150 words of 32 bits
 4. Checksum zone size is 1024 words of 32 bits per zone (as two zones are defined: for EEPROM 1 and EEPROM n)

IMPORTANT

The maximum size of memory load commands allowed is 50 SAUs. Bigger size uploads lead to failure of SCS to accept command and eventual switch-off of SCS by OBCP from 1553 FDIR on TFh TC = SCS RT \"SICK TC\".

TC memory upload rate of 1 Hz (one TC per second) is ok.



8.2.2. Applicative Software Structure in EEPROM

The following table show the applicative software format stored in EEPROM. When patching the applicative software to EEPROM, TC(6, 2) must send a series of 16-bits words with the structure described in the table below.

The applicative software structure is composed of:

- Segments (containing useful data).
- Gaps between segments (filled with 0)

Word	EEPROM MSB (bits 16 to 31)	EEPROM LSB (bits 0 to 15)
0	Number of segments of the applicative software.	Checksum of the overall applicative software (including gaps between segments)
1	First segment base address MSB	First segment base address LSB
2	First segment size (number of 48bits words) MSB	First segment size (number of 48bits words) LSB
3	2d segment base address MSB	2d segment base address LSB
4	2d segment size (number of 48bits words) MSB	2d segment size (number of 48bits words) LSB
...
n	Last segment base address MSB	Last segment base address LSB
n+1	Last segment size (number of 48bits words) MSB	Last segment size (number of 48bits words) LSB
n+2	First segment data word 0 32..47	First segment data word 0 16..31
	First segment data word 0 0..15	First segment data word 1 32..47
	First segment data word 1 16..31	First segment data word 1 0..15
	...	First segment data word last 0..15
	2d segment data word 0 32..47	2d segment data word 0 16..31
	2d segment data word 0 0..15	2d segment data word 1 32..47
	2d segment data word 1 16..31	2d segment data word 1 0..15

	2d segment data word last 0..15	0x0000
	3d segment data word 0 32..47	...

	Last segment data word last 16..31	Last segment data word last 32..47
		Last segment data word last 0..15



8.2.3. Diagram of the memories

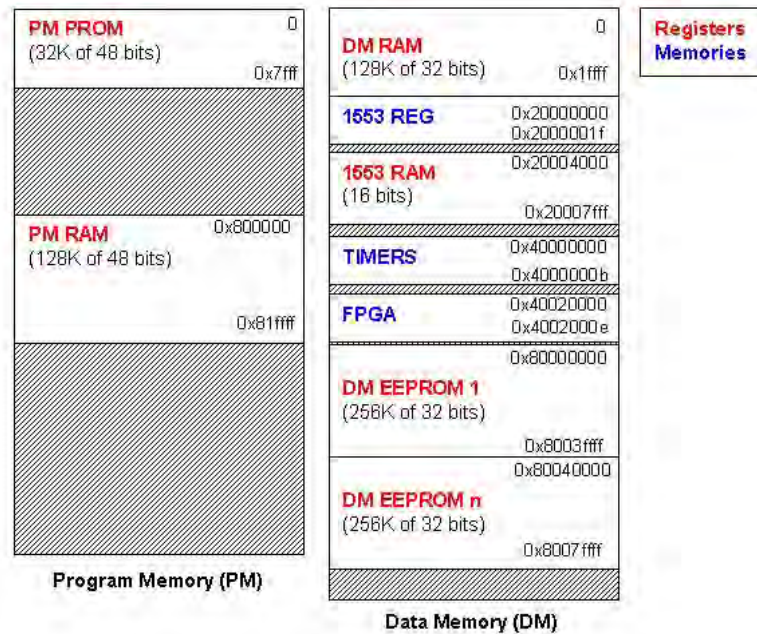

Figure 8-1

IMPORTANT

For SCS-R unit has been reported an error in EEPROM#1. This EEPROM section should not be used for any SCS memory operations. However, since no OBSW or data is stored in such memory area this has no impact on functionality of SCS-R.

The maximum size of memory load commands allowed is 50 SAUs. Bigger size uploads lead to failure of SCS to accept command and eventual switch-off of SCS by OBCP from 1553 FDIR on TFh TC = SCS RT \"SICK TC\".

TC memory upload rate of 1 Hz (one TC per second) is ok.



8.3. Reference

8.3.1. List of operations

The operations that can be launched from user are listed below:

Object	Operation	Software	Chapter
Common PSICD features	Telecommand Report	BOOT/ASW	8.3.2
	Housekeeping and Diagnostic Report	BOOT/ASW	8.3.3
	Event Report	BOOT/ASW	8.3.4
	Time Management	BOOT/ASW	8.3.5
	Report Enabled Telemetry	BOOT/ASW	8.3.6
	Link Report	BOOT/ASW	8.3.7
Memory Operation	Memory Load	BOOT/ASW	8.3.8
	Memory Dump	BOOT/ASW	8.3.9
	Memory Check	BOOT/ASW	8.3.10
Hardware Test	Test PM PROM (checksum)	BOOT/ASW	8.3.11
	Test PM RAM (read/write)	BOOT	8.3.12
	Test DM RAM (read/write)	BOOT	8.3.13
	Test DM EEPROM (checksum)	BOOT/ASW	8.3.14
	Test FPGA (*1)	BOOT	8.3.15
	Test 1553 (*1)	BOOT	8.3.16
	Test External Timers (*1)	ASW	8.3.17
	Test ADC (*1) (*2)	ASW	8.3.18
Applicative Software Transfer		BOOT	8.3.19
Stop Process		BOOT/ASW	8.3.20
Sorption Cooler Specific	Mode Change Telecommands	BOOT/ASW	8.3.21
	Operations available on all modes	BOOT/ASW	8.3.22
	Boot Mode Description	BOOT	8.3.23
	Init Mode Description	ASW	8.3.24
	Ready Mode Description	ASW	8.3.25
	Run Mode Description	ASW	8.3.26
	Shutdown Mode Description	ASW	8.3.27
	Set Initial Bed Position	ASW	8.3.28
	Return to Initial Bed State	ASW	8.3.29
	Set Bed State	ASW	8.3.30
Set Device State	ASW	8.3.31	
Sensors acquisition		ASW	8.3.32
EEPROM configuration		BOOT/ASW	8.3.33
FDIR (Failure Detection and Recovery)	Reading chains Failure	ASW	8.3.35.1
	Sensors Failures	ASW	8.3.35.2
	Heaters Failures	ASW	8.3.35.3
	Critical Parts Failures	ASW	8.3.35.4
	Power Failures	ASW	8.3.35.5
	Actions for safety	ASW	8.3.35.6
	Operational actions	ASW	8.3.35.7

Table 8-1. List of Operations

(*1): these hardware tests can not be launched by telecommand. They are launched automatically only if bit 'Boot autonomous hardware tests' or 'Applicative autonomous hardware tests' is set.

(*2): ADC test may be performed when applicative software starts and is also performed automatically during execution.



8.3.2. Telecommand Report

Functional Description

Reports a telemetry packet after reception of a telecommand. The list of telecommand responses are specified in Chapter 10 (TC responses).

Telemetry : Type / SubType	Name
TM(1,1)	Telecommand Acceptance Report : Success
TM(1,2)	Telecommand Acceptance Report : Failure
TM(1,3)	Telecommand Execution Report : Started
TM(1,7)	Telecommand Execution Report : Completed
TM(1,8)	Telecommand Execution Report : Failure

Table 8-2. Telecommand Report

Cautions and Warnings

TM(1,1), TM(1,2) and TM(1,3) are sent as soon as telecommand has been received. TM(1,7) and TM(1, 8) are sent as soon as the requested process is over (it may last several seconds)

8.3.3. Housekeeping and Diagnostic Report

Functional Description

Reports a housekeeping / diagnostic telemetry packet periodically or after a special process. The list and content of housekeepings and diagnostics packets are described Chapter 10 (Housekeeping Parameter Report and Diagnostic Parameter Report).

Telemetry : Type / Sub Type	SID	Name
TM(3, 25)	1	Boot Software Housekeeping
TM(3, 25)	2	Applicative Software Non Essential Packet Housekeeping
TM(3, 25)	3	Applicative Software Essential Packet Housekeeping
TM(3, 26)	1	Boot diagnostic
TM(3, 26)	2	Applicative diagnostic
TM(3, 26)	3	Health Check
TM(3, 26)	4	Regeneration

Table 8-3. Housekeeping and Diagnostic Report

BSW Housekeeping – ASW Housekeeping (Essential and Non Essential)

Boot Software and Applicative Software Non Essential Housekeeping Packets reports software status (current mode, error status...), sensors and heaters values. They are sent once a second during execution of the boot or applicative software. Applicative Software Essential Housekeeping Packet is sent 10 seconds during execution of the applicative software. These packets reports:



Name	Field	Explanation
Operating Status	Current mode	BSW: boot ASW: init, health monitor... shutdown
	5 beds and 4 beds	BSW: Off for both in boot mode. ASW: only one bit is set to TRUE indicating if 1 or 2 beds were removed from cycle
	Current Process	≠0 if a process is currently running. 0 if no process is running. -Transfer applicative software process is set during applicative software transfer from EEPROM → RAM. BSW ONLY - Test Hardware process is set during one hardware test (launched by command) - Memory access process is set during a memory load, memory check or memory dump operation launched from commands TC(6, 2), TC(6, 5) or TC(6, 9).
	Applicative software transfer	BSW ONLY: Cleared when applicative software was fully transferred from EEPROM → RAM. It does not indicate that the transfer was right or wrong (this information is given in "Boot Diagnostic")
Fault Status OBSW	DAC Error	ASW ONLY: Digital Analog Converter (heaters) error. This error is set when can not apply value to variable heater (DAC)
	ADC nominal Busy	ASW ONLY: Nominal Analog Digital Converter (sensors) error: it stays busy too long.
	ADC nominal Out Of Range	ASW ONLY: Nominal Analog Digital Converter error: out of range. Range is defined from lookup table parameters : <FAULT_ELECTRONIC_ADC_REF-FAULT_ELECTRONIC_ADC_DELTA; FAULT_ELECTRONIC_ADC_REF + FAULT_ELECTRONIC_ADC_DELTA>
	ADC redundant Busy	ASW ONLY: Redundant Analog Digital Converter (sensors) error: it stays busy too long.
	ADC redundant Out Of Range	ASW ONLY: Redundant Analog Digital Converter error: out of range.
	12 Volts Error	ASW ONLY:12 volts error. This error is set when 12 volts is outside the range defined in lookup table : < FAULT_ELECTRONIC_12V_LOW_LIMIT; FAULT_ELECTRONIC_12V_UP_LIMIT>
	28 Volts Error	ASW ONLY: 28 volts error. This error is set when 28 volts is outside the range defined in lookup table: < FAULT_ELECTRONIC_28V_LOW_LIMIT; FAULT_ELECTRONIC_28V_UP_LIMIT>
	Eeprom Write Error	EEPROM write error. This error is set after an eeprom write error or bad write/read comparison (read data ≠ written data)
	1553 Failure	1553 error. This error is set after bad 1553 initialization, bad access to telemetries FIFO or bad access to Transfer Layer.
	Watchdog 1 st level	ASW ONLY: Watchdog first limit reached (see AD8 and 8.3.35.4)
	Watchdog 2d level	ASW ONLY: Watchdog second limit reached (see AD8 and 8.3.35.4)
	Electronics Temperature Over limit 1	ASW ONLY: Electronics temperature reached first limit (see AD8). This error is set when electronics temperature is higher than a limit defined in lookup



		table: FAULT_ELECTRONIC_TEMP_FIRST. In that case, we use the sensor (on electronics) that outputs the highest temperature.
	Electronics Over Temperature limit 2	ASW ONLY: Electronics temperature reached second limit (see AD8). This error is set when electronics temperature is higher than a limit defined in lookup table: FAULT_ELECTRONIC_TEMP_SECOND. In that case, we use the sensor (on electronics) that outputs the highest temperature.
	Lookup Table Load Error	Lookup table load error (memory error) : this error is set when lookup table area in eeprom can not be read (from example address outside Eeprom area).
	Lookup Table Bad Content	Lookup table content is wrong (parameter(s) wrong defined). This error is set when one or several lookup table values are wrong (outside predefined ranges). See 8.3.34
	Lookup Table Bad Address	This error is set when lookup table base address (defined at 0x8007ffa, 0x8007ffc, 0x8007ffe) is not set correctly (at least two values must be identical for the triple-voting).
Fault Status SCE (ASW ONLY)	Normal Fault	Fault Detected in normal mode that leads to return to startup (See AD8). This error is set if triggers defined in Appendix 1 (transition normal → startup) are set.
	Bed Over Temperature	Bed Over temperature detected (See AD8). This error is set depending on trigger defined in 8.3.35.6.
	Bed Over Pressure	Bed Over pressure detected (See AD8). This error is set depending on trigger defined in 8.3.35.6.
	LPSB Over Temperature	LPSB Over temperature detected (See AD8) This error is set depending on trigger defined in 8.3.35.6.
	FPGA Error	FPGA error detected (see AD8). 'ADC busy' can come from an busy on ADC or an FPGA error. Electronics conditions (bits on registers) allow distinguishing the both cases.
	Internal Error	Software Error Detected. This error is set if one or more software errors found since last telemetry. This error is cleared on the next telemetries if the error disappeared. Error can be set if requested bed number is wrong within several software procedure (healthcheck , regeneration, sensor failure check).
Device status (ASW ONLY)	ADC0 – ADC1	Analog Digital Converter Nominal / Redundant Status
	H1 to H6 – H21 to H26 – H8 – H33 to H36 - H11 to H16 – H7 – H31 – H32	Heater status
	T1 to T18 – T20 to T30	Temperature sensors status
	P1 to P8	Pressure sensors status
Bed Status MSB (ASW ONLY)	Bed 0 to Bed 4	Bed 0 to 4 State (Heatup, Desorb, Cool, Absorb1, Absorb2, Absorb3, Off)
Bed Status LSB (ASW ONLY)	Bed 5	Bed 5 State (Heatup, Desorb, Cool, Absorb1, Absorb2, Absorb3, Off)
	Bed 0 to Bed 5 Norm	Bed 0 to 5 'normal only' state. See 8.3.26.
Fixed Heaters Activity (ASW ONLY)	H1..H6 – H21..H26 – H8 – H33.. H36	Current status (ON or OFF) of all fixed heaters. This status comes from a read on hardware register (not from sensors acquisition).
Variable Heaters	H11..H16 – H7 – H31 –	Current values of variable heaters (outputs from



Values (ASW ONLY)	H32	DAC). This status corresponds to the values applied to the DAC (calculated by the software, not from sensors acquisition).
Sensor Value T1 to T30 (ASW ONLY)	T1..T18 – T20..T30	Current values of temperature sensors (outputs from ADC). These values are the temperature sensors outputs.
Sensor Value P1 to P8 (ASW ONLY)	P1..P8	Current values of pressure sensors (outputs from ADC). These values are the pressure sensors outputs.
Voltage Value (ASW ONLY)	28V, 12V, 5V, +15V, -15V, 31V	Current values of voltage sensors (outputs from ADC). These values are the voltage sensors outputs.
Intensity Value (ASW ONLY)	H7 - H21..H26 – H31 – H32	Current values of intensity sensors (outputs from ADC). These values are the intensity sensors outputs.
Electronics T Values (ASW ONLY)	Cold Face – Warmest Face of PCB – Warm Face	Current values of electronics sensors (outputs from ADC). These values are the electronics temperature sensors outputs.
Reference Sensors (ASW ONLY)	Vgain – Voff – Calibration 1 – Calibration 2	Current values of calibration sensors (outputs from ADC). These values are the test sensors outputs. These values should be fixed.

Table 8-4. Housekeeping Packet Content

Note: in init mode, the sensors values reported to telemetry TM(3,25) do not represents all values as sorption cooler pressure and temperature sensors are not read.

Boot software Diagnostic – Applicative software Diagnostic

Boot and Applicative Software Diagnostics reports hardware tests status and applicative software transfer status.

Boot Software Diagnostic is sent after:

- hardware tests (launched autonomously at start of boot software, or launched by telecommand)
- Applicative software transfer EEPROM → RAM (launched autonomously at start of boot software, or launched by telecommand)

Applicative Software Diagnostic is sent after:

- hardware tests (launched autonomously at start of boot software, or launched by telecommand)

Name	Field	Explanation
Diagnostic 1553 (BOOT ONLY)	Described in AD07	1553 test launched autonomously at boot startup result. #0 means error detected. Not significant if hardware autonomous tests in not set.
Diagnostic FPGA	Described in AD07	FPGA test launched autonomously at boot startup result. #0 means error detected. Not significant if hardware autonomous tests in not set.
Diagnostic PM PROM	Described in AD07	PM Prom test result. #0 means error detected.
Diagnostic PM RAM (BOOT ONLY)	Diagnostic PM RAM Word 0 to Word 127	1 Word = 16 bits. Each bit represents one block. 1 block = 64 words of 48-bits PM RAM memory. Overall PM RAM = 128 Words * 16 bits * 64 words of 48 bits. #0 means error detected: if bit i of Word j is set to 1 → PM RAM block 16*j+i is bad.
	PM RAM Bad Address #0 MSB PM RAM Bad Address #0 LSB..... #15	The 16 first bad addresses are reported : MSB is bits 16..31 of bad address, LSB is bits 0..15 of bad address
Diagnostic DM RAM (BOOT ONLY)	Described in AD07	DM RAM test result. #0 means error detected. This procedure is written in assembly because C code



Diagnostic EEPROM	DM	Diagnostic DM EEPROM Word 0 to Word 127	requires DM ram for stack. 1 Word = 16 bits. Each bit represents one block. 1 block = 256 words of 32-bits DM EEPROM memory. Overall DM EEPROM = 128 Words * 16 bits * 256 words of 32 bits. ≠0 means error detected: if bit i of Word j is set to 1 → DM EEPROM block 16*j+i is bad.
Transfer ASW Result (BOOT ONLY)		Described in AD07	Applicative Software EEPROM → RAM transfer result. ≠0 means error detected.
Diagnostic Timers (ASW ONLY)	External	Described in AD07	9 External Timers + FPGA Timer test result. ≠0 means error detected.

Table 8-5. Boot And Applicative Diagnostic

Health Check Diagnostic

Health Check Diagnostic reports health check procedure current state and status.
 Health Check diagnostic is sent periodically once a second during health check mode.

Name	Field	Explanation
Current Health Check Test Number	Described in AD07	Health Check Test number that is currently being proceeded
Health Check Test Status LSB	Described in AD07	Status of Health Check Test 1 to 16 (only tests before 'Current Health Check Test Number' are significant during Health Check procedure. ≠0 means one (ore more) Health Check Test failed.
Health Check Test Status MSB	Described in AD07	Status of Health Check Test 17 to 29 (only tests before 'Current Health Check Test Number' are significant during Health Check procedure. ≠0 means one (ore more) Health Check Test failed.

Table 8-6. Health Check Diagnostic

Regeneration Diagnostic

Regeneration Diagnostic reports regeneration procedure current state and status.
 Regeneration Diagnostic is sent periodically once a second during regeneration mode.

Name	Field	Explanation
Current Regeneration Step	Described in AD07	Regeneration process number that is currently being proceeded
Regeneration process Status LSB	Described in AD07	Status of Regeneration Process 1 to 16 (only processes before 'Current Regeneration Step' are significant during Regeneration procedure. ≠0 means one (ore more) Regeneratin processes failed.
Regeneration process Status MSB	Described in AD07	Status of Regeneration Process 17 to 31 (only processes before 'Current Regeneration Step' are significant during Regeneration procedure. ≠0 means one (ore more) Regeneratin processes failed.

Table 8-7. Regeneration Diagnostic



8.3.4. Event Report

Functional Description

Following a specified event, an “event report packet” TM(5, 1), “exception report packet” TM(5, 2) or “error report packet” TM(5, 4) is sent.

An event/exception/error report packet is sent after the following event:

TM : Type / Sub Type	Event ID	Description	Report type	Satellite action
Event TM(5, 1)	4	Boot mode entered	Event	Switch off 2nd power line (1)
Event TM(5, 1)	2	Init mode entered	Event	Switch off 2nd (20A) power line (2)
Event TM(5, 1)	3	Ready mode (Health monitor) entered	Event	Switch on 2nd (20A) power line (3)
Event TM(5, 1)	4	Ready mode (Health Check) entered	Event	None
Event TM(5, 1)	5	Ready mode (Regeneration) entered	Event	None
Event TM(5, 1)	6	Run mode (startup) entered	Event	None
Event TM(5, 1)	7	Run mode (defrost) entered	Event	None
Event TM(5, 1)	8	Run mode (normal) entered	Event	None
Event TM(5, 1)	9	Shutdown mode entered	Event	Switch off 2nd power line (20A)
Exception TM(5, 2)	10 (4)	Bed number change	Exception	None
Error TM(5,4)	11	Switch Off	Error	Switch off both (20A & 5A) power lines

Table 8-8

Notes:

- (1) **BOOT SW does not generate TM(5). In case of transition to BOOT Mode (or from BOOT to INIT) no event will be generated, so no CDMS action can be triggered. Anyway, when entering BOOT from INIT the SCE loses communication with the S/C: this triggers a DLL OBCP that includes a 2nd power line (20A) switch OFF.**
- (2) **This event (ID=2) is generated only when transitioning to INIT from other Modes than BOOT. BOOT to INIT transition does NOT generate TM(5,1,ID=2) event. The CDMS will be asked to switch OFF 2nd power line for each transition to INIT (except from BOOT)**
- (3) *The satellite will switch on 2nd power line (20A) in all case, even when transition from run to ready (where it is not necessary as the power line is already on).*
- (4) *This event is sent only if a bed was autonomously detected as bad. Then, the following cases will not be reported thanks to this event:*
 - *Bed removal / insertion by command*
 - *Bed removal / insertion by transition startup → normal and normal → startup.*
 - *Bed Removal from other FDIR action (different of bad bed detection).*



~~**Boot mode entered event (Boot only)**~~

~~Is sent as soon as boot mode is entered. From example, after the transition boot → boot or init → boot~~

Init mode entered event (ASW only)

Is sent as soon as init mode is entered except from BOOT. For example, after the transition READY → init or init → init...

Health Monitor mode entered event (ASW only)

Is sent as soon as health monitor mode is entered. From example, after the transition init → health monitor, startup → health monitor...

Health Check mode entered event (ASW only)

Is sent as soon as health check mode is entered. From example, after the transition health monitor → health check.

Regeneration mode entered event (ASW only)

Is sent as soon as regeneration mode is entered. From example, after the health monitor → regeneration.

Startup mode entered event (ASW only)

Is sent as soon as startup mode is entered. From example, after the transition health check → startup, normal → startup, defrost → startup.

Defrost mode entered event (ASW only)

Is sent as soon as defrost mode is entered. From example, after the transition startup → defrost.

Normal mode entered event (ASW only)

Is sent as soon as normal mode is entered. From example, after the transition startup → normal.

Shutdown mode entered event (ASW only)

Is sent as soon as shutdown mode is entered. From example, after the transition startup → shutdown, normal → shutdown, defrost → shutdown...

Bed number change event (ASW only)

Is sent as soon as bed was declared bad and removed from cycle from autonomous bad bed detection procedure (see Chapter 7 “Bad Bed Detection Procedure”). If a bed was declared y from other mean (by telecommand, bad sensor etc...) this event will not be sent.

Switch Off (ASW only)

Is sent if:

- JT heater was autonomously detected bad (see Chapter 7).
- Both Analog Digital Converters ADC0 and ADC1 are bad (autonomous detection or set bad by command).
- Electronics temperature is over second (higher) limit (see Chapter 7 “Actions on Electronics Failures” id#4).

Switch off operation is performed by the satellite after reception of a TM(5, 4). It consists of cutting both power lines (12 volts and 28 volts). If switch off is send, the software will transition automatically to shutdown mode.

8.3.5. Time Management

Functional Description

The sorption cooler electronics includes a local on-board time (LOBT) that allows reporting a date with all telemetries. Two features are available.



Feature name	Procedure
Time synchronization	TC(9, 4) followed by TC(9, 5)
Time Verification Report	Ask with TC(9, 7). Result on TM(9, 9)

Table 8-9. Time Management feature list

Time synchronization

Time synchronization is used to resynchronize LOBT. Firstly, a TC(9, 4) must be sent to enable time synchronization followed by a TC(9, 5) that contains 48-bits time information. The LOBT will be resynchronized on the next board data bus synchronization signal following reception of TC(9, 5). See Chapter 10 “Service Type 9 : Time Management”.

Time verification report

Time verification report is used to report LOBT. A TC(9, 7) must be sent to ask the report and a TM(9, 9) will be received containing 48-bits LOBT information. This time corresponds to next 1553 bus synchronization signal just after reception of the telecommand. See Chapter 10 @ “Service Type 9 : Time Management”

Cautions and Warnings

A TC(9, 5) without TC(9, 4) previously sent have no effect.

8.3.6. Report Enabled Telemetry

All telemetries defined on sorption cooler electronics software can be enabled or disabled by telecommands. It is also possible to ask which telemetries are enabled.

Feature name	Procedure
Enable Generation of telemetry packet	TC(14, 1) including list of telemetry packets to enable
Disable generation of telemetry packet	TC(14, 2) including list of telemetry packets to disable
Request list of enabled telemetry packets	TC(14, 3) followed by the reception of a TM(14, 4) containing list of enabled telemetry packets

Table 8-10. Packet Transmission Control feature list

Enable Generation of telemetry packet

One or more telemetry packets can be enabled by reception of this telecommand. For TM(3, x) and TM(5, x) it is possible to select which packed ID needs to be enabled. See Chapter 10 and AD07“TC(14,1): Enable Generation of telemetry Packets”.

Disable Generation of telemetry packet

One or more telemetry packets can be disabled by reception of this telecommand. For TM(3, x) and TM(5, x) it is possible to select which packed ID needs to be disabled. See Chapter 10 and AD07“TC(14,2): Disable Generation of telemetry Packets”.

Request list of enabled telemetry packets

The TC(14, 3) telecommand (without arguments) is used to request the report of the enabled telemetry packets list. The TM(14, 4) that contains this list will then be received. See Chapter 10 and AD07“TC(14,3): Report Enabled Telemetry Packets” and “TM(14,4): Report Enabled Telemetry Packets”.

Cautions and Warnings

When launching the boot or applicative software, all telemetries are enabled. When transition from boot software → applicative software or applicative software → boot software, all telemetries will be re-enabled.



If a wrong telemetry definition {type, subtype, packet id} is declared inside TC(14, 1) or TC(14, 2) (example: wrong type and/or subtype and/or packet id), the telecommand will continue its execution enabling/disabling other telemetries but an error will be raised with TM(1, 2).

8.3.7. Link Report

TC/TM : Type / SubType	Name
TC(17, 1)	Perform Connection Test
TM(17, 2)	Link Connection Report

Table 8-11. Link Report

Link report is used to perform a simple connection test. A TC(17, 1) shall be send and the TM(17, 2) shall be received in response.

8.3.8. Memory Operation: Memory Load

IMPORTANT info for Memory Operations

For SCS-R unit has been reported an error in EEPROM#1. This EEPROM section should not be used for any SCS memory operations. However, since no OBSW or data is stored in such memory area this has no impact on functionality of SCS-R.

The maximum size of memory load commands allowed is 50 SAUs. Bigger size uploads lead to failure of SCS to accept command and eventual switch-off of SCS by OBCP from 1553 FDIR on TFh TC = SCS RT "SICK TC".

TC memory upload rate of 1 Hz (one TC per second) is ok.

Functional Description

Memory load telecommand TC(6, 2) allows loading data from ground to on-board memories. The telecommand includes:

TC(6,2)	Memory ID	defines the 16 higher bits (MSB) of the start address of the destination memory.
	Start Address	defines the 16 lower bits (LSB) of the start address of the destination memory.
	Length	defines the number of words of 32 bits for DM memories or 48 bits for PM memories to be loaded in destination memory.
	Data	contains the data to be loaded. If destination on-board memory is 48 bits, data must be defined in the following order in the telecommand: <ol style="list-style-type: none"> 1. Telecommand "data field" word 'n' → bits 32 to 47 2. Telecommand "data field" word 'n+1' → bits 16 to 31 3. Telecommand "data field" word 'n+2' → bits 0 to 15 If destination on-board memory is 32 bits, data must be defined in the following order in the telecommand: <ol style="list-style-type: none"> 1. Telecommand "data field" word 'n' → bits 16 to 31 2. Telecommand "data field" word 'n+1' → bits 0 to 15
	Checksum	define the checksum of the data to be loaded. This is needed by the on-board software to check that data was successfully loaded.

Table 8-12. Memory load telecommand arguments

All destinations memory areas are defined in AD07 @ "TC(6,2): Load Memory Using Absolute Address".



Note: when a memory load operation is performed on one Eeprom (including patch lookup table, patch applicative software), its checksum will be updated automatically.

8.3.9. Memory Operation: Memory Dump

Functional Description

Memory dump telecommand TC(6,5) allows dumping data from on-board memories to ground. The telecommand includes:

TC(6,5)	Memory ID	defines the 16 higher bits (MSB) of the start address of the source memory.
	Start Address	defines the 16 lower bits (LSB) of the start address of the source memory.
	Length	defines the number of words of 32 bits for DM memories or 48 bits for PM memories to be dumped from source memory.

Table 8-13. Memory dump telecommand arguments

All sources memory areas are defined in Chapter 10 and *AD07 "TC(6,2): Load Memory Using Absolute Address"*.

In response, the on-board software will send one or more TM(6, 6) "Memory Dump Absolute Address". The telemetry includes:

TM(6,6)	Memory ID	16 higher bits (MSB) of the dumped memory start address.
	Start Address	16 lower bits (LSB) of the dumped memory start address.
	Length	number of words (32 bits for DM memories or 48 bits for PM memories) dumped.
	Data	Data dumped from on-board memory. If on-board memory is 48 bits, data will appear in the following order: <ol style="list-style-type: none"> 1. Telemetry "data field" word 'n' → bits 32 to 47 2. Telemetry "data field" word 'n+1' → bits 16 to 31 3. Telemetry "data field" word 'n+2' → bits 0 to 15 If on-board memory is 32 bits, data will appear in the following order: <ol style="list-style-type: none"> 1. Telemetry "data field" word 'n' → bits 16 to 31 2. Telemetry "data field" word 'n+1' → bits 0 to 15 3. Checksum: checksum of the dumped data.
	Checksum	Contains the checksum of the dumped data

Table 8-14. Memory dump telemetry arguments

If the requested dump length ("Length" field of TC(6,5)) is up than the maximum telemetry size, more than one telemetry TM(6,6) will be sent.

8.3.10. Memory Operation: Memory Check

Functional Description

Memory check telecommand TC(6,9) allows checking on-board memories data. In response to the "memory check" telecommand, a telemetry TM(6, 10) will be sent reporting the checksum of the selected memory area. All sources memory areas are defined in Chapter 10 and *AD07 "TC(6,2): Load Memory Using Absolute Address"*.

Telecommand arguments are the same as TC(6,5) "memory dump": see Table 8-13

Telemetry TM(6,10) arguments are the same as TM(6,6) without "data" field : see Table 8-14.



8.3.11. Hardware Test: test PM PROM

Functional Description

Test PM PROM tests the PROM memory where is stored the boot software. This test can be launched:

- by telecommand TC(8, 4) "Test PM Prom"
- autonomously at boot startup: the lookup table parameter "LU=SW_AUTO_FUNCTIONS" "Boot autonomous hardware tests" shall be set. See Appendix 1 "Lookup Table".

At the completion of the test, a diagnostic packet TM(3,26) "Boot Software Diagnostic" (boot mode) or "Applicative Software Diagnostic" (init mode) is sent. Test result can be seen on the "Diagnostic PM Prom" field.

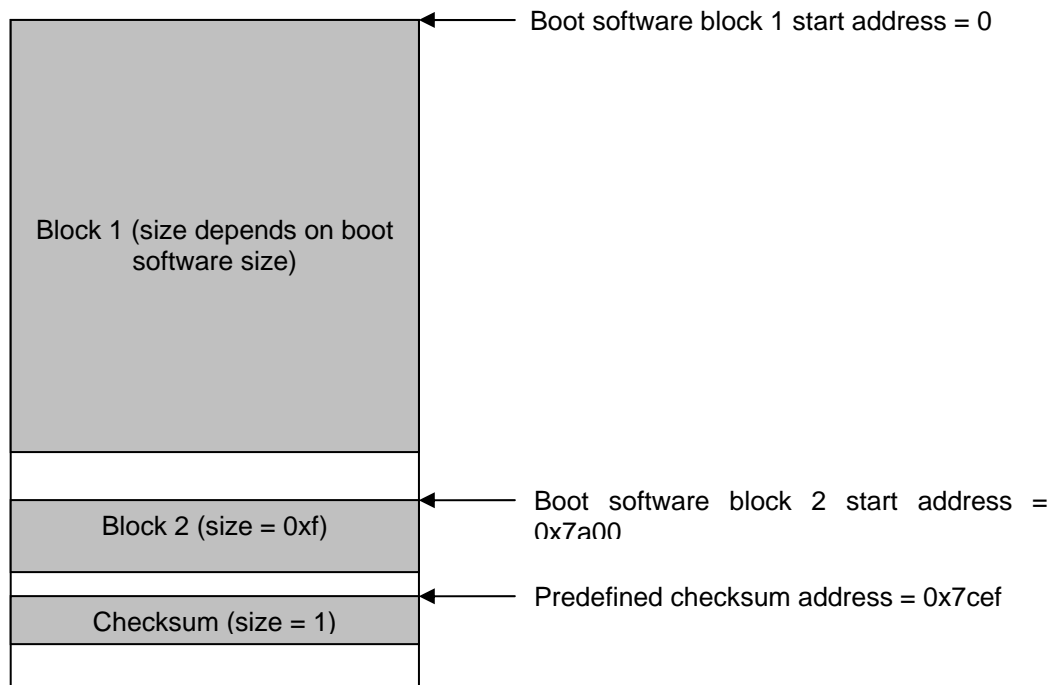

Figure 8-2: Test PM Prom

The "Test PM Prom" procedure will check the Prom segments where are stored the boot software:

- Block 1 represents the entire seg_rth segment and the usefull part of seg pmco. Block 1 starts at address 0 and size is 0x57a7
- Block 2 represents the useful part of seg_init segment. Block2 starts at address 0x7a00 and size is 0xf.
- The checksum word stored at address 0x7cef represents the both blocks checksum.

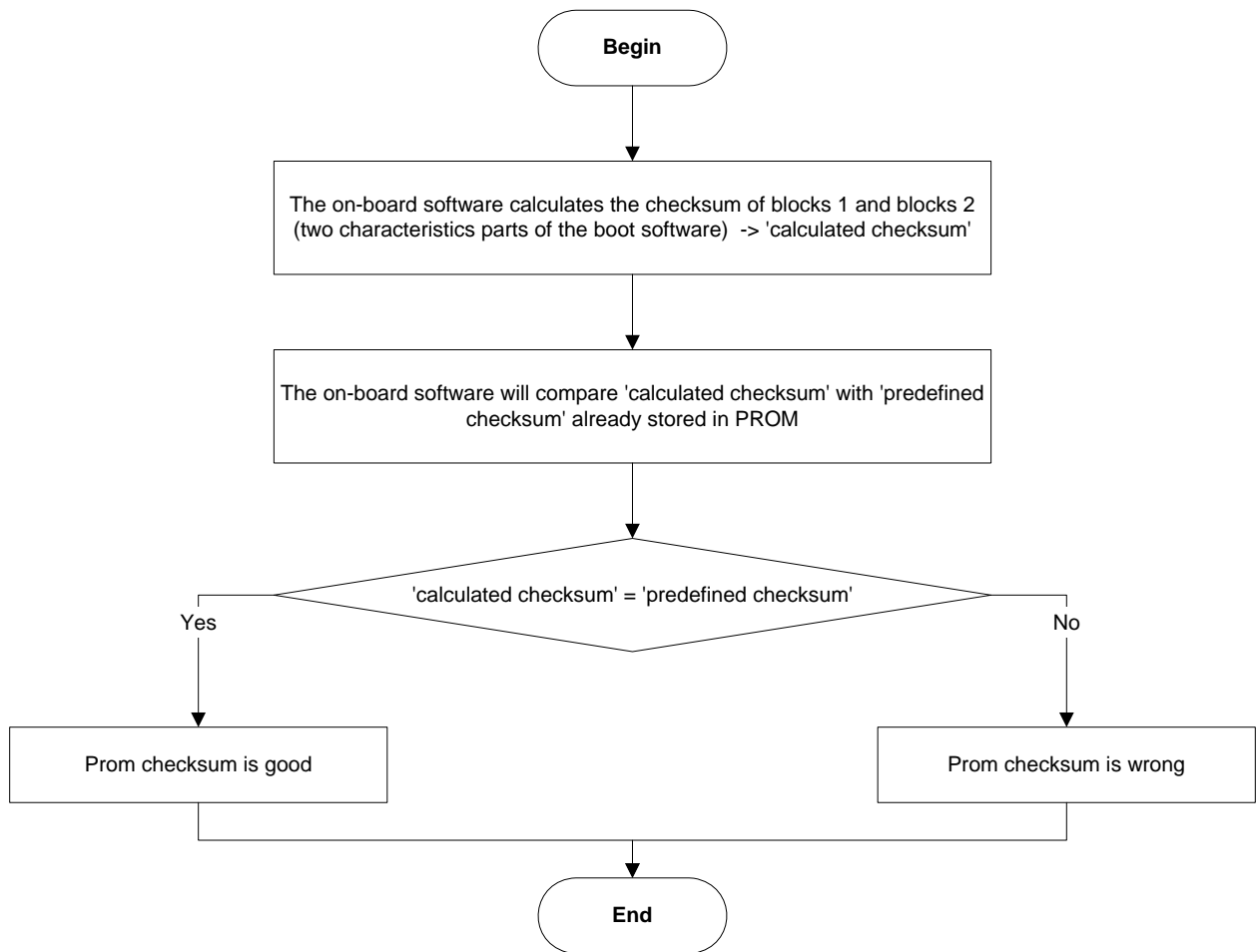

Figure 8-3: Test PM Prom algorithm



8.3.12. Hardware Test: test PM RAM (BSW ONLY)

Test PM RAM tests the RAM PM memory. This test can be launched:

- by telecommand TC(8, 4) "Test PM RAM"
- autonomously at boot startup: the lookup table parameter "LU=SW_AUTO_FUNCTIONS" "Boot autonomous hardware tests" shall be set. See Appendix 1 "Lookup Table".

At the completion of the test, a diagnostic packet TM(3,26) "Boot Software Diagnostic" is sent. Test result can be seen on the "Diagnostic PM Ram" fields.

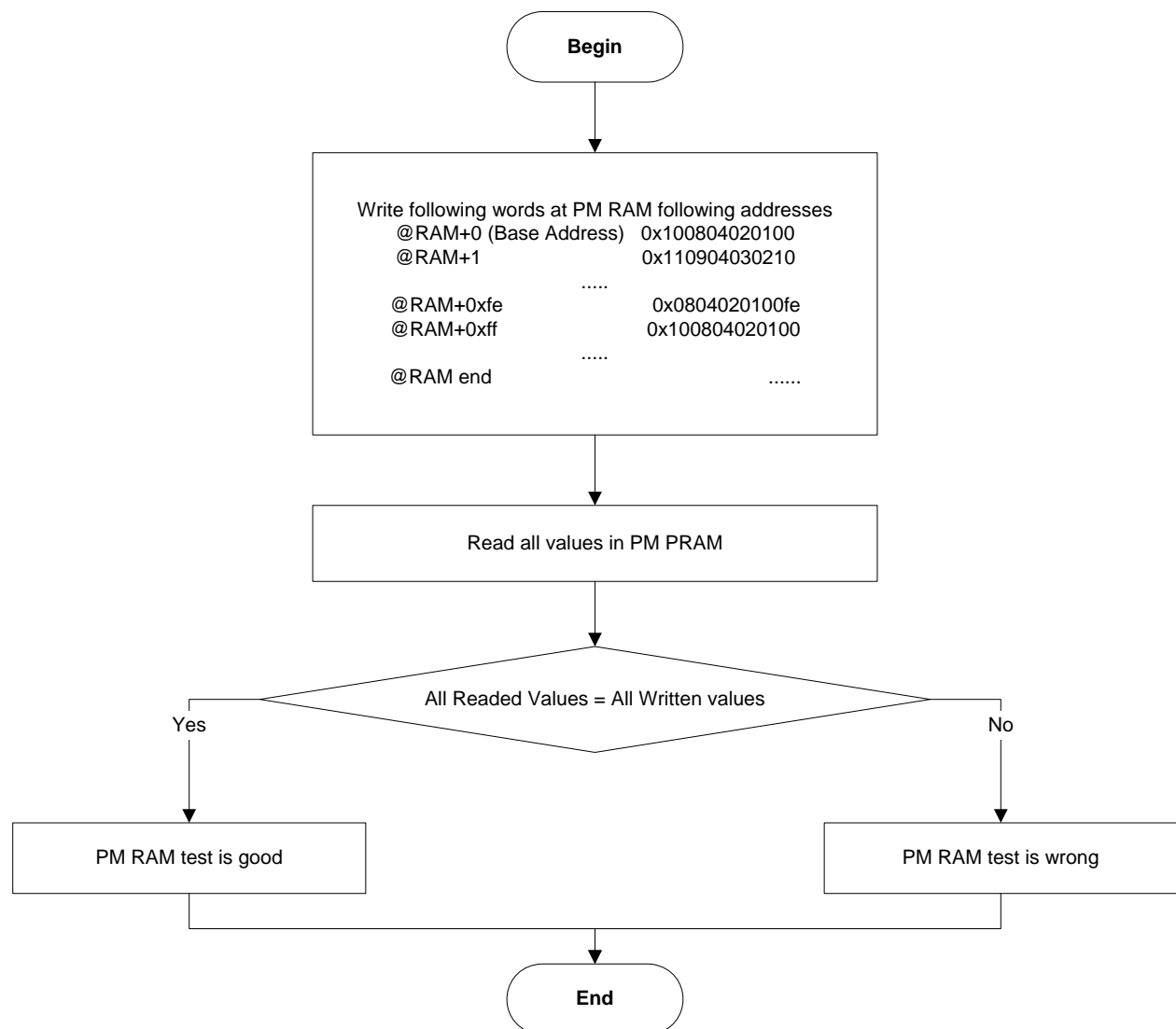

Figure 8-4: Test PM RAM algorithm

The diagnostic PM RAM words from TM(3, 26) will report:

- An approximative position of the errors found: a table of 128 words of 16 bits, each bit corresponds to a PM RAM memory block (one block size is equal to 64 words of 48 bits of PM RAM memory). See "Boot software Diagnostic – Applicative Software Diagnostic". One bit set means that a error was detected inside the block.



- A precise position for the first 16 addresses: a table of 32 words of 16 bits. Each couple of words represents a bad address MSB (for first word) and LSB (for second word). See *“Boot software Diagnostic – Applicative Software Diagnostic”*.

Cautions and Warnings

This test will erase the content of the PM RAM memory. The applicative software needs next to be transferred EEPROM → RAM even if it was previously transferred before the test. This operation will happen automatically if lookup table: parameter **“LU=SW_AUTO_FUNCTION”** bit **“Boot mode applicative software transfer EEPROM→RAM”** is active.

8.3.13. Hardware Test: test DM RAM (BSW ONLY)

Test DM RAM test the RAM DM memory. This test can be launched:

- by telecommand TC(8, 4) **“Test DM RAM”**
- autonomously at boot startup: the lookup table parameter **“LU=SW_AUTO_FUNCTIONS”** **“Boot autonomous hardware tests”** shall be set.
See Appendix 1 *“Lookup Table”*.

At the completion of the test, a diagnostic packet TM(3,26) **“Boot Software Diagnostic”** is sent. Test result can be seen on the **“Diagnostic DM Ram”** field. This procedure is written in assembly because C code requires DM RAM for variables (stack).

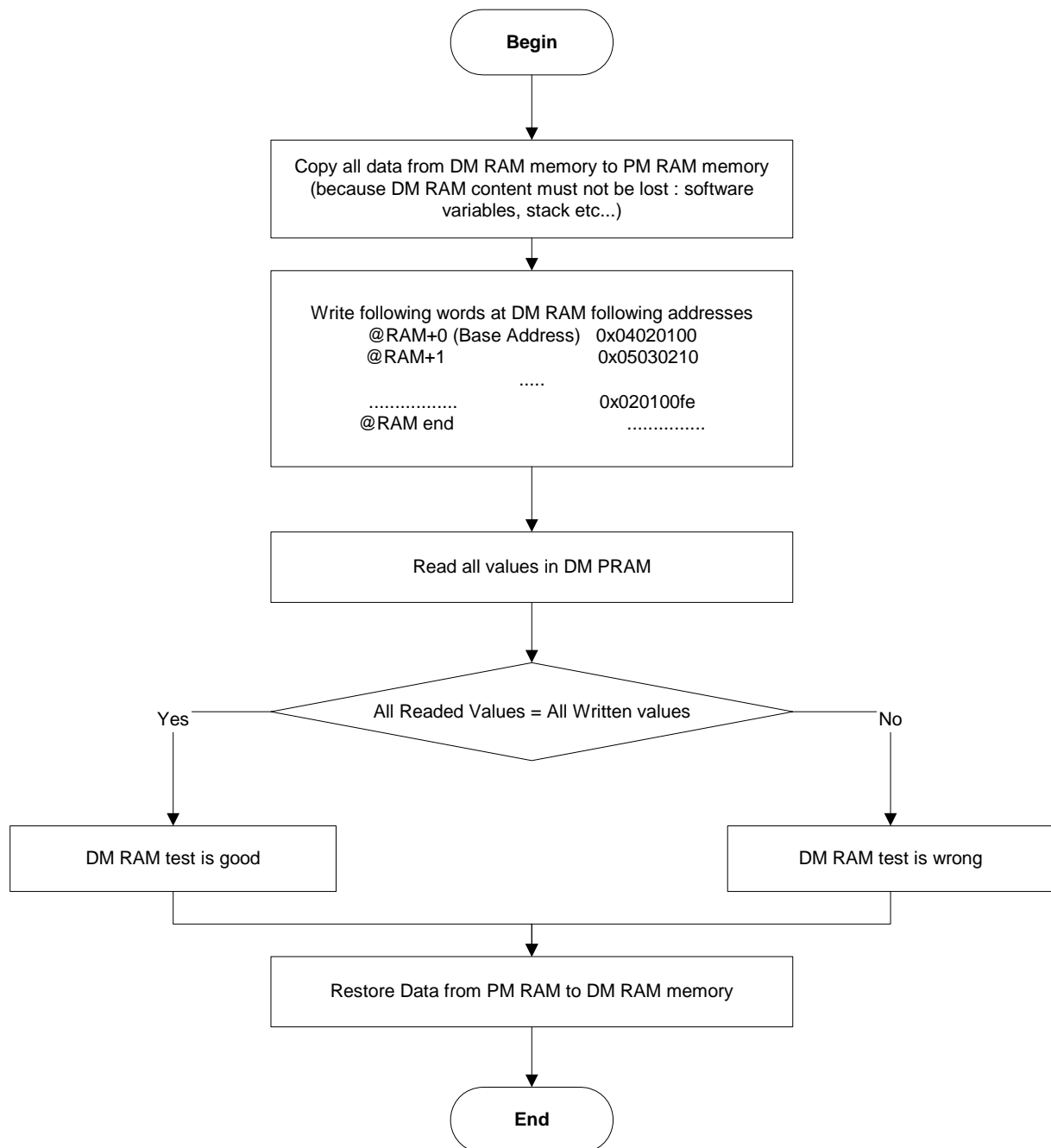

Figure 8-5: Test DM RAM algorithm

The diagnostic DM RAM words from TM(3, 26) will report:

- If test is successful. See “*Boot software Diagnostic – Applicative Software Diagnostic*”.
- If restoration of data from PM RAM memory to DM RAM memory is successful. See “*Boot software Diagnostic – Applicative Software Diagnostic*”.

Cautions and Warnings

This test needs to store DM RAM data to PM RAM data. It will then erase the content of the PM RAM memory. The applicative software needs next to be transferred EEPROM → RAM even if it was previously transferred before the test. This operation will happen automatically if lookup



table: parameter “LU=SW_AUTO_FUNCTION” bit “Boot mode applicative software transfer EEPROM→RAM” is active.

8.3.14. Hardware Test: test DM EEPROM

Eeprom configuration is explained at 8.3.33.

Test DM EEPROM test the EEPROM memory. This test can be launched:

- by telecommand TC(8, 4) “Test DM EEPROM”
- autonomously at boot or applicative startup: the lookup table parameter “LU=SW_AUTO_FUNCTIONS” “Boot autonomous hardware tests” or “Applicative autonomous hardware tests” shall be set. See Appendix 1 “Lookup Table”.

At the completion of the test, a diagnostic packet TM(3,26) “Boot Software Diagnostic” or “Applicative Software Diagnostic” is sent. Test result can be seen on the “Diagnostic DM EEPROM” field.

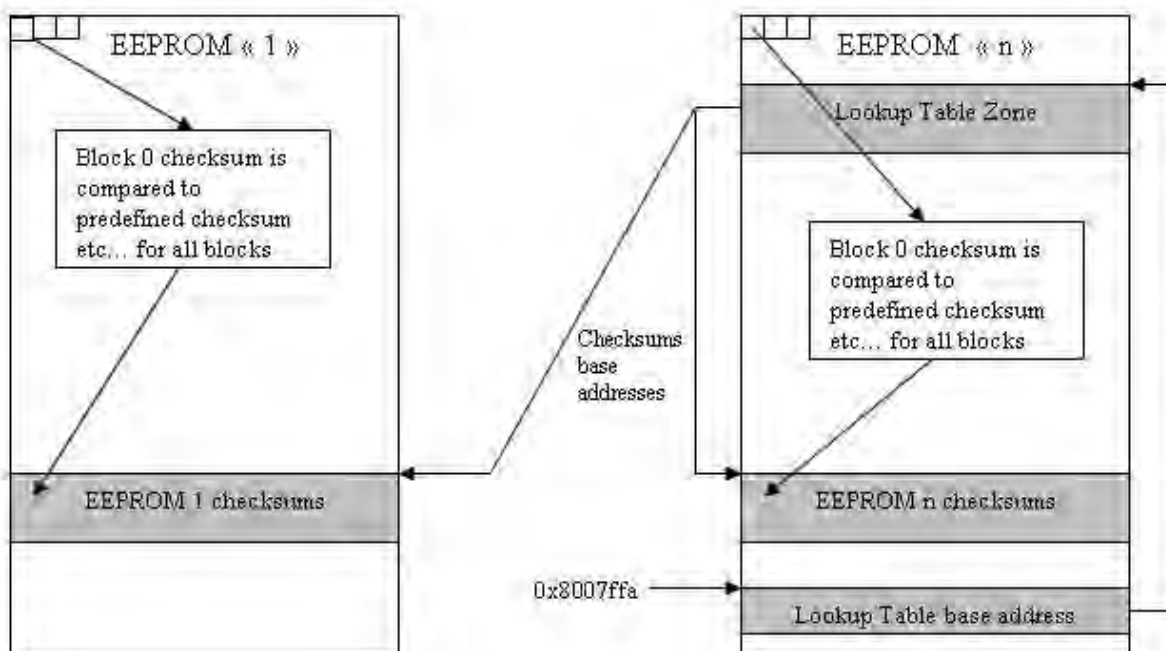

Figure 8-6: Test DM EEPROM

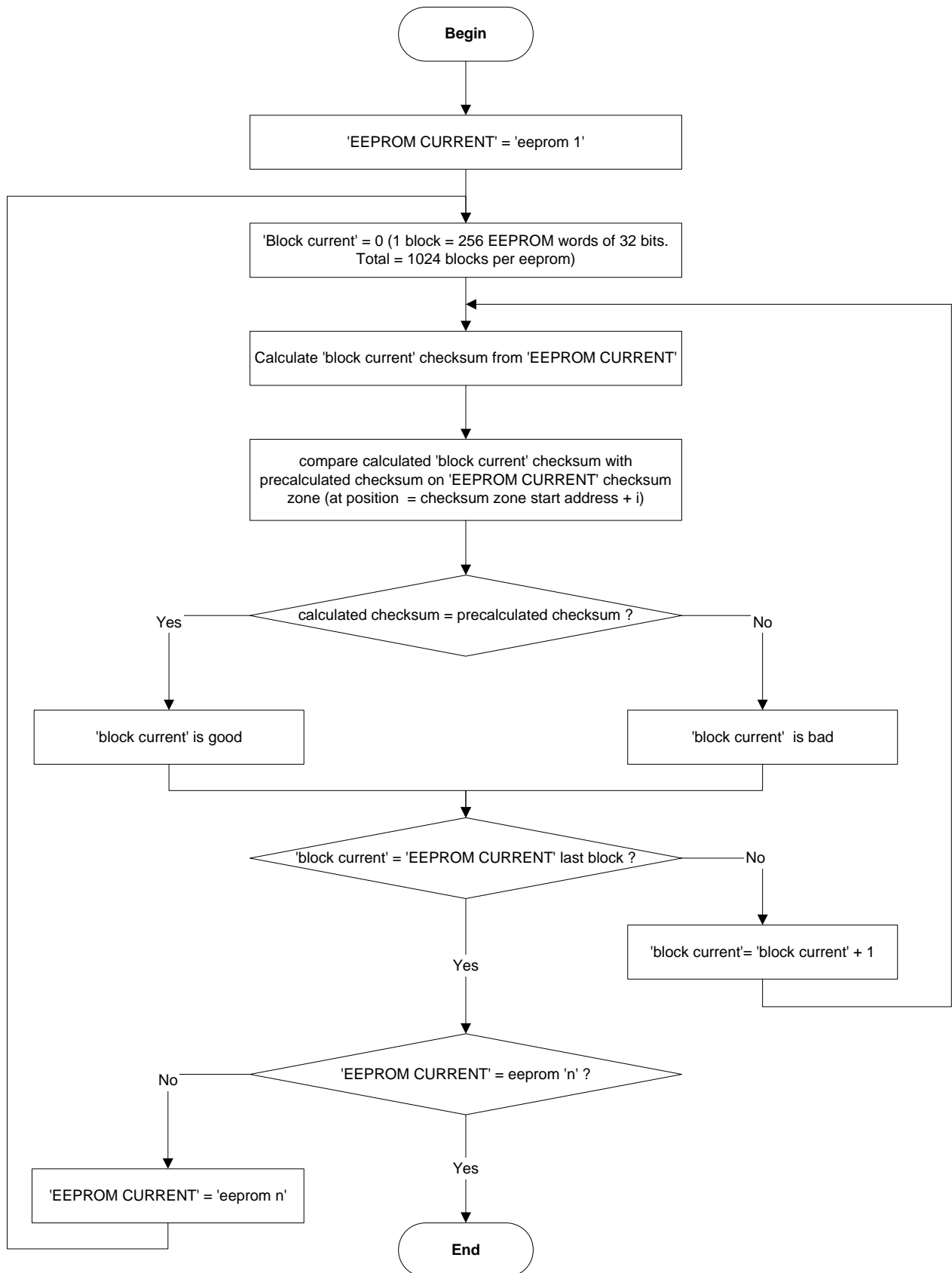

Figure 8-7: Test DM EEPROM algorithm



The diagnostic DM EEPROM words from TM(3, 26) will report an approximative position of the errors found: a table of 128 words of 16 bits, each bit corresponds to a DM EEPROM memory block (one block size is equal to 256 words of 32 bits of DM EEPROM memory). See “*Boot software Diagnostic – Applicative Software Diagnostic*”. One bit set means that an error was detected inside the block.

8.3.15. Hardware Test: test FPGA (BSW ONLY)

Test the FPGA embedded in the electronics board. See Chapter 10 and AD07 “*TM(3,26): Diagnostic Parameter Report*” for list of tests description.

This test can only be launched automatically at boot startup. Lookup table parameter “[LU=SW_AUTO_FUNCTIONS](#)” “[Boot autonomous hardware tests](#)” shall be set. See Appendix 1 “*Lookup Table*”.

At the completion of this test (and other tests of boot startup), a diagnostic packet TM(3,26) “*Boot Software Diagnostic*” is sent. Test result can be seen on the “*Diagnostic FPGA*” field.

The test is explained on AD07 “*Diagnostic Parameter Report*”.

8.3.16. Hardware Test: test 1553 (BSW ONLY)

Test the 1553 component embedded in the electronics board. See Chapter 10 and AD07 “*TM(3,26): Diagnostic Parameter Report*” for list of tests description.

This test can only be launched automatically at boot startup. Lookup table parameter “[LU=SW_AUTO_FUNCTIONS](#)” “[Boot autonomous hardware tests](#)” shall be set. See Appendix 1 “*Lookup Table*”.

At the completion of this test (and other tests of boot startup), a diagnostic packet TM(3,26) “*Boot Software Diagnostic*” is sent. Test result can be seen on the “*Diagnostic 1553*” field.

The test is explained on AD07 “*Diagnostic Parameter Report*”.

8.3.17. Hardware Test: test external timers (ASW ONLY)

Test the 9 external counters (component embedded in the electronics board) and the internal FPGA counter. See Chapter 10 and AD07 “*TM(3,26): Diagnostic Parameter Report*” for list of tests description.

This test can only be launched automatically at applicative software startup. Lookup table parameter “[LU=SW_AUTO_FUNCTIONS](#)” “[Applicative autonomous hardware tests](#)” shall be set. See Appendix 1 “*Lookup Table*”.

This tests consists of launching each counters independently for a certain amount of time defined in lookup table “[SW_TEST_EXT_TIMER_LENGTH](#)” and “[SW_TEST_FPGA_TIMER_LENGTH](#)”. If a counter did not reach the count value defined in lookup table an error will be set and reported on diagnostic packet.

8.3.18. Hardware Test: test ADC (ASW ONLY)

Test if one or both analog digital converter is busy. The status of both ADC is reported on field “*Fault Status OBSW*” (bits “*ADC Nominal Busy*” and “*ADC Redundant Busy*”) of TM(3, 25). See Chapter 10 and AD07 “*TM(3,25): Housekeeping Parameter Report*”.



ADC test can be performed when applicative software starts and is also performed during applicative software execution.

The VGAIN test sensor is used to perform the ADC test. Other test sensors (calibration1, calibration2, Voff) are not used within the software algorithms but are only reported to telemetry.

8.3.19. Applicative Software Transfer (BSW ONLY)

Functional Description

When software starts in boot mode, applicative software shall be loaded before being started. It is mainly stored in EEPROM memory at an address specified on lookup table: parameter “[LU=SW_ASW_ADR](#)” See Appendix 1 “Lookup Table”.

The task of this operation is to copy applicative software from EEPROM memory where it is stored to RAM PM memory where it must be executed next.

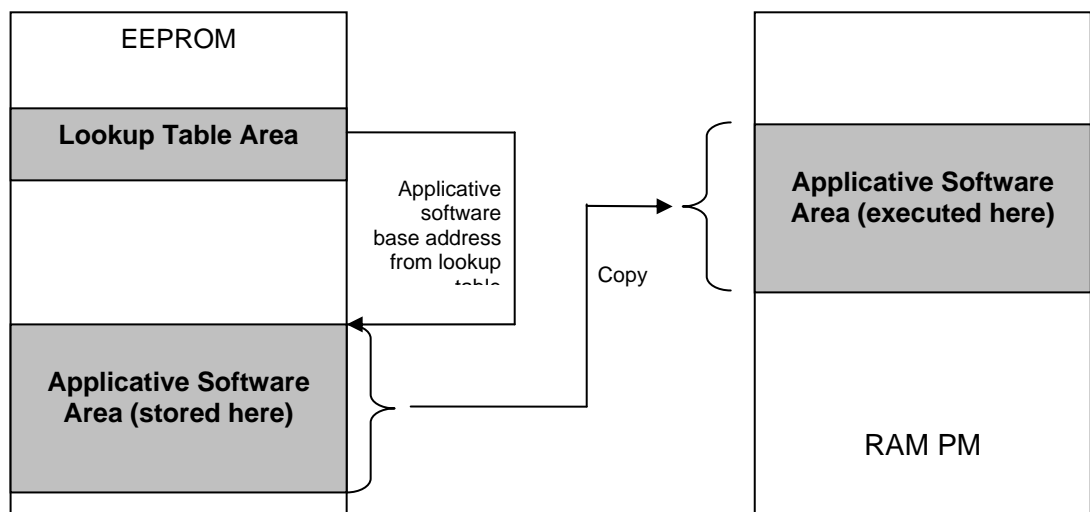
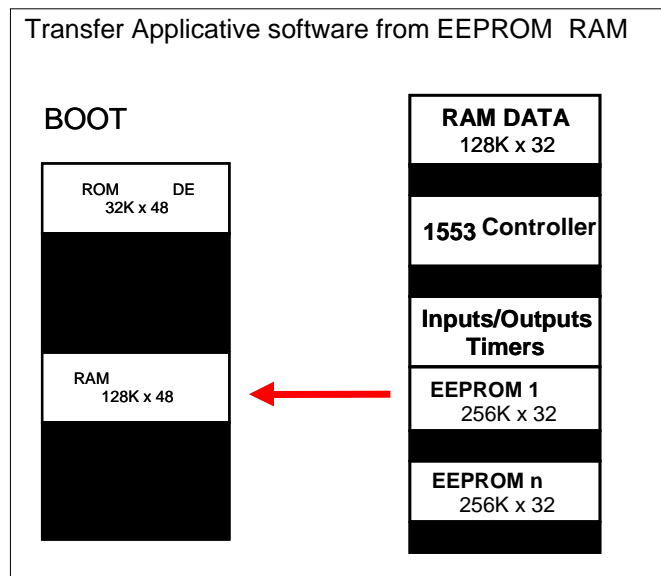

Figure 8-8: Applicative Software EEPROM to RAM



Applicative software structure on EEPROM is specified in 8.2.2

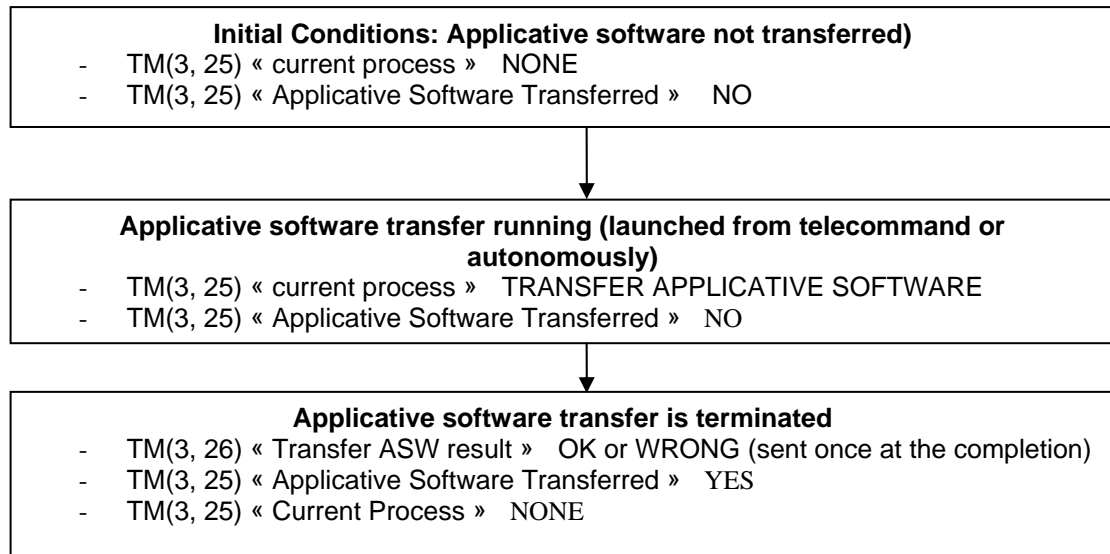

Figure 8-9: applicative software transfer telemetries

The applicative software transfer is performed thanks to the TC(8, 4) “Transfer Applicative Software” telecommand on boot mode only. This operation can also be performed automatically at boot software startup by enabling the corresponding flag on lookup table: parameter “[LU=SW_AUTO_FUNCTION](#)” bit “[Boot mode applicative software transfer EEPROM→RAM](#)”. Autonomous transfer can also be disabled with the same bit.

During transfer, the parameter “Current Process” from “boot software housekeeping” packet TM(3, 25) is set to “transfer applicative software”.

At the completion of transfer, the parameter “Transfer ASW Result” from “Boot Diagnostic” packet TM(3, 26) will report the status of the transfer : good or wrong (according to a checksum comparison). Also the parameter “Applicative Software Transfer” from “boot software diagnostic” packet TM(3, 25) will be cleared indicating that the transfer has been performed (it does not indicate that the transfer was successful or not).

Cautions and Warnings

An image of the Applicative software must be previously copied on EEPROM memory. Such an operation must be performed once only. Next applicative software will be stored on EEPROM and will not be lost even if software is switched off.

The applicative software copy on EEPROM is performed by launching a number of TC(6, 2) “memory load” from a file generated from the following operations:

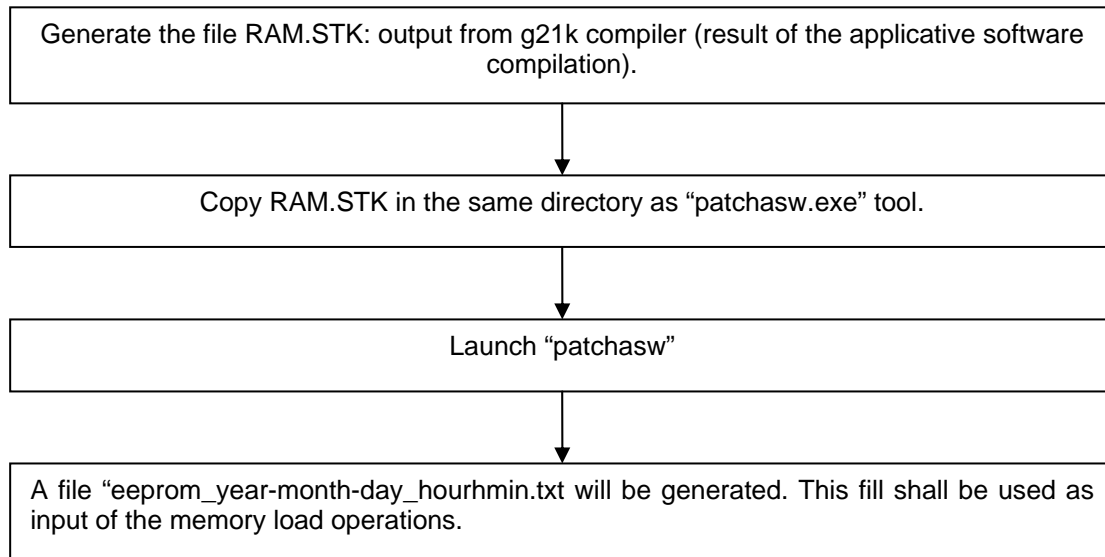

Figure 8-10: generate an Applicative Software Image for EEPROM

Several versions of applicative software can be stored on EEPROM at different addresses (beware of overlaps...). Next, the applicative software can be selected by changing the "Applicative Software Base Address" on lookup table "[LU=SW_ASW_ADR](#)".

8.3.20. Stop Process



This telecommand shall be used only in case of software stuck. In nominal operation whatever the mode, it does not need to be launched.

Telecommand description: See *AD07 @ "TC(8,4): Perform Activity of Function"*.

This telecommand is needed on the following case:

- autonomous applicative software EEPROM → RAM is set: lookup table: parameter "[LU=SW_AUTO_FUNCTION](#)" bit "[Boot mode applicative software transfer EEPROM→RAM](#)"
- Applicative software transfer EEPROM → RAM never finishes (this might happen if first words of applicative software area on EEPROM are wrong).

In that case, the "Stop Process" telecommand can be launched in order to stop applicative software transfer. Next, the applicative software (or a part of it) stored on EEPROM must be reloaded from ground to restart in a clean state.

This telecommand can also break memory operations: memory load, memory check and memory dump. Memory operations will be stopped as soon as "Stop Process" telecommand is received. This needs to be handled with care: it is preferable to let the process stop by itself.



8.3.21. Mode Change telecommands

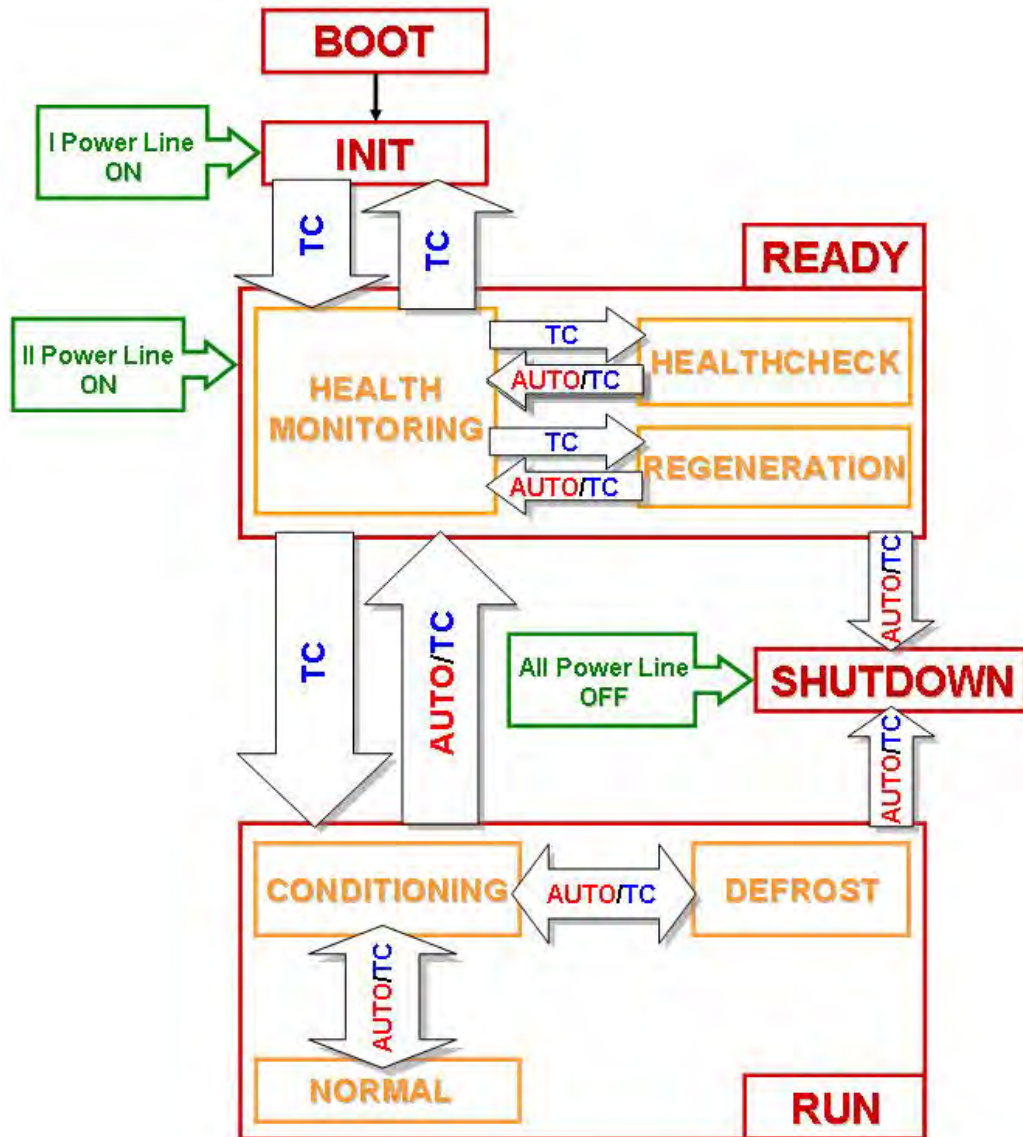

Figure 8-11: Operating Modes

Telecommand name	Action
Go to Boot	Request entrance to boot mode (launch boot software)
Go to Init	Request entrance to init mode (launch applicative software)
Go to Health Monitor	Request entrance to Health Monitor state from Ready mode
Go to Health Check	Request entrance to Health Check state from Ready mode
Go to Regeneration	Request entrance to Regeneration state from Ready mode
Go to Startup	Request entrance to Startup state from Run mode
Go to Defrost	Request entrance to Defrost state from Run mode
Go to Normal	Request entrance to Normal state from Run mode
Go to Shutdown	Request entrance to Shutdown mode

Table 8-15. Mode Change telecommands

Those telecommands must follow the conditions described in Chapter 10 (TC conditions).



Short mode description:

Boot mode:

The system enters in boot mode when electronics is switched on. The applicative software is transferred from EEPROM to RAM PM within this mode. A series of hardware tests can be performed manually or autonomously. No sensor is read. All PS-ICD services are available. 28 volts line is off.

Init mode:

The system enters in init mode from telecommand. The sensors on electronics (voltage, intensity, electronics temperature, test) are read and reported to telemetry. Several hardware tests can be performed autonomously when mode starts. 28 volts line is still off.

Ready mode:

The system enters in ready mode from telecommand or autonomously in case of failure of more advanced modes. 28 volts line is switched on when mode starts. All sensors are read (including sorption cooler electronics and pressure) and reported to telemetry. Two procedures can be launched:

- health check : heaters and sensors tests
- regeneration.

Run mode:

The system enters in run mode from telecommand. The sorption cooler cycling starts initially in startup (startup is launched automatically when run mode starts). From startup, the system can transition to defrost or normal mode depending on triggers (see 8.3.26). Nominal operation occurs during normal mode: the system should stay within this mode. A failure detection is performed continuously during run mode and recovery scenarios are executed in case of failure detection (from example removal of a bed). Most of FDIR procedures are performed in run mode. In startup mode, cycle transitions depends on triggers such as sensors values and is used to launch the sorption cooler. Defrost mode is very similar as startup except that two heaters are activated. In normal mode, cycle transitions depends on a fixed time value

Shutdown mode:

The system enters in shutdown mode from telecommand or autonomously after failure detection. This mode is very similar to ready mode (but 28 volts is switched off by the satellite) and is usually reached autonomously when a failure was detected. Chapters relative to FDIR (from 0) describe the autonomous transition to shutdown.

8.3.22. Operations available on all modes

The following operations are available on all modes for boot and applicative software:

1. Memory operations.
2. Time Management.
3. Generation of telemetry packets.
4. Connection test.



8.3.23. Boot Mode Description

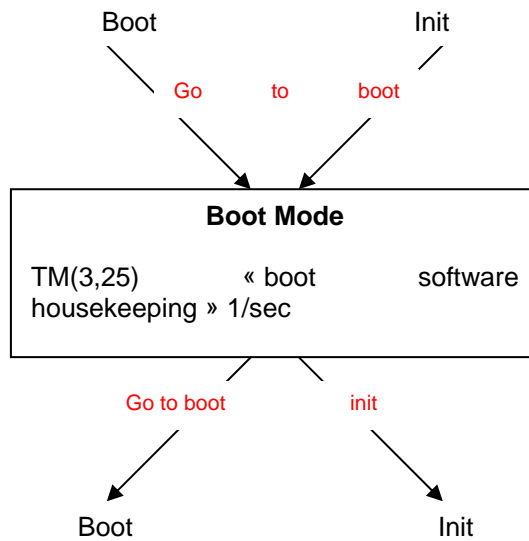

Figure 8-12: Boot mode transitions

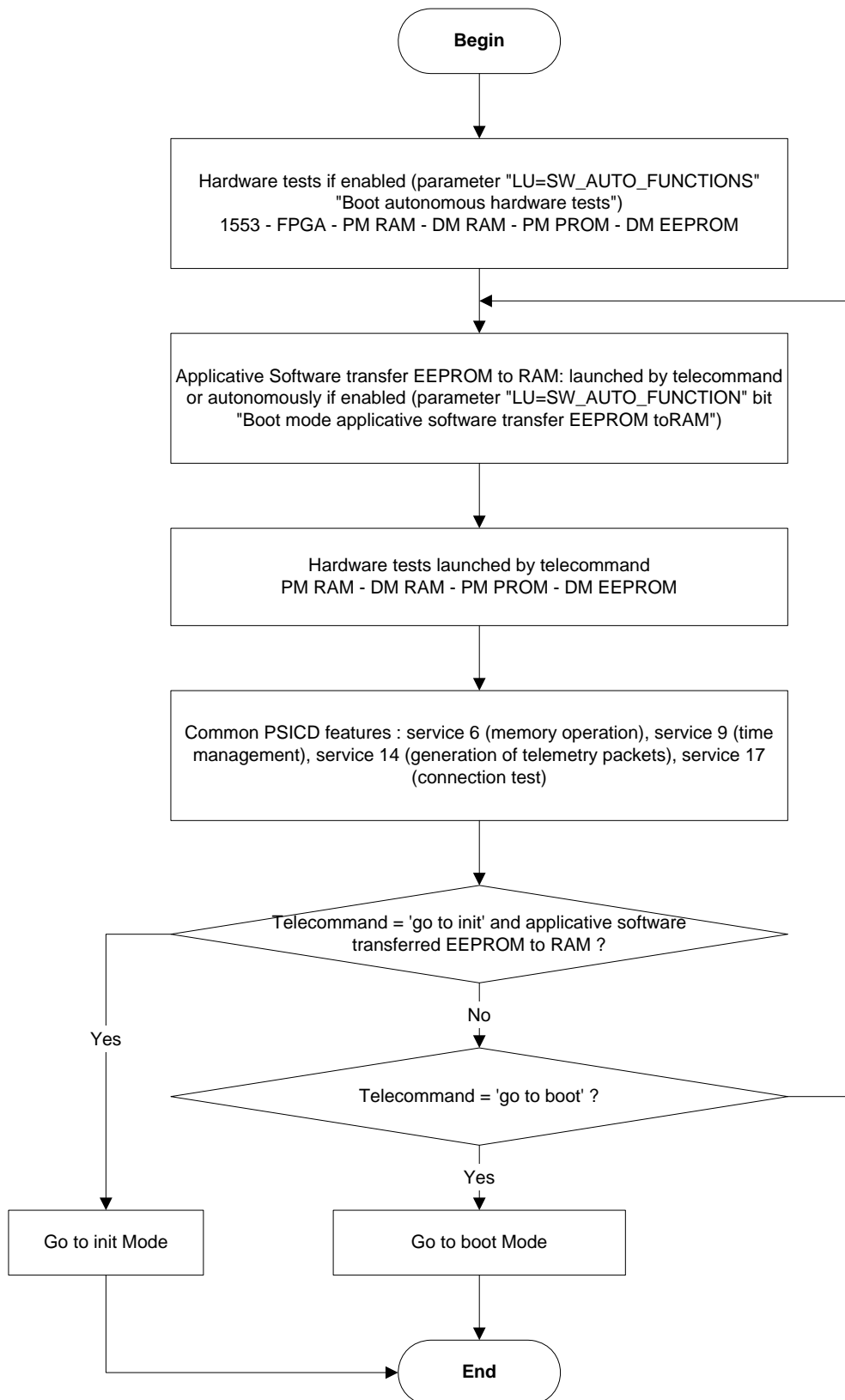

Figure 8-13: Boot mode main features



The boot mode is entered automatically at sorption cooler electronics switch on. It can also be reached by the “go to boot” telecommand from boot or init mode: reset of the DSP is performed and boot mode is launched from scratch.

When boot mode starts, a series of hardware tests can be launched if the following lookup table parameter “LU=SW_AUTO_FUNCTIONS” “Applicative autonomous hardware tests” is set.

List of hardware tests launched at boot startup:

- 1553 test
- FPGA test
- PM PROM memory test
- PM RAM memory test
- DM RAM memory test
- DM EEPROM memory test

Following this hardware tests step, telecommand can be launched.

Next, the applicative software is transferred from EEPROM → RAM autonomously if lookup table parameter “LU=SW_AUTO_FUNCTION” bit “Boot mode applicative software transfer EEPROM→RAM” is set or by telecommand. **This operations needs to be performed to launch the applicative software.**

The following hardware tests can be launched by telecommand:

- PM PROM memory test
- PM RAM memory test
- DM RAM memory test
- DM EEPROM memory test

To exit boot mode, the “go to boot” or “go to init” telecommand must be launched respecting conditions described in *Chapter 10 and AD07“TC conditions”*.

8.3.24. Init Mode Description

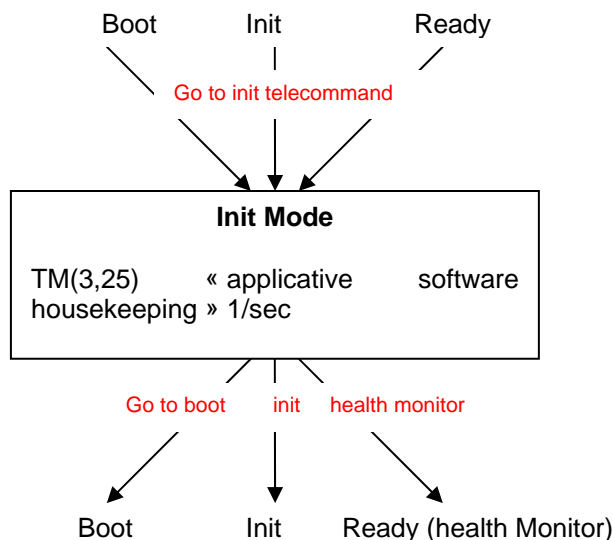

Figure 8-14: Init mode transitions

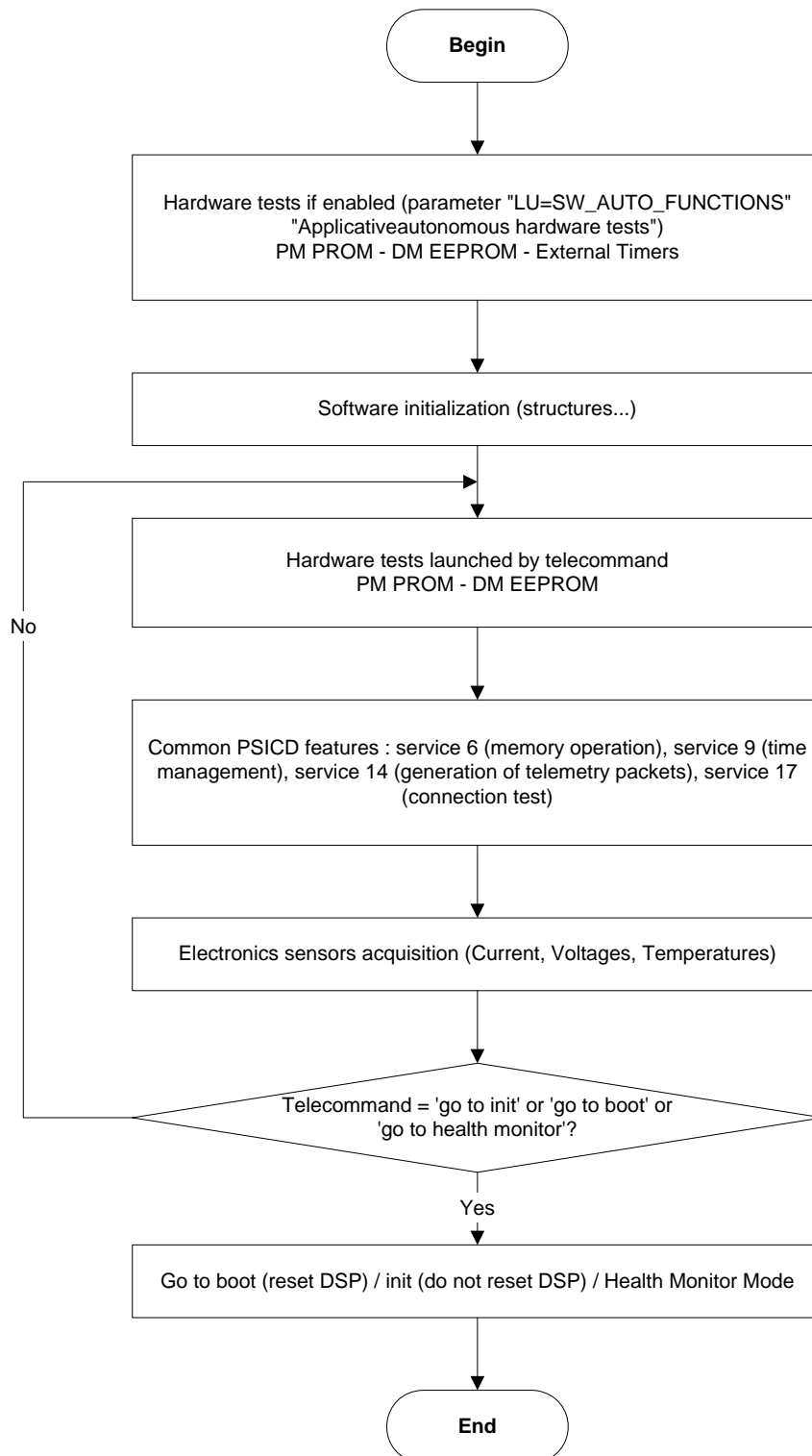

Figure 8-15: Init mode main features

The init mode is reached by the “go to init” telecommand from boot, init or ready mode: if transition boot → init, reset of the DSP is performed and PM PROM and PM RAM memory will be swapped in order to execute the applicative software previously stored in PM RAM memory.

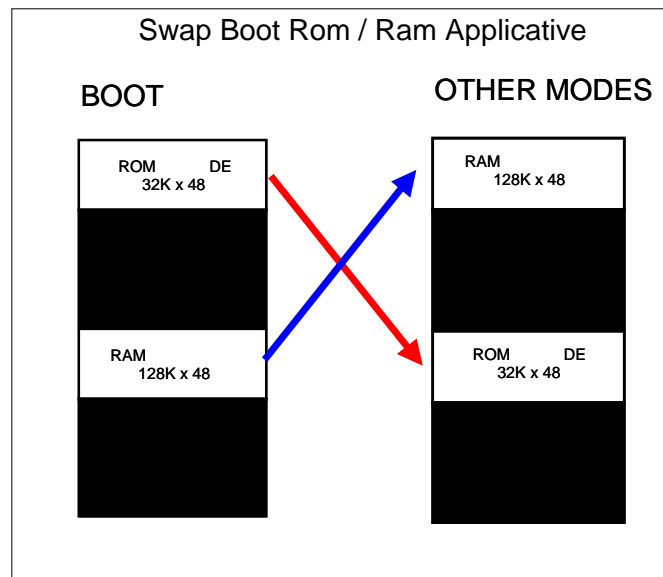

Figure 8-16: Swap PM PROM / PM RAM

When init mode starts, a series of hardware tests can be launched if the following lookup table parameter “[LU=SW_AUTO_FUNCTIONS](#)” “[Applicative autonomous hardware tests](#)” is set.

List of hardware tests launched at init startup:

- PM PROM memory test
- DM EEPROM memory test
- External Timers
- ADC Busy

Next software initializations are performed. Following these steps, telecommand can be launched.

The following hardware tests can be launched next by telecommand:

- PM PROM memory test
- DM EEPROM memory test

Electronics sensors are read and reported to telemetry:

- Voltages
- Intensity
- Electronics temperatures

To exit init mode, the “go to boot”, “go to init”, “go to health check” telecommand must be launched respecting conditions described in *AD07 @ “TC conditions”*.



8.3.25. Ready Mode Description

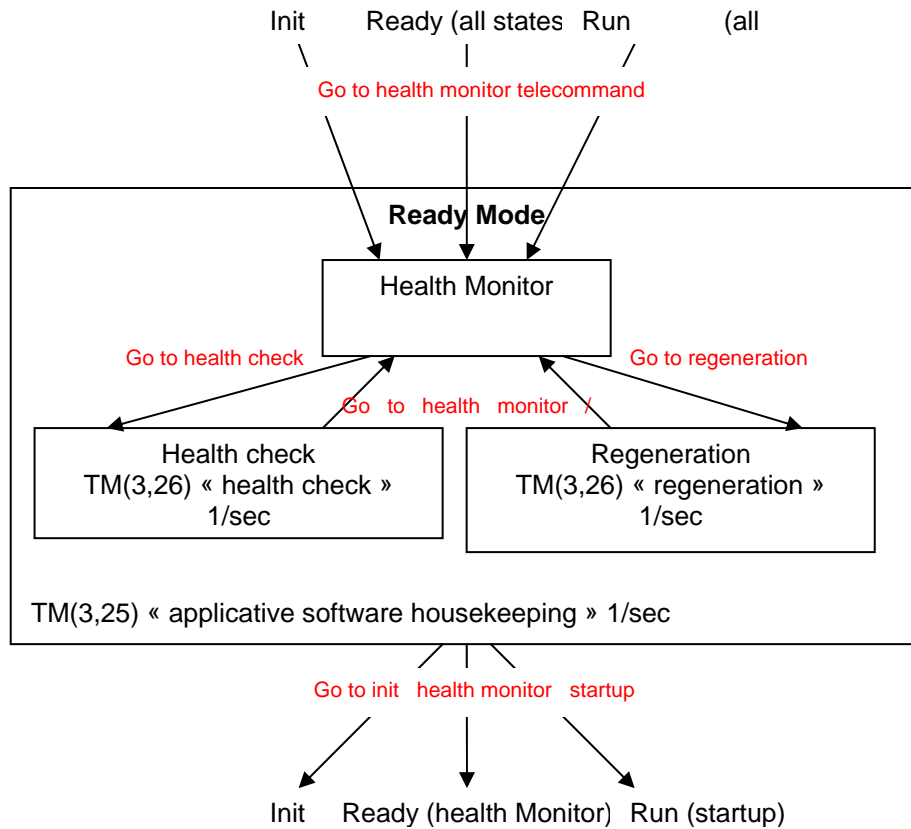

Figure 8-17: Ready mode transitions

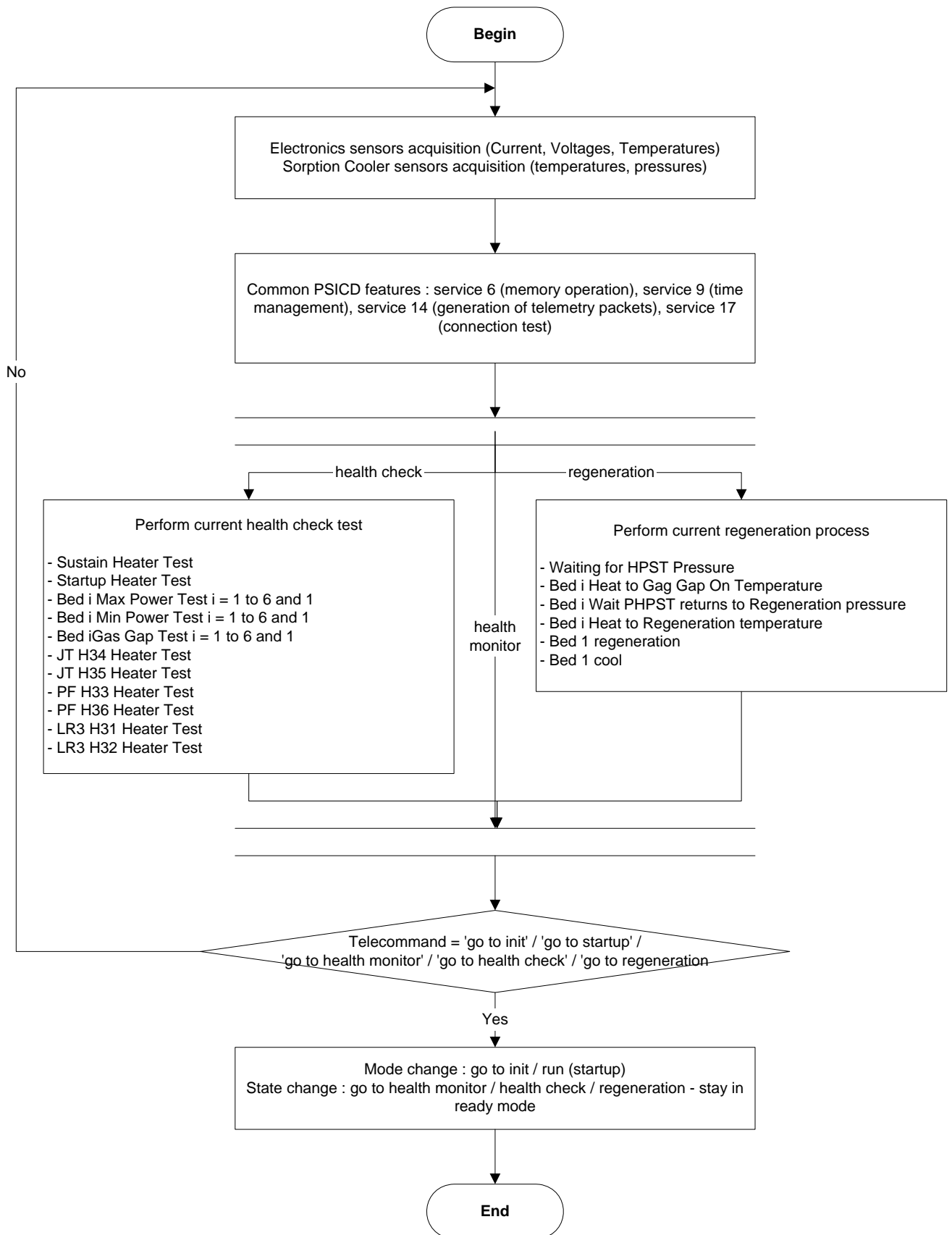

Figure 8-18: Ready mode main features



The ready mode is reached by the “go to health monitor” telecommand from init, ready, run or shutdown mode. After a transition from init → ready mode the 2^d power line (which provides power to the Sorption Cooler) is switched on by the CDMS (the CDMS use the “enter health monitor” event to switch on the 2^d power line).

The ready is divided into three states:

- health monitor
- health check
- regeneration

During these states, the following operations are performed:

- Electronics sensors acquisition and reported telemetry:
 - o Voltages
 - o Intensity
 - o Electronics temperatures
- Sorption cooler sensors are read and reported to telemetry:
 - o Temperatures
 - o Pressures

Health monitor state

This state is launched when transition from one mode to ready mode. It is mainly used to acquire all sensors and report their values to telemetry.

Health check state

Healthcheck procedure is described in 8.5.1.

Health check state is entered following a “go to health check” telecommand from the “health monitor” state. During health check state, a periodic diagnostic TM(3,26) “health check diagnostic” is sent once a second reporting the test that currently runs and the previous tests status (since beginning of the health check procedure). The result of the overall health check procedure is given on the last TM(3, 26) diagnostic sent following the transition health check → health monitor.

When all Health Check tests are terminated, the software automatically returns to Health Monitor state. Nevertheless, it is possible to break Health Check procedure manually and return to Health Monitor state with the “go to health monitor” telecommand.

Lookup table parameters applied to Healthcheck procedure: see 8.5.1 and *Appendix1 “Lookup Table”*.

Lookup Table Parameter	Use
HEALTHCHECK_DELTA_P_LP	See 8.5.1 Δ PLP
HEALTHCHECK_TIME_LIMIT	See 8.5.1 $time_{limit}$
HEALTHCHECK_TLPSB	See 8.5.1 $T_{LP-LIMIT}$
HEALTHCHECK_MAX_POWER	See 8.5.1 max power (CE)
HEALTHCHECK_MIN_POWER	See 8.5.1 min power (CE)
HEALTHCHECK_TBED_LIMIT	See 8.5.1 $T_{BED-LIMIT}$
HEALTHCHECK_PBED_LIMIT	See 8.5.1 $P_{BED-LIMIT}$
HEALTHCHECK_DELTAT_COLD	See 8.5.1 ΔT_{COLD}
HEALTHCHECK_TIME_LIMIT_COLD	See 8.5.1 $time_{limit-cold}$

Table 8-16. Lookup table parameters used for Health Check



IMPORTANT:

HEALTHCHECK Step1, LPSB H7 Sustain Heater Test, is performed by using power value 0x48 POWER_LPSB and NOT H7 max power.

Regeneration state

Regeneration procedure is described in 8.5.2.

Regeneration state is entered following a “go to regeneration” telecommand from the “health monitor” state. During regeneration state, a periodic diagnostic TM(3,26) “regeneration diagnostic” is sent once a second reporting the regeneration process that currently runs and the previous processes status (since beginning of the regeneration procedure). The result of the overall regeneration procedure is given on the last TM(3, 26) diagnostic sent following the transition regeneration → health monitor.

When all Regeneration processes are terminated, the software automatically returns to Health Monitor state. Nevertheless, it is possible to break Regeneration procedure manually and return to Health Monitor state with the “go to health monitor” telecommand.

Lookup table parameters applied to Regeneration procedure: see *Appendix “Lookup Table”*.

Lookup Table Parameter	Use
REGENERATION_POWER	See 8.5.2 POWER_REGEN
REGENERATION_TEMPERATURE	See 8.5.2 REGEN_TEMPERATURE
REGENERATION_MAX_PRESSURE	See 8.5.2 MAX_REGEN_PRESSURE
REGENERATION_TIME	See 8.5.2 REGEN_TIME
REGENERATION_MAX_TIME	See 8.5.2 MAX_REGEN_TIME
REGENERATION_GGON_TEMPERATURE	See 8.5.2 GGA_ON_TEMPERATURE
REGENERATION_DELTAT	See 8.5.2 “Step 5 → +10K – Step 6 → ± 10K”

Table 8-17. Lookup table parameters used for regeneration



8.3.26. Run Mode Description

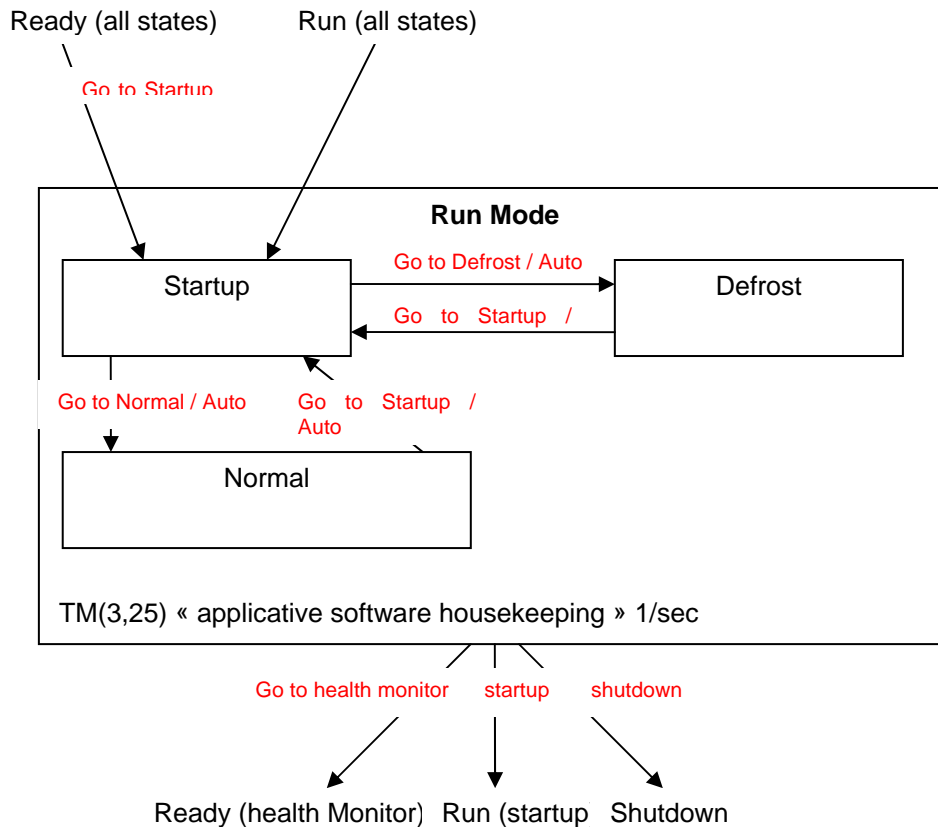

Figure 8-19: Run mode transitions

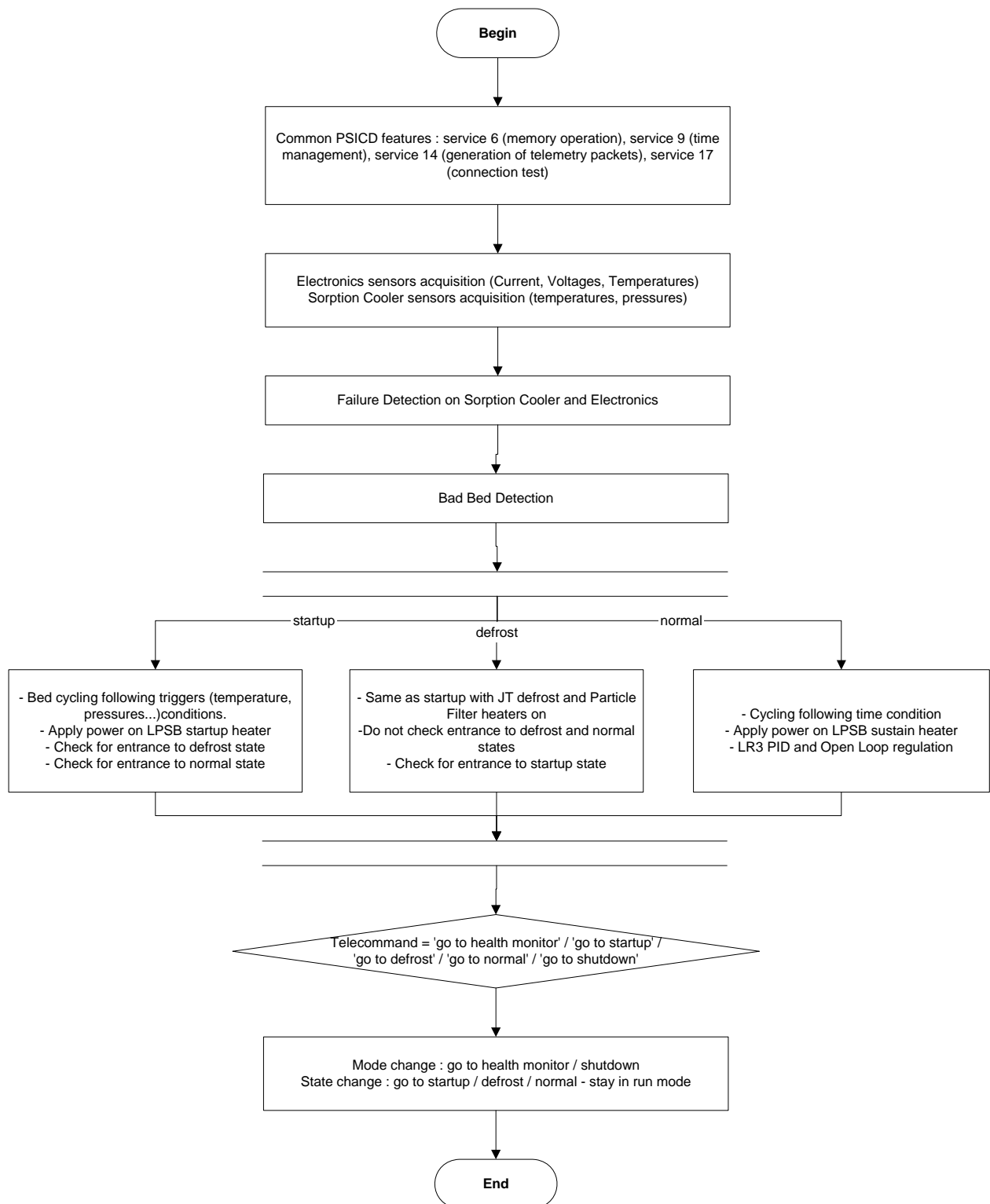

Figure 8-20: Run mode main features

The run mode is reached by the “go to startup” telecommand from ready or run mode.

The run is divided into three states:

- startup



- defrost
- normal

During these states, the following operations are performed:

- Electronics sensors acquisition and reported telemetry:
 - o Voltages
 - o Intensity
 - o Electronics temperatures
- Sorption cooler sensors are read and reported to telemetry:
 - o Temperatures
 - o Pressures
- Fault detection (FDIR). See Chapter 7.

Startup state

This state is launched when transition from one mode to run mode. It is mainly used to start the sorption cooler as quick as possible in order to reach the nominal operation: the normal mode.

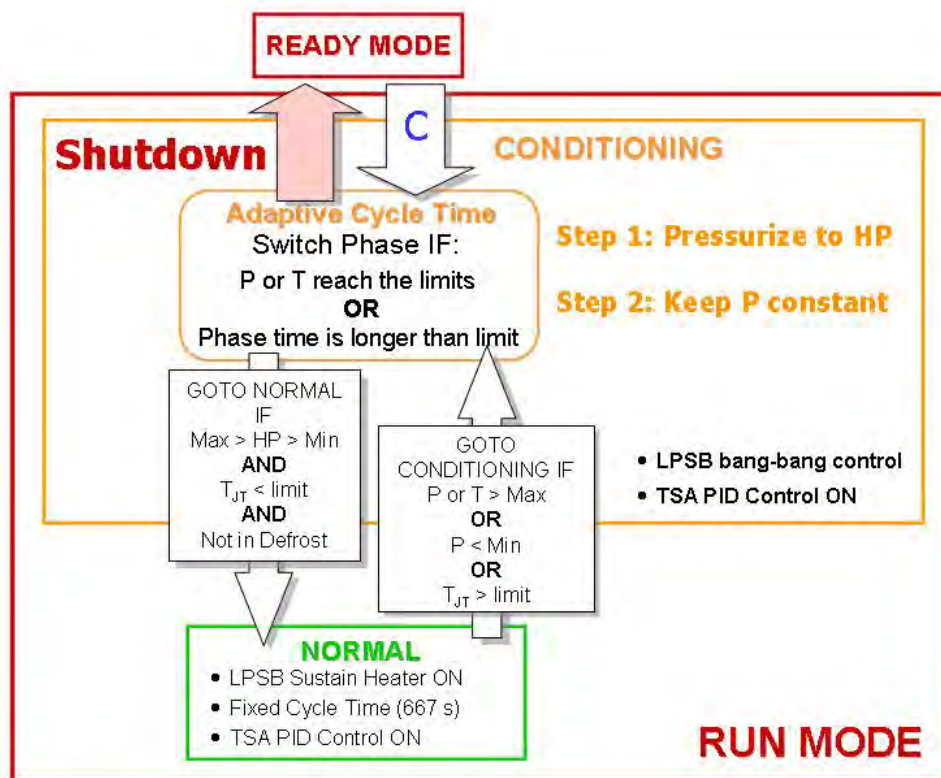

Figure 8-21: RUN Mode

The following lookup table parameters are used in startup state:

Lookup table parameter	Use
STARTUP_TIME_ADJUST_MDP	Cycle change condition: pressure limit
STARTUP_TIME_ADJUST_MDT	Cycle change condition: temperature limit of desorb bed



STARTUP_TIME_ADJUST_MHT	Cycle change condition: temperature limit of heatup bed
STARTUP_TIME_ADJUST_MCTFIRST	Time out for the first startup cycle
STARTUP_TIME_ADJUST_MCTNEXT	Time out for all next startup cycles
STARTUP_ENTER_DEFROST_MTP	Startup → Defrost condition: HPST pressure limit
STARTUP_ENTER_DEFROST_MJT_T7	Startup → Defrost condition: JT temperature limit (if T7 good)
STARTUP_ENTER_DEFROST_MJT_T30	Startup → Defrost condition: JT temperature limit (if T7 bad)
STARTUP_ENTER_DEFROST_FLOW	Defrost entrance condition: flow
STARTUP_ENTER_NORMAL_MCONJT_T7	Startup → Normal condition: JT temperature limit (if T7 good)
STARTUP_ENTER_NORMAL_MCONJT_T30	Startup → Normal condition: JT temperature limit (if T7 bad)
STARTUP_ENTER_NORMAL_MINCONJT	Startup → Normal condition: HPST pressure limit min
STARTUP_ENTER_NORMAL_MAXCONJT	Startup → Normal condition: HPST pressure limit max
POWER_HEATUP_BEDS_STARTUP	Heatup bed 0 power in startup and defrost
POWER_HEATUP_BEDS_STARTUP+1	Heatup bed 1 power in startup and defrost
POWER_HEATUP_BEDS_STARTUP+2	Heatup bed 2 power in startup and defrost
POWER_HEATUP_BEDS_STARTUP+3	Heatup bed 3 power in startup and defrost
POWER_HEATUP_BEDS_STARTUP+4	Heatup bed 4 power in startup and defrost
POWER_HEATUP_BEDS_STARTUP+5	Heatup bed 5 power in startup and defrost
POWER_DESORB_BEDS_STARTUP	Desorb bed 0 power in startup and defrost
POWER_DESORB_BEDS_STARTUP+1	Desorb bed 1 power in startup and defrost
POWER_DESORB_BEDS_STARTUP+2	Desorb bed 2 power in startup and defrost
POWER_DESORB_BEDS_STARTUP+3	Desorb bed 3 power in startup and defrost
POWER_DESORB_BEDS_STARTUP+4	Desorb bed 4 power in startup and defrost
POWER_DESORB_BEDS_STARTUP+5	Desorb bed 5 power in startup and defrost
STARTUP_HPST_PRESSURE_LIMIT	HPST pressure limit
STARTUP_LPSB_HIGH_TEMPERATURE_LIMIT	If LPSB temperature is higher than this limit, switch off LPSB heater
STARTUP_LPSB_LOW_TEMPERATURE_LIMIT	If LPSB temperature is lower than this limit, switch on LPSB heater

Table 8-18. Lookup table parameters used in Startup state

As soon run mode is reached, bed cycle starts from the state defined in “Bed Status MSB” and “Bed Status LSB” from TM(3, 25).

Nominally, the system starts from the state:

- bed 0 = heatup
- bed 1 = desorb
- bed 2 = cooldown
- bed 3, 4, 5 = absorb

It is possible to change the nominal bed state before starting (in init, ready or shutdown modes) with the

- “Set Bed State”: to set a bed to “good”, “bad” or “off normal only”. See Set Bed State telecommand.
- “Set Initial Heatup Bed Position” to select which bed will have the heatup state (the next bed will follow). See Set Initial Bed Position telecommand.

All transitions from one mode to another mode (example startup → health monitor → init) on applicative software will not change beds states. Transition from applicative software to boot software (init → boot) will reset beds states to bed 0 = heatup, bed 1 = desorb, bed 2 = cooldown, bed 3, 4 5 = absorb.

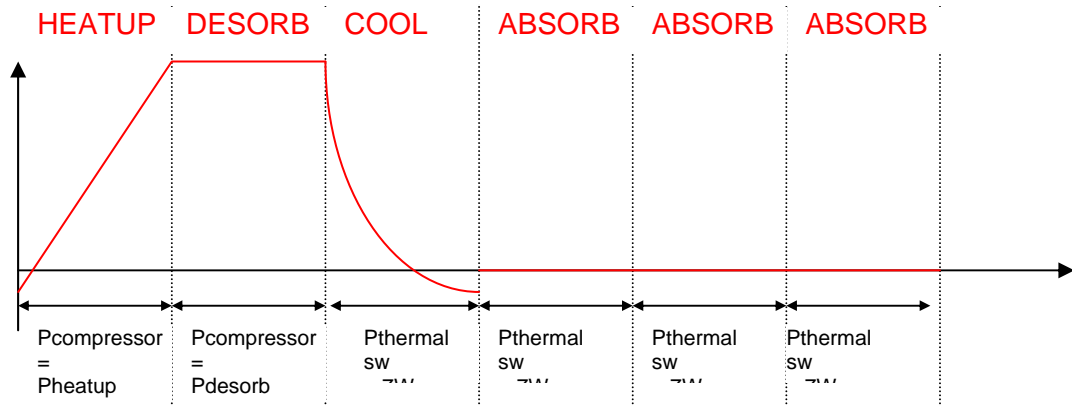

Figure 8-22. Bed cycle in startup and defrost

Beds powers:

- heatup bed is powerized at “[POWER_HEATUP_BEDS_STARTUP](#)” watts. Each bed have its own heatup power. Heatup bed gas gap is switched off.
- Desorb bed is powerized at “[POWER_DESORB_BEDS_STARTUP](#)” watts. Each bed have its own desorb power. Desorb bed gas gap is switched off.
- Cooldown and Absorb beds are not powerized. Theirs gas gaps are switched on.
- If HPST pressure is lower than a limit defined in lookup table: “[STARTUP_HPST_PRESSURE_LIMIT](#)” Heatup bed power and Desorb bed power is equal to “Heatup Power + Desorb Power” / 2.
- Bed powers can be updated every time during the cycle.
- Depending on the requested bed power (in lookup table) only one bed heater (the variable one) can be switched on if requested power is low or both bed heaters (fixed and variable) can be switched on if requested power is higher. This remarks also applies on defrost and normal modes.

Low Pressure Stabilization Bed power (bang-bang procedure):

- If LPSB temperature T18 is higher than a limit defined in lookup table: “[STARTUP_LPSB_HIGH_TEMPERATURE_LIMIT](#)”, the LPSB startup Heater H8 must be switched off.
- If LPSB temperature T18 is lower than a limit defined in lookup table: “[STARTUP_LPSB_LOW_TEMPERATURE_LIMIT](#)”, the LPSB startup Heater H8 must be switched on.
- FDIR: If H8 is bad, use H7 with power defined in lookup table: [POWER_LPSB](#).

Triggers are checked continuously to transition from one cycle to the next one. The bed cycle will change if one of the following triggers is set:

- Pressure of desorb bed is up a limit defined in lookup table: [STARTUP_TIME_ADJUST_MDP](#)
- Temperature of heatup bed is up a limit defined in lookup table: [STARTUP_TIME_ADJUST_MHT](#)
- Temperature of desorb bed is up a limit defined in lookup table: [STARTUP_TIME_ADJUST_MDT](#)
- Cycle time is up a limit defined in lookup table: [STARTUP_TIME_ADJUST_MCTFIRST](#) for first cycle when transition ready → run or [STARTUP_TIME_ADJUST_MCTNEXT](#) for all other cycles.

When end of a cycle is reached, the system will firstly check if entrance in defrost state is required. All triggers defined below shall be set to enter in defrost state:



- Defrost is enabled: set in lookup table “LU=SW_AUTO_FUNCTIONS” “Auto go to defrost”
- The system is not currently in defrost state
- JT temperature is lower than a limit defined in lookup table “STARTUP_ENTER_DEFROST_MJT_T7” if T7 sensor is good or “STARTUP_ENTER_DEFROST_MJT_T30” if T7 sensor is bad.
- HPST pressure is up a limit defined in lookup table “STARTUP_ENTER_DEFROST_MTP”
- Flow calculated is below a limit defined in lookup table “STARTUP_ENTER_DEFROST_FLOW”. Flow calculated = Heatup Power of desorb bed * last cycle time + Desorb Power of desorb bed * current cycle time. Current cycle time is the time of the cycle that has just finished.
- The current cycle is not the first one

After the defrost entrance check, the system will check entrance in normal state. All triggers defined below shall be set to enter in normal state:

- Current state is not defrost
- JT temperature is below a limit defined in lookup table: “STARTUP_ENTER_NORMAL_MCONJT_T7” if T7 is good or “STARTUP_ENTER_NORMAL_MCONJT_T30” if T7 is bad
- HPST pressure is between two limits defined in lookup table: “STARTUP_ENTER_NORMAL_MINCONJT” and “STARTUP_ENTER_NORMAL_MAXCONJT”

Defrost state

The defrost state is launched after an autonomous transition (that can be enabled or disabled with the lookup table parameter: “LU=SW_AUTO_FUNCTIONS” “Auto go to defrost”) from startup state or after the “Go to Defrost” telecommand.

The following lookup table parameters are used in defrost state:

Lookup table parameter	Use
STARTUP_EXIT_DEFROST_TIME	Defrost → Startup condition: time out to stay in defrost
STARTUP_EXIT_DEFROST_MJT_T7	Defrost → Startup condition: JT temperature limit (if T7 good)
STARTUP_EXIT_DEFROST_MJT_T30	Defrost → Startup condition: JT temperature limit (if T7 bad)

Table 8-19. Lookup table parameters used in Defrost state

The Defrost state have exactly the same characteristics that startup state (same triggers are checked, same powers...) except that the following heaters are switched on:

- JT defrost heater H33 or H36 if H33 is bad
- Particle Filter heater H34 or H35 if H34 is bad.

Continuously, the following triggers are checked to detect exit. The defrost state will be terminated if one of the trigger is set:

- Defrost time is up a limit defined in lookup table: “STARTUP_EXIT_DEFROST_TIME”
- JT temperature is up a limit defined in lookup table: “STARTUP_EXIT_DEFROST_MJT_T7” if T7 is good or “STARTUP_EXIT_DEFROST_MJT_T30” if T7 is bad.

Normal state

The normal state is launched after an autonomous transition from startup state or after the “Go to Normal” telecommand.



The following lookup table parameters are used in normal state:

Lookup table parameter	Use
POWER_HEATUP_BEDS	Heatup bed 0 power in normal
POWER_HEATUP_BEDS+1	Heatup bed 1 power in normal
POWER_HEATUP_BEDS+2	Heatup bed 2 power in normal
POWER_HEATUP_BEDS+3	Heatup bed 3 power in normal
POWER_HEATUP_BEDS+4	Heatup bed 4 power in normal
POWER_HEATUP_BEDS+5	Heatup bed 5 power in normal
POWER_DESORB_BED	Desorb bed 0 power in normal
POWER_DESORB_BED+1	Desorb bed 1 power in normal
POWER_DESORB_BED+2	Desorb bed 2 power in normal
POWER_DESORB_BED+3	Desorb bed 3 power in normal
POWER_DESORB_BED+4	Desorb bed 4 power in normal
POWER_DESORB_BED+5	Desorb bed 5 power in normal
POWER_LPSB	LPSB sustain heater (H7) power
TIME_CYCLE_NORMAL	Normal cycle time
TIME_GASGAP_ON_BEDS	Gas Gap On time from bed 0
TIME_GASGAP_ON_BEDS+1	Gas Gap On time from bed 1
TIME_GASGAP_ON_BEDS+2	Gas Gap On time from bed 2
TIME_GASGAP_ON_BEDS+3	Gas Gap On time from bed 3
TIME_GASGAP_ON_BEDS+4	Gas Gap On time from bed 4
TIME_GASGAP_ON_BEDS+5	Gas Gap On time from bed 5
TIME_GASGAP_OFF_BEDS	Gas Gap Off time for bed 0
TIME_GASGAP_OFF_BEDS+1	Gas Gap Off time for bed 1
TIME_GASGAP_OFF_BEDS+2	Gas Gap Off time for bed 2
TIME_GASGAP_OFF_BEDS+3	Gas Gap Off time for bed 3
TIME_GASGAP_OFF_BEDS+4	Gas Gap Off time for bed 4
TIME_GASGAP_OFF_BEDS+5	Gas Gap Off time for bed 5
NORMAL_ENTER_STARTUP_MINNTP	Normal → Startup condition: HPST pressure lower limit
NORMAL_ENTER_STARTUP_MAXNTP	Normal → Startup condition: HPST pressure higher limit
NORMAL_ENTER_STARTUP_MNCET	Normal → Startup condition: Heatup / Desorb beds temperature limit
NORMAL_ENTER_STARTUP_MNJT_T7	Normal → Startup condition: JT temperature limit if T7 is good
NORMAL_ENTER_STARTUP_MNJT_T30	Normal → Startup condition: JT temperature limit if T7 is bad
RATE_BED_POWER_ADJUST	Bed heaters power readjustment frequency (number of sensors set between two power adjustment)
PID_SETPOINT_T5	PID set point is T5 is good
PID_SETPOINT_T6	PID setpoint is T5 is bad
PID_P	PID P parameter
PID_I	PID I parameter
PID_D	PID D parameter
PID_RATE	PID rate
PID_UPPER_LIMIT	Max voltage to apply on LR3 heater H31 or H32
PID_LOWER_LIMIT	Min voltage to apply on LR3 heater H31 or H32
PID_TEMPERATURE_LIMIT_T5	PID will be stopped if T5 is good and higher than this limit
PID_TEMPERATURE_LIMIT_T6	PID will be stopped If T5 is bad and T6 is higher than this limit
OPEN_LOOP_R1	R1 value from the open loop algorithm. See The OPEN LOOP algorithm
OPEN_LOOP_N	Number of previous Q_LFI value to average from open loop See The OPEN LOOP algorithm

Table 8-20. Lookup table parameters used in Normal state

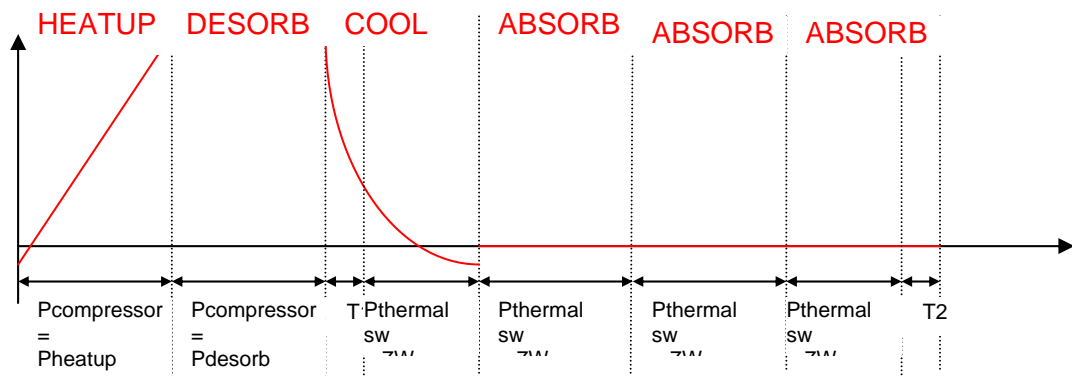

Figure 8-23: bed cycle in Normal

Beds powers

- heatup bed is powerized at “[POWER_HEATUP_BEDS](#)” watts. Each bed have its own heatup power. Heatup bed gas gap is switched off.
- Desorb bed is powerized at “[POWER_DESORB_BEDS](#)” watts. Each bed have its own desorb power. Desorb bed gas gap is switched off.
- Cooldown and Absorb beds are not powerized.
- Cooldown bed gas gap is switched on “[TIME_GASGAP_ON_BEDS](#)” seconds after the beginning of the cycle: See T1 on Figure 8-23.
- Last Absorb bed gas gap is switched off “[TIME_GASGAP_OFF_BEDS](#)” seconds before the end of the cycle: See T2 on Figure 8-23.
- Bed powers can be updated every time during the cycle.
- Bed Power are readjusted every “[RATE_BED_POWER_ADJUST](#)” ‘all sensors acquisition’ (all sensors acquisition is more or less one second). The readjustment is needed to compensate loss in 28 volts when power is applied. From example, if ‘[RATE_BED_POWER_ADJUST](#)’ is equal to 3, bed powers will be applied every 3 * time to acquire all sensors set.

Low Pressure Stabilization Bed power:

- LPSB sustain heater H7 is powerized at “[POWER_LPSB](#)”.
- LPSB power can be updated every time during the cycle.
- LPSB power is readjusted every ‘all sensors acquisition’
- FDIR : if H7 is bad, use H8 and cycle it at % of cycle time (lookup table : [NORMAL_H8_RATE_IF_H7_BAD](#)) to provide the proper power. That means H8 will be switched on from start of cycle during “[NORMAL_H8_RATE_IF_H7_BAD](#)” % of the cycle then switched off until the end of the cycle.

Cycle Time

Transition from one cycle to the next one is given by a cycle time defined on the lookup table parameter: “[TIME_CYCLE_NORMAL](#)”.

Cycle time can be updated from a lookup table patch during cycle. New cycle time is taken into account immediately. Several cases can be described, ‘time’ is the duration between start of cycle and lookup table patch

- ‘time’ < new cycle time: current cycle will continue during ‘new cycle time’ – ‘time’
- ‘time’ > new cycle time: transition to next cycle immediately.

Gas Gaps activation and desactivation delays can be updated from a lookup table patch during cycle. New delays are taken into account immediately, so gas gaps states may also be switched on or off.



FDIR

Continuously, the following triggers are checked to detect exit. The normal state will be terminated and return to startup if one of the trigger is set:

- Autonomous return to startup is enabled: set in lookup table “LU=SW_AUTO_FUNCTIONS” “Auto go to startup“
- Heatup temperature or Desorb temperature is higher than a limit defined in lookup table: “NORMAL_ENTER_STARTUP_MNCET”
- HPST pressure is lower than a limit defined in lookup table: “NORMAL_ENTER_STARTUP_MINNTP”
- HPST pressure is higher than a limit defined in lookup table: “NORMAL_ENTER_STARTUP_MAXNTP”
- JT temperature is higher than a limit defined in lookup table “NORMAL_ENTER_STARTUP_MNJT_T7” if T7 is good or “NORMAL_ENTER_STARTUP_MNJT_T30” if T7 is bad.

PID and Open Loop

The objective is to regulates LR3 temperature T5 (or T6) to a defined setpoint defined in lookup table. This functionality is only used in normal mode.

A PID regulation on LR3 heater H31 or H32 if H31 is bad can be enabled or disabled with the lookup table parameter: “LU=SW_AUTO_FUNCTIONS” “SW_AUTO_FUNCTIONS_PID”. See 8.5.3. The following parameters are stored in lookup table an can be updated:

- Set point: “PID_SETPOINT_T5” if T5 is good or “PID_SETPOINT_T6” if T5 is bad.
- P, I and D parameters: “PID_P”, “PID_I”, “PID_D”
- Pid rate (refresh delay): “PID_RATE”
- Lower and higher voltage applied to heater H31 or H32: “PID_LOWER_LIMIT” “PID_UPPER_LIMIT”
- Higher temperature (PID is switched off and parameters are reinitialized) if T5/T6 temperature is higher than this limit: “PID_TEMPERATURE_LIMIT_T5” or “PID_TEMPERATURE_LIMIT_T6”

An “Open Loop” regulation on LR3 heater H31 or H32 if H31 is bad can be enabled or disabled with the lookup table parameter:

“LU=SW_AUTO_FUNCTIONS”
“SW_AUTO_FUNCTIONS_OPEN_LOOP”

. See 8.5.48.5.4. The following parameters are stored in lookup table an can be updated:

- Set point: see PID (same parameter)
- Rate: see PID (same parameter)
- Lower and higher voltage: see PID (same parameter)
- Higher temperature: see PID (same parameter)
- Open Loop specific: R1 and N.
-

PID and OPEN LOOP can run alone or together.

Normal-Mode only

A bed can be flagged as ‘normal-mode only’ with the telecommand TC(8, 4) “set bed state”. If a bed is set to ‘normal-mode only’:

- It will be removed when transition from normal to startup (on → off).
- It will be inserted when transition from startup to normal (off → on).



8.3.27. SHUTDOWN Mode Description

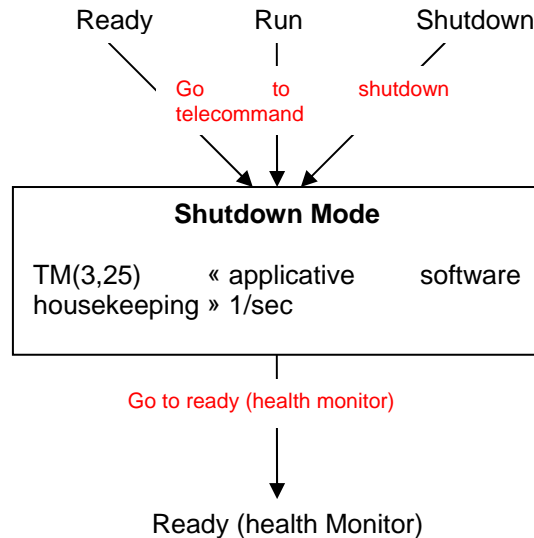

Figure 8-24: Shutdown mode transitions

The shutdown mode is reached by the “go to shutdown” telecommand from ready, run or shutdown modes. This mode can also be reached automatically when one of the following conditions is true:

- both ADC reading chains are bad.
- JT heaters H34 or H35 is always ON (detection in run mode only).
- Electronics temperature reached the second level limit (detection in run mode only).

Note: in all cases, the “switch off” event is also sent to CDMS.

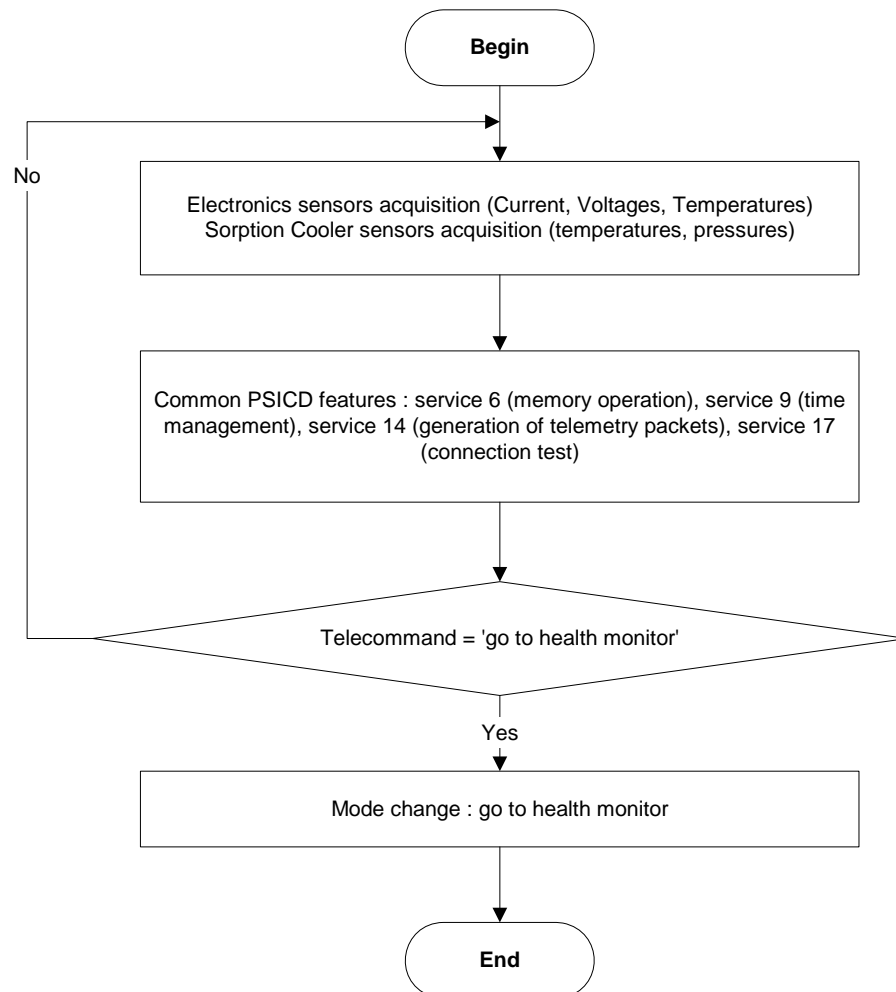

Figure 8-25: Shutdown mode main features

8.3.28. Set Initial Bed Position telecommand

This telecommand can be launched in init, ready or shutdown modes. It is used to select which bed will start in 'Heatup' state in startup. This telecommand requires one argument: position of heatup bed from 0 to 5.

Examples:

- "Set Initial Bed Position" with an argument equal to 0 will lead to the configuration : Bed 0 = heatup, Bed 1 = desorb, bed 2 = cooldown, bed 3 = bed 4 = bed 5 = absorb
- "Set Initial Bed Position" with an argument equal to 3 will lead to the configuration: Bed 4 = heatup, bed 5 = desorb, bed 0 = cooldown, bed 1 = bed 2 = bed 3 = absorb.

8.3.29. Return to Initial Bed State telecommand

This telecommand can be launched in init, ready or shutdown modes. It is used to initialize bed positions. After reception of this telecommand, beds states will be: bed 0 = heatup, bed 1 = desorb, bed 2 = cooldown, bed 3 = bed 4 = bed 5 = absorb.

8.3.30. Set Bed State telecommand

This telecommand can be launched in init, ready, run and shutdown modes. It is used to set a bed in a defined state. This telecommand requires one argument that contains two information:



the bed number from 0 to 5 and the desired state: 'good', 'bad' and 'normal only' (see end of 8.3.26). If this telecommand is launched in run mode, its effect will be taken into account immediately. For other modes, its effect will be taken into account as soon as Startup state is launched. The telecommand will be rejected if two beds are already off.

The following table shows the actions performed by the software when telecommand is launched in run mode.

Telecommand ↓↓↓	Bed state before TC		
	Good	Bad	Normal only
Set bed state to good (clear 'normal only' flag)	Do nothing	Reinsert bed	Add bed if mode is startup or defrost. Do nothing if mode is normal
Set bed state to bad (clear 'normal only' flag)	Remove bed immediately	Do nothing	Do nothing if mode is startup or defrost. Remove bed if mode is normal
Set bed state to normal only (set 'normal only' flag)	Remove bed if mode is startup or defrost. Do nothing if mode is normal	Do nothing if state is startup or defrost. Add bed If state is normal	Do nothing

Table 8-21. Set Bed State action in run mode

8.3.31. Set Device State telecommand

This telecommand can be launched in init, ready, run and shutdown mode. It is used to set the device status: 'good' or 'bad'. This telecommand requires one argument that contains two information: the device id and the state 'good' or 'bad' to apply on the device. A device can be:

- An Analog Digital Converter (ADC)
- A Heater
- A Sorption Cooler temperature sensor
- A Sorption Cooler pressure sensor

Device id list is described in *Chapter 10 (TC(8,4): "Perform Activity of Function")*

Telecommand	Action
set H1 to H6 → bad	If SW_AUTO_FUNCTIONS_DETECT_BAD_HTR active: a bed will be removed. If SW_AUTO_FUNCTIONS_DETECT_BAD_HTR inactive: Heater will be switched off but bed will stay on
set H1 to H6 → good	Bad bed will not be reinserted in cycle automatically : the "add bed " telecommand must be launched.
set H11 to H16 → bad	see "H1 to H6 → bad"
set H11 to H16 → good	See "set H1 to H6 → good"
set H21 to H26 → bad	See "H1 to H6 → bad"
set H21 to H26 → good	See "set H1 to H6 → good"
set H8 → bad	If SW_AUTO_FUNCTIONS_DETECT_BAD_HTR active: autonomous bad H8 detection will be used and H8 may be switched on if procedure find that H8 is good else, procedure will jump to ready mode. See Chapter 7. If SW_AUTO_FUNCTIONS_DETECT_BAD_HTR inactive: H7 will be used instead of H8
set H8 → good	If SW_AUTO_FUNCTIONS_DETECT_BAD_HTR active: same as "set H8 → bad" If SW_AUTO_FUNCTIONS_DETECT_BAD_HTR inactive: H8 will be used instead of H7
set H7 → bad	If SW_AUTO_FUNCTIONS_DETECT_BAD_HTR active: autonomous bad H7



	detection will be used and H7 may be switched on if procedure find that H7 is good else, procedure will launch H8 instead of H7. See Chapter 7. If SW_AUTO_FUNCTIONS_DETECT_BAD_HTR inactive: H7 will be used instead of H8. See Chapter 7
set H7 → good	If SW_AUTO_FUNCTIONS_DETECT_BAD_HTR active: same as “set H7 → bad” If SW_AUTO_FUNCTIONS_DETECT_BAD_HTR inactive: H7 will be used instead of H8
set H31 or H32 → bad	In all cases see action described in Chapter 7 and AD8@ 6.2.3 id#4
set H31 or H32 → good	In all cases see action described in Chapter 7 and AD8@ 6.2.3 id#4
set H34 or H35 → bad	In all cases (SW_AUTO_FUNCTIONS_DETECT_BAD_HTR active or inactive) H3x will be set to bad and stay to bad until telecommand “set H34 or H35 → good”. If H34 is set to bad, H35 will be used in defrost. If H34 and H35 set to bad, defrost will not use H34 and H35. If H34 is good and H35 bad, H34 will be used for defrost. Autonomous H34 / H35 failure detection will not put H34 / H35 to good.
set H34 or H35 → good	If SW_AUTO_FUNCTIONS_DETECT_BAD_HTR active: H34 or H35 will be set to good if autonomous failure detection do not detect that heater is bad. If SW_AUTO_FUNCTIONS_DETECT_BAD_HTR inactive: H34 or H35 will be set to good.
set H33 or H36 → bad	Same as set H34 or H35 → bad
set H33 or H36 → good	Same as set H34 or H35 → good

Table 8-22

Lookup table parameter	Use
SW_AUTO_FUNCTIONS_DETECT_BAD_HTR	Autonomous Function enable / Disable : bad heater detection.

Table 8-23

8.3.32. Sensors acquisition

The following lookup table parameters are used for sensors management:

Lookup table parameter	Use
SENSORS_MEAN_T... SENSORS_MEAN_T+28	Sorption Cooler temperature sensors acquisition number for average
SENSORS_MEAN_P... SENSORS_MEAN_P+7	Sorption Cooler pressure sensors acquisition number for average
SENSORS_MEAN_TEST	Electronics tests sensors acquisition number for average
SENSORS_TRESEHOLD	Sorption Cooler sensors tresehold for software averaged sensors

Table 8-24. Lookup table parameters for sensors

For all modes, a list of sensors is defined and acquired continuously.

Mode	Used sensors
Init	Electronics sensors: voltages, intensity, electronics temperature
Ready	Electronics + Sorption Cooler sensors (temperature, pressures)
Run	Electronics + Sorption Cooler sensors
Shutdown	Electronics + Sorption Cooler sensors

Table 8-25. Sensors list

For example, for the list: {T1, T2, T3, P1, P2, P3}, the sensors will be read:



T1 → T2 → T3 → P1 → P2 → P3 → T1 → T2

↑
 All sensors set readed

Sensors average: several sensors are not averaged, other are averages by hardware, other by software. For averaged sensors, the number of averages can be set in lookup table. For software averaged sensors only, a tresehold can be set in lookup table: “SENSORS_TRESEHOLD”.

Averaged type	Sensors list	Lookup table parameters
Not averaged	Electronics sensors	None
Hardware average	T1 to T18 T26 to T30	“SENSORS_MEAN_T” to “SENSORS_MEAN_T+17” “SENSOR_MEAN_T+24” to “SENSOR_MEAN_T+28”
Software average	T20 to T25 P1 to P8	“SENSORS_MEAN_T+18” to “SENSORS_MEAN_T+23” “SENSORS_MEAN_P” to “SENSORS_MEAN_P+7”

Table 8-26. Sensors average parameters in lookup table

For hardware averaged sensors, sensor is read “SENSOR_MEAN_x_x” (lookup table value) times and an average is performed on the overall reads.

For software averaged sensors, sensor is read “SENSOR_MEAN_x_x” times but the first values below “SENSORS_TRESEHOLD” are not taken into account for average calculation.

When reading a sensors list, all sensors in the list will be read sequentially. If a sensor within the list requires an average, the whole needed readouts are done before to switch to the next sensor.

Note: for an average value of 30 for all sensors, about 1 second is required to read all sensor set in ready or run mode.

8.3.33. EEPROM configuration

Two EEPROMS (each of 256 kwords of 32 bits) are accessible. The first one (called EEPROM 1) contains:

- The initial version of the applicative software
- The initial version of the lookup table
- 1024 checksums (each checksum is relative to a 256 words block of the eeprom 1)

The second one (called EEPROM N) contains:

- The last (or patched) version of the applicative software
- The last version of the lookup table
- 1024 checksums (each checksum is relative to a 256 words block of the eeprom N)
- The address of the lookup table to load

IMPORTANT

For SCS-R unit has been reported an error in EEPROM#1. This EEPROM section should not be used for any SCS memory operations. However, since no OBSW or data is stored in such memory area this has no impact on functionality of SCS-R.



The maximum size of memory load commands allowed is 50 SAUs. Bigger size uploads lead to failure of SCS to accept command and eventual switch-off of SCS by OBCP from 1553 FDIR on TFh TC = SCS RT "SICK TC".

TC memory upload rate of 1 Hz (one TC per second) is ok.

EEPROM « version 1 » (address from 0x80000000 to

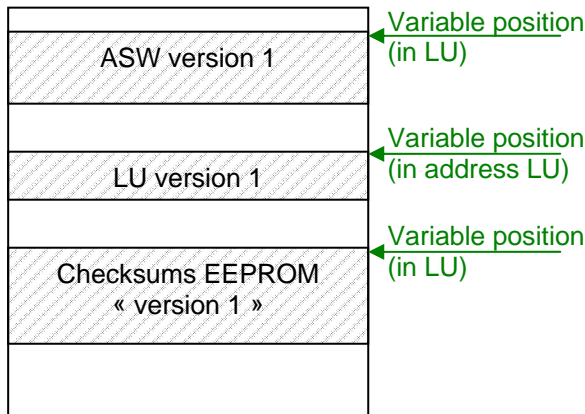

EEPROM version 1 contains initial versions of:

- Applicative software (ASW version 1)
- lookup table (LU version 1)
- Checksums (Checksums EEPROM 1)

EEPROM « version n » (address from 0x80040000 to 0x8007FFFF)

EEPROM version n contains loaded (patched) versions of:

- Applicative software (ASW version n)
- lookup table (LU) (LU version n)
- Checksums (checksums EEPROM N)
- The current position of the lookup table to load.(Address LU).

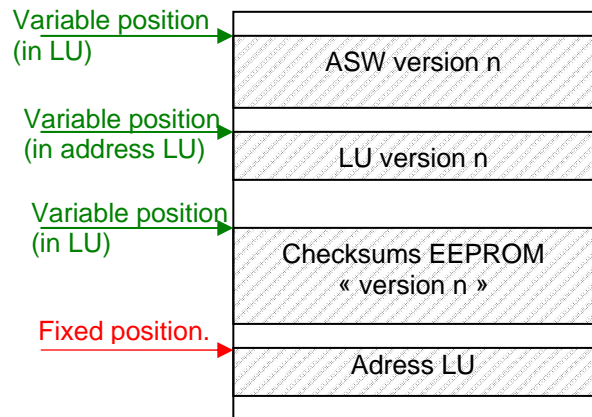

Figure 8-26: Eeprom configuration

Field	Usage	Position
Address LU	Contains the base address of the lookup table to load and use	<p>Fixed in Eeprom N</p> <p>It is composed of three 32-bits values</p> <ul style="list-style-type: none"> - One at 0x8007ffa - One at 0x8007ffc - One at 0x8007ffe <ul style="list-style-type: none"> - If the three values are equal, lookup table base address is equal to value - If two values are equal, lookup table base address is equal to value - If every values are different or bad content, bad eeprom ... the lookup table base



		address is equal to 0x80000000
LU Version 1	Initial version of the lookup table. Its values shall never be updated (nevertheless it is possible to do it)	'Address LU' links to LU version 1. The position can be updated (by updating value at 'Address LU')
LU Version n	Patched version of the lookup table.	'Address LU' links to LU version N. The position can be updated (by updating value at 'Address LU')
ASW Version 1	Application software version 1. It shall never be updated (nevertheless it is possible to do it).	Contained in the lookup table, the position can be updated. Lookup table version 1 shall links to application software 1. Lookup table version n can link to application software version 1 or version n. 'ASW version 1' base address contains the size of the applicative software 1. 'ASW version 1' base address + 1 contains the checksum of the applicative software 1. 'ASW version 1' base address +2.... Contains the applicative software 1
ASW Version n	Application software version n.	Contained in the lookup table, the position can be updated. Lookup table version 1 shall links to application software 1. Lookup table version n can link to application software version 1 or version n. 'ASW version n' base address contains the size of the applicative software n. 'ASW version n' base address + 1 contains the checksum of the applicative software n. 'ASW version n' base address +2.... Contains the applicative software n.
Checksum Eeprom 1	Checksums of the EEPROM 1.	Each lookup table contains the two checksum position (checksum 1 and checksum n). It can be updated.
Checksum Eeprom n	Checksums of the EEPROM N.	Each lookup table contains the two checksum position (checksum 1 and checksum n). It can be updated

- ▶ In order to switch from "Lookup Table Version 1" to "Lookup Table Version n" or the reverse, set the right lookup table base address to EEPROM at "Address LU" (0x8007ffa, 0x8007ffc and 0x8007ffe)
- ▶ In order to switch from "Applicative Software Version 1" to "Applicative Software Version n" or the reverse, set the right applicative software base address on the lookup table field (LU = SW_ASW_ADR)



8.3.34. Lookup table

In this paragraph the Lookup table is described (see Appendix 1). The lookup table is selected by writing its base address in 'Address LU'. See EEPROM configuration.

The loading of the lookup table via TC(6,2) is performed following this table:

TC(6,2) application data word 0	SW_AUTO_FUNCTION MSB
TC(6,2) application data word 1	SW_AUTO_FUNCTION LSB
TC(6,2) application data word 2	SW_ASW_ADR MSB
TC(6,2) application data word 3	SW_ASW_ADR LSB
Etc...	Etc...

Autonomous functions bits / FDIR actions

The first word of the lookup table contains flags that enable or disable autonomous function. Several of them are related to the FDIR actions. The table below shows the correspondence between lookup table flag and FDIR action. Example: if Bit 6 is set, the FDIR action "Reading chains failure 6.2.1 id# 1" will be autonomously performed.

- Bit 3 = SW_AUTO_FUNCTIONS_DIAG_RUN_COOLER
- Bit 4 = SW_AUTO_FUNCTIONS_DIAG_RUN_ELEC
- Bit 5 = SW_AUTO_FUNCTIONS_DETECT_BAD_HTR
- Bit 6 = SW_AUTO_FUNCTIONS_DETECT_BAD_ADC
- Bit 7 = SW_AUTO_FUNCTIONS_DETECT_BAD_SENSOR
- Bit 8 = SW_AUTO_FUNCTIONS_GOTO_STARTUP
- Bit 9 = SW_AUTO_FUNCTIONS_GOTO_DEFROST
- Bit 10 = SW_AUTO_FUNCTIONS_GOTO_OFFNORMAL

	Bit 3	Bit 4	Bit 5	Bit 6	Bit 7	Bit 8	Bit 9	Bit 10
Sensors failure 7.3.1.1.4 id# 1								
Sensors failure 7.3.1.1.4 id# 1								
Sensors failure 7.3.1.1.4 id# 2								
Sensors failure 7.3.1.1.4 id# 3								
Sensors failure 7.3.1.1.4 id# 4								
Sensors failure 7.3.1.1.4 id# 5	always enabled: just failure reported to telemetry							
Sensors failure 7.3.1.1.4 id# 6	always enabled: just failure reported to telemetry							
Sensors failure 7.3.1.1.4 id# 7	always enabled: use redundant if bad nominal else just report failure to tm							
Sensors failure 7.3.1.1.4 id# 8								
Sensors failure 7.3.1.1.4 id# 9	always enabled: use redundant if bad nominal else just report failure to tm							
Sensors failure 7.3.1.1.4 id# 10								
Heaters failures 7.3.1.1.7 id# 1								
Heaters failures 7.3.1.1.7 id# 2								
Heaters failures 7.3.1.1.7 id# 3								
Heaters failures 7.3.1.1.7 id# 4								
Heaters failures 7.3.1.1.7 id# 5								
Heaters failures 7.3.1.1.7 id# 6	No detection is performed							
Critical Parts Failure 7.3.1.1.9 id# 1	always enabled							
Critical Parts Failure 7.3.1.1.9 id# 2	always enabled							
Critical Parts Failure 7.3.1.1.9 id# 3	Must launch "hardware test" telecommand to detect failure							
Critical Parts Failure 7.3.1.1.9 id# 4	must launch "hardware test" telecommand to detect 1553 failure. Wrong TC detection: always enabled.							
Critical Parts Failure 7.3.1.1.9 id# 5								
Power Failures 7.3.1.1.10 id# 1								
Power Failures 7.3.1.1.10 id# 2								
Actions For Safety 7.3.1.1.11 id# 1								
Actions For Safety 7.3.1.1.11 id# 2								
Actions For Safety 7.3.1.1.11 id# 3								
Operational Actions 7.3.1.1.12 id# 1								
Operational Actions 7.3.1.1.12 id# 2								



Operational Actions 7.3.1.1.12 id# 3							
External FDIR 7.3.1.1.13 id# 1						always enabled	
External FDIR 7.3.1.1.13 id# 2						always enabled	
External FDIR 7.3.1.1.13 id# 3						always enabled	
External FDIR 7.3.1.1.13 id# 4						always enabled	
External FDIR 7.3.1.1.13 id# 5						always enabled	
External FDIR 7.3.1.1.13 id# 6						always enabled	

Table 8-27. Correspondence lookup table flags and FDIR actions

When parameters are taken into account?

All lookup table parameters are taken into account immediately (as soon as the lookup table is loaded) except for the following parameters:

- Hardware tests: SW_TEST_EXT_TIMER_LENGTH,
- SW_TEST_FPGA_TIMER_LENGTH: if 'external timers' or 'fpga timer' test is launched, the previous parameter value is used until the end of the test.
- Health check: HEALTHCHECK_TIME_LIMIT, HEALTHCHECK_TIME_LIMIT_COLD, HEALTHCHECK_MAX_POWER, HEALTHCHECK_MIN_POWER: if a health check step is currently running, these parameters will be taken on the next step.
- Regeneration: REGENERATION_POWER, REGENERATION_TIME,
- REGENERATION_MAX_TIME: if a regeneration step is currently running, these parameters will be taken on the next step.
- Startup: STARTUP_EXIT_DEFROST_TIME: if the defrost process is currently running, the previous parameter value will be used until the end of the defrost procedure.
- Faults: FAULT_ELECTRONIC_12V_TIME: a time out is launched when a bad 12 volts is detected. Must wait the end of this time out or that the 12 volts becomes good again, to take into account the newest value.
- PID_RATE: The new sampling rate value will start after the current sample acquisition.

Lookup Table Content Check

Several Lookup Table parameters are checked by the on-board software in order to prevent internal errors (such as division by 0). The table below shows the checked lookup table parameters, their available range and the default value if TC(6,2) intends to load wrong value.

Parameter	Correct range	Default Value	Note
SW_ASW_ADR	0x80000000 to 0x8007ffff	0x80002000	
SW_CHECKSUM_1_ADR	0x80000000 to 0x8003ffff	0x80001000	
SW_CHECKSUM_N_ADR	0x80040000 to 0x8007ffff	0x80005000	
HW_CAL_ADC_V12	≠ 0	3276.75	
HW_CAL_ADC_V28	≠ 0	2184.5	
HW_CAL_ADC_V31	≠ 0	1310.7	
HW_HEATERS_RBL (6 values)	> 0	5.42	
HW_HEATERS_RV	> 0	5.3	
HW_HEATERS_RH7	> 0	15	
HW_HEATERS_RH31	> 0	144	
HW_HEATERS_RH32	> 0	144	
OPEN_LOOP_R1	≠ 0	1.55	
OPEN_LOOP_N	≠ 0	10000	
SENSORS_MEAN_xxx (41 values)	< 0x7f	0x7f	
SENSORS_TRESEHOLD			A lookup table failure is returned if threshold >= SENSORS_MEAN_T20..T25 SENSORS_MEAN_P1..P6

Table 8-28

8.3.35. FDIR

In this paragraph, the FDIR errors and recovery actions from the point of view of the ASW are described. For a more general description of FDIR check Chapter 7.



8.3.35.1. FDIR: Reading Chains Failure (ASW only)

If the first ADC chain is right, it is used; else the second ADC chain is used. If both ADC chains are wrong, a request for shutdown is launched.

Two errors type can happen:

- ADC is busy: the sensor data acquisition time is too long (upper than 1sec). The “ADC nominal busy” or “ADC redundant busy” is set in the housekeeping word “Fault status OBSW”.
- ADC is out of range: first VGAIN electronics sensor is compared to value \pm delta. If sensor is outside the range, the “ADC nominal out of range” or “ADC redundant out of range” is set in the housekeeping word “Fault status OBSW”.

Lookup table parameter	Use
FAULT_ELECTRONIC_ADC_REF	Digital output from reference sensor shall be compared to this value +- delta
FAULT_ELECTRONIC_ADC_DELTA	Digital output from reference sensor shall be compared to reference value +- this parameter

8.3.35.2. FDIR: Sensors Failures (ASW only)

See AD8 for triggers and scenarios.

Bad sensor detection can not be performed automatically. This section describes only the scenarios that happen when a sensor is set to bad from the telecommand “set device state”.

All sensors

Sensors state can be seen in telemetry “device status” word.

Bed PRT specific

Lookup table parameter	Use
FAULT_COND_PRT_TEMPERATURE_DEFAULT	Default temp. for all PRTs sensors in case of failure

Cold end temperature specific

Lookup table parameter	Use
FAULT_COND_JT_TEMPERATURE_DEFAULT	Default temp. for JT sensors in case of failure

8.3.35.3. FDIR: Heaters Failures (ASW only)

Gas Gap heaters

If gas gap on and current lower than a limit, then gas gap heater is set to bad.

If gas gap off and current upper than a limit, then gas gap heater is set to bad.

Lookup table parameter	Use
FAULT_HEATERS_H2I_ON	Gas Gaps current must be higher than this limit when active
FAULT_HEATERS_H2I_OFF	Gas Gap current must be lower than this limit when inactive

Multiple voting is performed for this failure detection.

LPSB startup heater H8 always ON

If T17 and T18 are both up a limit or

T17 or T18 is bad and the other is up a limit then LPSB heater H8 is set to bad.



Lookup table parameter	Use
FAULT_HEATERS_H8	If T17 and T18 temperature are above this limit, H8 is always on (Failure from FDIR)

LPSB sustain heater H7 always ON or OFF

The software calculates I_{measured} from sensors values and compare it to applied from dac value applied to heater. If $|I_{\text{measured}} - I_{\text{applied}}| > \text{limit}$, then the heater is set to bad.

Lookup table parameter	Use
FAULT_HEATERS_H7	I_{measured} on H7 must be equal to I_{applied} (from DAC value) \pm this parameter
HW_CAL_GAIN_H7	GAINh7 part of $I_{h7} = \text{GAINh7} + \text{OFFSETh7}$
HW_CAL_OFFSET_H7	OFFSETh7 part of $I_{h7} = \text{GAINh7} + \text{OFFSETh7}$
HW_HEATERS_RH7	H7 resistor for LPSB power H7 calculation
HW_CAL_ADC_V12	Calibration ADC to volts for 12 volts

Multiple voting is performed for this failure detection.

Cold end heaters always ON or OFF

The software calculated I_{measured} from sensors values and compare it to applied from dac value applied to heater. If $|I_{\text{measured}} - I_{\text{applied}}| > \text{limit}$, then the heater is set to bad.

Lookup table parameter	Use
FAULT_HEATERS_H31	I_{measured} on H31/H32 must be equal to I_{applied} (from DAC value) \pm this parameter
HW_CAL_GAIN_H31	GAINh31 part of $I_{h31} = \text{GAINh31} + \text{OFFSETh31}$
HW_CAL_OFFSET_H31	OFFSETh31 part of $I_{h31} = \text{GAINh31} + \text{OFFSETh31}$
HW_CAL_GAIN_H32	GAINh32 part of $I_{h32} = \text{GAINh32} + \text{OFFSETh32}$
HW_CAL_OFFSET_H32	OFFSETh32 part of $I_{h32} = \text{GAINh32} + \text{OFFSETh32}$
HW_HEATERS_RH31	H31 resistor for LR3 (nominal) power calculation
HW_HEATERS_RH32	H32 resistor for LR3 (redundant) power calculation
HW_CAL_ADC_V31	Calibration ADC to volts for 31 volts

Multiple voting is performed for this failure detection.

JT heaters H34 H35 always ON or OFF

If mode \neq defrost and T7 or T30 (if T7 is bad) is up a limit then H34 or H35 (if H34 is already bad) is set to bad. It is always on \rightarrow request shutdown to CDMS.

If mode = defrost and T7 or T30 (if T7 is bad) has not increased enough within a certain amount of time, the heater H34 or H35 (if H34 is already bad) is set to bad. It is always off.

Lookup table parameter	Use
FAULT_HEATERS_H34_H35_T_UP_T7	H34/H35 bad if JT temperature up this limit (using T7)
FAULT_HEATERS_H34_H35_T_UP_T30	H34/H35 bad if JT temperature up this limit (using T30)
FAULT_HEATERS_H34_H35_DELTA_T	H34/H35 bad if this value is not reached within 'rise time'
FAULT_HEATERS_H34_H35_RISE_TIME	H34/H35 bad if 'delta T' is not reached within this time value



8.3.35.4. *FDIR: Critical Parts Failures*

AD8 describes all FDIR triggers and scenarios

Processor Failure (Watchdog).

Watchdog prevents software stuck. 2 levels of watdog are defined:

- First level: if software is stuck between 63,9 and 64 ms an error “Watchdog First Level” will be reported on “Fault Status OBSW” from housekeeping packet and the software continue its execution. Between two housekeepings telemetries, several “Watchdog first level” can happen. The housekeeping will report that one or several errors happened between the two housekeeping telemetries.
- Second level: if software is stuck for more than 64ms, a reset is performed and software restarts in boot mode. If software was restarted from this second level, the error “Watchdog second level” will be reported on the next start of boot software (following the reset) on the first TM(3,25) only.

FPGA failure (ASW ONLY)

The housekeeping flag “Fault Status FPGA” from “Fault Status SCE” word is set when ADC is busy and a bad FPGA state was found on its registers.

Memory failure

Memory failures are detected following a memory test operation (launched by telecommand).

1553 failure

1553 failure can be reported during the execution of the boot or applicative software.

Over temperature of electronics (ASW ONLY)

Two limits are defined in lookup table

Lookup table parameter	Use
FAULT_ELECTRONIC_TEMP_FIRST	Electronics temperature first limit
FAULT_ELECTRONIC_TEMP_SECOND	Electronics temperature second limit

There are three electronics temperature sensors. Electronics temperature is equal to the maximal value of the three sensors.

- If electronics temperature first limit < electronics temperature < electronics temperature second limit: the flag “Electronics Over Temperature limit 1” from “Fault Status OBSW” is set.
- If electronics temperature > electronics temperature second limit: the flag “Electronics Over Temperature limit 2” is set and a request for shutdown is sent to the CDMS.

8.3.35.5. *FDIR: Power Failures (ASW only)*

12 Volts Failure

See description in Chapter 7.

Failure is enunciated to “12 Volts Error” bit of housekeeping word: “Fault Status OBSW”

Lookup table parameter	Use
FAULT_ELECTRONIC_12V_UP_LIMIT	If 12 volts is greater than this value, 12 volts is wrong
FAULT_ELECTRONIC_12V_LOW_LIMIT	If 12 volts is lower than this value, 12 volts is wrong
FAULT_ELECTRONIC_12V_TIME	Error is not taken into account before this time value.

28 Volts Failure

See description on AD8.



Failure is enunciated to “28 Volts Error” bit of housekeeping word: “Fault Status OBSW”

Lookup table parameter	Use
FAULT_ELECTRONIC_28V_DEFAULT	If 28 volts is wrong use this value to calculate the power
FAULT_ELECTRONIC_28V_UP_LIMIT	If 28 volts is greater than this value, 28 volts is wrong
FAULT_ELECTRONIC_28V_LOW_LIMIT	If 28 volts is lower than this value, 28 volts is wrong

8.3.35.6. FDIR: Actions for Safety (ASW only)

See description on Chapter 7.

Failure is enunciated to “Bed Over Temperature”, “Bed Over Pressure” or “LPSB Over Temperature” bit of housekeeping word “Fault Status SCE”.

Lookup table parameter	Use
FAULT_COND_BED_TEMPERATURE_LIMIT	Failure if bed temperature greater than this limit
FAULT_COND_BED_PRESSURE_LIMIT	Failure if bed pressure greater than this limit
FAULT_COND_LPSB_TEMPERATURE_LIMIT	Failure if LPSB temperature greater than this limit

8.3.35.7. FDIR: Operational actions (ASW only)

Bad Bed Detection

Bad bed detection is described in The BAD BED DETECTION algorithm.

The following lookup table parameters are needed by the bad bed detection procedure:

Lookup table parameter	Use
BAD_BED_DETECT_COOL_TEMP_LIMIT	Cooldown bed temperature limit
BAD_BED_DETECT_COOL_PRESSURE_LIMIT	Cooldown bed pressure limit
BAD_BED_DETECT_HEATUP_TEMP_LIMIT	Heatup bed temperature limit
BAD_BED_DETECT_HEATUP_PRESSURE_LIMIT	Heatup bed pressure limit
BAD_BED_DETECT_CYCLE_PERIOD	Cycle period limit to launch or not bad bed detection

It can be activated or deactivated with the lookup table parameter: “[SW_AUTO_FUNCTIONS](#)” “Autonomous go to off-normal”.

Bad bed detection is used in run mode. It is launched:

- At the end of each cycles except for the first one
- If cycle time is higher than a limit defined in lookup table
- “[BAD_BED_DETECT_CYCLE_PERIOD](#)”

Other operational actions

Other operational actions are described in Chapter 7 (RUN Mode section).

8.4. Bed temperature calculation

Bed temperature is often used within software procedure. Bed temperature is not equal to a single sensor value (as T20 or T15...) but is equal to a calculation defined below.

Bed temperature is equal to the sum of the thermocouple temperature excluding highest and lowest temperature + PRT temperature applied to the bed



$T_{\text{thermocouple}} = \frac{1}{4} * [T_{20} + T_{21} + T_{22} + T_{23} + T_{24} + T_{25} - \text{Max}(T_{20}, T_{21}, T_{22}, T_{23}, T_{24}, T_{25}) - \text{Min}(T_{20}, T_{21}, T_{22}, T_{23}, T_{24}, T_{25})]$

Temperature bed 1 = $T_{15} + T_{\text{thermocouple}}$
Temperature bed 2 = $T_{16} + T_{\text{thermocouple}}$
Temperature bed 3 = $T_{26} + T_{\text{thermocouple}}$
Temperature bed 4 = $T_{27} + T_{\text{thermocouple}}$
Temperature bed 5 = $T_{28} + T_{\text{thermocouple}}$
Temperature bed 6 = $T_{29} + T_{\text{thermocouple}}$

Note: $T_{\text{thermocouple}}$ is the same value for all beds for a defined time.



8.5. ASW processes description

8.5.1. The Health Check procedure

8.5.1.1. OBJECTIVE

The purpose of the health check procedure is to check the status of the Planck Sorption Cooler System both in flight and on the ground. The check consist in verifying that all the heater circuits (CE, LPSB, JT etc) are functioning properly (current goes through the heater circuit and, if possible, the respective temperature or pressure is changed as expected). The health check procedure will perform all the verifications on the heating circuit but will not make any system decision on its results. The ground operator, comparing those data with previous run and with proper parameter ranges will decide on the status of the system and decide on how to operate the cooler.

8.5.1.2. THE PROCEDURE

When the system enters into Ready Mode, the health monitoring process is automatically performed: it consists in the readout of all the system sensors (T and P), checking that all the values result are within the limits relative to the coolers present condition (i.e. first start or re-start).

Once the health monitoring process has confirmed the functionality of the system sensors, the health check procedure can be started by command. If one or more sensors fails the monitoring test they, will be excluded from the health check procedure: a flag will be raised and a message generated to communicate the failure in order to establish the appropriate actions. During the whole health check procedure the cooler safety limits needs to be continuously monitored in order to ensure the safety of the system.

The health check will test the Compressor Assembly and the Cold End status by performing the actions described in the following list (to be performed in sequence). The limits indicated in the processes are summarized in a dedicated uplink table (see Table 8-29): its values might be changed depending on whether the cooler is on the ground or in flight.

Sensor or parameter	Value	Range
ΔP_{LP}	50 Torr	10-800 Torr
time _{limit}	667 s	100-1000 s
T _{LP-LIMIT}	310 K	290-323 K
max power(CE)	220 W	See TMU spec.
Min power (CE)	5-10 W	0-30 W
T _{BED-LIMIT}	390 K	310-450 K
P _{BED-LIMIT}	750 psia	0-750 psia
ΔT_{COLD}	0.5 K	0.1-2 K
time _{limit-cold}	2 s	0-667 s

Table 8-29



Procedure

All sensors OK from health monitoring process? If NOT exclude the subsystem from healthcheck and inform operator.

1. LPSB

- a. Read initial low pressure sensor (LP_{INI}); Sustain heater ON (Max Power) until low pressure greater than $LP_{INI} + \Delta P_{LP}$ Low P OR time heater ON $> time_{limit}$; heater OFF
- b. Startup heater ON until T_{17} OR T_{17} greater than $T_{LP-LIMIT}$ OR time heater ON $> time_{limit}$; heater OFF

2. Compressor Elements

- a. All CE Heaters OFF, all GGA OFF
- b. CE#1 heaters ON (max power(CE)) until temperature of the bed $> T_{BED-LIMIT}$ OR pressure of the bed $> P_{BED-LIMIT}$ OR time heater ON $> time_{limit}$; heater OFF
- c. CE#1 heater ON (min power, only on variable heater circuit) until time heater ON $> time_{limit}$; heater OFF
- d. CE#1 gas gap heater ON until time heater ON $> time_{limit}$; heater OFF
- e. Repeat step a,b,c,d for each CE (2,3,4,5,6, and again 1)

3. Cold End

- a. Read initial JT temperature sensor $T_{7initial}$ and $T_{30initial}$; turn JT heater H34 ON UNTIL $T_7 > T_{7initial} + \Delta T_{COLD}$ OR $T_{30initial} + \Delta T_{COLD}$ OR time heater ON $> time_{limit-cold}$; H34 heater OFF
- b. Read initial JT temperature sensor $T_{7initial}$ and $T_{30initial}$; turn JT heater H35 ON UNTIL $T_7 > T_{7initial} + \Delta T_{COLD}$ OR $T_{30initial} + \Delta T_{COLD}$ OR time heater ON $> time_{limit-cold}$; H35 heater OFF
- c. PF heater H33 ON: time heater ON $> time_{limit-cold}$; H33 heater OFF
- d. PF heater H36 ON: time heater ON $> time_{limit-cold}$; H36 heater OFF
- e. Read initial LR3 temperature sensor $T_{5initial}$ and $T_{6initial}$; turn LR3 heater H1 ON UNTIL $T_5 > T_{5initial} + \Delta T_{COLD}$ OR $T_{6initial} + \Delta T_{COLD}$ OR time heater ON $> time_{limit-cold}$; H1 heater OFF
- f. Read initial LR3 temperature sensor $T_{5initial}$ and $T_{6initial}$; turn LR3 heater H2 ON UNTIL $T_5 > T_{5initial} + \Delta T_{COLD}$ OR $T_{6initial} + \Delta T_{COLD}$ OR time heater ON $> time_{limit-cold}$; H2 heater OFF

IMPORTANT:

HEALTHCHECK Step1, LPSB H7 Sustain Heater Test, is performed by using power value 0x48 POWER_LPSB and NOT H7 max power.



8.5.2. The Regeneration procedure

Procedure

- 1) Turn off LPSB power (if any applied) and wait until HPST Pressure < MAX_REGEN_PRESSURE.
- 2) Turn on GGA heater 2,3,4,5,6 (all GGA but the one of the CE being heated)
- 3) Turn on CE-1 heater with POWER_REGEN UNTIL Temperature CE-1 > GGA_ON_TEMPERATURE.
- 4) keep TCE at GGA_ON_TEMPERATURE (plus minus the same delta used in step 4) using bang-bang scheme with power equal to POWER_REGEN (180W) until pressure in the HPST is lower than MAX_REGEN_PRESSURE
- 5) Continue with step 2 UNTIL TCE-1 > REGEN_TEMPERATURE +10 K while CE-1 Pressure < MAX_REGEN_PRESSURE.
If CE-1 Pressure exceeds MAX_REGEN_PRESSURE turn off heater and wait that pressure goes back below MAX_REGEN_PRESSURE.
If time exceeds MAX_REGEN_TIME go to step 5.
- 6) Keep TCE-1 at REGEN_TEMPERATURE +/- 10 K for REGEN_TIME using bang-bang scheme: if TCE-1 less than REGEN_TEMPERATURE-10 K turn ON heater, if T > REGEN_TEMPERATURE+10 K turn off heater.
- 7) Turn CE-1 Heater OFF and wait until TCE-1 less than GGA_ON_TEMPERATURE
- 8) Turn ON GGA-1, turn OFF GGA-2
- 8) Repeat step 3-7 for the CE-2, CE-3, CE-4, CE-5, CE-6 (with the corresponding GGA)

Lookup table parameters are:

POWER_REGEN	CE heater power to run the regeneration procedure
REGEN_TEMPERATURE	Temperature to be maintained for the regeneration process
MAX_REGEN_PRESSURE	Maximum pressure in the HPST not to be exceeded during the regeneration process
REGEN_TIME	Time needed to maintain the CE at REGEN_TEMPERATURE to complete the regeneration process
MAX_REGEN_TIME	Maximum time allowed during a regeneration process
GGA_ON_TEMPERATURE	maximum CE temperature that allows the GGA to be turned ON



8.5.3. The PID algorithm

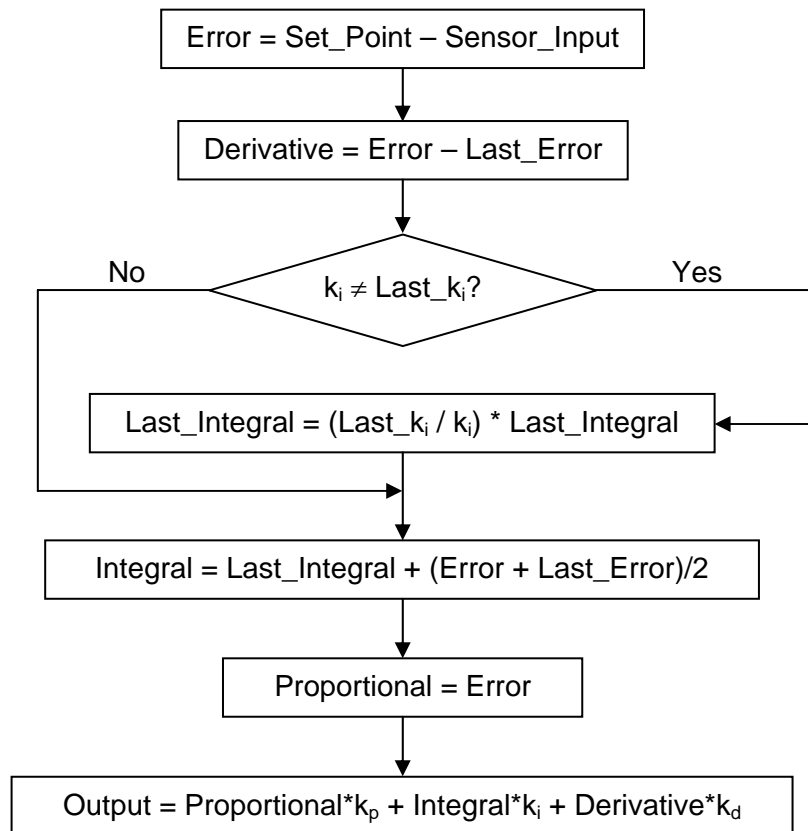



8.5.4. The OPEN LOOP algorithm

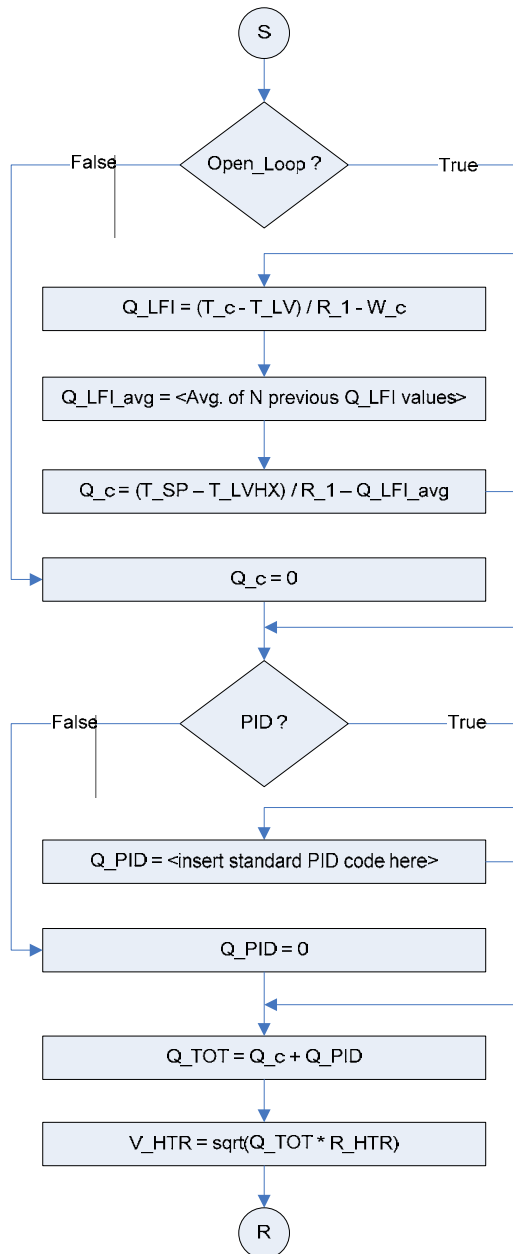

```

if (Open_Loop == TRUE)
  Q_LFI = (T_c - T_LVHX) / R_1 - W_c
  Q_LFI_avg = <Average of N previous Q_LFI values>
  Q_c = (T_SP - T_LVHX) / R_1 - Q_LFI_avg
else
  Q_c = 0
endif

if (PID == TRUE)
  Q_PID = <Standard PID code goes here>
else
  Q_PID = 0
endif

Q_TOT = Q_c + Q_PID
V_HTR = sqrt(Q_TOT * R_HTR)
  
```

Parameter	Description
T_c	Control Stage Temperature (T05, T06)
T_LV	LVHX-2 Temperature (T03, T04)
T_SP	Control Stage Setpoint (user-input)
R_1	Thermal resistance between Tc and T _{LVHX}
W_c	Measured power of control heater (H31, H32)
Q_c	Required control heater output (W)
Q_LFI	Calculated current LFI heat load (W)
N	Number of previous Q_LFI values to average
Q_LFI_avg	Calculated average LFI heat load (W)
Q_PID	Required control heater output from PID loop (W)
Q_TOT	Combined open loop and PID heater output (W)
R_HTR	Control heater resistance (Ohms)
V_HTR	Required control heater voltage output (V)
Open_Loop	Open loop control enable flag (TRUE = ON)
PID	PID control enable flag (TRUE = ON)



8.5.5. The BAD BED DETECTION algorithm

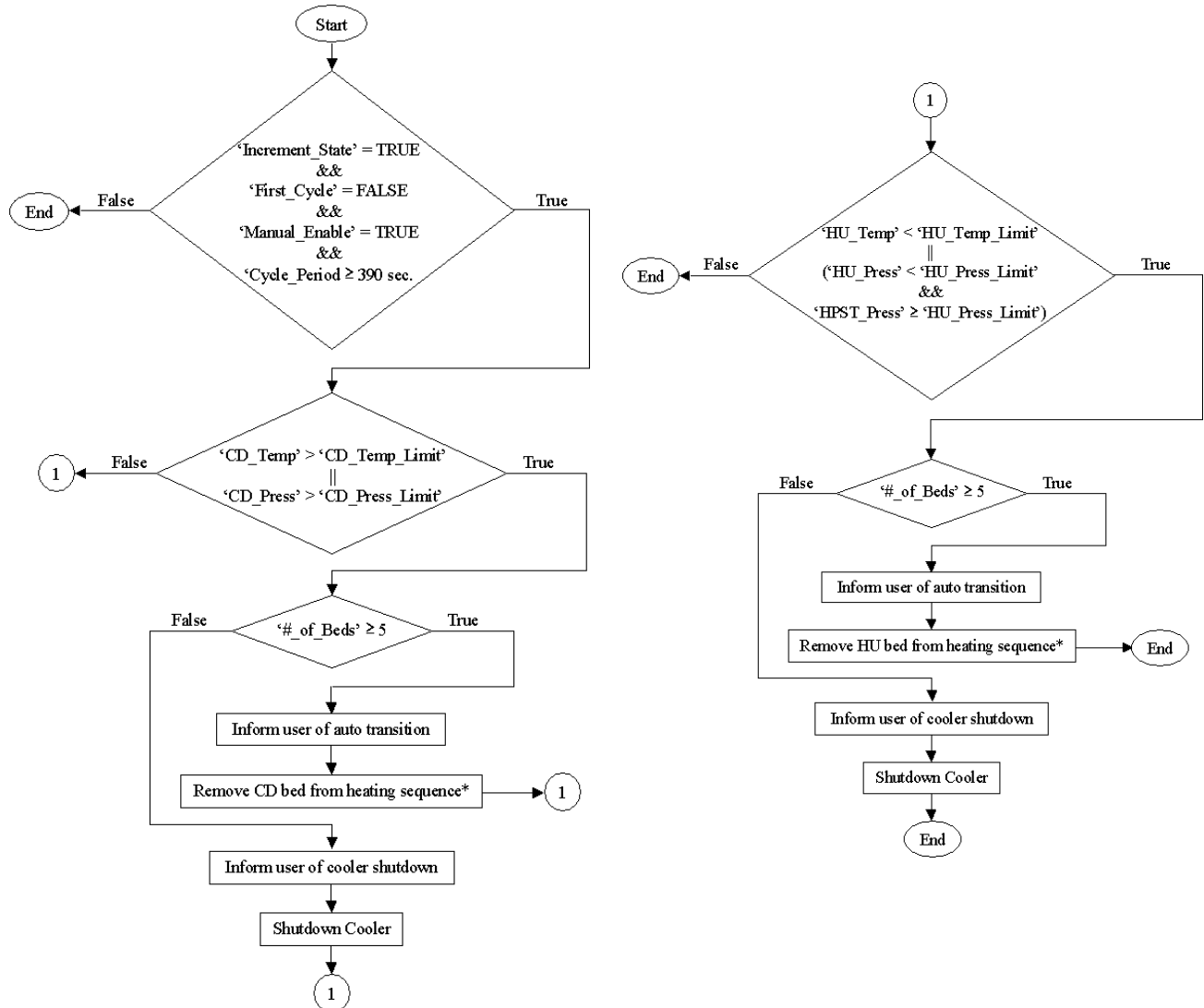

Parameter	Usage
Increment_State	This is the flag that signals the software to switch beds. It is set to TRUE whenever a bed change (i.e. state increment) is needed (e.g. elapsed cycle time reaches 667 seconds)
First_Cycle	This flag is set to TRUE when the cooler is first started (i.e. heaters turned on for the first time). Once the first bed change (state change) is made, the flag is cleared to FALSE, and remains this way indefinitely.
Manual_Enable	This is a switch on the user interface which allows the user to turn Bad Bed detection on (TRUE) and off (FALSE).
Cycle_Period	This holds the current cycle period in units of seconds (nominally 667 sec).
CD_Temp	This indicates the temperature of the bed which is currently in Cooldown.
CD_Temp_Limit	This is a control on the user interface. It should be set to a temperature that a properly functioning bed cools to within roughly 390 seconds (nominally 330K).
CD_Press	This indicates the pressure of the bed which is currently in Cooldown.
CD_Press_Limit	This is a control on the user interface. It should be set to a pressure that a properly



	cooling bed falls to within roughly 390 seconds (nominally 100psi).
HU_Temp	This indicates the temperature of the bed which is currently in Heatup.
HU_Temp_Limit	This is a control on the user interface. It should be set to a temperature that a properly heating bed heats to within roughly 390 seconds (nominally 330K).
HU_Press	This indicates the pressure of the bed which is currently in Heatup.
HU_Press_Limit	This is a control on the user interface. It should be set to a pressure that a properly heating bed rises to within roughly 390 seconds (nominally 100psi).
HPST_Press	This indicates the pressure in the high-pressure manifold of the cooler.
#_of_Beds	This holds the current number of beds in operation (e.g. 4, 5, or 6).

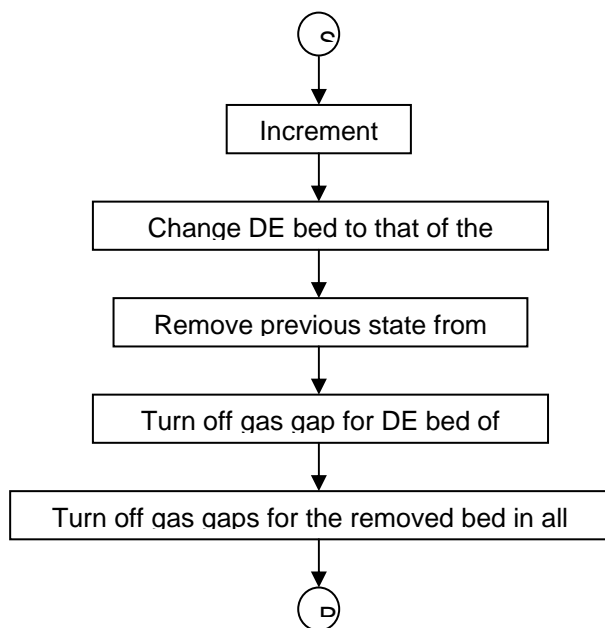

Removal of failed heatup bed.

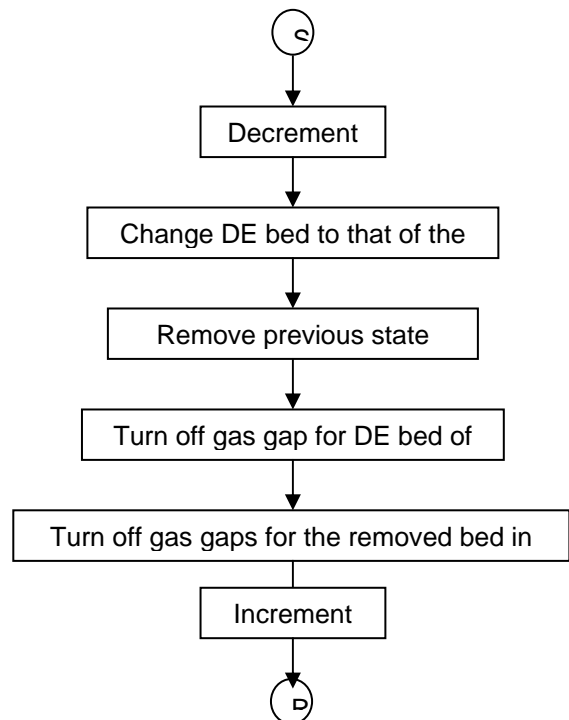

Removal of failed cooldown bed.



8.6. The LookUp Table

The LookUp Table is file containing all parameters needed by the SCE to control and monitor the SCS. For this reason, it is the basic tool of control from the Operator point of view. Any change to the cooler parameters can be done only by updating and uploading the LookUp Table.

The LookUp Table for the SCS FM units is shown in APPENDIX 1.



9. Planck SCS Operation Procedures

In this chapter a description of the cooler procedures is given. With the term “procedure” a sequence of operations to perform a specific task is indicated. Such sequence usually contains:

- ⇒ Tele-Command calls
- ⇒ Telemetry calls (includes TM packets and other info as defined in the database)
- ⇒ Comment fields

SCS procedures have been built on the basis of the ‘building block’ approach, making use of elementary blocks of procedure that are common to several processes. Each of these blocks is a self-contained procedure and is then referred to by the “higher-level” procedures. The list and description of SCS “building blocks procedures” is reported in Par. 9.1

SCS Operating Procedures (assembled from the building blocks) can be divided into two main categories:

1. Nominal Procedures
2. Contingency Procedures

The list and description of the SCS Operating Procedures form the subject of Par. 1.2.

9.1. SCS Procedure Blocks

SCS procedure blocks are listed in the Table below:

Procedure	Name	Description	N/R	Comments
BOOT	SCE Boot	SCE Switch ON and Boot	N&R	Activation of SCS, system BOOT, ASW transfer
INIT	SCS Enter INIT	Transition to INIT Mode	N&R	Initialization of system
LUT_UP	LUT Upload	Load LUT in memory	N&R	Optional step. Needed if is required a change in SCS parameters
LUT_DU	LUT Dump	Dump LUT values	N&R	Dump of LUT values for checking
READY_HM	HealthMonitoring	Enter READY Mode in Health Monitoring State	N&R	READY state for system monitoring. No cooler cycle is performed
READY_HC	HealthCheck	Start HealthCheck process in READY Mode	N&R	READY state for HealthCheck.
RUN	SCS Enter RUN	SCS start-up	N&R	Cooler start-up, compressor cycling enabled
SHUTDOWN	SCS Shutdown	Stop SCC cycle, remove power to compressor	N&R	SCS is monitored but power to compressor is shut off. Necessary to reboot system

Table 9-1

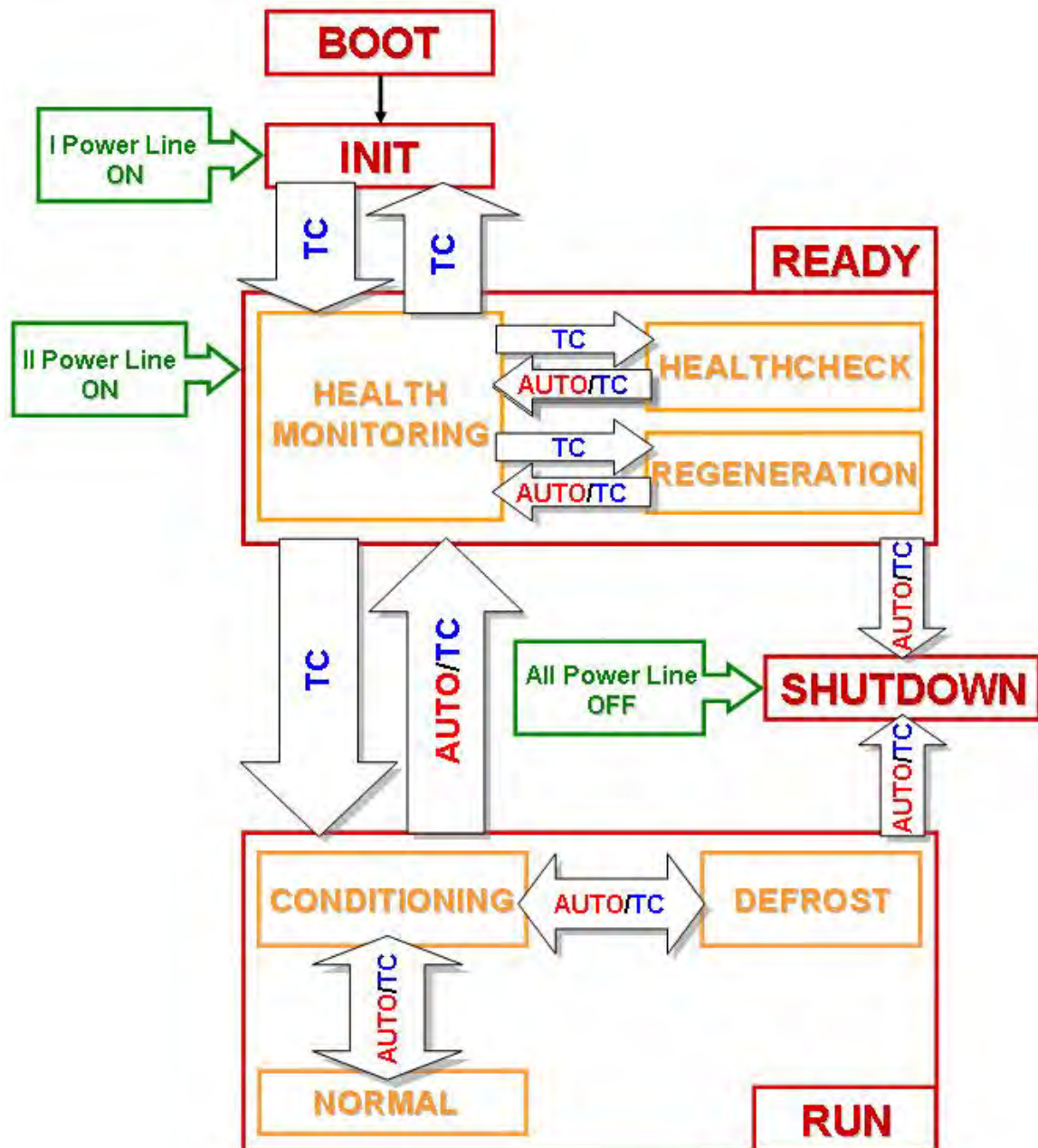

Figure 9-1 Planck SCS Operation Modes Diagram

All procedures described in this Chapter are valid for both Nominal (SCS-N) and Redundant (SCS-R) units. They differ by the packets APID number:

- ▶ SCS-N packets APID for Boot and Essential HK is 1664, for non-Essential and Diagnostic is 1666
- ▶ SCS-R packets APID for Boot and Essential HK is 1665, for non-Essential and Diagnostic is 1667



9.1.1. SCE BOOT (BOOT)

This procedure is automatically executed at the SCE switch on when the LCL#54 (for SCS-N) or LCL#53 (for SCS-R).are activated.

Applicative Software (ASW) transfer can be performed automatically or by “manual” TC (it depends on the lookup table settings)

NO TM(5.1) ID = 1 packet is generated and sent in BOOT Mode

Step #	Description	Type	Action	Result
1	CDMS Action: Turn ON Powerline 1		CDMS Action	5A line LCL#54 for SCS-N, LCL#53 for SCS-R
2	SCE auto entrance in BOOT MODE			Time interval between LCL activation and BOOT Mode entering is about 10s
2.1	Check BOOT Mode transition	TM(3.25)	SM702530 = BOOT	
2.2	Boot SW HK	TM(3.25)	SA010530, SM700530 and SM701530	Receive Packet 190301530 APID=1664/5, PI1=1, HSK1 Boot SW
2.3	Boot SW diagnostic	TM(3.26)	SA021530	Receive Packet 190311530 APID=1666/7, PI1=1, Diag1 Boot
3	Transfer ASW (can be automatic or by TC, depending on LUT settings)	TC(8.4)	SC000530, Transfer ASW (SM505530=1) - CVS_ID=4	Transfer ASW = transferred (SM291530=0) - CVS_ID=5
3.1	Wait for TC acknowledgment TM(1.1)	TM(1.1)	1 - TM(1.1)	TM(1.1) - CV_ID=1
3.2	Check ASW transfer completion	TM(3.26)	SM706530=TRANSFER SM291530=NO ERROR	Duration of transfer is about 50s. No TM is received during this period

Table 9-2

Note:

SCS-Redundant packets APID for Boot and Essential HK is 1665, for non-Essential and Diagnostic is 1667

9.1.2. SCS INIT (INIT)

Transition into INIT Mode can happen only after:

- ▶ 'GOTO INIT' TC from BOOT (or INIT or READY) Mode
- ▶ ASW transfer (automatically or by command) in BOOT Mode has been completed



It follows that the only way to enter INIT Mode is by sending the 'GOTO INIT' TC. This TC is not accepted if ASW has not been previously transferred.

Reception of TM(5.1) ID = 2 ensures that the transition into INIT Mode has been completed.

IMPORTANT

Report TM(5.1) ID=2 is not sent when entering INIT from BOOT. Event Report TM(5.1) ID=2 is always sent when entering INIT from all other Modes.

Before transition to INIT Spacecraft FDIR must be disabled and re-enabled after transition is complete. This is because ASW transfer and diagnostic checks suspend TM generation for more than 30 s. This can trigger a DLL OBCP in the CDMS.

Step #	Description	Type	Action	Result
0	<i>Disable S/C FDIR</i>	CDMS	Disable S/C FDIR	
1	GOTO INIT	TC(8.4)	SC006530, GoTo Init, SID=210,	Current State=Init (SM502530=2) - CVS_ID=8
1.1	Wait for TC acknowledgment TM(1.1)	TM(1.1)	1 - TM(1.1)	TM(1.1) - CV_ID=1
1.2	Event Report Reception: INIT Mode entered (if not from BOOT)	TM(5.1) Event Report	SA060530 ID = 2, P11 = 2 Init Mode entered	Receive Packet 190501530 APID=1664/5, P11 = 2
	<i>ASW Initialisation starts</i>			
1.3	ASW HK non-essential/essential	TM(3.25)		Receive Packet 190302559 APID=1666/7, P11=2, HSK2 non-essential ASW Receive Packet 190302559 APID=1664/5, P11=3, HSK3 essential ASW
1.4	ASW diagnostic	TM(3.26)	SA022530, DIAG2 ASW	Receive Packet 190312530 APID=1666/7, P11=2, Diag2 ASW
2	<i>Re-Enable S/C FDIR</i>	CDMS	Enable S/C FDIR	
3	<i>Perform Time Synch, if needed</i>			Time Synch TC to CDMS

Table 9-3

Notes:

- Step 1.2 - Event Report TM(5.1) ID=2 is not sent when entering INIT from BOOT
- Step 1.4 - Packet TM(3.26) ASW Diagnostic is sent only if HW test is performed
- SCS-Redundant packets APID for Boot and Essential HK is 1665, for non-Essential and Diagnostic is 1667



9.1.3. LUT Upload (LUT_UP)

LUT upload is not mandatory. A LUT upload should be executed only if parameters need to be changed; if no change is applied the ASW uses the parameters stored in EEPROM.

Step #	Description	Type	Action	Result
1	LUT Memory Load	TC(6.2)	See LUT Upload TC Table 9-5	
1.1	Wait for TC acknowledgment TM(1.3)	TM(1.3)	10 - TM(1.3), TC started	TM(1.3) - CVS_ID=2
1.2	Wait for TC acknowledgment TM(1.7)	TM(1.7)	10 - TM(1.7), TC completed	TM(1.7) - CVS_ID=3

Table 9-4

Dedicated LUT Upload TC depends on the model of SCE used.

CCF Name	Description	# of Param	Memory ID	Start Address	Length
SC501530	TC 6_2 Load LUT Software – FM1, FM2, PFM1 and PFM2	66	DM EEPROM 5 (0x8004)	100	48
SC502559	TC 6_2 Load LUT Powers and Times – FM1, FM2, PFM1 and PFM2	43		130	38
SC503559	TC 6_2 Load LUT Health Check and Regeneration – FM2	21		156	16
SC504559	TC 6_2 Load LUT Run Mode transitions – FM2	30		166	25
SC505559	TC 6_2 Load LUT Fault Conditions and Bad Bed Detection – FM2	34		17F	29
SC506559	TC 6_2 Load LUT PID and Open Loop Algorithms – FM2	17		19C	12
SC507559	TC 6_2 Load LUT Heaters Resistances – FM1, FM2, PFM1 and PFM2	32		1A8	27
SC508530	TC 6_2 Load LUT Calibrations 1 – FM1, FM2, PFM1 and PFM2	35		1C3	30
SC509530	TC 6_2 Load LUT Calibrations 2 – FM1, FM2, PFM1 and PFM2	41		1E1	36
SC510559	TC 6_2 Load LUT health Check and Regeneration – FM1	21		156	16
SC511559	TC 6_2 Load LUT Run Mode transitions – FM1	30		166	25
SC512559	TC 6_2 Load LUT Fault Conditions and Bad Bed Detection – FM1	34		17F	29
SC513559	TC 6_2 Load LUT PID and Open Loop Algorithms – FM1	17		19C	12
SC514559	TC 6_2 Load LUT health Check and Regeneration – PFM2	21		156	16
SC515559	TC 6_2 Load LUT Run Mode transitions – PFM2x	30		166	25
SC516559	TC 6_2 Load LUT Fault Conditions and Bad Bed Detection – PFM2	34		17F	29
SC517559	TC 6_2 Load LUT PID and Open Loop Algorithms – PFM2	17		19C	12



SC518559	TC 6_2 Load LUT health Check and Regeneration – PFM1	21	156	16
SC519559	TC 6_2 Load LUT Run Mode transitions – PFM1	30	166	25
SC520559	TC 6_2 Load LUT Fault Conditions and Bad Bed Detection – PFM1	34	17F	29
SC521559	TC 6_2 Load LUT PID and Open Loop Algorithms – PFM1	17	19C	12

Table 9-5

The parameter for each LUT upload TC will be transmitted to MOC in TPF files, according to the agreed process.

9.1.4. LUT Dump (LUT_DU)

Step #	Description	Type	Action	Result
1	LUT Memory Dump	TC(6.5)	See LUT Dump TC Table 9-7	
1.1	Wait for TC acknowledgment TM(1.3)	TM(1.3)	10 - TM(1.3), TC started	TM(1.3) - CVS_ID=2
1.2	Wait for TC acknowledgment TM(1.7)	TM(1.7)	10 - TM(1.7), TC completed	TM(1.7) - CVS_ID=3
1.3	LUT Read Back TM		See LUT Read Back TM Table	

Table 9-6

CCF Name	Description
SC601530	TC 6_5 Dump LUT Software
SC602559	TC 6_5 Dump LUT Powers and Times
SC603559	TC 6_5 Dump LUT health Check and Regeneration
SC604559	TC 6_5 Dump LUT Run Mode transitions
SC605559	TC 6_5 Dump LUT Fault Conditions and
SC606559	TC 6_5 Dump LUT PID and Open Loop
SC607559	TC 6_5 Dump LUT Heaters Resistances
SC608530	TC 6_5 Dump LUT Calibrations 1
SC609530	TC 6_5 Dump LUT Calibrations 2

Table 9-7

Name	Description	LUT position	Monitoring Parameter	Command Parameter
SA100530	LUT SOFTWARE	0x00 to 0x2f	SM325530 to SM384530	SP101530 to SP168530
SA102559	LUT Powers Times	0x30 to 0x55	SM201540 to SM238540	SP001540 to SP038540
SA103559	LUT HC Regen	0x56 to 0x65	SM239540 to SM254540	SP039540 to SP055540
SA104559	LUT Run Mode	0x66 to 0x7e	SM255540 to SM279540	SP056540 to SP080540
SA105559	LUT Faults	0x7f to 0x9b	SM280540 to SM308540	SP081540 to SP109540
SA106559	LUT PID	0x9c to 0xa7	SM309540 to SM320540	SP110540 to SP121540
SA107559	LUT Heaters	0xa8 to 0x2	SM321540 to SM347540	SP121540 to SP148540



SA108530	LUT Calibrations 1	0xc3 to 0xe0	SM385530 to SM414530	SP169530 to SP199530
SA109530	LUT Calibrations 2	0xe1 to 0x104	SM415530 to SM450530	SP200530 to SP235530

Table 9-8

9.1.5. READY – HealthMonitoring (READY_HM)

This procedure describes the steps needed to enter in Ready Mode and start monitoring the cooler status through the pressure and temperature sensors.

When the system enters into Ready Mode (see Figure 9-1), the health monitoring process is automatically performed: it consists in the readout of all the system sensors (T and P) at 1 Hz, checking that all the values result are within the limits relative to the coolers present condition (i.e. first start or re-start).

Reception of TM(5.1) ID = 3 ensures that the transition into READY (Health Monitor) Mode has been completed.

Step #	Description	Type	Action	Result
1	GOTO READY	TC(8.4)	SC007530, Goto Ready - Health Monitor, SID=220,	Current State= Health Monitor (SM502530=3) - CVS_ID=9
1.1	Wait for TC acknowledgment TM(1.1)	TM(1.1)	1 - TM(1.1)	TM(1.1) - CV_ID=1
1.2	Event Report Reception: READY Mode entered	TM(5.1) Event Report	SA060530 ID = 3, PI1 = 3 Ready Mode (Health Monitor) entered	Receive Packet 190501530 APID=1664/5, PI1 = 3
1.3	ASW HK non-essential/essential	TM(3.25)	Read: SA011559, SA012540, SA013540, SA014540, SA005540, SA090559, SA091540. Check Parameter list for details	Receive Packet 190302559 APID=1666/7, PI1=2, HSK2 non-essential ASW Receive Packet 190302559 APID=1664/5, PI1=3, HSK3 essential ASW
1.4	ASW Diagnostic	TM(3.26)	SA022530, DIAG2 ASW	Receive Packet 190312530 APID=1666/7, PI1 = 2
2	<i>Perform Time Synch, if needed</i>			Time Synch TC to CDMS

Table 9-9

Note:

- Step 1.4 - Packet TM(3.26) ASW Diagnostic is sent only if HW test is performed
- SCS-Redundant packets APID for Boot and Essential HK is 1665, for non-Essential and Diagnostic is 1667

9.1.6. READY – HealthCheck (READY_HC)

The purpose of the Health-check procedure is to check the status of the Planck Sorption Cooler System both in flight and on the ground. The check consist in verifying that all the heater circuits (CE's, LPSB, JT, etc.) are functioning properly (current goes through the heater circuit and, if



possible, the respective temperature or pressure is changed as expected). The health check procedure will perform all the verifications on the heating circuit but will not make any system decision on its results. The ground operator, comparing those data with previous run and with proper parameter ranges (defined by the SCS conditions) will decide on the status of the system and on how to operate the cooler.

Health Check (HC) procedure is entered by sending the "GOTO Health Check" TC (see Figure 9-1) from the Health Monitor state of READY Mode. During the HC process, a periodic diagnostic TM(3.26) "Health Check Diagnostic" is sent once a second reporting the test being performed and the previous tests status (since the start of the HC procedure). The result of the overall HC procedure is given on the last TM(3, 26) diagnostic sent following the automatic transition from HC back to READY Health Monitor.

The Health Check procedure is fully automatic and at the end of the process the software autonomously returns into Health Monitor state. It is anyway possible to stop the HC procedure manually and return to Health Monitor state with the "GOTO READY Health Monitor" TC.

The HC procedure parameters used for the system test are defined in the Lookup Table (Health Check procedure Section).

The detailed steps of the HC process are reported in Chapter 8.

Step #	Description	Type	Action	Result
1	GOTO HEALTHCHECK	TC(8.4)	SC008530, GoTo Ready - Health Check, SID=230	Current State= Health Check (SM502530=4) - CVS_ID=10
1.1	Wait for TC acknowledgment TM(1.1)	TM(1.1)	1 - TM(1.1)	TM(1.1) - CV_ID=1
1.2	Event Report Reception: READY Mode (Health Check) entered	TM(5.1) Event Report	SA060530 ID = 4, P11 = 4 Ready Mode (Health Check) entered	Receive Packet 190501530 APID=1664/5, P11 = 4
1.3	ASW HK non-essential/essential	TM(3.25)	Read: SA011559, SA012540, SA013540, SA014540, SA005540, SA090559, SA091540. Check Parameter list for details	Receive Packet 190302559 APID=1666/7, P11=2, HSK2 non-essential ASW Receive Packet 190302559 APID=1664/5, P11=3, HSK3 essential ASW
1.4	Health Check Diagnostic	TM(3.26)	SA023530 DIAG3 - HEALTH CHECK	Receive Packet 190313530 APID=1666/7, P11 = 3

Table 9-10

Note:

SCS-Redundant packets APID for Boot and Essential HK is 1665, for non-Essential and Diagnostic is 1667

IMPORTANT:

HEALTHCHECK Step1, LPSB H7 Sustain Heater Test, is performed by using power value 0x48 POWER_LPSB and NOT H7 max power. 0x48 POWER_LPSB should always be set higher than 1 W to have a successful HealthCheck step#1.



9.1.7. SCS RUN (RUN)

The SCS RUN is the procedure that starts running the cooler. Once the procedure is started, it is automatically carried on by the software (see Chapter 8) until the cooler enters in Nominal Operations. Once the conditions defined in the LUT for entering Nominal State are reached, the software automatically takes the TMU into Nominal Operations.

Step #	Description	Type	Action	Result
0	Check that SCS status is far from Faults conditions defined in LUT. If not, perform COOLDOWN process before going into RUN.		High P & Bed P < 10bar Bed Temperature < 315K LPSB T < 320K	SM044540 – SM050540 < 10bar SM034540 – SM039540 < 315K SM031540 & SM032540 < 320K
1	GOTO RUN	TC(8.4)	SC010530, GoTo Run - Startup, SID=250	Current State =startup (SM502530 = 6) – CVS_ID = 12
1.1	Wait for TC acknowledgment TM(1.1)	TM(1.1)	1 - TM(1.1)	TM(1.1) - CV_ID=1
1.2	Event Report Reception: READY Mode entered	TM(5.1) Event Report	SA060530 ID = 6, PI1 = 6 Run Mode (Startup) entered	Receive Packet 190501530 APID=1664/5, PI1 = 6
1.3	ASW HK non-essential/essential	TM(3.25)	Read: SA011559, SA012540, SA013540, SA014540, SA005540, SA090559, SA091540. Check Parameter list for details	Receive Packet 190302559 APID=1666/7, PI1=2, HSK2 non-essential ASW Receive Packet 190302559 APID=1664/5, PI1=3, HSK3 essential ASW
1.4	ASW Diagnostic	TM(3.26)	SA022530, DIAG2 ASW	Receive Packet 190312530 APID=1666/7, PI1 = 2

Table 9-11

Note:

- **Step 1.4 - Packet TM(3.26) ASW Diagnostic is sent only if HW test is performed**
- **SCS-Redundant packets APID for Boot and Essential HK is 1665, for non-Essential and Diagnostic is 1667**

9.1.8. SCS Shutdown (SHUTDOWN)

The SHUTDOWN procedure is used only in contingency cases. This process shut the TMU down definitively, so that it cannot be reactivated unless the whole SCS is restarted by re-boot.

Shutdown Mode is reached by the “GOTO Shutdown” TC from READY or RUN Modes. The System can also enter into this Mode automatically if one of the following conditions is true:

- ▶ both ADC reading chains are bad.
- ▶ JT heaters H34 or H35 is always ON (detection in RUN Mode only).
- ▶ Electronics temperature reached the second level limit (detection in RUN Mode only)



Note: in all cases, the “switch off” event is also sent to CDMS.

Step #	Description	Type	Action	Result
1	GOTO SHUTDOWN	TC(8.4)	SC013530, GoTo Shutdown, SID=280,	Current State= Shutdown (SM502530=9) - CVS_ID=15
1.1	Wait for TC acknowledgment TM(1.1)	TM(1.1)	1 - TM(1.1)	TM(1.1) - CV_ID=1
1.2	Event Report Reception: SHTUDOWN Mode entered	TM(5.1) Event Report	Check SA060530, SM311530=Shutdown, TM(5.1) PI1 = 9 Shutdown Mode entered	Receive Packet 190501530 APID=1664/5, PI1 = 9
	<i>Request to CDMS: 2nd Power line (20A) OFF</i>		<i>Automatically performed by OBCP</i>	
	<i>SCS is now in READY mode (Health Monitor) but cannot enter other Modes. The system must be switched OFF</i>			
1.3	ASW HK non-essential/essential	TM(3.25)	Read: SA011559, SA012540, SA013540, SA014540, SA005540, SA090559, SA091540. Check Parameter list for details	Receive Packet 190302559 APID=1666/7, PI1=2, HSK2 non-essential ASW Receive Packet 190302559 APID=1664/5, PI1=3, HSK3 essential ASW
1.4	ASW Diagnostic	TM(3.26)	SA022530, DIAG2 ASW	Receive Packet 190312530 APID=1666/7, PI1 = 2
	<i>Request to CDMS: 1st Power line (5A) OFF</i>			<i>SCE LCL#54 (SCS-N) or LCL#53 (SCS-R) Switch OFF</i>

Table 9-12

Note:

- **Step 1.4 - Packet TM(3.26) ASW Diagnostic is sent only if HW test is performed**
- **SCS-Redundant packets APID for Boot and Essential HK is 1665, for non-Essential and Diagnostic is 1667**



9.2. SCS Operating Procedures

9.2.1. SCS Nominal Procedures

Procedure	Description	N/R	Comments
SCE_INIT	Transition OFF to INIT	N&R	Used to initialise SCE
READY_HM	SCS Health monitoring	N&R	From OFF to Health monitoring
READY_HC	SCS Health Check	N&R	From OFF to Health Check process
START_UP	SCS Startup	N&R	From OFF to RUN
COOLDOWN	SCS depressurization	N&R	Depressurization before Switch Off
SWITCH_OFF	SCS Nominal Shutdown	N&R	Nominal Switch Off procedure

Table 9-13

9.2.1.1. System Initialization (SCE_INIT)

This higher level procedure is used only to initialise the SCS, to perform diagnostic checks and/or to upload a new LUT.

Step #	Description	Comments
1	Execute BOOT procedure <i>Transfer ASW if not automatically executed</i>	
2	Execute INIT Procedure	
3	Execute LUT_UP, if needed	Optional Step for Uploading new LUT

Table 9-14

9.2.1.2. SCS in HealthMonitoring (READY_HM)

This Procedure can be used to enter the SCS Monitoring state: the sorption cooler cannot be run but all its sensor lines status can be monitored.

Step #	Description	Comments
1	Execute BOOT Procedure <i>Transfer ASW if not automatically executed</i>	
2	Execute INIT Procedure	
3	Execute LUT_UP, if needed	Optional Step for Uploading new LUT
4	Execute READY_HM Procedure	

Table 9-15



9.2.1.3. Execute SCS HealthCheck (READY_HC)

The HealthCheck Procedure can be used to perform SCS Health Check: the completion of the process without errors ensures that all SCS subsystems are nominally functioning.

Step #	Description	Comments
1	Execute BOOT Procedure <i>Transfer ASW if not automatically executed</i>	
2	Execute INIT Procedure	
3	Execute LUT_UP, if needed	Optional Step for Uploading new LUT
4	Execute READY_HM Procedure	HC process is started from READY HM
5	Execute READY_HC Procedure	

Table 9-16

9.2.1.4. Cooler Start-up (START_UP)

START_UP is the procedure that starts running the compressor cycle, taking to cooler first in CONDITIONING State and then, after the limits defined in the LUT are reached, automatically into Normal Operations.

IMPORTANT

If this is the first start-up after a long time (more than 12 hours), no special check on cooler status is required before starting the system except for the usual health monitoring.

If this is a re-start after (within 12 hours) SCS cycle has been stopped or after a REGENERATION process, it is important to check that SCS parameters are well within the Faults conditions defined in LUT (Faults Section) before restarting the system. In particular, it should be verified that:

- ▶ Beds Pressure (SM044540 – SM049540) < 8 bar
- ▶ High Pressure (SM050540) < 8 bar
- ▶ Beds Temperature (SM034540 – SM039540) < 310 K
- ▶ LPSB Temperature (SM031540 & SM032540) < 310 K

If these conditions are not met it is required to RUN from 2 to 4 Cooldown cycles (see Par 9.2.1.5) before restarting the cooler with the nominal LUT.



Step #	Description	Comments
1	Execute BOOT Procedure <i>Transfer ASW if not automatically executed</i>	
2	Execute INIT Procedure	
3	Execute LUT_UP, if needed	Optional Step for Uploading new LUT
4	Execute READY_HM Procedure	
5	Execute RUN Procedure	

Table 9-17

9.2.1.5. SCS Cooldown Process

If the cooler has been cycled in RUN Mode (Nominal or Conditioning) at high pressure, before SCS shutdown it is advisable to leave the system in a low pressure condition. A procedure to quickly depressurize the system and allow a balanced gas distribution in all hydride beds should be applied. Such procedure is based on removing all power from the compressor elements heater and connecting the beds to the Warm Radiator. Since it is not possible to energize all GGA at the same time, the easiest way is to cycle the TMU with zero input power to the compressor heaters for 2-4 cycles with a 390s cycle time.

This process is NOT necessary if cooler is switched off after READY- HealthMonitoring or READY – HealthCheck with high pressure value P7 (SM050540) below 8 bar.

Step #	Description	Action	Comments
1	Execute LUT_UP. All heaters power set to zero in LUT_Power and Times Section. Cycle Time set to 390s	SC502559, Load LUT Power & Times.	TPF files to be delivered by SCS IOT
2	Execute RUN Procedure		Run 2 to 3 cycles

Table 9-18

9.2.1.6. SCS Switch Off (SWITCH_OFF)

The Shutdown procedure stops the system by sending it into
The cooler cycle can be stopped at any time by sending the GOTO Ready command that sends the TMU in Health Monitoring. With the GOTO Run TC the TMU can be returned to run operations.

The Nominal Switch Off procedure does not make use of the Shutdown



Step #	Description	Comments
0	<i>Execute COOLDOWN Procedure</i>	Only if cooler has been run at high pressure (RUN Mode or Regeneration). See Par. 9.2.1.5.
1	<i>Execute READY_HM Procedure</i>	
2	<i>Execute INIT Procedure</i>	This will automatically disable the 2nd PowerLine (20A): LCL#63,64,65,66 for SCS-R or LCL#67,68,69,70 for SCS-N
3	<i>Request to CDMS: 1st Power line (5A), LCL#54 for SCS-N or LCL#53 for SCS-R, OFF</i>	SCS is shutdown

Table 9-19

9.2.2. SCS Contingency Procedures

With Contingency Procedures all those actions (planned or not) to be started following a contingency are indicated. SCS OBSW is robust enough to autonomously react to all expected contingency or failures by either taking the system in a safe mode (READY-HM) or by Shutdown. There are several contingency processes that may be required from ground during operations. Some of them are planned in advance, such as Regeneration or Switchover, some other need to be performed as a consequence of a not successful autonomous response (Shutdown, for example) or to restart the system after a recovered failure (e.g. Set bed or device state).

Procedure	Description	N/R
DEFROST	Manual Defrost of JT	N/R
REGEN	Regeneration	N/R
SWITCHOVER	Switchover between the two units	N/R
BED_STATE	Set bed state good to bad to good	N/R
DEV_STATE	Set device state good to bad to good	N/R
SET_INITIAL_BED	Set the initial bed for Heatup	N/R
RETURN_TO_INITIAL_BED	Return to initial bed setting	N/R
SHUTDOWN	Contingency Shutdown	N/R

Table 9-20

9.2.2.1. Manual Defrost Procedure (DEFROST)

SCS OBSW autonomously detects JT plugs and recovers by an automatic process triggered by limits defined in LUT.



JT clogging defrost process can also be activate manually through the below procedure in case autonomous response has not been successful or if the automatic response of the system has been disabled in the LUT.

Step #	Description	Type	Action	Result
1	GOTO RUN Defrost	TC(8.4)	SC011530, GoTo RUN - Defrost, SID=260	Current State= Defrost (SM502530=7) - CVS_ID=0013
1.1	Wait for TC acknowledgment TM(1.1) and TM(1.3)	TM(1.1) & TM(1.3)	1 - TM(1.1)	TM(1.1) - CV_ID=1
1.2	Event Report Reception: RUN Mode (Defrost) entered	TM(5.1) Event Report	SA060530 ID = 7, PI1 = 7 RUN Mode (Defrost) entered	Receive Packet 190501530 APID=1664/5, PI1 = 7
1.3	ASW HK non-essential/essential	TM(3.25)	Read: SA024530 Check: SA060530, SA090559, SA011559, SA012540, SA013540, SA014540, SA005540, SA091540. Check Parameter list for details	Receive Packet 190302559 PI1=2, HSK2 non-essential ASW Receive Packet 190302559 PI1=3, HSK3 essential ASW
2	<i>Wait until JT T reaches 100K or limit defined by Operator</i>		Monitor SD031540 (T7 or T30), in SA013540	
3	GOTO RUN (Startup)	TC(8.4)	SC010530, GoTo Run - Startup, SID=250	Current State =startup (SM502530 = 6) – CVS_ID = 12
3.1	Wait for TC acknowledgment TM(1.1) and TM(1.3)	TM(1.1) & TM(1.3)	1 - TM(1.1)	TM(1.1) - CV_ID=1
3.2	Event Report Reception: READY Mode entered	TM(5.1) Event Report	SA060530 ID = 6, PI1 = 6 Run Mode (Startup) entered	Receive Packet 190501530 APID=1664/5, PI1 = 6

Table 9-21

9.2.2.2. Regeneration Procedure (REGEN)

The Regeneration Procedure is the process that can restore the hydrogen absorbing capability of the metal hydrides up to 99% of BOL conditions (see Chapter 8 for a detailed description of the steps).

Step #	Description	Type	Action	Result
1	GOTO READY Regeneration	TC(8.4)	SC009530, GoTo Ready - Regeneration, SID=240	Current State= Regeneration (SM502530=5) - CVS_ID=0011
1.1	Wait for TC acknowledgment TM(1.1)	TM(1.1)	1 - TM(1.1)	TM(1.1) - CV_ID=1
1.2	Event Report Reception: READY Mode	TM(5.1) Event	SA060530 ID = 5, PI1 = 5 Ready Mode	Receive Packet 190501530 APID=1664, PI1 = 5



	(Regeneration) entered	Report	(Regeneration) entered	
1.3	ASW HK non-essential/essential	TM(3.25)	Read: SA024530 Check: SA060530, SA090559, SA011559, SA012540, SA013540, SA014540, SA005540, SA091540. Check Parameter list for details	Receive Packet 190302559 PI1=2, HSK2 non-essential ASW Receive Packet 190302559 PI1=3, HSK3 essential ASW
1.4	Health Check Diagnostic	TM(3.26)	SA024530 DIAG3 - REGENERATION	Receive Packet 190314530, PI1 = 4

Table 9-22

9.2.2.3. Switchover Process (SWITCHOVER)

During flight operations both SCS units (N & R) will be operated in order to cover full lifetime requirements or mission extensions. For this reason a procedure to switch from one unit to the other (and vice-versa) has been implemented and tested on ground.

This is the top level procedure describing the steps of a possible SCS switch-over in flight.

The general sequence described below can be summarized in the following steps:

- Switch OFF LFI, if allowed (4K cooler and Dilution stay ON, TBC)
- Shutdown SCS Nominal
- Initialise SCS Redundant
- GOTO READY MODE, enter Health Monitoring
- GOTO RUN MODE
- Wait for SCS R to enter Nominal Operations
- Perform cooler tuning

The whole procedure can take up to 2 - 3 hrs (TBC), if only one tuning step is required to achieve quasi-steady state. Each extra tuning step can take about 30 min (up to two or three tuning step might be expected)

The interactive time needed is given by the different TCs sent: so from step 1 to 7 (this is about half an hour).

Time from cooler OFF to cooler ON is about half an hour BUT before the activated SCS starts producing enough cooling power, it can take about 2 hrs (TBC).



Step #	Description	Duration	Comments
	SCS-N (or R) is in RUN Mode		<i>Before starting procedure it may be requested to switch off LFI FEM's, if possible.</i>
1	Execute SCS N (or R) Switch Off Procedure <i>Including CDMS request for 5A line OFF</i> <i>Wait for Event Report from S/C</i>	2 min	4K Cooler and Dilution can stay ON (TBC) Now SCE N (or R) is OFF Practically instantaneous
2	Execute SCS R (or N) BOOT Procedure <i>Transfer ASW if not automatically executed</i> <i>Wait for Event Report from S/C</i>	3 min	CDMS request for 5A line ON Practically instantaneous
3	Execute SCS R (or N) INIT Procedure <i>Wait for Event Report from S/C</i>	3 min	ASW transfer included Practically instantaneous
4	Execute LUT upload, if needed	20 min	
5	Execute SCS R (or N) READY Procedure <i>Wait for Event Report from S/C</i> <i>Wait in READY Monitoring for TBD seconds</i>	1 min TBD	to Enter READY Practically instantaneous TBD can be zero
5a	Execute HEALTHCHECK Procedure (TBC)	1 hr	TBC if HC process is needed before activation
6	Execute SCS N RUN Procedure <i>Wait for HP to reach Nominal Ops Value</i>	1 min approx 2 hrs	to enter CONDITIONING Mode to enter NOMINAL Mode
7	Execute LUT upload, if needed	20 min	Cooler Tuning (1 or more steps could be needed)

Table 9-23



9.2.2.4. Set Bed State (BED_STATE)

This procedure is used to declare a bed as “bad” or “good”.

TC SC015530 can be send from any Mode except BOOT.

SCS FDIR actions may result in declaring one of the Beds as “bad”.

Step #	Description	Type	Action	Result
1	Set Bed State	TC(8.4)	SC015530, SID 401, Set Bed id Bits 0...3: Bed Number (0 to 5) to Bit 4..5: bed state (0=bad, 1=Run Normal Mode only, 2 or 3= good)	Check SA012540 for Bed status, SM893540- SM898540 and SM870540-SM875540 SM001540, SM002540
1.1	Wait for TC acknowledgment TM(1.1) and/or TM(1.3)	TM(1.1) & TM(1.3)	1 - TM(1.1)	TM(1.1) - CV_ID=1

Table 9-24

9.2.2.5. Set Device State (DEV_STATE)

This procedure is used to declare any SCS Device as “bad” or “good”.

TC SC016530 can be send from any Mode except BOOT.

SCS FDIR actions may result in declaring a Device as “bad”.

Step #	Description	Type	Action	Result
1	Set Device State	TC(8.4)	SC016530, SID=501, Set Device id Bit 0...11: Device number see Table 9-26 to Bit 12...15: device state (0=good, 1=bad)	Check SA090559, SA011559, SA012540 for Device status. SM738530-SM741530 SM800540-SM892540
1.1	Wait for TC acknowledgment TM(1.1) and/or TM(1.3)	TM(1.1) & TM(1.3)	1 - TM(1.1)	TM(1.1) - CV_ID=1

Table 9-25



Device	Value	Device	Value	Device	Value	Device	Value	Device	Value	Device	Value
ADC 0	0	H24	0xb	H14	0x16	T6	0x105	T17	0x110	T29	0x11b
ADC 1	1	H25	0xc	H15	0x17	T7	0x106	T18	0x111	T30	0x11c
H1	2	H26	0xd	H16	0x18	T8	0x107	T20	0x112	P1	0x200
H2	3	H8	0xe	H7	0x19	T9	0x108	T21	0x113	P2	0x201
H3	4	H33	0xf	H31	0x1a	T10	0x109	T22	0x114	P3	0x202
H4	5	H34	0x10	H32	0x1b	T11	0x10a	T23	0x115	P4	0x203
H5	6	H35	0x11	T1	0x100	T12	0x10b	T24	0x116	P5	0x204
H6	7	H36	0x12	T2	0x101	T13	0x10c	T25	0x117	P6	0x205
H21	8	H11	0x13	T3	0x102	T14	0x10d	T26	0x118	P7	0x206
H22	9	H12	0x14	T4	0x103	T15	0x10e	T27	0x119	P8	0x207
H23	0xa	H13	0x15	T5	0x104	T16	0x10f	T28	0x11a		

Table 9-26

Note:

- Devices from 0x000 to 0x0ff are heaters and ADC.
- Devices from 0x100 to 0x1ff are temperature sensors
- Devices from 0x200 to 0x2ff are pressure sensors

9.2.2.6. Set Initial Heatup Bed Position (SET_INITIAL_BED)

This procedure is used to set which bed should start in Heatup at beginning of cycling.

Step #	Description	Type	Action	Result
1	Set Initial Heatup Bed Position	TC(8.4)	SC014530, SID=301, Set Initial Heatup Bed id Bit 0..2: Heatup Bed id from 0 to 5 Bit 3...15: not used	Check SA012540 for Bed Status: SM893540-SM898540 SM870540-SM875540 SM001540, SM002540
1.1	Wait for TC acknowledgment TM(1.1) and/or TM(1.3)	TM(1.1) & TM(1.3)	1 - TM(1.1)	TM(1.1) - CV_ID=1

Table 9-27

9.2.2.7. Return to Initial Bed States (RETURN_TO_INITIAL_BED)

This TC restores the initial Bed positions in the cycle:

bed0 = Heatup, bed1 = Desorb, bed2 = Cooldown, bed3, bed 4 and bed 5 = Absorb

Step #	Description	Type	Action	Result
1	Set Device State	TC(8.4)	SC017530, SID=310. Return to Initial Bed Position, No parameters	Check SA012540 for Bed Status: SM893540-SM898540 SM870540-SM875540 SM001540, SM002540



1.1	Wait for TC acknowledgment TM(1.1) and/or TM(1.3)	TM(1.1) & TM(1.3)	1 - TM(1.1)	TM(1.1) - CV_ID=1
-----	---	-------------------	-------------	-------------------

Table 9-28

9.2.2.8. Transition into Shutdown Mode (SHUTDOWN)

This procedure should be applied in any occurrence of SCS contingency that takes the system close to its safety limits or if autonomous response has not been successful.

In case of SCS anomaly the usual response required to the operator is to send the unit back to READY-HM (by applying the READY_HM procedure) which is the "Safe State" of the system. If this is not possible for any reason or if this action does not stop or limit the anomalous behaviour, then the execution of SHUTDOWN procedure is required.

Step #	Description	Comments
1	Execute SCS SHUTDOWN Procedure	Basically is the GOTO Shutdown TC
	<i>SCS is now in a state identical to READY mode (Health Monitor) but cannot enter other Modes. The system must be switched OFF</i>	2 nd Power line (20A) is deactivated
	Request to CDMS: 1st Power line (5A) OFF	Switch Off LCL#54 for SCS-N or LCL#53 for SCS-R



10. Planck SCS Telemetry & Telecommand Data

10.1. Purpose and scope

This Chapter describes the TM format and summarizes the for the Sorption Cooler Electronics

For the list of all monitored TMU + SCE parameters see Appendix 2

10.2. General TM/TC structure

The first white row represents the field size. The second white row represents the field position in bits and the last white row represents the field value.

10.2.1. TC structure

Packet Header (48 bits)							Packet Data Field		
Packet ID				Packet Sequence Control		Packet Length	Data Field Header	Application Data	Packet Error Control
Version Number	Type	Data Field Header Flag	APID	Sequence Flag	Sequence Count				
3 bits	1 bit	1 bit	11 bits	2 bits	14 bits	16 bits	32 bits		16 bits
0..2	3	4	5..15	16..17	18..31	32..47	48..79	80..x-1	x..x+15
0 _h	1 _h	1 _h	680 _h (1)	3 _h	(2)	(3)		(4)	TC CRC

Data Field Header					
CCSDS Secondary Header Flag	TC Packet PUS Version Number	ACK	Packet Type	Packet Sub type	Spare
1 bit	3 bits	4 bits	8 bits	8 bits	8 bits
48	49..51	52..55	56..63	64..71	72..79
0	0	Table 10-1 . Acknowledgment	Service num	sub service num	0

Bit set	Acknowledgment	Sent TM if enabled	Field value (boot)	Field value (applicative)
0	The software shall acknowledge completion of execution	TM(1, 7)	1	8
1	The software shall acknowledge progress of execution	Not Used	Not Used	Not Used
2	The software shall acknowledge start of execution of the packet	TM(1,3)	4	2
3	The software shall acknowledge acceptance of the packet	TM(1,1)	8	1

Table 10-1 . Acknowledgment



(1): APID = 0x680 for nominal and redundant.

(2) Sequence count is divided in two fields:

- Source part (three most significant bits):
 - 000 = Ground, highest priority, all sources (maintained by ground)
 - 001 = Failure Detection, Isolation, and Recovery Telecommands (CDMU on-board)
 - 010 = Mission Time Line (maintained by ground, executed by CDMU)
 - 011 = On-board Control Procedures (executed by CDMU)
 - 100 = Ground, low priority, all sources (maintained by ground)
 - 101 = Failure Detection, Isolation, and Recovery Telecommands (ACC on-board)
 - 110 = CDMU, other sources on-board
 - 111 = ACMS, other sources on-board
- Sequence part (11 bits): actual sequence count.

(3) Number of octets in packet data field -1. Value is lower or equal to 241 octets

(4) Service specific. Size = N*16 bits

10.2.2. TM structure

Packet Header (48 bits)							Packet Data Field		
Packet ID				Packet Sequence Control		Packet Length	Data Field Header	Application Data	Packet Error Control
Version Number	Type	Data Field Header Flag	APID	Segmentation Flag	Source Sequence Count				
3 bits	1 bit	1 bit	11 bits	2 bits	14 bits	16 bits	80 bits		16 bits
0..2	3	4	5..15	16..17	18..31	32..47	48..127	128..y-1	y..y+15
0 _h	0 _h	(1)	(2)	3 _h	(3)	(4)		(5)	TM CRC

Data Field Header						
Spare	TM Source Packet PUS Version Number	Spare	Packet Type	Packet Sub type	Spare	Time
1 bit	3 bits	4 bits	8 bits	8 bits	8 bits	48 bits
48	49..51	52..55	56..63	64..71	72..79	80..127
0	0	0	service num	sub service num	0	(6)

(1) Data Field Header Flag is set to 1 for all packets except for idle and time packet where it is set to 0

(2) APID values: 0x680 (1664d) and 0x682 (1666d)

Instrument	↓ Telemetries	APID →	0x680	0x681	0x682	0x683
Nominal	All TM except TM(3,26)					
	TM(3,26)					
Redundant	All TM except TM(3,26)					
	TM(3,26)					

Figure 10-1: Boot Software APID

Instrument	↓ Telemetries	APID →	0x680	0x681	0x682	0x683
Nominal	All TM except TM(3,26) and TM(3,25) non essential					
	TM(3,26) and TM(3,25) non essential					



Redundant	All TM except TM(3,26) and TM(3,25) non essential			
	TM(3,26) and TM(3,25) non essential			

Table 10-2. Applicative software APID

- “non essential” packets are TM(3,25) sent in nominal operation. “essential” packets are TM(3, 25) sent in degraded operation.
 - “essential” packet TM(3,25) is not sent in boot mode.
- (3) Number of packet released by the software
 (4) Number of octets in packet data field -1. Value is lower or equal to 1017 octets
 (5) Service specific. Size = N*16 bits
 (6) Packet local on board time in CUC format.

10.3. TM/TC specific fields

10.3.1. TM(1,1): Telecommand Acceptance Report : Success

Packet Header	Data Field Header		Application Data	
Packet Length	Packet Type	Packet Sub type	Telecommand Packet ID	Packet Sequence Control
16 bits	8 bits	8 bits	16 bits	16 bits
32..47	56..63	64..71	128..143	144..159
15	1	1	Copy of the TC packet ID (range : 7808d)	Copy of the TC packet sequence control (range : 49152d to 65535d)

10.3.2. TM(1,2): Telecommand Acceptance Report : Failure

Packet Header	Data Field Header		Application Data		
Packet Length	Packet Type	Packet Sub type	Telecommand Packet ID	Packet Sequence Control	Failure Code
16 bits	8 bits	8 bits	16 bits	16 bits	16 bits
32..47	56..63	64..71	128..143	144..159	160..175
17	1	2	Copy of the TC packet ID	Copy of the TC packet sequence control	See Table 10-3. Failure codes

TC Failure Code	Designation	Notes
0	illegal APID	See PSICD
1	incomplete or invalid length packet	See PSICD
2	incorrect checksum	See PSICD
3	illegal packet type	See PSICD
4	illegal packet subtype	See PSICD
5	illegal or inconsistent application data	See PSICD
16	Bad Memory Load	Bad memory load following a TC(6,2)
17	Bad Memory Dump	Bad memory dump following a TC(6,5)



18	Bad Memory Check	Bad memory check following a TC(6,9)
19	Applicative software not loaded	The current telecommand can not be performed because the applicative software was not previously loaded to RAM
20	Incorrect packet header	Bad telecommand header
21	Transfer Layer Error	
22	Must wait completion of previous TC	The requested telecommand can not be performed now because another telecommand is currently running.

Table 10-3. Failure codes

10.3.3. TM(1,3): Telecommand Execution Report : Started

Packet Header	Data Field Header		Application Data	
Packet Length	Packet Type	Packet Sub type	Telecommand Packet ID	Packet Sequence Control
16 bits	8 bits	8 bits	16 bits	16 bits
32..47	56..63	64..71	128..143	144..159
15	1	3	Copy of the TC packet ID	Copy of the TC packet sequence control

10.3.4. TM(1,7): Telecommand Execution Report : Completed

Packet Header	Data Field Header		Application Data	
Packet Length	Packet Type	Packet Sub type	Telecommand Packet ID	Packet Sequence Control
16 bits	8 bits	8 bits	16 bits	16 bits
32..47	56..63	64..71	128..143	144..159
15	1	7	Copy of the TC packet ID	Copy of the TC packet sequence control

10.3.5. TM(1,8): Telecommand Execution Report : Failure

Packet Header	Data Field Header		Application Data		
Packet Length	Packet Type	Packet Sub type	Telecommand Packet ID	Packet Sequence Control	Failure Code
16 bits	8 bits	8 bits	16 bits	16 bits	16 bits
32..47	56..63	64..71	128..143	144..159	160..175
17	1	8	Copy of the TC packet ID	Copy of the TC packet sequence control	See Table 10-3. Failure codes



10.3.6. TM(3,25): Housekeeping Parameter Report

Packet Header	Data Field Header		Application Data	
Packet Length	Packet Type	Packet Sub type	SID	Parameters
16 bits	8 bits	8 bits	16 bits	16 bits*x
32..47	56..63	64..71	128..143	144..SID dependant
17			1	See Figure 10-2: boot software housekeeping table
169	3	25	2	See Table 10-4. Applicative software 'non essential' packet housekeeping table
169			3	See Table 10-5. Applicative software 'essential' packet housekeeping table

			SCOS 2K Specific		
Bit size	Designation	Value	Range	Byte Offset	Type
16 bits	SID	1		0	
16 bits	Operating mode status	See Table 10-6	0d→2047d	2	OBSW (530)
16 bits	Faults status OBSW	See Table 10-7	0d→65535d	4	OBSW (530)

Figure 10-2: boot software housekeeping table

This packet is sent once a second during the execution of the boot software

			SCOS 2K Specific			
Bit size	Designation	Value	Refreshed in (1)	Range	Byte Offset	Type
16 bits	SID	2			0	
16 bits	Operating mode status	See Table 10-6	All modes	0d→2047d	2	OBSW (530)
16 bits	Faults status OBSW	See Table 10-7	All modes	0d→65535d	4	OBSW (530)
16 bits	Faults status SCE	See Table 10-8	All ASW modes	0→63d	6	SCE (540)
16 bits *5	Device status	See Table 10-9	All ASW modes	Wd0: 0→65535d Wd1: 0→4095d Wd2: 0→65535d Wd3: 0→16383d Wd4: 0→255d	8	SCE (540)
16 bits	Beds status MSB	See Table 10-10	Run mode	0→32767d	18	SCE (540)
16 bits	Beds status LSB	See Table 10-10	Run mode	0→511d	20	SCE (540)
16 bits*2	Fixed heaters activity	See Table 10-11	Ready + Run mode	Wd0: 0→32767d Wd1: 0→3	22	SCE (540)
16 bits*9	Variable heaters values	H11 (word 0), H12(word 1)...H16, H7, H31, H32 (word 8)	Ready + Run mode	All Words 0→65535d	26	SCE (540)



4	ADC redundant Out Of Range (ASW only)	12	Electronics Over Temperature limit 2 (ASW only)
5	12 Volts Error (ASW only)	13	Lookup Table Load Error
6	28 Volts Error (ASW only)	14	Lookup Table Bad Content
7	Eeprom Write Error	15	Lookup Table Bad Address

Table 10-7. Faults status OBSW (on board software)

Note:

- Bit=0 → No Error. Bit=1 → Error.
- Several values can be set at the same time.

Word Bits	Error	Word Bits	Error
0	Normal Fault		
1	Bed Over Temperature		
2	Bed Over Pressure		
3	LPSB Over Temperature		
4	FPGA error		
5	Error Internal		

Table 10-8. Faults status SCE

Note:

- Bit=0 → No Error. Bit=1 → Error
- Several values can be set at the same time.

Bit	Device	Bit	Device	Bit	Device	Bit	Device	Bit	Device	Bit	Device
0	ADC 0	8	H21	0	H34	8	H16	0	T1	8	T9
1	ADC 1	9	H22	1	H35	9	H7	1	T2	9	T10
2	H1	10	H23	2	H36	10	H31	2	T3	10	T11
3	H2	11	H24	3	H11	11	H32	3	T4	11	T12
4	H3	12	H25	4	H12	12		4	T5	12	T13
5	H4	13	H26	5	H13	13		5	T6	13	T14
6	H5	14	H8	6	H14	14		6	T7	14	T15
7	H6	15	H33	7	H15	15		7	T8	15	T16

Bit	Device	Bit	Device	Bit	Device	Bit	Device
0	T17	8	T26	0	P1	8	
1	T18	9	T27	1	P2	9	
2	T20	10	T28	2	P3	10	
3	T21	11	T29	3	P4	11	
4	T22	12	T30	4	P5	12	
5	T23	13		5	P6	13	
6	T24	14		6	P7	14	
7	T25	15		7	P8	15	

Table 10-9. Devices status (5 words word 0 → word 1 → word 2 ↓→word 3 → word 4)

Note:

- Bit=0 → No Error. Bit=1 → Error
- Several values can be set at the same time.



bit	Bed number	bit	Bed number	bit	Bed number	Bit	Bed number
0	Bed 0	8	Bed 3	0	Bed 5	8	Bed 5 Norm
1		9		1		9	
2		10		2		10	
3	Bed 1	11	Bed 4	3	Bed 0 Norm	11	
4		12		4	Bed 1 Norm	12	
5		13		5	Bed 2 Norm	13	
6	Bed 2	14		6	Bed 3 Norm	14	
7		15		7	Bed 4 Norm	15	

Table 10-10. Bed status (2 words word 0 → word 1)

- “**Bed i**” state values are: 0: off - 1: heatup - 2: desorb - 3: cool - 4: absorb1 – 5:absorb2 – 6:absorb3
- “**Bed i Norm**” values are: 1: normal mode only on. 0: normal mode only off

15	14	13	12	11	10	9	8	7	6	5	4	3	2	1	0
	H34	H33	H8	H26	H25	H24	H23	H22	H21	H6	H5	H4	H3	H2	H1

15	14	13	12	11	10	9	8	7	6	5	4	3	2	1	0
														H35	H36

Table 10-11. Fixed heaters activity (first table is word 0, second table is word 1)

Note:

- If the bit ‘n’ equal to 1, the corresponding heater is active else inactive.
- Several values can be set at the same time

Word number	Sensor	Word number	Sensor	Word number	Sensor	Word number	Sensor
0	T1or T2	8	T12	16	T21	24	T29
1	T3 or T4	9	T13	17	T22		
2	T5 or T6	10	T14	18	T23		
3	T7 or T30	11	T15	19	T24		
4	T8	12	T16	20	T25		
5	T9	13	T17	21	T26		
6	T10	14	T18	22	T27		
7	T11	15	T20	23	T28		

Table 10-12. Temperature sensors



10.3.7. TM(3,26): Diagnostic Parameter Report

Packet Header	Data Field Header		Application Data	
Packet Length	Packet Type	Packet Sub type	SID	Parameters
16 bits	8 bits	8 bits	16 bits	16 bits
32..47	56..63	64..71	128..143	144.. <i>SID dependant</i>
599	3	26	1	See Table 10-13. Parameters for boot diagnostic table
337			2	See Table 10-16. Parameters for applicative diagnostic table
19			3	See Table 10-17. Parameters for health check tests table
			4	See Table 10-20. Parameters for regeneration

Bit size	Parameters	Value	SCOS 2K Specific		
			Range	Byte Offset	Type
16 bits	SID	1		0	
16 bits	Diagnostic 1553	See Table 10-14	0→63d	2	OBSW (530)
16 bits	Diagnostic FPGA	See Table 10-15	0→511d	4	
16 bits	Diagnostic PM Prom	See (5)	0→1d	6	
128 words of 16 bits	Diagnostic PM Ram Word 0 (PM RAM from 0 to 0x3F) (1 word = 16 blocs) - See (3)	See (2)	Each word 0→65535d	8	
	Diagnostic PM Ram Word 1 (PM RAM from 0x40 to 0x7F) (1 word = 16 blocs) - See (3)			...	
	
	Diagnostic PM Ram Word 127 (1 word = 16 blocs) - See (3)			...	
32 words of 16 bits	PM RAM bad address #0 MSB	See (1)	Each word 0→65535d	264	
	PM RAM bad address #0 LSB			...	
	
	PM RAM bad address #15 MSB			...	
16 bits	Diagnostic DM RAM	See (1)	0→3d	328	
128 words of 16 bits	Diagnostic DM EEPROM Word 0 (DM EEPROM from 0 to 0xff) (1 word = 16 blocs) - See (4)	See (2)	Each word 0→65535d	330	
	
16 bits	Diagnostic DM EEPROM Word 127 (1 word = 16 blocs) - See (4)			...	
16 bits	Transfer ASW result	See (5)	0→1	586	

Table 10-13. Parameters for boot diagnostic table

This diagnostic is sent once after hardware tests or transfer application EEPROM to RAM



Notes:

- (1) Only first two bits are representative:
- Bit 0: write/read test result 0=no error 1=error.
 - Bit 1: Data restoration status 0=restore successful 1=restore error.
- (2) Bits field. Several bits can be set. 0=no error on block. 1=error on block
- (3) PM RAM: 1 block equals to 64 words of 48 bits PM RAM memory.
- (4) DM EEPROM: 1 block equals to 256 words of 32 bits DM EEPROM memory.
- (5) Only first bit is representative : 0 no error, 1 error.

Bit	Test Description	
	1553 Register	Expected Value
0	Read Initial value of registers 0 to 4	0
1	Write 0x5554 to registers 0 to 4 and read after	≠0 for registers 0,1,2,4 and 0 for register 3
2	Write 1 to registers 0 to 4 and read after	0
3	Write 0xaaaa to entire 1553 RAM memory (16k) and reread	0xaaaa on the entire RAM memory
4	Write 0x5555 to entire 1553 RAM memory (16k) and reread	0x5555 on the entire RAM memory
5	Write 0 to entire 1553 RAM memory (16k) and reread	0 on the entire RAM memory
6..15		

Table 10-14. 1553 Diagnostic Word

Note:

- Bit=0 → No Error. Bit=1 → Error
- Several values can be set at the same time.

Bit	Test Description		Bit	Test Description	
	FPGA Register	Expected Value		FPGA Register	Expected Value
0	0x40020000	0	8	0x40020008	0xA5AA5A5
1	0x40020001	0	9	0x4002000A	0
2	0x40020002	0	10	0x4002000B	0
3	0x40020003	0x1FF0000	11	0x4002000E	0
4	0x40020004	0	12	0x4002000F	0
5	0x40020005	0x640000	13	0x40040000	0
6	0x40020006	0x640000	14	0x40040001	0
7	0x40020007	0	15	0x40040002	0

Table 10-15. FPGA diagnostic word

Note:

- Bit=0 → No Error. Bit=1 → Error
- Several values can be set at the same time.

Bit size	Parameters	Value	SCOS 2K Specific		
			Range	Byte Offset	Type
16 bits	SID	2		0	
16 bits	Diagnostic PM Prom	See (1)	0→1d	2	OBSW (530)
128 words of 16 bits	Diagnostic DM EEPROM word 0 (DM EEPROM from 0 to 0xff)	See (3)	Each word 0→65535d	4	
	Diagnostic DM EEPROM word 127			...	
16 bits	Diagnostic external timers	bit 0:timer1... bit 8:timer9 bit9:fpga timer. See (2)	0→1023d	260	

Table 10-16. Parameters for applicative diagnostic table

Notes:



- (1) Only first bit is representative: 0 no error, 1 error.
- (2) Bits field. Several bits can be set. 0=no error on block. 1=error on block
- (3) DM EEPROM: 1 block equals to 256 words of 32 bits DM EEPROM memory

This diagnostic is sent only one time after the check Eeprom or check Prom or check external timers command in applicative software

IMPORTANT

For SCS-R unit has been reported an error in EEPROM#1. This EEPROM section should not be used for any SCS memory operations. However, since no OBSW or data is stored in such memory area this has no impact on functionality of SCS-R.

Bit size	Designation	Value	SCOS 2K Specific		
			Range	Byte Offset	Type
16 bits	SID	3		0	
16 bits	Current Health check test number	See Table 10-18	0→29d	2	OBSW (530)
16 bits	Health check test status LSB	See Table 10-19	0→65535d	4	
16 bits	Health check test status MSB	See Table 10-19	0→8191d	6	

Table 10-17. Parameters for health check tests table

This diagnostic is sent once a second during the execution of the Healthcheck procedure

Test Number	Test	Test Number	Test	Test Number	Test
0	None	11	Bed 3Gas Gap Test	22	Bed 1 Min Power Test
1	Sustain Heater Test	12	Bed 4 Max Power Test	23	Bed 1 Gas Gap Test
2	Startup Heater Test	13	Bed 4 Min Power Test	24	JT H34 Heater Test
3	Bed 1 Max Power Test	14	Bed 4 Gas Gap Test	25	JT H35 Heater Test
4	Bed 1 Min Power Test	15	Bed 5 Max Power Test	26	PF H33 Heater Test
5	Bed 1Gas Gap Test	16	Bed 5 Min Power Test	27	PF H36 Heater Test
6	Bed 2 Max Power Test	17	Bed 5 Gas Gap Test	28	LR3 H31 Heater Test
7	Bed 2 Min Power Test	18	Bed 6 Max Power Test	29	LR3 H32 Heater Test
8	Bed 2Gas Gap Test	19	Bed 6 Min Power Test		
9	Bed 3 Max Power Test	20	Bed 6 Gas Gap Test		
10	Bed 3 Min Power Test	21	Bed 1 Max Power Test		

Table 10-18. Current health check test number

Bit	Test number	bit	Test number	bit	Test number	bit	Test number
0	Test 1	8	Test 9	0	Test 17	8	Test 25
1	Test 2	9	Test 10	1	Test 18	9	Test 26
2	Test 3	10	Test 11	2	Test 19	10	Test 27
3	Test 4	11	Test 12	3	Test 20	11	Test 28
4	Test 5	12	Test 13	4	Test 21	12	Test 29
5	Test 6	13	Test 14	5	Test 22	13	
6	Test 7	14	Test 15	6	Test 23	14	
7	Test 8	15	Test 16	7	Test 24	15	

Table 10-19. Health check test status (2 words word 0 (LSB) → word 1 (MSB))

Note:

- Bit=0 → No Error. Bit=1 → Error
- Several values can be set at the same time.



Bit size	Designation	Value	SCOS 2K Specific		
			Range	Byte Offset	Type
16 bits	SID	4		0	
16 bits	Current Regeneration step	See Table 10-21	0→31d	2	OBSW (530)
16 bits	Regeneration process status LSB	See Table 10-22	0→65535d	4	
16 bits	Regeneration process status MSB	See Table 10-22	0→32767d	6	OBSW (530) 15

Table 10-20. Parameters for regeneration

This diagnostic is sent once a second during the execution of the regeneration procedure

Num	Process	Num	Process	Num	Process
0	None	13	See 'num 3' for bed 3	26	See 'num 6' for bed 5
1	Waiting for HPST P<MAX_REGEN_PRESSURE	14	See 'num 4' for bed 3	27	See 'num 2' for bed 6
2	Bed 1 Heat to Gag Gap On T	15	See 'num 5' for bed 3	28	See 'num 3' for bed 6
3	Bed 1 Wait P_HPST returns to Regeneration P	16	See 'num 6' for bed 3	29	See 'num 4' for bed 6
4	Bed 1 Heat to Regeneration T	17	See 'num 2' for bed 4	30	See 'num 5' for bed 6
5	Bed 1 regeneration	18	See 'num 3' for bed 4	31	See 'num 6' for bed 6
6	Bed 1 cool	19	See 'num 4' for bed 4		
7	See 'num 2' for bed 2	20	See 'num 5' for bed 4		
8	See 'num 3' for bed 2	21	See 'num 6' for bed 4		
9	See 'num 4' for bed 2	22	See 'num 2' for bed 5		
10	See 'num 5' for bed 2	23	See 'num 3' for bed 5		
11	See 'num 6' for bed 2	24	See 'num 4' for bed 5		
12	See 'num 2' for bed 3	25	See 'num 5' for bed 5		

Table 10-21. Regeneration process list

Bit	Process number	bit	Process number	bit	Process number	bit	Process number
0	Process 1	8	Process 9	0	Process 17	8	Process 25
1	Process 2	9	Process 10	1	Process 18	9	Process 26
2	Process 3	10	Process 11	2	Process 19	10	Process 27
3	Process 4	11	Process 12	3	Process 20	11	Process 28
4	Process 5	12	Process 13	4	Process 21	12	Process 29
5	Process 6	13	Process 14	5	Process 22	13	Process 30
6	Process 7	14	Process 15	6	Process 23	14	Process 31
7	Process 8	15	Process 16	7	Process 24	15	

Table 10-22. Regeneration status word (2 words word 0 (LSB) → word 1 (MSB))

Note:

- Bit=0 → No Error. Bit=1 → Error
- Several values can be set at the same time.



10.3.8. TM(5,1): Event Report

Packet Header	Data Field Header		Application Data			
Packet Length	Packet Type	Packet Sub type	Event ID	SID	Parameter A	Event Sequence Counter
16 bits	8 bits	8 bits	16 bits	16 bits	64 bits	16 bits
32..47	56..63	64..71	128..143	144..159	160..223	224..239
25	5	1	See Table 10-23 Range: 1 to 11	See Table 10-23 Range: 0	See Table 10-23 Range: 0	Number of TM(5,1) sent Range: 0 to 65535

Event ID	Description	Report type	Satellite action
4	Boot mode entered	Event	Switch off 2nd power line (1)
2	Init mode entered	Event	Switch off 2nd (20A) power line (2)
3	Ready mode (Health monitor) entered	Event	Switch on 2nd (20A) power line (3)
4	Ready mode (Health Check) entered	Event	None
5	Ready mode (Regeneration) entered	Event	None
6	Run mode (startup) entered	Event	None
7	Run mode (defrost) entered	Event	None
8	Run mode (normal) entered	Event	None
9	Shutdown mode entered	Event	Switch off 2nd power line (20A)
10 (4)	Bed number change	Exception	None
11	Switch Off	Error	Switch off both (20A & 5A) power lines

Table 10-23

Notes:

- (1) **BOOT SW does not generate TM(5). In case of transition to BOOT Mode (or from BOOT to INIT) no event will be generated, so no CDMS action can be triggered. Anyway, when entering BOOT from INIT the SCE loses communication with the S/C: this triggers a DLL OBCP that includes a 2nd power line (20A) switch OFF.**
- (2) **This event (ID=2) is generated only when transitioning to INIT from other Modes than BOOT. BOOT to INIT transition does NOT generate TM(5,1,ID=2) event. The CDMS will be asked to switch OFF 2nd power line for each transition to INIT (except from BOOT)**
- (3) *The satellite will switch on 2nd power line (20A) in all case, even when transition from run to ready (where it is not necessary as the power line is already on).*
- (4) *This event is sent only if a bed was autonomously detected as bad. Then, the following cases will not be reported thanks to this event:*
 - Bed removal / insertion by command
 - Bed removal / insertion by transition startup → normal and normal → startup.
 - Bed Removal from other FDIR action (different of bad bed detection).



10.3.9. TM(5,2): Exception Report

Packet Header	Data Field Header		Application Data			
Packet Length	Packet Type	Packet Sub type	Event ID	SID	Parameter A	Event Sequence Counter
16 bits	8 bits	8 bits	16 bits	16 bits	64 bits	16 bits
32..47	56..63	64..71	128..143	144..159	160..223	224..239
25	5	2	See Table 10-23	See Table 10-23	See Table 10-23	Number of TM(5,2) sent

10.3.10. TM(5,4): Error Report

Packet Header	Data Field Header		Application Data			
Packet Length	Packet Type	Packet Sub type	Event ID	SID	Parameter A	Event Sequence Counter
16 bits	8 bits	8 bits	16 bits	16 bits	64 bits	16 bits
32..47	56..63	64..71	128..143	144..159	160..223	224..239
25	5	4	See Table 10-23	See Table 10-23	See Table 10-23	Number of TM(5,4) sent



10.3.11. TC(6,2): Load Memory Using Absolute Address

IMPORTANT

For SCS-R unit has been reported an error in EEPROM#1. This EEPROM section should not be used for any SCS memory operations. However, since no OBSW or data is stored in such memory area this has no impact on functionality of SCS-R.

The maximum size of memory load commands allowed is 50 SAUs. Bigger size uploads lead to failure of SCS to accept command and eventual switch-off of SCS by OBCP from 1553 FDIR on TFh TC = SCS RT \"SICK TC\".

TC memory upload rate of 1 Hz (one TC per second) is ok.

Packet Header	Data Field Header		Application Data					
	Packet Length	Packet Type	Packet Sub type	Memory ID	Start address	Spare	Length	Data
16 bits	8 bits	8 bits	16 bits	16 bits	8 bits	8 bits	N*16 bits	16 bits
32..47	56..63	64..71	80..95	96..111	112..119	120..127	128..x-1	x..x+15
13+N*2	6	2	Defines the memory block. See Table 10-24. Memory id list	Start address within the memory block (unit SAU)	0	Number of SAU to be loaded. See Table 10-24	Data to be loaded (SAU)	CRC checksum of the data to be loaded

Memory ID	Memory addressed	SAU
0x9000	BOOT: PM PROM address 0 to 7fff ASW: PM RAM address 0 to 0xffff for asw	48 bits
0x9001	ASW : PM RAM address 0x10000 to 0x1ffff	48 bits
0x9080	BOOT: PM RAM address 0x800000 to 0x80ffff ASW: PM PROM address 0x800000 to 0x807fff	48 bits
0x9081	BOOT: PM RAM address 0x810000 to 0x81ffff	48 bits
0x0	DM RAM address 0 to 0xffff	32 bits
0x1	DM RAM address 0x10000 to 0x1ffff	32 bits
0x2000	DM 1553 address 0x20000000 to 0x2000001f and 0x20004000 to 0x20007fff	32 bits
0x4000	DM External Timers 0x40000000 to 0x4000000b	32 bits
0x4002	DM FPGA address 0x40020000 to 0x4002000f	32 bits



0x4004	DM FPGA address 0x40040000 to 0x40040002	32 bits
0x8000	DM EEPROM address 0x80000000 to 0x8000ffff	32 bits
0x8001	DM EEPROM address 0x80010000 to 0x8001ffff	32 bits
0x8002	DM EEPROM address 0x80020000 to 0x8002ffff	32 bits
0x8003	DM EEPROM address 0x80030000 to 0x8003ffff	32 bits
0x8004	DM EEPROM address 0x80040000 to 0x8004ffff	32 bits
0x8005	DM EEPROM address 0x80050000 to 0x8005ffff	32 bits
0x8006	DM EEPROM address 0x80060000 to 0x8006ffff	32 bits
0x8007	DM EEPROM address 0x80070000 to 0x8007ffff	32 bits

Table 10-24. Memory id list

Note: due to the 'read only' state of the PROM memory,

- Boot software: TC(6, 2) is not available for memory ID = 0x9000 and memory ID = 0x9001
- Applicative software: TC(6, 2) is not available for memory ID = 0x9080 and memory ID = 0x9081

Memory Type	Access Type	Addresses
PM PROM	dump – check	Boot software: 0x0 to 0x7fff. Applicative : 0x800000 to 0x807fff
PM RAM	load – dump – check	Boot software: 0x800000 to 0x81ffff. Applicative software: 0x0 to 0x1ffff
DM RAM	load – dump – check	0x0 to 0x1ffff
DM 1553	load – dump - check	0x20000000 to 0x2000001f and 0x20004000 to 0x20007fff
DM TIMERS	load – dump – check	0x40000000 to 0x4000000b
DM FPGA	load – dump – check	0x40020000 to 0x4002000f and 0x40040000 to 0x40040002
DM EEPROM 1	load – dump – check	0x80000000 to 0x8003ffff
DM EEPROM N	load – dump – check	0x80040000 to 0x8007ffff

Table 10-25. Accessible memory areas

10.3.12. TC(6,5): Dump Memory Using Absolute Address

Packet Header		Data Field Header		Application Data	
Packet Length	Packet Type	Packet Sub type	Memory ID	Start address	Length
16 bits	8 bits	8 bits	16 bits	16 bits	16 bits
32..47	56..63	64..71	80..95	96..111	112..127
11	6	5	Defines the memory block. See Table 10-24. Memory id list	Start address within the memory block (unit SAU)	Number of SAU to be dumped



10.3.13. TC(6,9): Check Memory Using Absolute Address

Packet Header	Data Field Header		Application Data		
Packet Length	Packet Type	Packet Sub type	Memory ID	Start address	Length
16 bits	8 bits	8 bits	16 bits	16 bits	16 bits
32..47	56..63	64..71	80..95	96..111	112..127
11	6	9	Defines the memory block. See Table 10-24. Memory id list	Start address within the memory block (unit SAU)	Number of SAU to be dumped

10.3.14. TM(6,6): Memory Dump Absolute address

Packet Header	Data Field Header		Application Data				
Packet Length	Packet Type	Packet Sub type	Memory ID	Start address	Length	Data	Checksum
16 bits	8 bits	8 bits	16 bits	16 bits	16 bits	N*16 bits	16 bits
32..47	56..63	64..71	128..143	144..159	160..175	176..x-1	x..x+15
19+N*2	6	6	Defines the memory block. See Table 10-24. Memory id list <i>Range: 0 to 1; 8192d; 16384d; 16386d, 16388d; 32768d to 32775d; 36864d;36865d; 36992d to 36993d</i>	Start address within the memory block (unit SAU) <i>Range: 0 to 65535d</i>	Number of SAU dumped <i>Range: 0 to 65535d</i>	Data dumped (SAU) <i>Range: 0 to 65535d</i>	CRC checksum of the data dumped <i>Range: 0 to 65535d</i>

Note: One or more TM(6, 6) can be generated in response of one TC(6,5) (in the case of TC(6, 5) request a memory dump size higher than one telemetry size, several TM(6, 6) will be generated).

10.3.15. TM(6,10): Memory Check Report Absolute address

Packet Header	Data Field Header		Application Data			
Packet Length	Packet Type	Packet Sub type	Memory ID	Start address	Length	Checksum
16 bits	8 bits	8 bits	16 bits	16 bits	16 bits	16 bits
32..47	56..63	64..71	128..143	144..159	160..175	176..191
19	6	9	Defines the memory block. See Table 10-24. Memory id list	Start address within the memory block (unit SAU)	Number of SAU checked	CRC checksum of the data checked



10.3.16. TC(8,4): Perform Activity of Function

Packet Header	Data Field Header		Application Data			
Packet Length	Packet Type	Packet Sub type	Function ID	Activity ID	SID	Parameters
16 bits	8 bits	8 bits	8 bits	8 bits	16 bits	n*16 bits
32..47	56..63	64..71	80..87	88..95	96..111	
9 for all except 11 for function id 3, 4 and 5	8	4	Table 10-26	Table 10-26	Table 10-26	Table 10-26

Func ID	Act ID	SID	Parameters	Designation	Verification (execution, completion...)	Soft (can be launched from...)
0	0	0		Transfer applicative software	TM(3,25) TM(3,26)	Boot (boot)
1	0	0		Test PM RAM	TM(3,25) TM(3,26)	Boot (boot)
1	1	0		Test DM RAM	TM(3,25) TM(3,26)	Boot (boot)
1	2	0		Test PM PROM	TM(3,25) TM(3,26)	Boot/Asw (boot – init)
1	3	0		Test DM EEPROM	TM(3,25) TM(3,26)	Boot/Asw (boot – init)
2	0	0		Go to Boot	TM(3,25)	Boot/Asw (boot – init)
2	1	0		Go to Init	TM(3,25)	Boot/Asw (boot – init – all ready)
2	2	0		Go to Ready (Health Monitor)	TM(3,25)	Asw (all asw modes)
2	3	0		Go to Ready (Health Check)	TM(3,25) TM(3,26)	Asw (Health Monitor)
2	4	0		Go to Ready (Regeneration)	TM(3,25) TM(3,26)	Asw (Health Monitor)
2	5	0		Go to Run (Startup)	TM(3,25)	Asw (Health Monitor – all run)
2	6	0		Go to Run (Defrost)	TM(3,25)	Asw (startup)
2	7	0		Go to Run (Normal)	TM(3,25)	Asw (startup)
2	8	0		Go to Shutdown	TM(3,25)	Asw (all ready – all run)
3	0	1	Parameter size = 16 bits Bits 0..2: Heatup bed position from 0 to 5 Bit 3..15: not used (values neither used nor tested)	Set Initial Heatup Bed Position		Asw (all asw modes)
3	1	0		Return to initial beds states (bed 0=Heatup, bed 1=Desorb, bed	TM(3,25)	Asw (all asw modes)



				2=Cooldown, bed 3, bed 4, bed 5=Absorb)		
4	0	1	Parameter size = 16 bits Bits 0..3: Bed number (from 0 to 5) Bit 4..5: Bed State : 0 →Bad Bed 1→NORMAL MODE ONLY 2 or 3 → Good bed Bit 6..15: not used (values neither used nor tested)	Set Bed State		Asw (all asw modes)
5	0	1	Parameter size = 16 bits Bit 0..11: Device Number see Table 10-27 Bit 12..15: Device State : 1 to set bad device. 0 to set good device	Set Device State		Asw (all asw modes)
6	0	0		Stop Process (applicative software transfer, memory access)		Boot/Asw

Table 10-26. List of functions

Device	Value	Device	Value	Device	Value	Device	Value	Device	Value	Device	Value
ADC 0	0	H24	0xb	H14	0x16	T6	0x105	T17	0x110	T29	0x11b
ADC 1	1	H25	0xc	H15	0x17	T7	0x106	T18	0x111	T30	0x11c
H1	2	H26	0xd	H16	0x18	T8	0x107	T20	0x112	P1	0x200
H2	3	H8	0xe	H7	0x19	T9	0x108	T21	0x113	P2	0x201
H3	4	H33	0xf	H31	0x1a	T10	0x109	T22	0x114	P3	0x202
H4	5	H34	0x10	H32	0x1b	T11	0x10a	T23	0x115	P4	0x203
H5	6	H35	0x11	T1	0x100	T12	0x10b	T24	0x116	P5	0x204
H6	7	H36	0x12	T2	0x101	T13	0x10c	T25	0x117	P6	0x205
H21	8	H11	0x13	T3	0x102	T14	0x10d	T26	0x118	P7	0x206
H22	9	H12	0x14	T4	0x103	T15	0x10e	T27	0x119	P8	0x207
H23	0xa	H13	0x15	T5	0x104	T16	0x10f	T28	0x11a		

Table 10-27. Devices list

Note:

- Devices from 0x000 to 0x0ff are heaters and ADC.
- Devices from 0x100 to 0x1ff are temperature sensors
- Devices from 0x200 to 0x2ff are pressure sensors



10.3.17. TC(9,4): Enable Time Synchronization

Packet Header	Data Field Header	
Packet Length	Packet Type	Packet Sub type
16 bits	8 bits	8 bits
32..47	56..63	64..71
5	9	4

10.3.18. TC(9,5): Time Code

Packet Header	Data Field Header		Application Data
Packet Length	Packet Type	Packet Sub type	Time
16 bits	8 bits	8 bits	48 bits
32..47	56..63	64..71	80..127
11	9	5	Time used to synchronize

10.3.19. TC(9,7): Enable Time Verification

Packet Header	Data Field Header	
Packet Length	Packet Type	Packet Sub type
16 bits	8 bits	8 bits
32..47	56..63	64..71
5	9	7

10.3.20. TM(9,9): Time Verification Report

Packet Header	Data Field Header		Application Data
Packet Length	Packet Type	Packet Sub type	
16 bits	8 bits	8 bits	48 bits
32..47	56..63	64..71	72..119
17	9	9	Copy of the central time reference



10.3.21. TC(14,1): Enable Generation of telemetry Packets

Packet Header	Data Field Header		Application Data			
Packet Length	Packet Type	Packet Sub type	N	Type	Sub Type	Packet-ID
16 bits	8 bits	8 bits	16 bits	8 bits	8 bits	16 bits
32..47	56..63	64..71	80..95	96..103	104..111	112..127
7+N*4	14	1	Number of TM packets definition that follow	TM packet service type	TM Packet service subtype	See note below

← N times →

Note packet-ID:

- When packet-Id is zero, the whole family (packet type/subtype) is enabled.
- For housekeeping and diagnostic service 3, packet-ID is equal to HK packet-ID defined for that service
- For Event reporting service 5, packet-Id is equal to event-ID defined for that service

10.3.22. TC(14,2): Disable Generation of telemetry Packets

Packet Header	Data Field Header		Application Data			
Packet Length	Packet Type	Packet Sub type	N	Type	Sub Type	Packet-ID
16 bits	8 bits	8 bits	16 bits	8 bits	8 bits	16 bits
32..47	56..63	64..71	80..95	96..103	104..111	112..127
7+N*4	14	2	Number of TM packets definition that follow	TM packet service type	TM Packet service subtype	See note TC(14,1)

← N times →

10.3.23. TC(14,3): Report Enabled Telemetry Packets

Packet Header	Data Field Header	
Packet Length	Packet Type	Packet Sub type
16 bits	8 bits	8 bits
32..47	56..63	64..71
5	14	3



10.4. TC responses

- For all telecommands, a **TM(1,1)** will be reported at the beginning of execution if TC ack field "The software shall acknowledge acceptance of the packet" is set.

- For all telecommands, a **TM(1,3)** will be reported at the beginning of execution (eventually after a TM(1,1)) if TC ack field "The software shall acknowledge start of execution of the packet" is set.

- For all telecommands, a **TM(1,2)** will be reported for the following cases (it means that the telecommand was even not been started because there was a problem in its structure)

1. Calculated telecommand checksum differs with checksum provided by the telecommand (last field)
2. Calculated telecommand data field length differs with the "packet length" field provided by the telecommand.
3. "APID" field provided by the telecommand is wrong ($\neq 0x680$)
4. "Version number" field is bad ($\neq 0$)
5. "Type" field is bad ($\neq 1$)
6. "Data Field Header Flag" is bad ($\neq 1$)
7. "Sequence Flags" field is bad ($\neq 3$)
8. "CCSDS secondary header flag" field is bad ($\neq 0$)
9. "PUS version number" field is bad ($\neq 0$)
10. "Spare" field is bad ($\neq 0$)
11. "Type" "Sub Type" fields do not correspond to a recognized telecommand.

All other cases are telecommand dependant. The table below shows the expected telemetries in response to the specified telecommand.

- Several telecommands (described below) may report a **TM(1,7)** at the end of the execution if TC ack field "The software shall acknowledge completion of execution" is set.

TC	Fct ID Act ID SID	TM(s) Answer
TC(6, 2)	none	<ol style="list-style-type: none"> 1. If another process (TC(6,x) or hardware test or applicative software transfer) is currently running a TM(1,8) with the failure code "Must wait completion of previous TC" will be sent. 2. If memory zone and size is incorrect a TM(1,8) with the failure code "illegal application data" will be sent. 3. If the checksum of the data to be loaded \neq checksum provided by the telecommand a TM(1,8) with the failure code "illegal application data" will be sent. 4. For all other cases, a TM(1,1) and / or TM(1,3) will be sent : the load operation is starting. 5. At the completion of the load operation, if it was successfully terminated, a TM(1,7) will be sent, else a TM(1,8) will be sent.
TC(6, 5)	none	<ol style="list-style-type: none"> 1. If another process (TC(6,x) or hardware test or applicative software transfer) is currently running a TM(1,8) with the failure code "Must wait completion of previous TC" will be sent. 2. If memory zone and size is incorrect a TM(1,8) with the failure code "illegal application data" will be sent.



		<ol style="list-style-type: none"> For all other cases, a TM(1,1) and / or TM(1,3) will be sent : the dump operation is starting. One or more (depending on the dump size requested by the telecommand) TM(6,6) will be reported containing the dumped data. At the completion of the dump operation, if it was successfully terminated, a TM(1,7) will be sent, else a TM(1,8) will be sent.
TC(6, 9)	none	<ol style="list-style-type: none"> If another process (TC(6,x) or hardware test or applicative software transfer) is currently running a TM(1,8) with the failure code "Must wait completion of previous TC" will be sent. If memory zone and size is incorrect a TM(1,8) with the failure code "illegal application data" will be sent. For all other cases, a TM(1,1) and / or TM(1,3) will be sent : the check operation is starting. One TM(6,10) will be reported containing the checksum value of the data read. At the completion of the check operation, if it was successfully terminated, a TM(1,7) will be sent, else a TM(1,8) will be sent.
TC(8, 4)	000	<p>"Transfer Applicative Software"</p> <ol style="list-style-type: none"> If this telecommand is not available in the current operating mode, a TM(1,2) with the failure code "illegal application data" will be sent. If another process (TC(6,x) or hardware test or applicative software transfer) is currently running a TM(1,2) with the failure code "Must wait completion of previous TC" will be sent. For all other cases, a TM(1,1) and / or TM(1,3) will be reported at the beginning of the software transfer, then a TM(3,26) will be sent at the completion of the software transfer (a status is available in the generated TM(3,26)). During the execution, the periodic TM(3,25) will report the status of the execution on the 'operating mode status' (indicating the current process 'transfer applicative software' and 'applicative software transferred or not').
TC(8, 4)	100	<p>"Test PM RAM"</p> <ol style="list-style-type: none"> If this telecommand is not available in the current operating mode, a TM(1,2) with the failure code "illegal application data" will be sent. If another process (TC(6,x) or hardware test or applicative software transfer) is currently running a TM(1,2) with the failure code "Must wait completion of previous TC" will be sent. For all other cases, a TM(1,1) and / or TM(1,3) will be reported at the beginning of the test, then a TM(3,26) will be sent at the completion of the test (a status is available in the generated TM(3,26)). During the execution, the periodic TM(3,25) will report the status of the execution on the 'operating mode status' (indicating the current process 'hardware test')
TC(8, 4)	110	<p>"Test DM RAM"</p> <p>Same telemetries as TC(8,4) "Test PM RAM" except that no TM(3,25) is sent during the execution (so no report in 'operating mode status')</p>
TC(8, 4)	120	<p>"Test PM PROM"</p> <p>Same telemetries as TC(8,4) "Test PM RAM"</p>
TC(8, 4)	130	<p>"Test DM EEPROM"</p> <p>Same telemetries as TC(8,4) "Test PM RAM"</p>
TC(8, 4)	200	<p>"Go to Boot"</p> <ol style="list-style-type: none"> If this telecommand is not available in the current operating mode, a TM(1,2) with the failure code "illegal application data" will be sent. For all other cases, a TM(1,1) and / or TM(1,3) will be reported at the beginning of the mode change, then an event TM(5,1) "boot mode entered" will be sent. The periodic TM(3,25) will report the current operating mode on the 'operating mode status' word.
TC(8, 4)	210	<p>"Go to Init"</p> <p>Same telemetries as TC(8,4) "Go to Boot" (replace 'boot' by 'init')</p>
TC(8, 4)	220	<p>"Go to Ready (health monitor)"</p> <p>Same telemetries as TC(8,4) "Go to Boot" (replace 'boot' by 'health monitor')</p>



TC(8, 4)	230	"Go to Ready (health check)" Same telemetries as TC(8,4) "Go to Boot" (replace 'boot' by 'health check')
TC(8, 4)	240	"Go to Ready (regeneration)" Same telemetries as TC(8,4) "Go to Boot" (replace 'boot' by 'regeneration')
TC(8, 4)	250	"Go to Run (startup)" Same telemetries as TC(8,4) "Go to Boot" (replace 'boot' by 'startup')
TC(8, 4)	260	"Go to Run (defrost)" Same telemetries as TC(8,4) "Go to Boot" (replace 'boot' by 'defrost')
TC(8, 4)	270	"Go to Run (normal)" Same telemetries as TC(8,4) "Go to Boot" (replace 'boot' by 'normal')
TC(8, 4) (scos 2000 critical)	280	"Go to Shutdown" Same telemetries as TC(8,4) "Go to Boot" (replace 'boot' by 'shutdown')
TC(8, 4)	301	"Set Initial Heatup Bed Position" <ol style="list-style-type: none"> 1. If this telecommand is not available in the current operating mode, a TM(1,2) with the failure code "illegal application data" will be sent. 2. If there was a problem during the process (from example bad position requested) a TM(1,2) with the failure code "illegal application data" will be sent. 3. For all other cases a TM(1,1) and / or TM(1,3) will be reported. The periodic TM(3,25) will report the current state of the beds (heatup, desorb etc...) on the 'Beds status MSB' and 'Beds status LSB' fields indicating that the telecommand was successfully executed.
TC(8, 4)	310	"Return to initial Beds states" <ol style="list-style-type: none"> 1. If this telecommand is not available in the current operating mode, a TM(1,2) with the failure code "illegal application data" will be sent. 2. For all other cases a TM(1,1) and / or TM(1,3) will be reported. The periodic TM(3,25) will report the current state of the beds (heatup, desorb etc...) on the 'Beds status MSB' and 'Beds status LSB' fields indicating that the telecommand was successfully executed.
TC(8, 4) (scos 2000 critical)	401	"Set Bed State" <ol style="list-style-type: none"> 1. If this telecommand is not available in the current operating mode, a TM(1,2) with the failure code "illegal application data" will be sent. 2. If there was a problem during the process (from example bad bed requested, bad state requested...) a TM(1,2) with the failure code "illegal application data" will be sent. 3. For all other cases a TM(1,1) and / or TM(1,3) will be reported. The periodic TM(3,25) will report the current state of the beds (heatup, desorb etc...) on the 'Beds status MSB' and 'Beds status LSB' fields indicating that the telecommand was successfully executed.
TC(8, 4) (scos 2000 critical)	501	"Set Device State" <ol style="list-style-type: none"> 1. If this telecommand is not available in the current operating mode, a TM(1,2) with the failure code "illegal application data" will be sent. 2. If there was a problem during the process (from example bad device requested...) a TM(1,2) with the failure code "illegal application data" will be sent. 3. For all other cases a TM(1,1) and / or TM(1,3) will be reported. The periodic TM(3,25) will report the current state of the devices on the 'Device status' field indicating that the telecommand was successfully executed.
TC(8, 4) (scos 2000 critical)	600	"Stop Process" TM(1,1) and / or TM(1,3) if telecommand was successfully proceeded else TM(1,2)
TC(9, 4)	none	TM(1,1) and / or TM(1,3) and / or TM(1,7) if telecommand was successfully proceeded else TM(1,2)
TC(9, 5)	none	TM(1,1) and / or TM(1,3) and / or TM(1,7) if telecommand was successfully proceeded else TM(1,2)
TC(9, 7)	none	If telecommand was successfully proceeded TM(1,1) and/or TM(1,3) followed by a



		TM(9,9) else TM(1,2)
TC(14, 1)	none	TM(1,1) and / or TM(1,3) and / or TM(1,7) if telecommand was successfully proceeded else TM(1,2)
TC(14, 2)	none	TM(1,1) and / or TM(1,3) and / or TM(1,7) if telecommand was successfully proceeded else TM(1,2)
TC(14, 3)	none	If telecommand was successfully proceeded TM(1,1) and / or TM(1,3) followed by a TM(14,4) else TM(1,2)
TC(17, 1)	none	If telecommand was successfully proceeded TM(1,1) and / or TM(1,3) followed by a TM(17,2) else TM(1,2)

Table 10-28. TC responses



10.5. TC conditions

The following table shows the conditions that enable a successful execution of all telecommands.

“C1” is taken from TM(3, 25): “Operating Mode Status” → “Current State”.

“C2” is taken from TM(3, 25): “Operating Mode Status” → “Current Process”

“C3” is taken from TM(3, 25): “Operating Mode Status” → “Applicative Software Transfer Status”

To be launched, “C1” AND “C2” AND “C3” shall be verified.

(*) : applies to boot mode only.

TC	Fct ID Act ID SID	Name	C1 (TC can be launched on the specified modes: 'X')										C2 Current Process = NONE	C3 ASW Transfer Status = 0 (*)
			Boot	Init	Health Monitor	Health Check	Regeneration	Startup	Defrost	Normal	Shutdown			
TC(6,2)	None	Memory Load	X	X	X	X	X	X	X	X	X	X	X	
TC(6,5)	None	Memory Dump	X	X	X	X	X	X	X	X	X	X	X	
TC(6,9)	None	Memory Check	X	X	X	X	X	X	X	X	X	X	X	
TC(8, 4)	000	Transfer ASW	X										X	
TC(8, 4)	100	Test PM RAM	X										X	
TC(8, 4)	110	Test DM RAM	X										X	
TC(8, 4)	120	Test PM PROM	X	X									X	
TC(8, 4)	130	Test DM EEPROM	X	X									X	
TC(8, 4)	200	Go to Boot	X	X										
TC(8, 4)	210	Go to Init	X	X	X	X	X							X
TC(8, 4)	220	Go to Health Monitor		X	X	X	X	X	X	X				
TC(8, 4)	230	Go to Health Check			X									
TC(8, 4)	240	Go to Regeneration			X									
TC(8, 4)	250	Go to Startup			X			X	X	X				
TC(8, 4)	260	Go to Defrost						X						
TC(8, 4)	270	Go to Normal						X						
TC(8, 4)	280	Go to Shutdown			X	X	X	X	X	X	X			
TC(8, 4)	301	Set Initial Heatup bed position		X	X	X	X					X		
TC(8, 4)	310	Return to Initial Beds States		X	X	X	X					X		
TC(8, 4)	401	Set Bed State		X	X	X	X	X	X	X	X			
TC(8, 4)	501	Set Device State		X	X	X	X	X	X	X	X			
TC(8, 4)	600	Stop Process	X	X	X	X	X	X	X	X	X			
TC(9, 4)	None	Enable Time Synchronization	X	X	X	X	X	X	X	X	X			
TC(9, 5)	None	Time Code	X	X	X	X	X	X	X	X	X			
TC(9, 7)	None	Enable Time Verification	X	X	X	X	X	X	X	X	X			
TC(14, 1)	None	Enable Generation of TM Packets	X	X	X	X	X	X	X	X	X			
TC(14, 2)	None	Disable Generation of TM Packets	X	X	X	X	X	X	X	X	X			
TC(14, 3)	None	Report Enabled TM Packets	X	X	X	X	X	X	X	X	X			
TC(17, 1)	None	Perform Connection Test	X	X	X	X	X	X	X	X	X			

Table 10-29. TC Conditions table



11. Planck Sorption Cooler System Budgets

11.1. Size and Mass Budget

The table below shows for each unit its size, nominal mass (i.e. current estimate, excluding margins) and the allocated mass.

Project Code	SCS Unit	# of	Dimensions (mm) L x W x D (3)	Current best estimate (kg)	Allocated mass (kg)
PSM1	SCCE (See note 4)	1	Located within PLFEU and HFI FPU	2.6	
PSM2	SCP	1 set	Diameter: 6.35	5.7	
PSM3	Sorption Cooler Compressor (SCC)	1	See ICD in annex 5	39.4	
PSM4	Sorption Cooler Electronics (SCE)	1	300x300x137	7.0	
PSM5A PSM5B	Harness SCE – SCC (See note 2)	1 set	L= from 2000 to 2588 OD=15 (5A) OD=40 (5B)	2.0	
PSM5C	Cryoharness 300K to 50K (and subplaform bracket)	1 set	Length = 1450 OD=5 mm (2 times)	1.0 (5)	
PSM5D	Harness SCE to subplaform bracket	1 set	Length = 1880 OD=5 mm (2 times)		
TOTAL	Mass Nominal	1		55.7	
PSR1	SCCE (See note 4)	1	Located within PLFEU and HFI FPU	2.6	
PSR2	SCP	1 set	Diameter: 6.35	5.7	
PSR3	Sorption Cooler Compressor (SCC)	1	See ICD in annex 5	39.4	
PSR4	Sorption Cooler Electronics (SCE)	1	300x300x137	7.0	
PSR5A PSR5B	Harness SCE – SCC (See note 2)	1 set	L= from 2000 to 2823 OD=15 (5A) OD=40 (5B)	2.0	
PSR5C	Cryoharness 300K to 50K (and subplaform bracket)	1 set	Length = 1450 OD=5 mm (2 times)	1.0 (5)	
PSR5D	Harness SCE to subplaform bracket	1 set	Length = 2400 OD=5 mm (2 times)		
TOTAL	Mass Redundant	1		55.7	
TOTAL	(Sum nominal plus Redundant SCS)	2		111.4	
	TOTAL ALLOCATION				132

Table 11-1

Notes:



- 1) Values are taken from IIDB SCS 3.1
- 2) The masses of the SCE to SCC, and SCE to SCCE, have not yet been estimated with respect to the real length given in this table
- 3) Size includes feet and connectors. Detailed dimensions are given in annex ICD.
- 4) Mass includes 1 kg for the TSA per TMU
- 5) JPL have to supply the mass of the cable and bracket that need to be added to the SCP PSM/R2 for their cable that goes along the pipe from the PSR5C to the PSM/R1(SCCE). This mass will be subtracted from the mass of PSM5C/PSM5D and PSR5C/PSR5D so that the current best estimate mass of the cabling running from the SCE to the PSM/R1(SCCE) remains unaltered.

11.2. Power Budget

The power load on the 28V main-bus for the Sorption Cooler Subsystem is as follows : separate power lines are required from the spacecraft power subsystem to the SCE for the power to the SCE itself, and the power supplied through the SCE to the SCC. Thus two LCL's are required for each SCE making a total of four in all.

Operating mode	1 st Line BOL (W)	2 nd Line BOL (W)	1 st Line EOL (W)	2 nd Line EOL (W)	Both lines Peak (W)
BOOT & INIT Modes	110	0	100	0	16
READY & RUN Modes	110	426	100	470	64

Table 11-2

Notes:

- 1) the total load on main bus for the nominal or redundant SCE shall be inferior to 570 W at a given operating point
- 2) The difference between the power consumption of the SCC BOL to EOL is due to the expected degradation in the beds of the SCC.
- 3) It is assumed that inside the PCDU each line contains ON/OFF switching and current limiters.



SCS Appendices



Appendix 1: SCS LookUp Table (LUT)

A1.1 LUT Description

Pos = position in EEPROM memory (32 bits). Each parameter size is 32 bits (nevertheless 16 bits is enough for most of them).

Range = range of values that accepts the software.

Transfer Function and steps:

- When transfer function is 1, 0.1, 0.01, $1\exp(-x)$: *precision = transfer function*
- When transfer function is a sensor : Tx, Px, TEx, lx : *precision = 1*
- When transfer function is N/A : *precision = 1* (There is no step for the SW_AUTO_FUNCTIONS parameter)

Signed / Unsigned parameters: all parameters must be sent as unsigned integer except for HW_CAL_T3_xx, HW_CAL_T4_xx, HW_CAL_T5_xx, HW_CAL_T6_xx that must be sent as signed integer. Signed integer is defined as follow: positive number → example 10 = 0xa. Negative number → example -10 = 0xFFFFF6.

Type: families of parameters.

- S Software: parameters that affects the on-board software.
- PT Sorption Cooler Powers and Times: parameters that affects heaters powers and times.
- HR Health Check and Regeneration Procedures: health check and regeneration parameters.
- R Run mode transitions: run mode transitions (startup to defrost etc...) parameters
- FC Fault Conditions and Bad Bed Detection: failure detection, FDIR parameters.
- PO PID and Open Loop Algorithms: open loop and pid regulators parameters.
- HR Heaters resistances: heaters resistances for power calculations.
- CA Calibrations: calibrations for conversion to physical values.



Planck LFI
Sorption Cooler System
User Manual

Document No.: PL-LFI-PST-MA-002
 Issue/Rev. No.: 3.0
 Date: 20 March 2009

Pos	Parameter Name	Short Description	Range	Transfer Function	Unit	Type
0x00	SW_AUTO_FUNCTIONS	Autonomous functions that can be enabled or disabled	(see Table A1- 2)	N.A	None	S
0x01	SW_ASW_ADR	Base address in EEPROM of the applicative software to use	0x80000000→0x8007ffff	N.A	None	S
0x02	SW_CHECKSUM_1_ADR	Base address in EEPROM of "checksums eeprom version 1"	0x80000000→0x8003ffff	N.A	None	S
0x03	SW_CHECKSUM_N_ADR	Base address in EEPROM of "checksums eeprom version n"	0x80040000→0x8007ffff	N.A	None	S
0x04	SW_TEST_EXT_TIMER_LENGTH	Duration set to external timers for auto tests in init mode	0→0x7ffffff	0.5	s	S
0x05	SW_TEST_FPGA_TIMER_LENGTH	Duration set to fpga timer for auto tests in init mode	0→0x7ffffff	0.5	ns	S
0x06	SENSORS_MEAN_T	Number of read to average sensor T1	0→0xffffffff	1	None	S
0x07	SENSORS_MEAN_T+1	Number of read to average sensor T2	0→0xffffffff	1	None	S
0x08	SENSORS_MEAN_T+2	Number of read to average sensor T3	0→0xffffffff	1	None	S
0x09	SENSORS_MEAN_T+3	Number of read to average sensor T4	0→0xffffffff	1	None	S
0x0A	SENSORS_MEAN_T+4	Number of read to average sensor T5	0→0xffffffff	1	None	S
0x0B	SENSORS_MEAN_T+5	Number of read to average sensor T6	0→0xffffffff	1	None	S
0x0C	SENSORS_MEAN_T+6	Number of read to average sensor T7	0→0xffffffff	1	None	S
0x0D	SENSORS_MEAN_T+7	Number of read to average sensor T8	0→0xffffffff	1	None	S
0x0E	SENSORS_MEAN_T+8	Number of read to average sensor T9	0→0xffffffff	1	None	S
0x0F	SENSORS_MEAN_T+9	Number of read to average sensor T10	0→0xffffffff	1	None	S
0x10	SENSORS_MEAN_T+10	Number of read to average sensor T11	0→0xffffffff	1	None	S
0x11	SENSORS_MEAN_T+11	Number of read to average sensor T12	0→0xffffffff	1	None	S
0x12	SENSORS_MEAN_T+12	Number of read to average sensor T13	0→0xffffffff	1	None	S
0x13	SENSORS_MEAN_T+13	Number of read to average sensor T14	0→0xffffffff	1	None	S
0x14	SENSORS_MEAN_T+14	Number of read to average sensor T15	0→0xffffffff	1	None	S
0x15	SENSORS_MEAN_T+15	Number of read to average sensor T16	0→0xffffffff	1	None	S
0x16	SENSORS_MEAN_T+16	Number of read to average sensor T17	0→0xffffffff	1	None	S
0x17	SENSORS_MEAN_T+17	Number of read to average sensor T18	0→0xffffffff	1	None	S
0x18	SENSORS_MEAN_T+18	Number of read to average sensor T20	0→0xffffffff	1	None	S
0x19	SENSORS_MEAN_T+19	Number of read to average sensor T21	0→0xffffffff	1	None	S
0x1A	SENSORS_MEAN_T+20	Number of read to average sensor T22	0→0xffffffff	1	None	S
0x1B	SENSORS_MEAN_T+21	Number of read to average sensor T23	0→0xffffffff	1	None	S
0x1C	SENSORS_MEAN_T+22	Number of read to average sensor T24	0→0xffffffff	1	None	S
0x1D	SENSORS_MEAN_T+23	Number of read to average sensor T25	0→0xffffffff	1	None	S



Planck LFI
Sorption Cooler System
User Manual

Document No.: PL-LFI-PST-MA-002
 Issue/Rev. No.: 3.0
 Date: 20 March 2009

0x1E	SENSORS_MEAN_T+24	Number of read to average sensor T26	0→0xffffffff	1	None	S
0x1F	SENSORS_MEAN_T+25	Number of read to average sensor T27	0→0xffffffff	1	None	S
0x20	SENSORS_MEAN_T+26	Number of read to average sensor T28	0→0xffffffff	1	None	S
0x21	SENSORS_MEAN_T+27	Number of read to average sensor T29	0→0xffffffff	1	None	S
0x22	SENSORS_MEAN_T+28	Number of read to average sensor T30	0→0xffffffff	1	None	S
0x23	SENSORS_MEAN_P	Number of read to average sensor P1	0→0xffffffff	1	None	S
0x24	SENSORS_MEAN_P+1	Number of read to average sensor P2	0→0xffffffff	1	None	S
0x25	SENSORS_MEAN_P+2	Number of read to average sensor P3	0→0xffffffff	1	None	S
0x26	SENSORS_MEAN_P+3	Number of read to average sensor P4	0→0xffffffff	1	None	S
0x27	SENSORS_MEAN_P+4	Number of read to average sensor P5	0→0xffffffff	1	None	S
0x28	SENSORS_MEAN_P+5	Number of read to average sensor P6	0→0xffffffff	1	None	S
0x29	SENSORS_MEAN_P+6	Number of read to average sensor P7	0→0xffffffff	1	None	S
0x2A	SENSORS_MEAN_P+7	Number of read to average sensor P8	0→0xffffffff	1	None	S
0x2B	SENSORS_MEAN_TEST	Number of read to average sensor VGAIN	0→0xffffffff	1	None	S
0x2C	SENSORS_MEAN_TEST+1	Number of read to average sensor VOFF	0→0xffffffff	1	None	S
0x2D	SENSORS_MEAN_TEST+2	Number of read to average sensor CAL1	0→0xffffffff	1	None	S
0x2E	SENSORS_MEAN_TEST+3	Number of read to average sensor CAL2	0→0xffffffff	1	None	S
0x2F	SENSORS_TRESEHOLD	The first 'threshold' values is not taken into account for the average calculation of sensors.	0→0xffffffff	1	None	S
0x30	POWER_HEATUP_BEDS	Bed 0 Heatup power for normal operation	0→429496729,5	0.1	W	PT
0x31	POWER_HEATUP_BEDS+1	Bed 1 Heatup power for normal operation	0→429496729,5	0.1	W	PT
0x32	POWER_HEATUP_BEDS+2	Bed 2 Heatup power for normal operation	0→429496729,5	0.1	W	PT
0x33	POWER_HEATUP_BEDS+3	Bed 3 Heatup power for normal operation	0→429496729,5	0.1	W	PT
0x34	POWER_HEATUP_BEDS+4	Bed 4 Heatup power for normal operation	0→429496729,5	0.1	W	PT
0x35	POWER_HEATUP_BEDS+5	Bed 5 Heatup power for normal operation	0→429496729,5	0.1	W	PT
0x36	POWER_DESORB_BED	Bed 0 Desorb power for normal operation	0→429496729,5	0.1	W	PT
0x37	POWER_DESORB_BED+1	Bed 1 Desorb power for normal operation	0→429496729,5	0.1	W	PT
0x38	POWER_DESORB_BED+2	Bed 2 Desorb power for normal operation	0→429496729,5	0.1	W	PT
0x39	POWER_DESORB_BED+3	Bed 3 Desorb power for normal operation	0→429496729,5	0.1	W	PT
0x3A	POWER_DESORB_BED+4	Bed 4 Desorb power for normal operation	0→429496729,5	0.1	W	PT
0x3B	POWER_DESORB_BED+5	Bed 5 Desorb power for normal operation	0→429496729,5	0.1	W	PT
0x3C	POWER_HEATUP_BEDS_STARTUP	Bed 0 Heatup power for startup operation	0→429496729,5	0.1	W	PT
0x3D	POWER_HEATUP_BEDS_STARTUP+1	Bed 1 Heatup power for startup operation	0→429496729,5	0.1	W	PT



Planck LFI
Sorption Cooler System
User Manual

Document No.: PL-LFI-PST-MA-002
 Issue/Rev. No.: 3.0
 Date: 20 March 2009

0x3E	POWER_HEATUP_BEDS_STARTUP+2	Bed 2 Heatup power for startup operation	0→429496729,5	0.1	W	PT
0x3F	POWER_HEATUP_BEDS_STARTUP+3	Bed 3 Heatup power for startup operation	0→429496729,5	0.1	W	PT
0x40	POWER_HEATUP_BEDS_STARTUP+4	Bed 4 Heatup power for startup operation	0→429496729,5	0.1	W	PT
0x41	POWER_HEATUP_BEDS_STARTUP+5	Bed 5 Heatup power for startup operation	0→429496729,5	0.1	W	PT
0x42	POWER_DESORB_BEDS_STARTUP	Bed 0 Desorb power for startup operation	0→429496729,5	0.1	W	PT
0x43	POWER_DESORB_BEDS_STARTUP+1	Bed 1 Desorb power for startup operation	0→429496729,5	0.1	W	PT
0x44	POWER_DESORB_BEDS_STARTUP+2	Bed 2 Desorb power for startup operation	0→429496729,5	0.1	W	PT
0x45	POWER_DESORB_BEDS_STARTUP+3	Bed 3 Desorb power for startup operation	0→429496729,5	0.1	W	PT
0x46	POWER_DESORB_BEDS_STARTUP+4	Bed 4 Desorb power for startup operation	0→429496729,5	0.1	W	PT
0x47	POWER_DESORB_BEDS_STARTUP+5	Bed 5 Desorb power for startup operation	0→429496729,5	0.1	W	PT
0x48	POWER_LPSB	Low Pressure Stabilization Bed Power	0→42949672,95	0.01	W	PT
0x49	TIME_CYCLE_NORMAL	Cycle Time in Normal Mode	0→0x7FFFFFFF	0.5	S	PT
0x4A	TIME_GASGAP_ON_BEDS	Time to wait after entering bed cooldown phase before activating GGA	0→0x7FFFFFFF	0.5	S	PT
0x4B	TIME_GASGAP_ON_BEDS+1	Time to wait after entering bed cooldown phase before activating GGA	0→0x7FFFFFFF	0.5	S	PT
0x4C	TIME_GASGAP_ON_BEDS+2	Time to wait after entering bed cooldown phase before activating GGA	0→0x7FFFFFFF	0.5	S	PT
0x4D	TIME_GASGAP_ON_BEDS+3	Time to wait after entering bed cooldown phase before activating GGA	0→0x7FFFFFFF	0.5	S	PT
0x4E	TIME_GASGAP_ON_BEDS+4	Time to wait after entering bed cooldown phase before activating GGA	0→0x7FFFFFFF	0.5	S	PT
0x4F	TIME_GASGAP_ON_BEDS+5	Time to wait after entering bed cooldown phase before activating GGA	0→0x7FFFFFFF	0.5	S	PT
0x50	TIME_GASGAP_OFF_BEDS	Time to de-activate GGA before bed entering Heatup phase	0→0x7FFFFFFF	0.5	S	PT
0x51	TIME_GASGAP_OFF_BEDS+1	Time to de-activate GGA before bed entering Heatup phase	0→0x7FFFFFFF	0.5	S	PT
0x52	TIME_GASGAP_OFF_BEDS+2	Time to de-activate GGA before bed entering Heatup phase	0→0x7FFFFFFF	0.5	S	PT
0x53	TIME_GASGAP_OFF_BEDS+3	Time to de-activate GGA before bed entering Heatup phase	0→0x7FFFFFFF	0.5	S	PT
0x54	TIME_GASGAP_OFF_BEDS+4	Time to de-activate GGA before bed entering Heatup phase	0→0x7FFFFFFF	0.5	S	PT
0x55	TIME_GASGAP_OFF_BEDS+5	Time to de-activate GGA before bed entering Heatup phase	0→0x7FFFFFFF	0.5	S	PT
0x56	HEALTHCHECK_DELTA_P_LP	Delta pressure low pressure	0→0xFFFFFFFF	P8	Psia	HR
0x57	HEALTHCHECK_TIME_LIMIT	Health check time out	0→0x7FFFFFFF	0.5	S	HR
0x58	HEALTHCHECK_TLPSB	LPSB temperature limit	0→0xFFFFFFFF	T17	K	HR
0x59	HEALTHCHECK_MAX_POWER	Maximum Power	0→429496729,5	0.1	W	HR
0x5A	HEALTHCHECK_MIN_POWER	Minimum Power	0→429496729,5	0.1	W	HR
0x5B	HEALTHCHECK_TBED_LIMIT	Bed temperature limit	0→0xFFFFFFFF	1	K	HR
0x5C	HEALTHCHECK_PBED_LIMIT	Bed pressure limit	0→0xFFFFFFFF	P1	Psia	HR
0x5D	HEALTHCHECK_DELTAT_COLD	Delta temperature cold	0→429496729,5	0.1	K	HR



Planck LFI
Sorption Cooler System
User Manual

Document No.: PL-LFI-PST-MA-002
 Issue/Rev. No.: 3.0
 Date: 20 March 2009

0x5E	HEALTHCHECK_TIME_LIMIT_COLD	Time for Cold End heaters activation	0→0x7FFFFFFF	0.5	S	HR
0x5F	REGENERATION_POWER	CE heater power to run the regeneration procedure	0→429496729,5	0.1	W	HR
0x60	REGENERATION_TEMPERATURE	Temperature to be maintained for the regeneration process	0→0xFFFFFFFF	1	K	HR
0x61	REGENERATION_MAX_PRESSURE	Maximum pressure in the HPST not to be exceeded	0→0xFFFFFFFF	P7	Psia	HR
0x62	REGENERATION_TIME	Time needed to maintain the CE at REGEN_TEMP to complete the regeneration process	0→0x7FFFFFFF	0.5	S	HR
0x63	REGENERATION_MAX_TIME	Maximum time allowed during a regeneration process	0→0x7FFFFFFF	0.5	S	HR
0x64	REGENERATION_GGON_TEMPERATURE	maximum CE temperature that allows the GGA to be turned ON	0→0xFFFFFFFF	1	K	HR
0x65	REGENERATION_DELTAT	Delta Temperature used for bang bang procedure	0→0xFFFFFFFF	1	K	HR
0x66	STARTUP_TIME_ADJUST_MDP	Conditioning Maximum Desorption Pressure	0→0xFFFFFFFF	P1→P6	Psia	R
0x67	STARTUP_TIME_ADJUST_MDT	Maximum Desorbing temperature	0→0xFFFFFFFF	1	K	R
0x68	STARTUP_TIME_ADJUST_MHT	Maximum Heatup Temperature	0→0xFFFFFFFF	1	K	R
0x69	STARTUP_TIME_ADJUST_MCTFIRST	Maximum cycle time (first cycle)	0→0x7FFFFFFF	0.5	S	R
0x6A	STARTUP_TIME_ADJUST_MCTNEXT	Maximum cycle time (next cycles)	0→0x7FFFFFFF	0.5	S	R
0x6B	STARTUP_ENTER_DEFROST_MTP	Maximum Tank Pressure	0→0xFFFFFFFF	P7	Psia	R
0x6C	STARTUP_ENTER_DEFROST_MJT_T7	Maximum JT Temperature (using T7)	0→0xFFFFFFFF	T7	K	R
0x6D	STARTUP_ENTER_DEFROST_MJT_T30	Maximum JT Temperature (using T30)	0→0xFFFFFFFF	T30	K	R
0x6E	STARTUP_ENTER_DEFROST_FLOW	Condition to enter in defrost : Flow Expected	0→0xFFFFFFFF	1		R
0x6F	STARTUP_EXIT_DEFROST_TIME	Defrost Time out (maximum defrost duration)	0→0x7FFFFFFF	0.5	S	R
0x70	STARTUP_EXIT_DEFROST_MJT_T7	Exit Defrost Condition (using T7)	0→0xFFFFFFFF	T7	K	R
0x71	STARTUP_EXIT_DEFROST_MJT_T30	Exit Defrost Condition (using T30)	0→0xFFFFFFFF	T30	K	R
0x72	STARTUP_ENTER_NORMAL_MCONJT_T7	Maximum startup JT Temperature (using T7)	0→0xFFFFFFFF	T7	K	R
0x73	STARTUP_ENTER_NORMAL_MCONJT_T30	Maximum startup JT Temperature (using T30)	0→0xFFFFFFFF	T30	K	R
0x74	STARTUP_ENTER_NORMAL_MINCONJT	Minimum Tank Pressure In Startup operation	0→0xFFFFFFFF	P7	Psia	R
0x75	STARTUP_ENTER_NORMAL_MAXCONJT	Maximum Tank Pressure In Startup operation	0→0xFFFFFFFF	P7	Psia	R
0x76	NORMAL_ENTER_STARTUP_MINNTP	Minimum Tank Pressure in Normal operation	0→0xFFFFFFFF	P7	Psia	R
0x77	NORMAL_ENTER_STARTUP_MAXNTP	Maximum Tank Pressure in Normal operation	0→0xFFFFFFFF	P7	Psia	R
0x78	NORMAL_ENTER_STARTUP_MNCET	Maximum Normal compressor element temperature	0→0xFFFFFFFF	1	K	R
0x79	NORMAL_ENTER_STARTUP_MNJT_T7	Maximum normal JT Temperature (using T7)	0→0xFFFFFFFF	T7	K	R
0x7A	NORMAL_ENTER_STARTUP_MNJT_T30	Maximum normal JT Temperature (using T30)	0→0xFFFFFFFF	T30	K	R
0x7B	STARTUP_LPSB_HIGH_TEMPERATURE_LIMIT	LPSB 'bang bang' procedure higher limit	0→0xFFFFFFFF	T18	K	R
0x7C	STARTUP_LPSB_LOW_TEMPERATURE_LIMIT	LPSB 'bang bang' procedure lower limit	0→0xFFFFFFFF	T18	K	R
0x7D	STARTUP_HPST_PRESSURE_LIMIT	Startup HPST Pressure Limit	0→0xFFFFFFFF	P7	Psia	R



Planck LFI
Sorption Cooler System
User Manual

Document No.: PL-LFI-PST-MA-002
 Issue/Rev. No.: 3.0
 Date: 20 March 2009

0x7E	NORMAL_H8_RATE_IF_H7_BAD	H8 on % when H7 is bad (see 7.3.1.1.7 Heaters Failure)	0→0xFFFFFFFF	1	None	R
0x7F	FAULT_COND_BED_TEMPERATURE_LIMIT	Failure if bed temperature greater than this limit	0→0xFFFFFFFF	1	K	FC
0x80	FAULT_COND_BED_PRESSURE_LIMIT	Failure if bed pressure greater than this limit	0→0xFFFFFFFF	P1	Psia	FC
0x81	FAULT_COND_LPSB_TEMPERATURE_LIMIT	Failure if LPSB temperature greater than this limit	0→0xFFFFFFFF	T17	K	FC
0x82	FAULT_COND_PRT_TEMPERATURE_DEFAULT	Default temp. for all PRTs sensors in case of failure	0→0xFFFFFFFF	T15	K	FC
0x83	FAULT_COND_JT_TEMPERATURE_DEFAULT	Default temp. for JT sensors in case of failure	0→0xFFFFFFFF	T30	K	FC
0x84	BAD_BED_DETECT_COOL_TEMP_LIMIT	Bad Bed Detection: cooldown bed must be removed if its T is higher than this limit	0→0xFFFFFFFF	1	K	FC
0x85	BAD_BED_DETECT_COOL_PRESSURE_LIMIT	Bad Bed Detection: cooldown bed must be removed if its pressure is higher than this limit	0→0xFFFFFFFF	P1	Psia	FC
0x86	BAD_BED_DETECT_HEATUP_TEMP_LIMIT	Bad Bed Detection: heatup bed must be removed if its temperature is higher than this limit	0→0xFFFFFFFF	1	K	FC
0x87	BAD_BED_DETECT_HEATUP_PRESSURE_LIMIT	Bad Bed Detection: heatup bed must be removed if its pressure is higher than this limit	0→0xFFFFFFFF	P1	Psia	FC
0x88	BAD_BED_DETECT_CYCLE_PERIOD	Bad Bed Detection: Bad Bed Detection is enabled if cycle time is higher than this limit	0→0x7FFFFFFF	0.5	S	FC
0x89	FAULT_ELECTRONIC_28V_DEFAULT	If 28 volts is wrong use this value to calculate the power	0→429496729,5	0.1	V	FC
0x8a	FAULT_ELECTRONIC_28V_UP_LIMIT	If 28 volts is greater than this value, 28 volts is wrong	0→429496729,5	0.1	V	FC
0x8b	FAULT_ELECTRONIC_28V_LOW_LIMIT	If 28 volts is lower than this value, 28 volts is wrong	0→429496729,5	0.1	V	FC
0x8c	FAULT_ELECTRONIC_12V_UP_LIMIT	If 12 volts is greater than this value, 12 volts is wrong	0→429496729,5	0.1	V	FC
0x8d	FAULT_ELECTRONIC_12V_LOW_LIMIT	If 12 volts is lower than this value, 12 volts is wrong	0→429496729,5	0.1	V	FC
0x8e	FAULT_ELECTRONIC_12V_TIME	See FMECA Chapter 7	0→0x7FFFFFFF	0.5	S	FC
0x8f	FAULT_ELECTRONIC_TEMP_FIRST	See FMECA Chapter 7	0→0xFFFFFFFF	TE1-2-3	K	FC
0x90	FAULT_ELECTRONIC_TEMP_SECOND	See FMECA Chapter 7	0→0xFFFFFFFF	TE1-2-3	K	FC
0x91	FAULT_ELECTRONIC_ADC_REF	Digital output from reference sensor shall be compared to this value +- delta	0→0xFFFFFFFF	1	None	FC
0x92	FAULT_ELECTRONIC_ADC_DELTA	Digital output from reference sensor shall be compared to reference value +- this parameter	0→0xFFFFFFFF	1	None	FC
0x93	FAULT_HEATERS_H2I_ON	Gas Gaps current higher than this limit when active	0→0xFFFFFFFF	Ih21	A	FC
0x94	FAULT_HEATERS_H2I_OFF	Gas Gap current must be lower than this limit when inactive	0→0xFFFFFFFF	Ih21	A	FC
0x95	FAULT_HEATERS_H7	I measured on H7 must be equal to I applied (from DAC value) ± this parameter	0→4294967,295	0.001	A	FC
0x96	FAULT_HEATERS_H31	I measured on H31/H32 must be equal to I applied (from DAC value) ± this parameter	0→4294967,295	0.001	A	FC
0x97	FAULT_HEATERS_H8	If T17 and T18 temperature are above this limit, H8 is always on (Failure from FDIR)	0→0xFFFFFFFF	T17	K	FC
0x98	FAULT_HEATERS_H34_H35_T_UP_T7	H34/H35 bad if JT temperature up this limit (using T7)	0→0xFFFFFFFF	T7	K	FC
0x99	FAULT_HEATERS_H34_H35_T_UP_T30	H34/H35 bad if JT temperature up this limit (using T30)	0→0xFFFFFFFF	T30	K	FC
0x9a	FAULT_HEATERS_H34_H35_DELTA_T	H34/H35 bad if this value is not reached within 'rise time'	0→0xFFFFFFFF	1	K	FC
0x9b	FAULT_HEATERS_H34_H35_RISE_TIME	H34/H35 bad if 'delta T' is not reached within this time value	0→0x7FFFFFFF	0.5	s	FC
0x9c	PID_SETPOINT_T5	Set Point of the L3 PID regulator (using T5)	0→0xFFFFFFFF	T5	K	PO
0x9d	PID_SETPOINT_T6	Set Point of the L3 PID regulator (using T6)	0→0xFFFFFFFF	T6	K	PO



Planck LFI
Sorption Cooler System
User Manual

Document No.: PL-LFI-PST-MA-002
 Issue/Rev. No.: 3.0
 Date: 20 March 2009

0x9e	PID_P	P parameter of the L3 PID regulator	0→429496729,5	0.1	None	PO
0x9f	PID_I	I parameter of the L3 PID regulator	0→42949672,95	0.01	None	PO
0xa0	PID_D	D parameter of the L3 PID regulator	0→429496729,5	0.1	None	PO
0xa1	PID_RATE	Sampling rate of the L3 PID regulator	0→0x7FFFFFFF	0.5	S	PO
0xa2	PID_UPPER_LIMIT	Upper Limit of the L3 PID regulator	0→0xFFFFFFFF	1	V	PO
0xa3	PID_LOWER_LIMIT	Lower Limit of the L3 PID regulator	0→0xFFFFFFFF	1	V	PO
0xa4	PID_TEMPERATURE_LIMIT_T5	Temperature Limit of the L3 PID regulator (using T5)	0→0xFFFFFFFF	T5	K	PO
0xa5	PID_TEMPERATURE_LIMIT_T6	Temperature Limit of the L3 PID regulator (using T6)	0→0xFFFFFFFF	T6	K	PO
0xa6	OPEN_LOOP_R1	R1 value from the open loop algorithm	0→42949672,95	0.01	Ohm	PO
0xa7	OPEN_LOOP_N	Number of previous Q_LFI value to average from open loop	0→0xFFFFFFFF	1	1	PO
0xa8	HW_HEATERS_RB	Loss resistor 'rb' for bed 0 power calculation	0→42949672,95	0.01	Ohm	HR
0xa9	HW_HEATERS_RB+1	Loss resistor 'rb' for bed 1 power calculation	0→42949672,95	0.01	Ohm	HR
0xaa	HW_HEATERS_RB+2	Loss resistor 'rb' for bed 2 power calculation	0→42949672,95	0.01	Ohm	HR
0xab	HW_HEATERS_RB+3	Loss resistor 'rb' for bed 3 power calculation	0→42949672,95	0.01	Ohm	HR
0xac	HW_HEATERS_RB+4	Loss resistor 'rb' for bed 4 power calculation	0→42949672,95	0.01	Ohm	HR
0xad	HW_HEATERS_RB+5	Loss resistor 'rb' for bed 5 power calculation	0→42949672,95	0.01	Ohm	HR
0xae	HW_HEATERS_RBL	Loss resistor 'rbl' for bed 0 power calculation	0→42949672,95	0.01	Ohm	HR
0xaf	HW_HEATERS_RBL+1	Loss resistor 'rbl' for bed 1 power calculation	0→42949672,95	0.01	Ohm	HR
0xb0	HW_HEATERS_RBL+2	Loss resistor 'rbl' for bed 2 power calculation	0→42949672,95	0.01	Ohm	HR
0xb1	HW_HEATERS_RBL+3	Loss resistor 'rbl' for bed 3 power calculation	0→42949672,95	0.01	Ohm	HR
0xb2	HW_HEATERS_RBL+4	Loss resistor 'rbl' for bed 4 power calculation	0→42949672,95	0.01	Ohm	HR
0xb3	HW_HEATERS_RBL+5	Loss resistor 'rbl' for bed 5 power calculation	0→42949672,95	0.01	Ohm	HR
0xb4	HW_HEATERS_RV	Loss resistor 'rv' for bed 0 power calculation	0→42949672,95	0.01	Ohm	HR
0xb5	HW_HEATERS_RV+1	Loss resistor 'rv' for bed 1 power calculation	0→42949672,95	0.01	Ohm	HR
0xb6	HW_HEATERS_RV+2	Loss resistor 'rv' for bed 2 power calculation	0→42949672,95	0.01	Ohm	HR
0xb7	HW_HEATERS_RV+3	Loss resistor 'rv' for bed 3 power calculation	0→42949672,95	0.01	Ohm	HR
0xb8	HW_HEATERS_RV+4	Loss resistor 'rv' for bed 4 power calculation	0→42949672,95	0.01	Ohm	HR
0xb9	HW_HEATERS_RV+5	Loss resistor 'rv' for bed 5 power calculation	0→42949672,95	0.01	Ohm	HR
0xba	HW_HEATERS_RVL	Loss resistor 'rvl' for bed 0 power calculation	0→42949672,95	0.01	Ohm	HR
0xbb	HW_HEATERS_RVL+1	Loss resistor 'rvl' for bed 1 power calculation	0→42949672,95	0.01	Ohm	HR
0xbc	HW_HEATERS_RVL+2	Loss resistor 'rvl' for bed 2 power calculation	0→42949672,95	0.01	Ohm	HR
0xbd	HW_HEATERS_RVL+3	Loss resistor 'rvl' for bed 3 power calculation	0→42949672,95	0.01	Ohm	HR



Planck LFI
Sorption Cooler System
User Manual

Document No.: PL-LFI-PST-MA-002
 Issue/Rev. No.: 3.0
 Date: 20 March 2009

0xbe	HW_HEATERS_RVL+4	Loss resistor 'rvl' for bed 4 power calculation	0→42949672,95	0.01	Ohm	HR
0xbf	HW_HEATERS_RVL+5	Loss resistor 'rvl' for bed 5 power calculation	0→42949672,95	0.01	Ohm	HR
0xc0	HW_HEATERS_RH7	H7 resistor for LPSB power H7 calculation	0→42949672,95	0.01	Ohm	HR
0xc1	HW_HEATERS_RH31	H31 resistor for LR3 (nominal) power calculation	0→42949672,95	0.01	Ohm	HR
0xc2	HW_HEATERS_RH32	H32 resistor for LR3 (redundant) power calculation	0→42949672,95	0.01	Ohm	HR
0xc3	HW_CAL_ADC_V31	Calibration ADC to volts for 31 volts	0→42949672,95	0.01	None	CA
0xc4	HW_CAL_ADC_V28	Calibration ADC to volts for 28 volts	0→42949672,95	0.01	None	CA
0xc5	HW_CAL_ADC_V12	Calibration ADC to volts for 12 volts	0→42949672,95	0.01	None	CA
0xc6	HW_CAL_GAIN_H7	GAINh7 part of lh7 = GAINh7 + OFFSETh7	0→429496,7295	0.0001	A	CA
0xc7	HW_CAL_OFFSET_H7	OFFSETh7 part of lh7 = GAINh7 + OFFSETh7	0→429496,7295	0.0001	A	CA
0xc8	HW_CAL_GAIN_H31	GAINh31 part of lh31 = GAINh31 + OFFSETh31	0→429496,7295	0.0001	A	CA
0xc9	HW_CAL_OFFSET_H31	OFFSETh31 part of lh31 = GAINh31 + OFFSETh31	0→429496,7295	0.0001	A	CA
0xca	HW_CAL_GAIN_H32	GAINh32 part of lh32 = GAINh32 + OFFSETh32	0→429496,7295	0.0001	A	CA
0xcb	HW_CAL_OFFSET_H32	OFFSETh32 part of lh32 = GAINh32 + OFFSETh32	0→429496,7295	0.0001	A	CA
0xcc	HW_CAL_T3_R0	T3(ADC) → T3(K). Resistance = T3(ADC) * R0 / 65535 + R1	0→4294967,295	0.001	None	CA
0xcd	HW_CAL_T3_R1	T3(ADC) → T3(K). Resistance = T3(ADC) * R0 / 65535 + R1	0→4294967,295	0.001	None	CA
0xce	HW_CAL_T3_ZL	T3(ADC) → T3(K). Chebychev ZL coefficient	0→42,94967295	1.EXP-8	None	CA
0xcf	HW_CAL_T3_ZU	T3(ADC) → T3(K). Chebychev ZU coefficient	0→42,94967295	1.EXP-8	None	CA
0xd0	HW_CAL_T3_A0	T3(ADC) → T3(K). Chebychev A0 coefficient	0→4294,967295	1.EXP-6	None	CA
0xd1	HW_CAL_T3_A1	T3(ADC) → T3(K). Chebychev A1 coefficient	0→4294,967295	1.EXP-6	None	CA
0xd2	HW_CAL_T3_A2	T3(ADC) → T3(K). Chebychev A2 coefficient	0→4294,967295	1.EXP-6	None	CA
0xd3	HW_CAL_T3_A3	T3(ADC) → T3(K). Chebychev A3 coefficient	0→4294,967295	1.EXP-6	None	CA
0xd4	HW_CAL_T3_A4	T3(ADC) → T3(K). Chebychev A4 coefficient	0→4294,967295	1.EXP-6	None	CA
0xd5	HW_CAL_T3_A5	T3(ADC) → T3(K). Chebychev A5 coefficient	0→4294,967295	1.EXP-6	None	CA
0xd6	HW_CAL_T4_R0	T4(ADC) → T4(K). Resistance = T4(ADC) * R0 / 65535 + R1	0→4294967,295	0.001	None	CA
0xd7	HW_CAL_T4_R1	T4(ADC) → T4(K). Resistance = T4(ADC) * R0 / 65535 + R1	0→4294967,295	0.001	None	CA
0xd8	HW_CAL_T4_ZL	T4(ADC) → T4(K). Chebychev ZL coefficient	0→42,94967295	1.EXP-8	None	CA
0xd9	HW_CAL_T4_ZU	T4(ADC) → T4(K). Chebychev ZU coefficient	0→42,94967295	1.EXP-8	None	CA
0xda	HW_CAL_T4_A0	T4(ADC) → T4(K). Chebychev A0 coefficient	0→4294,967295	1.EXP-6	None	CA
0xdb	HW_CAL_T4_A1	T4(ADC) → T4(K). Chebychev A1 coefficient	0→4294,967295	1.EXP-6	None	CA
0xdc	HW_CAL_T4_A2	T4(ADC) → T4(K). Chebychev A2 coefficient	0→4294,967295	1.EXP-6	None	CA
0xdd	HW_CAL_T4_A3	T4(ADC) → T4(K). Chebychev A3 coefficient	0→4294,967295	1.EXP-6	None	CA



0xde	HW_CAL_T4_A4	T4(ADC) → T4(K). Chebychev A4 coefficient	0→4294,967295	1.EXP-6	None	CA
0xdf	HW_CAL_T4_A5	T4(ADC) → T4(K). Chebychev A5 coefficient	0→4294,967295	1.EXP-6	None	CA
0xe0	HW_CAL_T4_A6	T4(ADC) → T4(K). Chebychev A6 coefficient	0→4294,967295	1.EXP-6	None	CA
0xe1	HW_CAL_T5_R0	T5(ADC) → T5(K). Resistance = T5(ADC) * R0 / 65535 + R1	0→4294967,295	0.001	None	CA
0xe2	HW_CAL_T5_R1	T5(ADC) → T5(K). Resistance = T5(ADC) * R0 / 65535 + R1	0→4294967,295	0.001	None	CA
0xe3	HW_CAL_T5_ZL	T5(ADC) → T5(K). Chebychev ZL coefficient	0→42,94967295	1.EXP-8	None	CA
0xe4	HW_CAL_T5_ZU	T5(ADC) → T5(K). Chebychev ZU coefficient	0→42,94967295	1.EXP-8	None	CA
0xe5	HW_CAL_T5_A0	T5(ADC) → T5(K). Chebychev A0 coefficient	0→4294,967295	1.EXP-6	None	CA
0xe6	HW_CAL_T5_A1	T5(ADC) → T5(K). Chebychev A1 coefficient	0→4294,967295	1.EXP-6	None	CA
0xe7	HW_CAL_T5_A2	T5(ADC) → T5(K). Chebychev A2 coefficient	0→4294,967295	1.EXP-6	None	CA
0xe8	HW_CAL_T5_A3	T5(ADC) → T5(K). Chebychev A3 coefficient	0→4294,967295	1.EXP-6	None	CA
0xe9	HW_CAL_T5_A4	T5(ADC) → T5(K). Chebychev A4 coefficient	0→4294,967295	1.EXP-6	None	CA
0xea	HW_CAL_T5_A5	T5(ADC) → T5(K). Chebychev A5 coefficient	0→4294,967295	1.EXP-6	None	CA
0xeb	HW_CAL_T5_A6	T5(ADC) → T5(K). Chebychev A6 coefficient	0→4294,967295	1.EXP-6	None	CA
0xec	HW_CAL_T5_A7	T5(ADC) → T5(K). Chebychev A7 coefficient	0→4294,967295	1.EXP-6	None	CA
0xed	HW_CAL_T6_R0	T6(ADC) → T6(K). Resistance = T6(ADC) * R0 / 65535 + R1	0→4294967,295	0.001	None	CA
0xee	HW_CAL_T6_R1	T6(ADC) → T6(K). Resistance = T6(ADC) * R0 / 65535 + R1	0→4294967,295	0.001	None	CA
0xef	HW_CAL_T6_ZL	T6(ADC) → T6(K). Chebychev ZL coefficient	0→42,94967295	1.EXP-8	None	CA
0xf0	HW_CAL_T6_ZU	T6(ADC) → T6(K). Chebychev ZU coefficient	0→42,94967295	1.EXP-8	None	CA
0xf1	HW_CAL_T6_A0	T6(ADC) → T6(K). Chebychev A0 coefficient	0→4294,967295	1.EXP-6	None	CA
0xf2	HW_CAL_T6_A1	T6(ADC) → T6(K). Chebychev A1 coefficient	0→4294,967295	1.EXP-6	None	CA
0xf3	HW_CAL_T6_A2	T6(ADC) → T6(K). Chebychev A2 coefficient	0→4294,967295	1.EXP-6	None	CA
0xf4	HW_CAL_T6_A3	T6(ADC) → T6(K). Chebychev A3 coefficient	0→4294,967295	1.EXP-6	None	CA
0xf5	HW_CAL_T6_A4	T6(ADC) → T6(K). Chebychev A4 coefficient	0→4294,967295	1.EXP-6	None	CA
0xf6	HW_CAL_T6_A5	T6(ADC) → T6(K). Chebychev A5 coefficient	0→4294,967295	1.EXP-6	None	CA
0xf7	HW_CAL_T6_A6	T6(ADC) → T6(K). Chebychev A6 coefficient	0→4294,967295	1.EXP-6	None	CA
0xf8	HW_CAL_T7_R0	T7(ADC) → T7(K). Resistance = T7(ADC) * R0 / 65535 + R1	0→4294967,295	0.001	None	CA
0xf9	HW_CAL_T7_R1	T7(ADC) → T7(K). Resistance = T7(ADC) * R0 / 65535 + R1	0→4294967,295	0.001	None	CA
0xfa	HW_CAL_T7_A	T7(K) from T7(ADC). R=ADC * R0 / 65535 + R1. X = ln R. T (Kelvin) = exp(A - B . x)	0→429496,7295	0.0001	None	CA
0xfb	HW_CAL_T7_B	T7(K) from T7(ADC). R=ADC * R0 / 65535 + BR1 X = ln R. T (Kelvin) = exp(A - B . x)	0→429496,7295	0.0001	None	CA
0xfc	HW_CAL_T30_R0	T30(ADC) → T30(K). Resistance = T30(ADC) * R0 / 65535 + R1	0→4294967,295	0.001	None	CA
0xfd	HW_CAL_T30_R1	T30(ADC) → T30(K). Resistance = T30(ADC) * R0 / 65535 + R1	0→4294967,295	0.001	None	CA



0xfe	HW_CAL_T30_A	T30(K) from T3(ADC). $R=ADC * R0 / 65535 + R1$. $X = \ln R$. $T (Kelvin) = \exp(A - B . x)$	0→429496,7295	0.0001	None	CA
0xff	HW_CAL_T30_B	T30(K) from T3(ADC). $R=ADC * R0 / 65535 + R1$. $X = \ln R$. $T (Kelvin) = \exp(A - B . x)$	0→429496,7295	0.0001	None	CA
0x100	HW_CAL_TBED_UVA	UVA term for bed temperature calculation : $uV = tThermocouple * UVA / 65535 - UVB$	0→0xFFFFFFFF	1	None	CA
0x101	HW_CAL_TBED_UVB	UVB term for bed temperature calculation : $uV = tThermocouple * UVA / 65535 - UVB$	0→429496,7295	0.0001	None	CA
0x102	HW_CAL_TBED_TRA	TRA term for bed T calc. $r = tReferenceK * TRA / 65535 - (tReferenceK - 65535) * TRB / 65535$	0→0xFFFFFFFF	1	None	CA
0x103	HW_CAL_TBED_TRB	TRB term for bed temp. calc. $r = tReferenceK * TRA / 65535 - (tReferenceK - 65535) * TRB / 65535$	0→429496729,5	0.1	None	CA
0x104	RATE_BED_POWER_ADJUST	Bed heaters power readjustment frequency (number of sensors set between two power adjustment)	0→0xFFFFFFFF	1	None	PT

Table A1- 1

Bit	Function	Definition	Default
0	Boot mode applicative software transfer EEPROM→RAM	Transfer applicative software from eeprom to Ram enable/disable	FALSE
1	Boot autonomous hardware tests	Hardware tests at beginning of boot mode enable/disable. Performed tests are: PM PROM – PM RAM – DM RAM – DM EEPROM – 1553 – FPGA.	FALSE
2	Applicative autonomous hardware tests	Hardware tests at beginning of init mode enable/disable. Performed tests are: PM PROM – DM EEPROM – EXTERNAL TIMERS – ADC	FALSE
3	Run diagnostic Sorption Cooler	Run Sorption Cooler diagnostics enable/disable	TRUE
4	Run diagnostic Electronics	Run Electronics diagnostics enable / disable	TRUE
5	Run diagnostic bad heaters	Bad Heaters detection enable/disable	TRUE
6	Run diagnostic bad ADC	Bad ADC detection enable/disable	TRUE
7	Run diagnostic bad sensors	Action following bad sensor enable / disable	TRUE
8	Autonomous go to startup	Autonomous go to startup from normal mode (triggered by conditions) enable / disable	TRUE
9	Autonomous go to defrost	Autonomously go to defrost from startup (triggered by conditions) enable/disable (if disabled, enter in defrost only by command)	TRUE
10	Autonomous go to off-normal (autonomous bed removal / insertion)	Autonomously add/remove a bed enable/disable	TRUE
11	LR3 PID regulation enable	LR3 PID regulation enable/disable	TRUE
12	OPEN LOOP enable	Open loop procedure enable/disable	TRUE

Table A1- 2: autonomous functions FALSE = autonomy disabled. TRUE = autonomy enabled



A1.2 SCS Nom and Red LUT for Flight

In the following pages are reported the LUT values uploaded in SCS-N and R before launch. Most of Look Up Table (LUT) parameters must be set in accordance to SCS thermal boundary conditions. Main operational parameters can (and will) be adjusted only once actual values of the boundary interfaces will be known. For this reason, the following tables have been built on the basis of cryo test results and present predictions of flight conditions. They should be considered only as a basic starting set of values that have to be confirmed during flight operations.

The LookUp Table parameter values are defined depending on the following issues :

Thermal boundary conditions at interfaces

If the environment changes the SCS has to be "retuned" to insure same (or better) performance

TMU unit

LUT values depend on the physical components (and their performance) of each TMU like heaters, sensors, harness etc.

SCE unit

LUT electronic values depend on the specific components of the TMU like heaters, sensors calibration, harness etc.

All LUT parameters are subject to change in accordance with thermal environmental conditions found in flight

IMPORTANT

For SCS-R unit has been reported an error in EEPROM#1. This EEPROM section should not be used for any SCS memory operations. However, since no OBSW or data is stored in such memory area this has no impact on functionality of SCS-R.

The maximum size of memory load commands allowed is 50 SAUs. Bigger size uploads lead to failure of SCS to accept command and eventual switch-off of SCS by OBCP from 1553 FDIR on TFh TC = SCS RT \"SICK TC\".

TC memory upload rate of 1 Hz (one TC per second) is ok.

IMPORTANT:

HEALTHCHECK Step1, LPSB H7 Sustain Heater Test, is performed by using power value 0x48 POWER_LPSB and NOT H7 max power.

0x48 POWER_LPSB should always be set higher than 1 W to have a successful HealthCheck step#1.



SOFTWARE						
Pos	Parameter Name	Description	Engineering Value			Notes
			bit	SCS-Nom Flight	SCS-Red Flight	
0x00	SW_AUTO_FUNCTIONS Autonomous functions that can be enabled or disabled	Boot Mode ASW Transfer EEPROM→RAM	0	0	0	N/A
		Boot Auto Hardware Tests	1	1	1	N/A
		ASW Auto Hardware Tests	2	1	1	N/A
		Run Diagnostic Sorption Cooler	3	1	1	N/A
		Run Diagnostic Electronics	4	1	1	N/A
		Run Diagnostic Bad Heaters	5	1	1	N/A
		Run Diagnostic Bad ADC	6	1	1	N/A
		Run Diagnostic Bad Sensors	7	1	1	N/A
		Auto GoTo Startup	8	1	1	N/A
		Auto GoTo Defrost	9	0	0	N/A
		Auto GoTo Off-Normal	10	1	1	N/A
		TSA PID Regulation Enable	11	0	0	N/A
		OPEN LOOP Enable	12	0	0	N/A
0x01	SW_ASW_ADR	Base address of the applicative software to use		8005000	8005000	Hex
0x02	SW_CHECKSUM_1_ADR	Base address of the eeprom 1 checksums		8003000	8003000	Hex
0x03	SW_CHECKSUM_N_ADR	Base address of the eeprom n checksums		8007000	8007000	Hex
0x04	SW_TEST_EXT_TIMER_LENGTH	Test external timers duration		1	1	s
0x05	SW_TEST_FPGA_TIMER_LENGTH	Test fpga timer duration		62.5	62.5	ns
0x06	SENSORS_MEAN_T	Number of read to average sensor T1		30	30	decimal
0x07	SENSORS_MEAN_T+1	Number of read to average sensor T2		30	30	decimal
0x08	SENSORS_MEAN_T+2	Number of read to average sensor T3		30	30	decimal
0x09	SENSORS_MEAN_T+3	Number of read to average sensor T4		30	30	decimal
0x0A	SENSORS_MEAN_T+4	Number of read to average sensor T5		30	30	decimal
0x0B	SENSORS_MEAN_T+5	Number of read to average sensor T6		30	30	decimal
0x0C	SENSORS_MEAN_T+6	Number of read to average sensor T7		30	30	decimal



Planck LFI
Sorption Cooler System
User Manual

Document No.: PL-LFI-PST-MA-002
Issue/Rev. No.: 3.0
Date: 20 March 2009

0x0D	SENSORS_MEAN_T+7	Number of read to average sensor T8	30	30	decimal
0x0E	SENSORS_MEAN_T+8	Number of read to average sensor T9	30	30	decimal
0x0F	SENSORS_MEAN_T+9	Number of read to average sensor T10	30	30	decimal
0x10	SENSORS_MEAN_T+10	Number of read to average sensor T11	30	30	decimal
0x11	SENSORS_MEAN_T+11	Number of read to average sensor T12	30	30	decimal
0x12	SENSORS_MEAN_T+12	Number of read to average sensor T13	30	30	decimal
0x13	SENSORS_MEAN_T+13	Number of read to average sensor T14	30	30	decimal
0x14	SENSORS_MEAN_T+14	Number of read to average sensor T15	30	30	decimal
0x15	SENSORS_MEAN_T+15	Number of read to average sensor T16	30	30	decimal
0x16	SENSORS_MEAN_T+16	Number of read to average sensor T17	30	30	decimal
0x17	SENSORS_MEAN_T+17	Number of read to average sensor T18	30	30	decimal
0x18	SENSORS_MEAN_T+18	Number of read to average sensor T20	30	30	decimal
0x19	SENSORS_MEAN_T+19	Number of read to average sensor T21	30	30	decimal
0x1A	SENSORS_MEAN_T+20	Number of read to average sensor T22	30	30	decimal
0x1B	SENSORS_MEAN_T+21	Number of read to average sensor T23	30	30	decimal
0x1C	SENSORS_MEAN_T+22	Number of read to average sensor T24	30	30	decimal
0x1D	SENSORS_MEAN_T+23	Number of read to average sensor T25	30	30	decimal
0x1E	SENSORS_MEAN_T+24	Number of read to average sensor T26	30	30	decimal
0x1F	SENSORS_MEAN_T+25	Number of read to average sensor T27	30	30	decimal
0x20	SENSORS_MEAN_T+26	Number of read to average sensor T28	30	30	decimal
0x21	SENSORS_MEAN_T+27	Number of read to average sensor T29	30	30	decimal
0x22	SENSORS_MEAN_T+28	Number of read to average sensor T30	30	30	decimal
0x23	SENSORS_MEAN_P	Number of read to average sensor P1	30	30	decimal
0x24	SENSORS_MEAN_P+1	Number of read to average sensor P2	30	30	decimal
0x25	SENSORS_MEAN_P+2	Number of read to average sensor P3	30	30	decimal
0x26	SENSORS_MEAN_P+3	Number of read to average sensor P4	30	30	decimal
0x27	SENSORS_MEAN_P+4	Number of read to average sensor P5	30	30	decimal
0x28	SENSORS_MEAN_P+5	Number of read to average sensor P6	30	30	decimal



0x29	SENSORS_MEAN_P+6	Number of read to average sensor P7		30	30	decimal	
0x2A	SENSORS_MEAN_P+7	Number of read to average sensor P8		30	30	decimal	
0x2B	SENSORS_MEAN_TEST	Number of read to average sensor VGAIN		30	30	decimal	
0x2C	SENSORS_MEAN_TEST+1	Number of read to average sensor VOFF		30	30	decimal	
0x2D	SENSORS_MEAN_TEST+2	Number of read to average sensor CAL1		30	30	decimal	
0x2E	SENSORS_MEAN_TEST+3	Number of read to average sensor CAL2		30	30	decimal	
0x2F	SENSORS_TRESEHOLD	Used for software averaged sensors : the first 'tresehold' values will not be taken into account		5	5	decimal	



POWER AND TIMES

Pos	Parameter Name	Description	Engineering Values			Notes
			SCS-Nom Flight	SCS-Red Flight	Units	
0x30	POWER_HEATUP_BEDS	Bed 0 Heatup power for normal operation	100	134	W	
0x31	POWER_HEATUP_BEDS+1	Bed 1 Heatup power for normal operation	100	134	W	
0x32	POWER_HEATUP_BEDS+2	Bed 2 Heatup power for normal operation	100	134	W	
0x33	POWER_HEATUP_BEDS+3	Bed 3 Heatup power for normal operation	100	134	W	
0x34	POWER_HEATUP_BEDS+4	Bed 4 Heatup power for normal operation	100	134	W	
0x35	POWER_HEATUP_BEDS+5	Bed 5 Heatup power for normal operation	100	134	W	
0x36	POWER_DESORB_BED	Bed 0 Desorb power for normal operation	160	130	W	
0x37	POWER_DESORB_BED+1	Bed 1 Desorb power for normal operation	160	130	W	
0x38	POWER_DESORB_BED+2	Bed 2 Desorb power for normal operation	160	130	W	
0x39	POWER_DESORB_BED+3	Bed 3 Desorb power for normal operation	160	130	W	
0x3A	POWER_DESORB_BED+4	Bed 4 Desorb power for normal operation	160	130	W	
0x3B	POWER_DESORB_BED+5	Bed 5 Desorb power for normal operation	160	130	W	
0x3C	POWER_HEATUP_BEDS_STARTUP	Bed 0 Heatup power for startup operation	100	134	W	
0x3D	POWER_HEATUP_BEDS_STARTUP+1	Bed 1 Heatup power for startup operation	100	134	W	
0x3E	POWER_HEATUP_BEDS_STARTUP+2	Bed 2 Heatup power for startup operation	100	134	W	
0x3F	POWER_HEATUP_BEDS_STARTUP+3	Bed 3 Heatup power for startup operation	100	134	W	
0x40	POWER_HEATUP_BEDS_STARTUP+4	Bed 4 Heatup power for startup operation	100	134	W	
0x41	POWER_HEATUP_BEDS_STARTUP+5	Bed 5 Heatup power for startup operation	100	134	W	
0x42	POWER_DESORB_BEDS_STARTUP	Bed 0 Desorb power for startup operation	160	130	W	



0x43	POWER_DESORB_BEDS_STARTUP+1	Bed 1 Desorb power for startup operation	160	130	W	
0x44	POWER_DESORB_BEDS_STARTUP+2	Bed 2 Desorb power for startup operation	160	130	W	
0x45	POWER_DESORB_BEDS_STARTUP+3	Bed 3 Desorb power for startup operation	160	130	W	
0x46	POWER_DESORB_BEDS_STARTUP+4	Bed 4 Desorb power for startup operation	160	130	W	
0x47	POWER_DESORB_BEDS_STARTUP+5	Bed 5 Desorb power for startup operation	160	130	W	
0x48	POWER_LPSB	Low Pressure Stabilization Bed Power	1.35	1.35	W	
0x49	TIME_CYCLE_NORMAL	Cycle Time in Normal Mode	1050	940	s	
0x4A	TIME_GASGAP_ON_BEDS	Time delay for GGA switch ON	0	0	s	
0x4B	TIME_GASGAP_ON_BEDS+1	Time delay for GGA switch ON	0	0	s	
0x4C	TIME_GASGAP_ON_BEDS+2	Time delay for GGA switch ON	0	0	s	
0x4D	TIME_GASGAP_ON_BEDS+3	Time delay for GGA switch ON	0	0	s	
0x4E	TIME_GASGAP_ON_BEDS+4	Time delay for GGA switch ON	0	0	s	
0x4F	TIME_GASGAP_ON_BEDS+5	Time delay for GGA switch ON	0	0	s	
0x50	TIME_GASGAP_OFF_BEDS	Anticipated GGA switch OFF Time	60	60	s	
0x51	TIME_GASGAP_OFF_BEDS+1	Anticipated GGA switch OFF Time	60	60	s	
0x52	TIME_GASGAP_OFF_BEDS+2	Anticipated GGA switch OFF Time	60	60	s	
0x53	TIME_GASGAP_OFF_BEDS+3	Anticipated GGA switch OFF Time	60	60	s	
0x54	TIME_GASGAP_OFF_BEDS+4	Anticipated GGA switch OFF Time	60	60	s	
0x55	TIME_GASGAP_OFF_BEDS+5	Anticipated GGA switch OFF Time	60	60	s	

IMPORTANT:

HEALTHCHECK Step1, LPSB H7 Sustain Heater Test, is performed by using power value 0x48 POWER_LPSB and NOT H7 max power. 0x48 POWER_LPSB should always be set higher than 1 W to have a successful HealthCheck step#1.



HEALTHCHECK REGENERATION						
Pos	Parameter Name	Description	Engineering Values		Units	Notes
			Flight Cold HC			
			SCS-N	SCS-R		
0x56	HEALTHCHECK_DELTA_P_LP	Delta pressure low pressure	0.001	0.001	bar	
0x57	HEALTHCHECK_TIME_LIMIT	Health check time out	120	120	s	
0x58	HEALTHCHECK_TLPSB	LPSB temperature limit	***	***	K	
0x59	HEALTHCHECK_MAX_POWER	Maximum Power	130	130	W	
0x5A	HEALTHCHECK_MIN_POWER	Minimum Power	5	5	W	
0x5B	HEALTHCHECK_TBED_LIMIT	Bed temperature limit	305	305	K	
0x5C	HEALTHCHECK_PBED_LIMIT	Bed pressure limit	1.38	1.38	bar	
0x5D	HEALTHCHECK_DELTAT_COLD	Delta temperature cold	0.5	0.5	K	
0x5E	HEALTHCHECK_TIME_LIMIT_COLD	Cold End Heaters Time-out	2	2	s	
0x5F	REGENERATION_POWER	CE heater power to run the regeneration procedure	150	150	W	
0x60	REGENERATION_TEMPERATURE	T to be maintained for the regeneration process	350	350	K	
0x61	REGENERATION_MAX_PRESSURE	Max P in HPST not to be exceeded	5	5	bar	
0x62	REGENERATION_TIME	Time needed to maintain the CE at REGEN_TEMPERATURE to complete the regeneration process	180	180	s	
0x63	REGENERATION_MAX_TIME	Maximum time allowed during a regeneration process	72000	72000	s	
0x64	REGENERATION_GGON_TEMPERATURE	Max CE T that allows the GGA to be turned ON	320	320	K	
0x65	REGENERATION_DELTAT	set bang-bang level	2	2	K	

*** LPSB T limit parameter (HEALTHCHECK_TLPSB) must be set to T17 + 0.5K **just before** executing the test

IMPORTANT:

HEALTHCHECK Step1, LPSB H7 Sustain Heater Test, is performed by using power value 0x48 POWER_LPSB and NOT H7 max power. 0x48 POWER_LPSB should always be set higher than 1 W to have a successful HealthCheck step#1.



RUN MODE TRANSITION

Pos	Parameter Name	Description	Engineering Values			Notes
			SCS-Nom Flight	SCS-Red Flight	Units	
0x66	STARTUP_TIME_ADJUST_MDP	Conditioning Maximum Desorption Pressure	34.5	34.5	bar	
0x67	STARTUP_TIME_ADJUST_MDT	Maximum Desorbing temperature	460	460	K	
0x68	STARTUP_TIME_ADJUST_MHT	Maximum Heatup Temperature	420	420	K	
0x69	STARTUP_TIME_ADJUST_MCTFIRST	Maximum cycle time (first cycle)	390	390	s	
0x6A	STARTUP_TIME_ADJUST_MCTNEXT	Maximum cycle time (next cycles)	1200	1200	s	
0x6B	STARTUP_ENTER_DEFROST_MTP	Maximum Tank Pressure	54	54	bar	
0x6C	STARTUP_ENTER_DEFROST_MJT_T7	Maximum JT Temperature (using T7)	100	100	K	
0x6D	STARTUP_ENTER_DEFROST_MJT_T30	Maximum JT Temperature (using T30)	100	100	K	
0x6E	STARTUP_ENTER_DEFROST_FLOW	Condition to enter in defrost : Flow Expected	65535	65535	decimal	
0x6F	STARTUP_EXIT_DEFROST_TIME	Defrost Time out (maximum defrost duration)	1000	1000	s	
0x70	STARTUP_EXIT_DEFROST_MJT_T7	Exit Defrost Condition (using T7)	80	80	K	
0x71	STARTUP_EXIT_DEFROST_MJT_T30	Exit Defrost Condition (using T30)	80	80	K	
0x72	STARTUP_ENTER_NORMAL_MCONJT_T7	Maximum startup JT Temperature (using T7)	22	22	K	
0x73	STARTUP_ENTER_NORMAL_MCONJT_T30	Maximum startup JT Temperature (using T30)	22	22	K	
0x74	STARTUP_ENTER_NORMAL_MINCONJT	Minimum Tank Pressure In Startup operation	27.3	28.3	bar	
0x75	STARTUP_ENTER_NORMAL_MAXCONJT	Maximum Tank Pressure In Startup operation	35.5	36.5	bar	
0x76	NORMAL_ENTER_STARTUP_MINNTP	Minimum Tank Pressure in Normal operation	25.5	26.5	bar	
0x77	NORMAL_ENTER_STARTUP_MAXNTP	Maximum Tank Pressure in Normal operation	36.2	37.2	bar	
0x78	NORMAL_ENTER_STARTUP_MNCET	Maximum Normal compressor element temperature	480	480	K	
0x79	NORMAL_ENTER_STARTUP_MNJT_T7	Maximum normal JT Temperature (using T7)	23	23	K	
0x7A	NORMAL_ENTER_STARTUP_MNJT_T30	Maximum normal JT Temperature (using T30)	23	23	K	
0x7B	STARTUP_LPSB_HIGH_TEMPERATURE_LIMIT	LPSB 'bang bang' procedure higher limit	296	296	K	
0x7C	STARTUP_LPSB_LOW_TEMPERATURE_LIMIT	LPSB 'bang bang' procedure lower limit	295	295	K	
0x7D	STARTUP_HPST_PRESSURE_LIMIT	Startup HPST Pressure Limit	28	28	bar	
0x7E	NORMAL_H8_RATE_IF_H7_BAD	H8 on % when H7 is bad (see FMECA 6.2.4, AD08)	5	5	dec %	



FAULTS

Pos	Parameter Name	Description	Engineering Values			Notes
			SCS-Nom Flight	SCS-Red Flight	Units	
0x7F	FAULT_COND_BED_TEMPERATURE_LIMIT	Fault condition bed temperature limit	525	525	K	
0x80	FAULT_COND_BED_PRESSURE_LIMIT	Fault condition bed pressure limit	54.1	54.1	bar	
0x81	FAULT_COND_LPSB_TEMPERATURE_LIMIT	Fault condition lpsb temperature limit	350	350	K	
0x82	FAULT_COND_PRT_TEMPERATURE_DEFAULT	Default T for PRT sensors in case of failure	270	270	K	
0x83	FAULT_COND_JT_TEMPERATURE_DEFAULT	Default T for JT sensors in case of failure	23	23	K	
0x84	BAD_BED_DETECT_COOL_TEMP_LIMIT	Bad Bed Detection : cooldown bed must be removed if its temperature is higher than this limit	330	330	K	
0x85	BAD_BED_DETECT_COOL_PRESSURE_LIMIT	Bad Bed Detection : cooldown bed must be removed if its pressure is higher than this limit	7.58	7.58	bar	
0x86	BAD_BED_DETECT_HEATUP_TEMP_LIMIT	Bad Bed Detection : heatup bed must be removed if its temperature is higher than this limit	330	330	K	
0x87	BAD_BED_DETECT_HEATUP_PRESSURE_LIMIT	Bad Bed Detection : heatup bed must be removed if its pressure is higher than this limit	7.58	7.58	bar	
0x88	BAD_BED_DETECT_CYCLE_PERIOD	Bad Bed Detection : Bad Bed Detection is enabled if cycle time is below this limit	390	390	s	
0x89	FAULT_ELECTRONIC_28V_DEFAULT	If 28 volts is wrong use this value to calculate the power	27.5	27.5	V	
0x8a	FAULT_ELECTRONIC_28V_UP_LIMIT	If 28 volts is greater than this value, 28 volts is wrong	32	32	V	
0x8b	FAULT_ELECTRONIC_28V_LOW_LIMIT	If 28 volts is lower than this value, 28 volts is wrong	25	25	V	
0x8c	FAULT_ELECTRONIC_12V_UP_LIMIT	If 12 volts is greater than this value, 12 volts is wrong	13	13	V	
0x8d	FAULT_ELECTRONIC_12V_LOW_LIMIT	If 12 volts is lower than this value, 12 volts is wrong	11	11	V	
0x8e	FAULT_ELECTRONIC_12V_TIME	See FMECA 6.3.2 [AD08]	120	120	s	
0x8f	FAULT_ELECTRONIC_TEMP_FIRST	See FMECA 6.3.1 [AD08]	333	333	K	



0x90	FAULT_ELECTRONIC_TEMP_SECOND	See FMECA 6.3.1 [AD08]	353	353	K	
0x91	FAULT_ELECTRONIC_ADC_REF	Digital output from reference sensor shall be compared to this value + - delta	60800	60800	decimal	
0x92	FAULT_ELECTRONIC_ADC_DELTA	Digital output from reference sensor shall be compared to reference value +- this parameter	250	250	decimal	
0x93	FAULT_HEATERS_H2I_ON	Gas Gaps current must be up this limit when active	0.5	0.5	A	
0x94	FAULT_HEATERS_H2I_OFF	Gas Gap current must be lower than this limit when inactive	0.1	0.1	A	
0x95	FAULT_HEATERS_H7	I measured on H7 must be equal to I applied (from DAC value) \pm this parameter	0.1	0.1	A	
0x96	FAULT_HEATERS_H31	I measured on H31/H32 must be equal to I applied (from DAC value) \pm this parameter	0.1	0.1	A	
0x97	FAULT_HEATERS_H8	If T17 and T18 temperature are above this limit, H8 is always on (Failure from FDIR)	320	320	K	
0x98	FAULT_HEATERS_H34_H35_T_UP_T7	H33/H34 bad if JT temperature up this limit (using T7)	110	110	K	
0x99	FAULT_HEATERS_H34_H35_T_UP_T30	H33/H34 bad if JT temperature up this limit (using T30)	110	110	K	
0x9a	FAULT_HEATERS_H34_H35_DELTA_T	H33/H34 bad if this value is not reached within 'rise time'	25	25	K	
0x9b	FAULT_HEATERS_H34_H35_RISE_TIME	H33/H34 bad if 'delta T' is not reached within this time value	180	180	s	



PID

Pos	Parameter Name	Description	Engineering Values			Notes
			SCS-Nom Flight	SCS-Red Flight	Units	
0x9c	PID_SETPOINT_T5	Set Point of the L3 PID regulator (using T5)	18.05	18.05	K	
0x9d	PID_SETPOINT_T6	Set Point of the L3 PID regulator (using T6)	18.05	18.05	K	
0x9e	PID_P	P parameter of the L3 PID regulator	500	500	decimal	
0x9f	PID_I	I parameter of the L3 PID regulator	15	15	decimal	
0xa0	PID_D	D parameter of the L3 PID regulator	0	0	decimal	
0xa1	PID_RATE	Sampling rate of the L3 PID regulator	1	1	s	
0xa2	PID_UPPER_LIMIT	Upper Limit of the L3 PID regulator	22	22	V	
0xa3	PID_LOWER_LIMIT	Lower Limit of the L3 PID regulator	0	0	V	
0xa4	PID_TEMPERATURE_LIMIT_T5	Temperature Limit of the L3 PID regulator (using T5)	22	22	K	
0xa5	PID_TEMPERATURE_LIMIT_T6	Temperature Limit of the L3 PID regulator (using T6)	22	22	K	
0xa6	OPEN_LOOP_R1	R1 value from the open loop algorithm	1.63	1.63	K/W	Thermal R
0xa7	OPEN_LOOP_N	Number of previous Q_LFI value to average from open loop	60	60	decimal	



RESISTORS

Pos	Parameter Name	Description	Engineering Values		Units	Notes
			SCS-Nom Flight	SCS-Red Flight		
0xa8	HW_HEATERS_RB	Loss resistor 'rb' for bed 0 power calculation	5.01	5.00	Ω	
0xa9	HW_HEATERS_RB+1	Loss resistor 'rb' for bed 1 power calculation	4.99	5.00	Ω	
0xaa	HW_HEATERS_RB+2	Loss resistor 'rb' for bed 2 power calculation	4.98	5.10	Ω	
0xab	HW_HEATERS_RB+3	Loss resistor 'rb' for bed 3 power calculation	5.10	5.00	Ω	
0xac	HW_HEATERS_RB+4	Loss resistor 'rb' for bed 4 power calculation	4.94	5.00	Ω	
0xad	HW_HEATERS_RB+5	Loss resistor 'rb' for bed 5 power calculation	5.04	4.90	Ω	
0xae	HW_HEATERS_RBL	Loss resistor 'rbl' for bed 0 power calculation	5.11	5.10	Ω	
0xaf	HW_HEATERS_RBL+1	Loss resistor 'rbl' for bed 1 power calculation	5.09	5.10	Ω	
0xb0	HW_HEATERS_RBL+2	Loss resistor 'rbl' for bed 2 power calculation	5.08	5.20	Ω	
0xb1	HW_HEATERS_RBL+3	Loss resistor 'rbl' for bed 3 power calculation	5.20	5.10	Ω	
0xb2	HW_HEATERS_RBL+4	Loss resistor 'rbl' for bed 4 power calculation	5.04	5.10	Ω	
0xb3	HW_HEATERS_RBL+5	Loss resistor 'rbl' for bed 5 power calculation	5.14	5.00	Ω	
0xb4	HW_HEATERS_RV	Loss resistor 'rv' for bed 0 power calculation	5.38	5.40	Ω	
0xb5	HW_HEATERS_RV+1	Loss resistor 'rv' for bed 1 power calculation	5.30	5.40	Ω	
0xb6	HW_HEATERS_RV+2	Loss resistor 'rv' for bed 2 power calculation	5.37	5.40	Ω	
0xb7	HW_HEATERS_RV+3	Loss resistor 'rv' for bed 3 power calculation	5.43	5.20	Ω	
0xb8	HW_HEATERS_RV+4	Loss resistor 'rv' for bed 4 power calculation	5.30	5.40	Ω	
0xb9	HW_HEATERS_RV+5	Loss resistor 'rv' for bed 5 power calculation	5.43	5.30	Ω	
0xba	HW_HEATERS_RVL	Loss resistor 'rvl' for bed 0 power calculation	5.48	5.50	Ω	
0xbb	HW_HEATERS_RVL+1	Loss resistor 'rvl' for bed 1 power calculation	5.40	5.50	Ω	
0xbc	HW_HEATERS_RVL+2	Loss resistor 'rvl' for bed 2 power calculation	5.47	5.50	Ω	
0xbd	HW_HEATERS_RVL+3	Loss resistor 'rvl' for bed 3 power calculation	5.53	5.30	Ω	
0xbe	HW_HEATERS_RVL+4	Loss resistor 'rvl' for bed 4 power calculation	5.40	5.50	Ω	



0xbf	HW_HEATERS_RVL+5	Loss resistor 'rvl' for bed 5 power calculation	5.53	5.40	Ω	
0xc0	HW_HEATERS_RH7	H7 resistor for LPSB power H7 calculation	32.60	32.60	Ω	
0xc1	HW_HEATERS_RH31	H31 resistor for LR3 (nom) power calculation	488.00	488.00	Ω	
0xc2	HW_HEATERS_RH32	H32 resistor for LR3 (red) power calculation	488.00	488.00	Ω	



CALIBRATION 1

Pos	Parameter Name	Description	Engineering Values		Units	Notes
			SCS-Nom Flight	SCS-Red Flight		
0xc3	HW_CAL_ADC_V31	Calibration ADC to volts for 31 volts	1310.7	1310.7	decimal	
0xc4	HW_CAL_ADC_V28	Calibration ADC to volts for 28 volts	2184.5	2184.5	decimal	
0xc5	HW_CAL_ADC_V12	Calibration ADC to volts for 12 volts	3276.75	3276.75	decimal	
0xc6	HW_CAL_GAIN_H7	GAINh7 part of Ih7 = GAINh7 + OFFSETh7	0.9736	0.9736	decimal	
0xc7	HW_CAL_OFFSET_H7	OFFSETh7 part of Ih7 = GAINh7 + OFFSETh7	0	0	decimal	
0xc8	HW_CAL_GAIN_H31	GAINh31 part of Ih31 = GAINh31 + OFFSETh31	0.0812	0.0812	decimal	
0xc9	HW_CAL_OFFSET_H31	OFFSETh31 part of Ih31 = GAINh31 + OFFSETh31	0	0	decimal	
0xca	HW_CAL_GAIN_H32	GAINh32 part of Ih32 = GAINh32 + OFFSETh32	0.0812	0.0812	decimal	
0xcb	HW_CAL_OFFSET_H32	OFFSETh32 part of Ih32 = GAINh32 + OFFSETh32	0	0	decimal	
0xcc	HW_CAL_T3_R0	T3(ADC) → T3(K). Resistance = T3(ADC) * R0 / 65535 + R1	4400.51	4418.24	decimal	
0xcd	HW_CAL_T3_R1	T3(ADC) → T3(K). Resistance = T3(ADC) * R0 / 65535 + R1	121.57	122.32	decimal	
0xce	HW_CAL_T3_ZL	T3(ADC) → T3(K). Chebychev ZL coefficient	3.067725563	2.907696155	decimal	
0xcf	HW_CAL_T3_ZU	T3(ADC) → T3(K). Chebychev ZU coefficient	4.358324119	4.03298032	decimal	
0xd0	HW_CAL_T3_A0	T3(ADC) → T3(K). Chebychev A0 coefficient	11.918839	11.962971	decimal	
0xd1	HW_CAL_T3_A1	T3(ADC) → T3(K). Chebychev A1 coefficient	-11.124553	-11.194584	decimal	
0xd2	HW_CAL_T3_A2	T3(ADC) → T3(K). Chebychev A2 coefficient	3.48778	3.515801	decimal	
0xd3	HW_CAL_T3_A3	T3(ADC) → T3(K). Chebychev A3 coefficient	-0.782669	-0.783545	decimal	
0xd4	HW_CAL_T3_A4	T3(ADC) → T3(K). Chebychev A4 coefficient	0.119087	0.113076	decimal	
0xd5	HW_CAL_T3_A5	T3(ADC) → T3(K). Chebychev A5 coefficient	-0.010445	-0.006186	decimal	



0xd6	HW_CAL_T4_R0	$T4(ADC) \rightarrow T4(K)$. Resistance = $T4(ADC) * R0 / 65535 + R1$	4401.31	4417.24	decimal	
0xd7	HW_CAL_T4_R1	$T4(ADC) \rightarrow T4(K)$. Resistance = $T4(ADC) * R0 / 65535 + R1$	121.69	122.35	decimal	
0xd8	HW_CAL_T4_ZL	$T4(ADC) \rightarrow T4(K)$. Chebychev ZL coefficient	2.842756794	2.76194118	decimal	
0xd9	HW_CAL_T4_ZU	$T4(ADC) \rightarrow T4(K)$. Chebychev ZU coefficient	3.93386007	3.938180357	decimal	
0xda	HW_CAL_T4_A0	$T4(ADC) \rightarrow T4(K)$. Chebychev A0 coefficient	11.929172	11.837288	decimal	
0xdb	HW_CAL_T4_A1	$T4(ADC) \rightarrow T4(K)$. Chebychev A1 coefficient	-11.28089	-11.036423	decimal	
0xdc	HW_CAL_T4_A2	$T4(ADC) \rightarrow T4(K)$. Chebychev A2 coefficient	3.512276	3.529423	decimal	
0xdd	HW_CAL_T4_A3	$T4(ADC) \rightarrow T4(K)$. Chebychev A3 coefficient	-0.758478	-0.86858	decimal	
0xde	HW_CAL_T4_A4	$T4(ADC) \rightarrow T4(K)$. Chebychev A4 coefficient	0.102641	0.169652	decimal	
0xdf	HW_CAL_T4_A5	$T4(ADC) \rightarrow T4(K)$. Chebychev A5 coefficient	-0.004946	-0.026502	decimal	
0xe0	HW_CAL_T4_A6	$T4(ADC) \rightarrow T4(K)$. Chebychev A6 coefficient	0	0.003555	decimal	



Calibration 2

Pos	Parameter Name	Description	Engineering Values		Units	Notes
			SCS-Nom Flight	SCS-Red Flight		
0xe1	HW_CAL_T5_R0	$T5(ADC) \rightarrow T5(K). Resistance = T5(ADC) * R0 / 65535 + R1$	1758.53	1764.12	decimal	
0xe2	HW_CAL_T5_R1	$T5(ADC) \rightarrow T5(K). Resistance = T5(ADC) * R0 / 65535 + R1$	665.49	665.29	decimal	
0xe3	HW_CAL_T5_ZL	T5(ADC) \rightarrow T5(K). Chebychev ZL coefficient	2.855945561	2.822024226	decimal	
0xe4	HW_CAL_T5_ZU	T5(ADC) \rightarrow T5(K). Chebychev ZU coefficient	3.963267678	3.759289252	decimal	
0xe5	HW_CAL_T5_A0	T5(ADC) \rightarrow T5(K). Chebychev A0 coefficient	11.918305	11.86822	decimal	
0xe6	HW_CAL_T5_A1	T5(ADC) \rightarrow T5(K). Chebychev A1 coefficient	-11.274393	-11.125414	decimal	
0xe7	HW_CAL_T5_A2	T5(ADC) \rightarrow T5(K). Chebychev A2 coefficient	3.521261	3.568656	decimal	
0xe8	HW_CAL_T5_A3	T5(ADC) \rightarrow T5(K). Chebychev A3 coefficient	-0.765057	-0.809943	decimal	
0xe9	HW_CAL_T5_A4	T5(ADC) \rightarrow T5(K). Chebychev A4 coefficient	0.1047	0.107181	decimal	
0xea	HW_CAL_T5_A5	T5(ADC) \rightarrow T5(K). Chebychev A5 coefficient	-0.004926	0.003469	decimal	
0xeb	HW_CAL_T5_A6	T5(ADC) \rightarrow T5(K). Chebychev A6 coefficient	0	-0.004578	decimal	
0xec	HW_CAL_T5_A7	T5(ADC) \rightarrow T5(K). Chebychev A7 coefficient	0	0.000383	decimal	
0xed	HW_CAL_T6_R0	$T6(ADC) \rightarrow T6(K). Resistance = T6(ADC) * R0 / 65535 + R1$	1758.6	1765.74	decimal	
0xee	HW_CAL_T6_R1	$T6(ADC) \rightarrow T6(K). Resistance = T6(ADC) * R0 / 65535 + R1$	665.34	665.51	decimal	
0xef	HW_CAL_T6_ZL	T6(ADC) \rightarrow T6(K). Chebychev ZL coefficient	3.093303734	2.995075652	decimal	
0xf0	HW_CAL_T6_ZU	T6(ADC) \rightarrow T6(K). Chebychev ZU coefficient	4.461153937	4.313704991	decimal	
0xf1	HW_CAL_T6_A0	T6(ADC) \rightarrow T6(K). Chebychev A0 coefficient	11.793828	11.714016	decimal	
0xf2	HW_CAL_T6_A1	T6(ADC) \rightarrow T6(K). Chebychev A1 coefficient	-11.093765	-11.039031	decimal	
0xf3	HW_CAL_T6_A2	T6(ADC) \rightarrow T6(K). Chebychev A2 coefficient	3.667011	3.722686	decimal	



0xf4	HW_CAL_T6_A3	T6(ADC) → T6(K). Chebychev A3 coefficient	-0.916537	-0.938237	decimal
0xf5	HW_CAL_T6_A4	T6(ADC) → T6(K). Chebychev A4 coefficient	0.168287	0.158954	decimal
0xf6	HW_CAL_T6_A5	T6(ADC) → T6(K). Chebychev A5 coefficient	-0.019377	-0.007817	decimal
0xf7	HW_CAL_T6_A6	T6(ADC) → T6(K). Chebychev A6 coefficient	0	-0.00354	decimal
0xf8	HW_CAL_T7_R0	T7(ADC)→T7(K). Resistance=T7(ADC)*R0/65535+R1	4402.4	4423.38	decimal
0xf9	HW_CAL_T7_R1	T7(ADC)→T7(K). Resistance=T7(ADC)*R0/65535+R1	121.66	122.53	decimal
0xfa	HW_CAL_T7_A	T7(K) from T7(ADC). $R=ADC * R0 / 65535 + R1$. $X = \log R$. $T (Kelvin) = \exp(A - B . x)$	9.7955	9.1952	decimal
0xfb	HW_CAL_T7_B	T7(K) from T7(ADC). $R=ADC * R0 / 65535 + BR1$ $X = \log R$. $T (Kelvin) = \exp(A - B . x)$	0.9856	0.824	decimal
0xfc	HW_CAL_T30_R0	T30(ADC) → T30(K). Resistance = T30(ADC) * R0 / 65535 + R1	4398.04	4415.3	decimal
0xfd	HW_CAL_T30_R1	T30(ADC) → T30(K). Resistance = T30(ADC) * R0 / 65535 + R1	121.64	122.36	decimal
0xfe	HW_CAL_T30_A	T30(K) from T3(ADC). $R=ADC * R0 / 65535 + R1$. $X = \log R$. $T (Kelvin) = \exp(A - B . x)$	9.0919	9.2067	decimal
0xff	HW_CAL_T30_B	T30(K) from T3(ADC). $R=ADC * R0 / 65535 + R1$. $X = \log R$. $T (Kelvin) = \exp(A - B . x)$	0.755	0.824	decimal
0x100	HW_CAL_TBED_UVA	UVA term for bed temperature calculation : $uV = t_{Thermocouple} * UVA / 65535 - UVB$	20	20	decimal
0x101	HW_CAL_TBED_UVB	UVB term for bed temperature calculation : $uV = t_{Thermocouple} * UVA / 65535 - UVB$	1.3954	1.3954	decimal
0x102	HW_CAL_TBED_TRA	TRA term for bed temp. calc. $r = t_{ReferenceK} * TRA / 65535 - (t_{ReferenceK} - 65535) * TRB / 65535$	139	139	decimal
0x103	HW_CAL_TBED_TRB	TRB term for bed temp. calc. $r = t_{ReferenceK} * TRA / 65535 - (t_{ReferenceK} - 65535) * TRB / 65535$	78.8	78.8	decimal
0x104	RATE_BED_POWER_ADJUST	Bed heaters power readjustment frequency (number of sensors set between two power adjustment)	3	3	decimal



A2 Appendix 2: SCS Devices (Heaters and Sensors)

A2.1 Devices ID for telecommanding:

Device	Nr. (Hex)	Device	Nr. (Hex)	Device	Nr. (Hex)	Device	Nr. (Hex)	Device	Nr. (Hex)	Device	Nr. (Hex)
ADC 0	0	H24	0xb	H14	0x16	T6	0x105	T17	0x110	T29	0x11b
ADC 1	1	H25	0xc	H15	0x17	T7	0x106	T18	0x111	T30	0x11c
H1	2	H26	0xd	H16	0x18	T8	0x107	T20	0x112	P1	0x200
H2	3	H8	0xe	H7	0x19	T9	0x108	T21	0x113	P2	0x201
H3	4	H33	0xf	H31	0x1a	T10	0x109	T22	0x114	P3	0x202
H4	5	H34	0x10	H32	0x1b	T11	0x10a	T23	0x115	P4	0x203
H5	6	H35	0x11	T1	0x100	T12	0x10b	T24	0x116	P5	0x204
H6	7	H36	0x12	T2	0x101	T13	0x10c	T25	0x117	P6	0x205
H21	8	H11	0x13	T3	0x102	T14	0x10d	T26	0x118	P7	0x206
H22	9	H12	0x14	T4	0x103	T15	0x10e	T27	0x119	P8	0x207
H23	0xa	H13	0x15	T5	0x104	T16	0x10f	T28	0x11a		

Table A2- 1

Note:

- Devices from 0x000 to 0x0ff are heaters and ADC.
- Devices from 0x100 to 0x1ff are temperature sensors
- Devices from 0x200 to 0x2ff are pressure sensors

A2.2 List of Sensors

Item	Location	Function	Type	Nominal / Redundant / Single	Parameter name in the MIB	Calibration curve type	Calibration type condition 0 = no condition 1 = cooler + electronics 2 = cooler only
T1	LVHX1	Temperature	Cernox	Nominal to T2	SM018540	Numerical	1
T2	LVHX1	Temperature	Cernox	Redundant to T1	SM074540		
T3	LVHX2	Temperature	Cernox	Nominal to T4	SM019540		
T4	LVHX2	Temperature	Cernox	Redundant to T3	SM075540		
T5	TSA	Temperature	Cernox	Nominal to T6	SM020540		
T6	TSA	Temperature	Cernox	Redundant to T5	SM076540		
T7	JT	Temperature	Cernox	Nominal to T30	SM021540		
T8	PC3C	Temperature	Cernox	Single	SM022540		
T9	PC3B	Temperature	Cernox	Single	SM023540		
T10	PC3A	Temperature	Cernox	Single	SM024540		
T11	PC2	Temperature	Cernox	Single	SM025540		
T12	PC1	Temperature	Cernox	Single	SM026540		
T13	HPST1	Temperature	Prt	Single	SM027540		
T14	HPST2	Temperature	Prt	Single	SM028540		
T15	CE1 Outer Shell	Temperature	Prt	Single	SM029540		
T16	CE2 Outer Shell	Temperature	Prt	Single	SM030540		
T17	LPSB	Temperature	Prt	Single	SM031540		
T18	LPSB	Temperature	Prt	Single	SM032540		
T20	CE1 Inner T	Temperature	Ktc	Single	SM034540	The same numerical one	0
T21	CE2 Inner T	Temperature	Ktc	Single	SM035540		
T22	CE3 Inner T	Temperature	Ktc	Single	SM036540		
T23	CE4 Inner T	Temperature	Ktc	Single	SM037540		
T24	CE5 Inner T	Temperature	Ktc	Single	SM038540		
T25	CE6 Inner T	Temperature	Ktc	Single	SM039540	Numerical	1
T26	CE3 Outer Shell	Temperature	Prt	Single	SM040540		
T27	CE4 Outer Shell	Temperature	Prt	Single	SM041540		



T28	CE5 Outer Shell	Temperature	Prt	Single	SM042540		
T29	CE6 Outer Shell	Temperature	Prt	Single	SM043540		
T30	J-T	Temperature	Cernox	Redundant to T7	SM077540		
P1	CE1 Inner P	Pressure	Press.	Single	SM044540	Numerical (with only 2 points)	2
P2	CE2 Inner P	Pressure	Press	Single	SM045540		
P3	CE3 Inner P	Pressure	Press	Single	SM046540		
P4	CE4 Inner P	Pressure	Press	Single	SM047540		
P5	CE5 Inner P	Pressure	Press	Single	SM048540		
P6	CE6 Inner P	Pressure	Press	Single	SM049540		
P7	HPST P	Pressure	Press	Single	SM050540		
P8	LPSB P	Pressure	Press	Single	SM051540		
U1	SCE After the 28V converter	Voltage		Single	SM052540	Polynomial	0
U2	SCE After the 12V converter	Voltage		Single	SM053540		
U3	SCE After the 5V converter	Voltage		Single	SM054540		
U4	SCE After the +12V converter	Voltage		Single	SM055540		
U5	SCE After the -12V converter	Voltage		Single	SM056540		
U6	SCE tension 31V	Voltage		Single	SM101540		
I1	SCE current LPSB H7	Intensity		Single	SM058540		
I2	SCC courant H21	Intensity		Single	SM059540		
I3	SCC courant H22	Intensity		Single	SM060540		
I4	SCC courant H23	Intensity		Single	SM061540		
I5	SCC courant H24	Intensity		Single	SM062540		
I6	SCC courant H25	Intensity		Single	SM063540		
I7	SCCcourant H26	Intensity		Single	SM064540		
I8	SCC courant H31	Intensity		Single	SM065540		
I9	SCC courant H32	Intensity		Single	SM066540		
TE1	SCE Cold Face	SCE Temperature		Single	SM071540	The same numerical one (with only 2 points)	0
TE2	SCE Warmest part of PCB	SCE Temperature		Single	SM072540		
TE3	SCE Warm face	SCE Temperature		Single	SM073540		
CAL1	Test	Calibration		Single	SM069540	N/A	
CAL2	Test	Calibration		Single	SM070540		
VGAIN	Test	Voltage		Single	SM067540		
VOFF	Test	Voltage		Single	SM068540		

Table A2- 2: List of Sensors



A2.3 List of Heaters

Item	Location	Function	Type (Fixed / Variable)	Nominal / Redundant / Single	Parameter name in MIB	Calibration curve type	Calibration type condition 0 = no condition 1 = cooler + electronics 2 = cooler only
H1	Compr 1	Heat/Desorb Basic	Fixed	Single	N/A		
H11	Compr 1	Heat/Desorb Adjustable	Variable	Single	SM004540	Polynomial p1	0
H21	Compr 1	Thermal Switch	Fixed	Single	N/A		
H2	Compr 2	Heat/Desorb Basic	Fixed	Single	N/A		
H12	Compr 2	Heat/Desorb Adjustable	Variable	Single	SM005540	Polynomial p1	0
H22	Compr 2	Thermal Switch	Fixed	Single	N/A		
H3	Compr 3	Heat/Desorb Basic	Fixed	Single	N/A		
H13	Compr 3	Heat/Desorb Adjustable	Variable	Single	SM006540	Polynomial p1	0
H23	Compr 3	Thermal Switch	Fixed	Single	N/A		
H4	Compr 4	Heat/Desorb Basic	Fixed	Single	N/A		
H14	Compr 4	Heat/Desorb Adjustable	Variable	Single	SM007540	Polynomial p1	0
H24	Compr 4	Thermal Switch	Fixed	Single	N/A		
H5	Compr 5	Heat/Desorb Basic	Fixed	Single	N/A		
H15	Compr 5	Heat/Desorb Adjustable	Variable	Single	SM008540	Polynomial p1	0
H25	Compr 5	Thermal Switch	Fixed	Single	N/A		
H6	Compr 6	Heat/Desorb Basic	Fixed	Single	N/A		
H16	Compr 6	Heat/Desorb Adjustable	Variable	Single	SM009540	Polynomial p1	0
H26	Compr 6	Thermal Switch	Fixed	Single	N/A		
H7	LPSB	Substain Low P, Adjust	Variable	Single	SM010540	Polynomial p1	0
H8	LPSB	Speed LPSB Startup	Fixed	Single	N/A		
H31	TSA	Stabilizer, Variable	Variable	Nominal to H32	SM011540	The same polynomial one	0
H32	TSA	Stabilizer, Variable	Variable	Redundant to H31	SM012540		
H33	0.01μ filt	Defroster	Fixed	Nominal to H36	N/A		
H34	J-T	Defroster	Fixed	Nominal to H35			
H35	J-T	Defroster	Fixed	Redundant to H34			
H36	0.01μ filt	Defroster	Fixed	Redundant to H33			

Table A2- 3: List of Heaters

For sensing line telemetry IDs and limits see Appendix 3 SCS MIB Par. A3.5.5 (Figure A3-39)



Appendix 3 SCS MIB

This Appendix to the SCS User Manual is an excerpt of LPSC (Grenoble) document:

“Planck Sorption cooler Electronics MIB USER GUIDE”
UM-PSCZ-600092-LPSC, Is.1.5, 4 June 2008

In case of SCS Database update, the new release of this document has to be taken as an annex to this SCS User Manual and used as reference for all Sorption Cooler MIB issues.

A3 Telemetries part

Telemetries described in the MIB are completely described in the “*Planck Sorption Cooler Electronics TC and TM Structures*” document, ref. [AD07].

A3.1 Packets – PID, PIC and TPCF tables

The PID and PIC tables specify the general characteristics of incoming TM packets and the criteria to recognize and uniquely identify them within SCOS-2000. The characteristics of the SCOS-2000 TM Packets are specified in the TPCF table.

A3.1.1 The PID table

A3.1.1.1 General description

This table is used to identify incoming packets and enable their further processing. The structure of the SCOS-2000 TM packets (and thus the way to extract parameters out of them) is uniquely identified by the SCOS-2000 Packet ID (SPID) for fixed packets and by the Telemetry Packet Structure Definition (TPSD) for variable packets.

For the SCE system, available telemetry packets are (ref. [AD07]):

- TM (1, *): telecommand report
- TM (3, 25): housekeeping parameter report
- TM (3, 26): diagnostic parameter report
- TM (5, 1): event report
- TM (5, 2): exception report
- TM(5, 4): error report
- TM(6, 6): memory dump absolute address
- TM(6, 10): memory check report absolute address
- TM(9, 9): time verification report
- TM(14, 4): report enabled telemetry packets
- TM(17, 2): Link connection report

The key to identify a packet is composed by the first 5 fields of the table, i.e. TYPE, STYPE, APID, PI1_VAL and PI2_VAL.

PI1 and PI2 are additional identification fields for each packet type/subtype/APIID combination.

For all Herschel / Planck systems, the following characteristics should be noticed:

- for housekeeping and diagnostic parameter reports PI1 is the SID
- for the service 1 PI1 is the failure code



- for event, exception and error reports PI1 is the Event ID
- PI2 is never used in the SCE system.

The Figure A3-1 is a view of the PID table. Important facts in it are:

- It is allowed to associate different keys to the same SPID. This is done for:
 - o Nominal and redundant version of the same telemetry, as the structure of the packet is exactly the same, only the APID is different
 - o All event reports, as their packet structure is exactly the same (only the "PI1", event ID is different)
 - o Reports failure as the structure of the packet is exactly the same (only the "PI1" is different)
 - o HSK2 (i.e. non essential housekeeping packets) and HSK3 packets (i.e. essential housekeeping packets), as their packet structure is exactly the same (only the "PI1" and SID are different)

Type	SubType	APID	PI1	SPID	Description
1	1	1664	0	190101530	Acceptance Report Success
1	1	1665	0	190101530	Acceptance Report Success R
1	2	1664	0 to 5 and 16 to 22	190102530	Acceptance Report Failure
1	2	1665	0 to 5 and 16 to 22	190102530	Acceptance Report Failure R
1	3	1664	0	190103530	Execution Report Started
1	3	1665	0	190103530	Execution Report Started R
1	7	1664	0	190107530	Execution Report Completed
1	7	1665	0	190107530	Execution Report Completed R
1	8	1664	0 to 5 and 16 to 22	190108530	Execution Report Failure
1	8	1665	0 to 5 and 16 to 22	190108530	Execution Report Failure R
3	25	1664	1	190301530	HSK1 boot software
3	25	1665	1	190301530	HSK1 boot software R
3	25	1666	2	190302559	HSK2 non essential ASW
3	25	1667	2	190302559	HSK2 non essential ASW R
3	25	1664	3	190302559	HSK3 essential ASW
3	25	1665	3	190302559	HSK3 essential ASW R
3	26	1666	1	190311530	Diag1 boot
3	26	1666	2	190312530	Diag2 applicative
3	26	1666	3	190313530	Diag3 health check
3	26	1666	4	190314530	Diag4 Regeneration
3	26	1667	1	190311530	Diag1 boot R
3	26	1667	2	190312530	Diag2 applicative R
3	26	1667	3	190313530	Diag3 health check R
3	26	1667	4	190314530	Diag4 Regeneration R
5	1	1664	1 to 9	190501530	SCE Event Report
5	1	1665	1 to 9	190501530	SCE Event Report R
5	2	1664	10	190502530	SCE Exception Report
5	2	1665	10	190502530	SCE Exception Report R
5	4	1664	11	190504530	SCE Error Report
5	4	1665	11	190504530	SCE Error Report R
6	6	1664	0	190606559	Memory Dump Absolute Add
6	6	1665	0	190606559	Memory Dump Absolute Add R
6	10	1664	0	190610530	Memory Check Absolute Add
6	10	1665	0	190610530	Memory Check Absolute Add R
9	9	1664	0	190900530	Time Verification Report
9	9	1665	0	190900530	Time Verification Report R
14	4	1664	0	191400530	Enabled TM Packet Report



14	4	1665	0	191400530	Enabled TM Packet Report R
17	2	1664	0	191700530	Link Connection Report
17	2	1665	0	191700530	Link Connection Report R

Figure A3-1: Content of the PID table

A3.1.1.2 PID Fields for variable length packets

For service type 14, subtype 4, packets are defined with a variable structure definition, as follows:

Type	SubType	APID	PI1	SPID	Description	TPSD	DFHSIZE
14	4	1664	0	191400530	Enabled TM Packet Report	191400530	7
14	4	1665	0	191400530	Enabled TM Packet Report R	191400530	7

Figure A3-2: Packets with a variable structure definition in the PID table

The PID_TPSD field specifies the SCOS-2000 Telemetry Packet Structure Definition. It is only used by the Variable Packets Display application. It must be set to '-1' for packets which are not defined in the VPD table. It must be set to the packet structure identification number for a packet which is defined in the VPD table.

The PID_DFHSIZE field specifies the start reference for the processing of variable packets with respect to the end of the SCOS -2000 packet header, in number of bytes. This field is irrelevant in case of fixed packets (PID_TPSD= '-1').

In our case, the processing of variable packet begins with the Packet Type from the Data Field Header, so PID_DFHSIZE is 7 bytes.

Telemetry structure from the "Planck Sorption Cooler Electronics OBSW TC and TM Structures" document, ref chapter 10 and [AD07]:

Packet Header (48 bits)							Packet Data Field		
Packet ID				Packet Sequence Control		Packet Length	Data Field Header	Application Data	Packet Error Control
Version Number	Type	Data Field Header Flag	APID	Segmentation Flag	Source Sequence Count				
3 bits	1 bit	1 bit	11 bits	2 bits	14 bits	16 bits	80 bits		16 bits

Figure A3-3: Telemetry packet structure

Data Field Header						
Spare	TM Source Packet PUS Version Number	Spare	Packet Type	Packet Sub type	Spare	Time
1 bit	3 bits	4 bits	8 bits	8 bits	8 bits	48 bits

Start reference for the processing of variable packet

Figure A3-4: Data field header structure



A3.1.1.3 PID Fields for packets sent periodically

Some packets are sent periodically, according to the mode:

Type	SubType	APID	PI1	SPID	Description	TIME (s)
3	25	1664	1	190301530	HSK1 boot software	1000
3	25	1665	1	190301530	HSK1 boot software R	1000
3	25	1666	2	190302559	HSK2 non essential ASW	1000
3	25	1667	2	190302559	HSK2 non essential ASW R	1000
3	25	1664	3	190302559	HSK3 essential ASW	10000
3	25	1665	3	190302559	HSK3 essential ASW R	10000
3	26	1666	3	190313530	Diag3 health check	1000
3	26	1666	4	190314530	Diag4 Regeneration	1000
3	26	1667	3	190313530	Diag3 health check R	1000
3	26	1667	4	190314530	Diag4 Regeneration R	1000

Figure A3-5: Packets sent periodically and PID table

A3.1.2 The PIC table

This table specifies which additional identification fields have to be used in order to uniquely identify an incoming TM packet (PI1 and PI2 from previous section). For each packet type/subtype combination, the relevance and the position of the additional identification fields are specified. This table is the same for each instrument and is provided by Thalès.

A3.1.3 The TPCF table

This table contains the characteristics of SCOS-2000 TM Packets i.e. all attributes which are associated to all TM Packets identified by the same SPID. SCE packet mnemonics are listed below. They provide the user with a more meaningful identification of incoming packets.

SPID	Mnemonic	SPID	Mnemonic
190101530	ACC SUCCESS	190314530	DIAG4
190102530	ACC FAILURE	190501530	EVENT REPORT
190103530	EXEC STARTED	190502530	EXCEPTION RE
190107530	EXEC COMPLET	190504530	ERROR REPORT
190108530	EXEC FAILURE	190606559	MEMORY DU AB
190301530	HSK1	190610530	MEMORY CH AB
190302559	HSK2/HSK3	190900530	TIME VERIFIC
190311530	DIAG1	191400530	ENABLE TELEM
190312530	DIAG2	191700530	LINK CONNECT
190313530	DIAG3		

Figure A3-6: Content of the TPSD table



A3.2 Parameters – PCF, PLF and VPD tables

These tables define the monitoring parameters and their location into the SCOS-2000 TM packets, defined in the PID table.

Characteristics of monitoring parameters are defined in the PCF table.

The location of parameters within telemetry packets is specified in the PLF table for packets with a fixed content and in the VPD table for packets with a variable content.

A3.2.1 The PCF table

The PCF is the central table in the definition of monitoring data. It specifies the characteristics of monitoring parameters and has the following main relationships with other tables:

- A many-to-1 relationship with numeric calibration curves (CAF). Each parameter may only reference one curve, but each curve is shareable amongst other parameters. Each curve contains 1 or more points (CAP).
- A many-to-1 relationship with polynomial calibration curves (MCF). Each parameter may only reference one curve, but each curve is shareable amongst other parameters.
- A many-to-1 relationship with textual calibrations (TXF). Each parameter may only reference one textual calibration, but each set is shareable amongst other parameters. Each alias set contains 1 or more text points (TXP).
- A 1-to-1 relationship with monitoring checks definition (OCF). Each parameter may only reference one set of monitoring checks. However, each set may contain up to 16 different monitoring checks with their own type and applicability criteria.
- A many-to-many relationship with telemetry packets (PID). Each parameter may be contained in zero or many packets. The same packet contains many parameters.
- A many-to-many relationship with monitoring displays (DPF, GPF and SPF). Each parameter may be contained in zero or many displays. The same displays contain many parameters and possibly many times the same parameter. The content of monitoring displays is defined in the DPC, GPC and SPC tables.

Several fields and SCE values will be now described.

Notice: the PCF_PID (the On-board ID of the telemetry parameter.) field is not used by SCE.

A3.2.1.1 PCF_NAME Field

The PCF_NAME is an alphanumeric string uniquely identifying the monitoring parameter. Names of monitoring parameters extracted from telemetry packets, not synthetic parameters, are:

- SMxxx530 for parameters in the OBSW system
- SMxxx540 for parameters in the SCE system
where xxx is in the range (0-9) and (A-Z but not O,Q,I)

A3.2.1.2 PCF_UNIT Field

It is the engineering unit mnemonic of the parameter values. This string is shown in monitoring displays besides the calibrated values for all parameters which are associated to a calibration or besides the raw values for all parameters which are not associated to any calibration



In the SCE system, the following units are used:

Quantity	MIB symbol*	SI unit
Electric current	A	Ampere
	mA	Milli-ampere
Pressure	bar	Bar
Temperature	K	Kelvin
	degC	Degree Celsius
Electrical resistance	Ohm	Ohm
Time	s	Second
	ns	Nano-second
Electrical potential	V	Volt
Power	W	Watt

Figure A3-7: Units in the SCE system

* defined by the Thalès Naming Convention Specification

A3.2.1.3 PCF_PTC and PCF_PFC Fields

PCF_PTC, the Parameter Type Code, controls the encoding format of the parameter and PCF_PFC, the Parameter Format Code, controls the length of the parameter, along with the Parameter Type Code

In the SCE system, used combinations are:

PTC	PFC	S2K Parameter Type	Length	PUS type
1	0	Unsigned Integer	1 bit	Boolean parameter
2]0;33[Unsigned Integer	PFC	Enumerated parameter
3	0	Unsigned Integer	4 bits	Unsigned integer parameter
3	4	Unsigned Integer	8 bits	Unsigned integer parameter
3	7	Unsigned Integer	11 bits	Unsigned integer parameter
3	12	Unsigned Integer	16 bits	Unsigned integer parameter
3	14	Unsigned Integer	32 bits	Unsigned integer parameter
4	14	Signed Integer	32 bits	Signed integer parameter
5	1	Simple precision real	32 bits	Simple precision real parameter
9	17	Absolute Time CUC format	48 bits	Absolute Time CUC format

Figure A3-8: PCF_PTC and PCF_PFC used in the SCE system

A3.2.1.4 PCF_WIDTH Field

This field is only used when extracting parameter samples using the VPD definition. If specified, it is used by the SCOS -2000 VPD application to identify the bit position where the next telemetry parameter starts.

It is never used (always 0) in the SCE system.

A3.2.1.5 PCF_VALID and PCF_VALPAR Fields

PCF_VALID is the name of the parameter to be used to determine the state validity of the parameter specified in the record. Only parameters of type integer (signed or unsigned) can be used as validity parameters.

The field PCF_VALPAR provides the validity value (in raw format) to be checked against (PCF_VALID = CF_VALPAR).



In the SCE system, 4 synthetic parameters are used as PCF_VALID:

Synthetic Parameter name	Description
SD101530	The parameter is valid only if the alimentation is ON, used by almost all TM parameters of OBSW system
SD101540	The parameter is valid only if the alimentation is ON, used by almost all TM parameters of SCE system
SD102540	The parameter is valid only if the alimentation is ON and the current mode is "run mode", for beds status MSB and LSB (from housekeeping packets)
SD103540	The parameter is valid only if the alimentation is ON and the current mode is "run or ready mode", for fixed heaters activity, sensor values T1 to T30 and P1 to P8 (from housekeeping packets)

Figure A3-9: Validity on monitoring parameters

Further, in case no instance of a periodic packet is received for a configurable interval, all parameters contained in it are automatically flagged as invalid ('expired'). This feature removes the need to include as part of the validity criteria all the conditions in the on-board status required to ensure that a packet is actually generated and transmitted.

Be aware that this feature is not correctly implemented in all SCOS 2000 versions.

A3.2.1.6 PCF_CATEG Field

PCF_CATEG is the Calibration category of the parameter. In SCE system, only values 'N' and 'S' are used:

- 'N' - for Numerical. This option shall be used for parameters associated to a numerical or polynomial calibration curve. Also numerical parameters which are not associated to any calibration curve should use this option.
- 'S' - for Status. This option should only be used for parameters associated to a textual calibration curve.

A3.2.1.7 PCF_NATUR Field

PCF_NATUR indicates the Nature of the parameter. In SCE system, only values 'R' and 'D' are used:

- 'R' - Raw telemetry parameter, i.e. a monitoring parameter which value is extracted from TM packets
- 'D' - Dynamic OL parameter, i.e. a synthetic parameter specified in Operations Language and not compiled. One ASCII file containing the OL expression associated to this parameter must exist (for more information see the synthetic parameters section)

A3.2.1.8 PCF_CURTX Field

PCF_CURTX indicates the parameter calibration identification number. Depending on parameter category, this field stores the numerical calibration curve identification number or the textual calibration identification number.



For SCOS 2000 version 2.3eP5, this is the only imported data to associate a calibration to a parameter.

For SCOS 2000 version HPCCS (and also EGSE 3.1), another possibility exists: the table CUR, to store conditional calibration curves.

In case of PCF_CURTX and a CUR entry both defined for a parameter, the behavior should depend only on the CUR table but it is not the case. To avoid such cases, when conditional calibration curves are defined no default calibration curve (PCF_CURTX field) is defined.

A3.2.1.9PCF_INTER Field

This flag controls the extrapolation behavior for parameters calibrated using a numerical calibration curve. In the SCE system, if set, its value is always 'F', i.e. if a raw value outside the calibration curve is received, an invalid engineering value is returned.

In case of textual calibration (i.e. PCF_CATEG = 'S'), if a raw value not associated to any text string is received, an invalid engineering value set to all stars '****' is returned.



A3.2.2 The PLF table

A3.2.2.1 General description

This table details the layout of telemetry packets which have a fixed format. Telemetry parameters can appear in several packets at the same time. ‘Overlapping’ entries (i.e. two parameters extracted from the same packet portion) as well as ‘gaps’ (i.e. packets portion from where no parameter value is extracted) are allowed, but not used in the SCE system.

The standard monitoring displays such as ANDs, GRDs and SCDs will make use of the information contained in the PLF table to extract parameter values out of the received packets.

In the SCE system, as there is no supercommutated parameter (every parameter is repeated only once in each TM packet), only the 4 first fields are used:

- PLF_NAME, the name of the parameter
- PLF_SPID, the TM packet identifier
- PLF_OFFBY, the location of first occurrence of parameter value in byte, relative to the end of the SCOS 2000 TM header
- PLF_OFFBI, the bit number, within an octet, of the first bit of the first occurrence of the parameter value. Bit 0 corresponds to the most left bit within the byte.

Let’s detail the content of this table with an example, from housekeeping TM packet.

In the “*Planck Sorption Cooler Electronics OBSW TC and TM Structures*” (ref [AD07]), the content of the boot housekeeping telemetry packet is described as below:

Bit size	Designation	Value	SCOS 2K Specific		
			Range	Byte Offset	Type
16 bits	SID	1		0	
16 bits	Operating mode status		0d→2047d	2	OBSW (530)
16 bits	Faults status OBSW		0d→65535d	4	OBSW (530)

Figure A3-10: Boot software housekeeping packet structure

PID_SPID of the boot housekeeping packet is 190301530.

The SID parameter is not defined in the MIB because it is not relevant as its value is always 1 in the boot mode.

PCF_NAME are SM700530 for *operating mode status* and SM701530 for *faults status OBSW*. So the corresponding values are in PLF:

PLF_NAME	PLF_SPID	PLF_OFFBY	PLF_OFFBI
SM700530	190301530	18	0
SM701530	190301530	20	0

Figure A3-11: PLF example on the boot housekeeping packets

PLF_OFFBY of the SID parameter is 16 as the SID is the first data in the field *application data*, after the *packet header* (48 bits) and the *data field header* (80 bits) – $(48 + 80) / 8 = 16$.

This defines the three 16 bits parameters of the housekeeping telemetry packet. The two last ones have an internal structure. Let’s see the second one: the operating mode state 16 bits parameters is itself composed of several parameters of variable length. Here is it internal structure (ref [AD07]):



15	14	13	12	11	10	9	8	7	6	5	4	3	2	1	0
					Applicative software transfer status Significant for boot software only 0: transferred 1: not transferred	Current process 0: none Bit 6 set: transfer ASW Bit 7 set: test hardware Bit 8 set: memory access (load/dump/check)				4 beds 0: Off 1: On	5 beds 0: Off 1: On	Current state 0: none 1: boot 2: init 3: health monitor (ready) 4: health check (ready) 5: regeneration (ready) 6: startup (run) 7: defrost (run) 8: normal (run) 9: shutdown			

Figure A3-12: Operating mode status definition

This leads the creation of 5 parameters in the PCF table with different PTC/PTF (encoding format and length) and associated values in PLF, as follows:

Parameter	PLF_NAME	PLF_SPID	PLF_OFFBY	PLF_OFFBI
Current State	SM702530	190301530	19	4
5 beds	SM703530	190301530	19	3
4 beds	SM704530	190301530	19	2
Current Process	SM705530	190301530	18	6
Transfert Status	SM706530	190301530	18	5

Figure A3-13: PLF example on the Operating mode status parameter

For 16 bits parameters in which only one bit is significant no 1 bit length parameter has been defined, but a monitoring limits triggered on values different from 0 and 1 have been created (see section A3.5). This is the case for example for the 'Diag PM PROM' parameter from diagnostic packets.

In displays, for housekeeping telemetry in the boot mode, most useful parameters are not the 16 bits ones. So in the main boot screens you will find in priority the more precise ones. In all cases there will be also a way to display the 16 bits parameters, in the same display if it was place enough or in a specific one otherwise.

A3.2.2.2 Specific cases

Usually each parameter is defined only once, in a single telemetry packet. This is mainly due to the fact that there are usually not the same parameters in several telemetry packet type (identified by the PID_SPID field).

But there are some exceptions. Let's see the case of the second and third parameters of housekeeping telemetries in the boot and in the ASW modes, which are the same – that is to say they have the same meaning, the same internal structure and the same location within the telemetry packets.

One solution should have been to define only two parameters: one for operating mode status whatever the mode is and one for fault status OBSW whatever the mode is. But with this



implementation, as there is only one parameter for both modes, the user should have seen, for instance, the operating mode status changed in the boot displays while the system is in ASW!

So in this case, we defined two parameters: operating mode status is SM700530 in the boot mode and it is SM730530 in ASW. They are separately showed in displays, as displays have been designed per mode.

This distinction is done also for example for the diagnostic parameter report packets:

- The '*diagnostic PM PROM*' parameter is SM298530 for the boot mode and SM800530 for the ASW mode.
- The 128 '*Diagnostic DM EEPROM*' parameters are SM163530 to SM290530 for the boot mode and SM801530 to SM928530 for the ASW mode.

One complication by doing like this is that for some very specific parameters, we also need to have the value whatever the mode is. Let's continue with the example of the current mode parameter.

As explain before, the SCE MIB defines two different parameters: SM702530 in the boot mode and SM732530 for the ASW mode. For pre transmission verification purpose, we set that the command '*Transfert Applicative Software*' can be set only is the current mode is boot. To do that we need to have a parameter which give the current mode (boot, init, ...). This parameter is SM502530.

So in PLF table, you can see:

Parameter	PLF_NAME	PLF_SPID	PLF_OFFBY	PLF_OFFBI
Current State	SM702530	190301530	19	4
	SM732530	190302530		
	SM502530	190301530		
	SM502530	190302530		

Figure A3-14: PLF example on the Current state parameter



So it is normal in the SCE MIB files to have different parameters in some packets on the same locations. The different cases are described below:

Parameter Description	PCF_NAME	Purpose	PID_SPID (=PLF_SPID)	Packet Description	PLF_OFFBY	PLF_OFFBI
Diag PM Prom	SM298530	Boot TM	190311530	DIAG1	22	0
	SM800530	ASW TM	190312530	DIAG2	18	0
	SM799530	TC completion whatever the mode is	190311530	DIAG1	22	0
			190312530	DIAG2	18	0
Current State	SM702530	Boot TM	190301530	HSK1	19	4
	SM732530	ASW TM	190302530	HSK2		
	SM502530	PTV whatever the mode is	190301530	HSK1		
			190302530	HSK2		
Current process	SM705530	Boot TM	190301530	HSK1	18	6
	SM735530	ASW TM	190302530	HSK2		
	SM505530	TC completion whatever the mode is	190301530	HSK1		
			190302530	HSK2		

Figure A3-15: PLF special parameters definition

Another special case in PLF is the APID. It is defined in each packet, as follow:

PCF_NAME	PCF_DESCR	PLF_SPID	PLF_OFFBY	PLF_OFFBI
SM665530	APID ACC SUCC	190101530	5	0
SM666530	APID ACC FAIL	190102530		
SM667530	APID EXEC STAR	190103530		
SM668530	APID EXEC COMP	190107530		
SM669530	APID EXEC FAIL	190108530		
SM670530	APID HSK1	190301530		
SM671530	APID HSK2_3	190302530		
SM672530	APID DIAG1	190311530		
SM673530	APID DIAG2	190312530		
SM674530	APID DIAG3	190313530		
SM675530	APID EVENT	190501530		
SM676530	APID EXCEPTION	190502530		
SM677530	APID ERROR	190504530		
SM678530	APID MEMORY	190610530		
SM679530	APID TIME	190900530		

Figure A3-16: PLF definition for the APID parameter



A3.2.3 The VPD table

This table contains the definition of variable TM packets. The VPD has no relation to the DPF, GPF, SPF or PLF table. The VPD will be used for packet processing and display together with the PCF and its related tables.

In the SCE MIB, the VPD table is used to define the structure of telemetries of type 14, subtype 4, that is to say telemetries '*Report Enabled Telemetry Packets*'. For this purpose a PID_TPSD, Telemetry Packet Structure Definition, has been defined: 191400530 – see section A3.1.1.2.

The PID_DFHSIZE field, which specifies the start reference for the processing of variable packets with respect to the end of the SCOS -2000 packet header, is set for this PID_TPSD to 7 bytes (field PID_DFHSIZE).

Telemetry structure from the "*Planck Sorption Cooler Electronics OBSW TC and TM Structures*" document, ref [AD07]:

Packet Header (48 bits)							Packet Data Field		
Packet ID				Packet Sequence Control		Packet Length	Data Field Header	Application Data	Packet Error Control
Version Number	Type	Data Field Header Flag	APID	Segmentation Flag	Source Sequence Count				
3 bits	1 bit	1 bit	11 bits	2 bits	14 bits	16 bits	80 bits		16 bits

Figure A3-17: Telemetry packet structure

Data Field Header						
Spare	TM Source Packet PUS Version Number	Spare	Packet Type	Packet Sub type	Spare	Time
1 bit	3 bits	4 bits	8 bits	8 bits	8 bits	48 bits

Figure A3-18: Data field header structure

Packet Header	Data Field Header		Application Data			
Packet Length	Packet Type	Packet Sub type	N	Type	Sub-Type	Packet-Id
16 bits	8 bits	8 bits	16 bits	8 bits	8 bits	16 bits
32..47	56..63	64..71	128..143	144..151	152..159	160..175
13+N*4	14	4	Number of TM packets definition that follow Range: 0 to 65535d	TM packet service type Range: 1 to 17d	TM Packet service subtype Range: 1 to 26d	See note TC(14,1) Range: 0 to 12d

N times

Figure A3-19: Structure of telemetry service 14 subtype 4



This is translated into the VPD table as:

VPD_POS	Parameter	VPD_NAME	VPD_TPSD	VPD_GRP_SIZE	VPD_OFFSET	VPD_WIDTH
1	Type Subtype	SM652530	191400530	0	0	0
2	N repetitions	SM307530		3	56	2
3	TM Type	SM308530		0	0	2
4	TM Subtype	SM309530		0	0	2
5	Packet ID	SM310530		0	0	2

Figure A3-20: Content of the VPD table

where:

- The VPD_GRP_SIZE field is set for parameters which identify a repeat counter. It specifies the number of parameters in the group to be repeated. In our case only the SM307530 parameter is concerned.
- The VPD_OFFSET field is the number of bits between the start position of the parameter and the end bit of the previous one in the packet. As PID_DFHSIZE is correctly set to 7, VPD_OFFSET is 0 for the SM652530 parameter. For the SM307530 parameter it is set to 56 bits which corresponds to the length of the 'spare' and 'time' parameters from the data field header. For the 3 last ones it is set to 0, as there is no gap between them.
- The VPD_WIDTH field is used to control whether the parameter is displayed. In the SCE system, VPD parameters are all displayed except the first one (SM652530), because it is used only for TC completion verifications.

One important other point is that the SM652530 parameter needs also to have an entry in the PLF table, because it is used for TC completion verification and parameters used for this purpose must be defined in PLF. Its definition in PLF is:

Parameter	PLF_NAME	PLF_SPID	PLF_OFFBY	PLF_OFFBI
Type Subtype	SM652530	191400530	7	0

Figure A3-21: PLF and VPD definitions

With this definition of the VPD table, examples of displays of VPD parameters in SCOS 2000 are shown in Figure A3-22 and Figure A3-23.

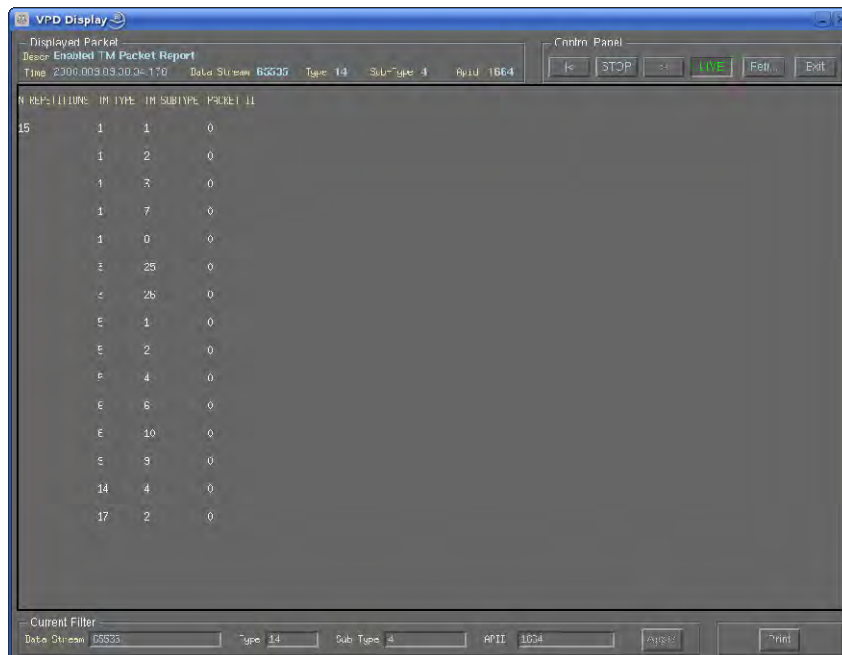

Figure A3-22: An example of VPD display in SCOS 2000 - 1

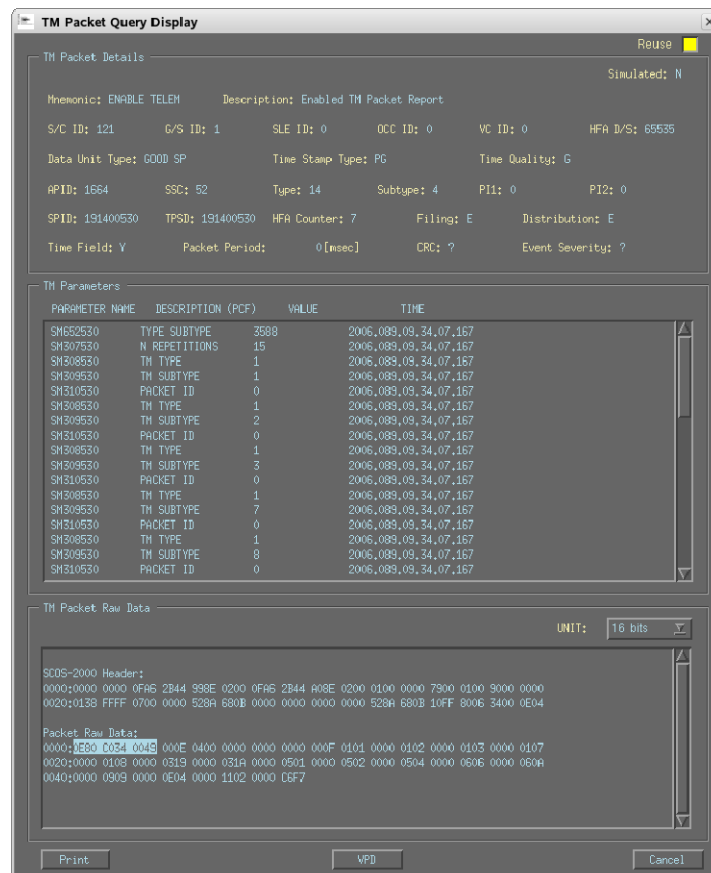

Figure A3-23: An example of VPD display in SCOS 2000 - 2



A3.3 Synthetic parameters

A3.3.1.1 Definition of a synthetic parameter

Synthetic parameters are created to compute states or values than need algorithms calculations. They shall use any telemetries parameters or any other synthetic parameters as source of information (the synthetic parameters were formerly known as derived parameters). They are specified in Operations Language and not compiled. The Operations Language allows the user to quickly implement specific algorithms using the language defined within the Operation Language subsystem, creating the OL scripts. OL scripts are also called Synthetic Parameters.

In the MIB, they are defined as other parameters with an entry in PCF with PCF_NATUR='D' and one ASCII file containing the OL expression associated to this parameter must exist.

A3.3.1.2 Naming of SCE synthetic parameters

Name of synthetic parameters are defined in the PCF_NAME field. It is:

- SDxxx530 for parameters in the OBSW system
 - SDxxx540 for parameters in the SCE system
- where xxx is in the range (0-9) and (A-Z but not O,Q,I)

A3.3.1.3 SCE synthetic parameters description

Parameter name	MIB description	More detailed Description	Default Value
SD000530	PM RAM NB ERROR	Number of errors found in the RAM memory, reported in a TM (3, 26). The calculation is based on values of 128 parameters (from SM002530 to SM129530)	0
SD001530	DM EEPROM ERROR	Number of errors found in the EEPROM memory, reported in a TM (3, 26) in the boot mode. The calculation is based on values of 128 parameters (from SM163530 to SM290530)	0
SD002530	DM EEPROM ERROR	Number of errors found in the EEPROM memory, reported in a TM (3, 26) in the ASW mode. The calculation is based on values of 128 parameters (from SM801530 to SM928530)	0
SD010530	PTV BOOT_INIT	Is true only if the current mode is boot or init (test done on the SM502530 parameter) For PTV purpose	-
SD011530	PTV NOT BOOT	Is true only if the current mode is not boot (test done on the SM502530 parameter) For PTV purpose	-
SD012530	PTV1	Is true only if <ul style="list-style-type: none"> - the current mode is boot (test done on the SM502530 parameter) and the ASW Transfert is done (test on the SM706530 parameter) - or the current mode is init, health monitor, 	-



		health check or regeneration (test done on the SM502530 parameter) For PTV purpose																
SD013530	PTV2	Is true only if the current mode is health monitor; startup, defrost or normal (test done on the SM502530 parameter) For PTV purpose	-															
SD014530	PTV3	Is true only if the current mode is init, health monitor, health check, regeneration or shutdown (test done on the SM502530 parameter) For PTV purpose	-															
SD015540	REGENERATION	Is true only if the current mode is regeneration (test done on the SM502530 parameter) It is used to calculate the synthetic parameter SD016540: 'TEST TYPE'	-															
SD016540	TEST TYPE	This parameter is used to select monitoring limits sets according to the test environment. Its calculation is done with values of SD015540 (regeneration) and SD098540 (cryogenic) – for more detail see section A3.5.5: <table border="1" style="margin-left: auto; margin-right: auto;"> <thead> <tr> <th>SD015540</th> <th>SD098540</th> <th>SD016540</th> </tr> </thead> <tbody> <tr> <td>0</td> <td>0</td> <td>1 (ambient)</td> </tr> <tr> <td>0</td> <td>1</td> <td>2 (cold)</td> </tr> <tr> <td>1</td> <td>0</td> <td>1 (ambient)</td> </tr> <tr> <td>1</td> <td>1</td> <td>0 (regeneration)</td> </tr> </tbody> </table>	SD015540	SD098540	SD016540	0	0	1 (ambient)	0	1	2 (cold)	1	0	1 (ambient)	1	1	0 (regeneration)	-
SD015540	SD098540	SD016540																
0	0	1 (ambient)																
0	1	2 (cold)																
1	0	1 (ambient)																
1	1	0 (regeneration)																
SD017540	READY MODE	Is true only if the current mode is one of the ready modes, i.e. health monitor, health check or regeneration mode (test done on the SM502530 parameter). It is used for the calculation of SD019540.	-															
SD018540	RUN MODE	Is true only if the current mode is one of the run modes, ie startup, defrost or normal mode (test done on the SM502530 parameter). It is used for the calculation of SD102540 validity parameter for housekeeping parameters.	-															
SD019540	READY RUN MODE	Is true only if the current mode is one of the ready or the run modes (test done on the SD017540 and SD018540 parameters). It is used for the calculation of SD103540 validity parameter for housekeeping parameters.	-															
SD020540	STARTUP	Is true only if the current mode is startup (test done on the SM502530 parameter) It is used to calculate the synthetic parameter SD021540: 'TEST TYPE 2'	-															
SD021540	TEST TYPE 2	This parameter is used to select monitoring limits sets according to the test environment and the current mode. Its calculation is done with values of SD016540 (test type) and SD020540 (startup) – for more detail see section A3.5.5:	-															



		SD016540 SD020540 SD021540			
		0	0	0 (regeneration)	
		0	1	0 (regeneration)	
		1	0	1 (ambient)	
		1	1	1 (ambient)	
		2	0	2 (cold)	
		2	1	3 (startup)	
SD028540	T1 OR T2 VALUE	Return T1 value (engineering value of parameter SM018540) if T1 status is 'no error' (SM833540 = 0) T2 value otherwise (engineering value of parameter SM074540)			-
SD029540	T3 OR T4 VALUE	Return T3 value (engineering value of parameter SM019540) if T3 status is 'no error' (SM835540 = 0) T4 value otherwise (engineering value of parameter SM075540)			-
SD030540	T5 OR T6 VALUE	Return T5 value (engineering value of parameter SM020540) if T5 status is 'no error' (SM837540 = 0) T6 value otherwise (engineering value of parameter SM076540)			-
SD031540	T7 OR T30 VALUE	Return T7 value (engineering value of parameter SM021540) if T7 status is 'no error' (SM839540 = 0) T30 value otherwise (engineering value of parameter SM077540)			-
SD051540	INT H21 OOL	Out of limit of intensity in the gas-gap H21*			0
SD052540	INT H22 OOL	Out of limit of intensity in the gas-gap H22*			0
SD053540	INT H23 OOL	Out of limit of intensity in the gas-gap H23*			0
SD054540	INT H24 OOL	Out of limit of intensity in the gas-gap H24*			0
SD055540	INT H25 OOL	Out of limit of intensity in the gas-gap H25*			0
SD056540	INT H26 OOL	Out of limit of intensity in the gas-gap H26*			0
SD061540	INT H21 OOL TXT	Same value as SD051540 but with a textual calibration***			0
SD062540	INT H22 OOL TXT	Same value as SD052540 but with a textual calibration ***			0
SD063540	INT H23 OOL TXT	Same value as SD053540 but with a textual calibration ***			0
SD064540	INT H24 OOL TXT	Same value as SD054540 but with a textual calibration ***			0
SD065540	INT H25 OOL TXT	Same value as SD055540 but with a textual calibration ***			0
SD066540	INT H26 OOL TXT	Same value as SD056540 but with a textual calibration ***			0
SD094540	CALIBRATION TXT	Same value as SD095540 but with a textual calibration ***			-
SD095540	CALIBRATION **	This parameter enables to know which calibration to use, according to the nominal or redundant used cooler (SD099540 parameter) and according to the knowledge of the use of a spare equipment (SD096540 and SD097540 parameters)			-
SD096540	SPARE NOMINAL	This parameter is set to 1 if the nominal electronic system is the spare one			0



SD097540	SPARE REDUNDANT	This parameter is set to 1 if the redundant electronic system is the spare one	0
SD098540	Cryogenic	This parameter must be set by the operator to 'AMBIANT' (0) or to 'COLD' (1), for test purpose. It is used to calculate the synthetic parameter SD016540: 'TEST TYPE'.	1
SD099540	COOLER **	This parameter indicates if the current SCE cooler is the nominal or the redundant one, according to SM671530 parameter (APID of packets from TM (3, 25) in ASW mode). It is used to choice the correct calibration curve. For more detail, see Figure A3-26.	-
SD100530	VALIDITY TM1	Empty, needs to be updated by Thalès to perform: - 0 if alimentation = 'OFF' - 1 if alimentation = 'ON'	1
SD100540	VALIDITY TM1		1
SD101530	VALIDITY TM2	It is valid only if the alimentation is ON, used by almost all TM parameters of OBSW system. It is equals to SD100530.	1
SD101540	VALIDITY TM2	It is valid only if the alimentation is ON, used by almost all TM parameters of SCE system. It is equals to SD100540.	1
SD102530	VALIDITY LUT 1	It is valid only if LUT memory id is 32772 and LUT start address is 256 (for LUT software read back)	-
SD102540	VALIDITY TM3	It is valid only if the alimentation is ON and the current mode is "run mode", for beds status MSB and LSB (from housekeeping packets)	-
SD103530	VALIDITY LUT 8	It is valid only if LUT memory id is 32772 and LUT start address is 451 (for LUT calibrations1 read back)	-
SD103540	VALIDITY TM4	It is valid only if the alimentation is ON and the current mode is "run or ready mode", for fixed heaters activity, sensor values T1 to T30 and P1 to P8 (from housekeeping packets)	-
SD104530	VALIDITY LUT 9	It is valid only if LUT memory id is 32772 and LUT start address is 481 (for LUT calibrations2 read back)	-
SD104540	VALIDITY LUT 2	It is valid only if LUT memory id is 32772 and LUT start address is 304 (for LUT powers and times read back)	-
SD105540	VALIDITY LUT 3	It is valid only if LUT memory id is 32772 and LUT start address is 342 (for LUT health check and regeneration read back)	-
SD106540	VALIDITY LUT 4	It is valid only if LUT memory id is 32772 and LUT start address is 358 (for LUT run mode transition read back)	-
SD107540	VALIDITY LUT 5	It is valid only if LUT memory id is 32772 and LUT start address is 383 (for LUT fault conditions and bad bed detection read back)	-
SD108540	VALIDITY LUT 6	It is valid only if LUT memory id is 32772 and LUT start address is 412 (for LUT PID read back)	-



SD109540	VALIDITY LUT 7	It is valid only if LUT memory id is 32772 and LUT start address is 424 (for LUT heaters resistances read back)	-
----------	----------------	---	---

Figure A3-24: Summary of SCE synthetic parameters

*: OOL for intensity in H21 to H26 are:

- soft OOL: if the intensity is not in [0 ; 0,1] and not in [0,5 ; 0,8]
- hard OOL: if the intensity is not in [0 ; 0,2] and not in [0,4 ; 0,9]



These OOL can not be set directly on the raw parameters with the OCP / OCF table, because OCP and OCF items are not designed for such limits. The used solution consists in setting a part of them on the raw parameters with the OCP / OCF tables and the other with the help of synthetic parameters. Another solution should have been to use only the capability of synthetic parameters, without value in the OCP / OCF tables.

These OOL are defined as:

- a soft OOL on the telemetry parameters (SM059540 to SM064540) if not in [0 ; 8]
- a hard OOL on the telemetry parameters (SM059540 to SM064540) if not in [0 ; 9]
- a soft OOL on an associated synthetic parameter (SD051540 to SD056540) if in [0,1 ; 0,5]
- a hard OOL on an associated synthetic parameter (SD051540 to SD056540) if in [0,2 ; 0,4]

** : the used equipment is in fact a combination of the used cooler and the used SCE electronics. Two coolers exist: FM1 and FM2 and there are 3 SCE electronics cards: FM1, FM2 and PFM. PFM is the spare one and is able to replace either FM1 or FM2 in case of failure. Not all combinations are allowed. Here are the possible ones:

	Cooler FM1 Redundant	Cooler FM2 Nominal
Electronic FM1	FM1	Not possible
Electronic FM2	Not possible	FM2
Electronic PFM	PFM1	PFM2

Figure A3-25: Different combinations of coolers and SCE electronics

To know which cooler is used, the SD099540 parameter is used. It is calculated with the value of the SM671530 parameter (APID of packets from TM (3, 25) in ASW mode), as described in the Figure A3-26. For calibration of pressure sensors, the curves to use are depending only of the cooler not of the SCE electronics, so for them the parameter SD099540 is the only one to use to set the correct calibration curve to use.

APID (SM671530)	SD099540	Cooler
1664	1	Nominal (FM2)
1665	0	Redundant (FM1)
1666	1	Nominal (FM2)
1667	0	Redundant (FM1)

Figure A3-26: Cooler and APID



For temperature sensors T1 to T18 and T26 to T30, the calibration curve to choose is dependant to the SD095540 parameter, which itself depends on the cooler (SD099540) and if a spare element is used (SD096540 and SD097540 parameters), according to the Figure A3-27.

SD099540 (Cooler)	SD096540 (nominal is spare)	SD097540 (redundant is spare)	SD095540
0	0	0	1 (FM1)
0	0	1	3 (PFM1)
0	1	0	1 (FM1)
0	1	1	0 (not possible)
1	0	0	2 (FM2)
1	0	1	2 (FM2)
1	1	0	4 (PFM2)
1	1	1	0 (not possible)

Figure A3-27: Calibration curves according to the cooler and the use of spare element

: when a parameter is associated to a textual calibration, it is not possible to set monitoring limits on it with the OCF / OCP facility, instead if a raw value not associated to any text string is received, an invalid engineering value set to all stars '*' is returned. So when for a more understandable display it is better a set a textual calibration on a limit monitored parameter, it has been decided to create two parameters with the same raw value: one not calibrated for the limit monitoring purpose and one to be associated to the appropriate textual calibration. This happens only with the following synthetic parameters:

- intensity for the H21 to H26 (SD051540 to SD056540)
- the calibration to be used (SD095540 and SD094540)

Very important notice for the SCOS 2000 operator

Before starting SCOS 2000, do not forget to set:

- values for SD098540 (Cryogenic) and SD016540 (TEST TYPE)
- values for SD100530 and SD100540 (validity from alimentation)
- values for SD096540 and SD097540 (use of a spare equipment: the SCE PFM electronics)



A3.4 Calibrations – CAF, CAP, TXF, TXP, MCF and CUR tables

The following sections define the tables required to perform calibration of monitoring parameter values. Calibrations can be applied to any type of monitoring parameters (i.e. raw telemetry parameters as well as synthetic parameters). For synthetic parameters, the source value is the value returned by the associated OL. Only parameters which in their raw representation are of a numerical nature can be associated to a calibration (i.e. no strings, times).

CAF and CAP tables are used for numerical calibrations, TXF and TXP for textual calibrations and MCF for polynomial calibrations. LGF table, for logarithm calibration curves, is not used in the SCE system. The CUR table is used to select calibration curve according to condition.

Although the MIB ICD allows to have the same curve identifiers in CAP and TXP, the Thalès naming convention for S2K curves specifies that curve identifier must be unique independently of type. This point is detailed in Figure A3-35.

Calibration curves are linked to parameters with the PCF_CURTX field or with the CUR table entries (for more detail see section A3.2.1.8). One rule has been respected for the SCE system: when conditional calibration curves are defined no default calibration curve (PCF_CURTX field) is defined.

A3.4.1 The CAF and CAP tables - Numerical calibrations

The CAF table defines the numerical calibration curves corresponding to one or more monitoring parameters. One record is needed per calibration curve.

The CAP table contains the numerical value pairs defining the monitoring calibration curves. One record is needed per raw/engineering value pair.

For element 530, there are 8 numerical calibration curves. They are used for calibration of LUT parameters. Their identifiers are from 301 to 308. They are:

Identifier	Description	Identifier	Description
301	EXTERNAL_TIMER	305	CAL_T3_R0_R1
302	FPGA_TIMER	306	CAL_T3_Z
303	CAL_ADC	307	CAL_T3_A
304	CAL_GAIN_OFST	308	TBED_TRB

Figure A3-28: Numerical calibration curves for element 530

For element 540, there are 132 numerical calibration curves. 111 are used for calibration of physical parameters and 21 others for calibration of LUT parameters. Their identifiers are from 001 to 097 (with some holes) and from 401 to 458. They are:

Identifier	Description	Identifier	Description
001	CERNOX T1 FM2 [5 ; 180]	090	FAULT_CONDT_TIME
002	CERNOX T2 FM2 [11.5 ; 235]	091	FAULT_CONDT_V
003	CERNOX T3 FM2 [9.3 ; 200]	092	FAULT_CONDT_HTR
004	CERNOX T4 FM2 [5.3 ; 148]	093	PID_P
005	CERNOX T5 FM2 [8.9 ; 30]	094	PID_I
006	CERNOX T6 FM2 [15.8 ; 48]	095	PID_RATE
007	CERNOX T7 FM2 [5.3 ; 156]	096	OPEN_LOOP_R1



008	CERNOX T8 FM2 [20.5 ; 500]	097	HTR_OHM
009	CERNOX T9 FM2 [15.5 ; 500]	401	PRT T13 FM1 [239.12 ; 396.033]
010	CERNOX T10 FM2 [22.72 ; 400]	402	PRT T14 FM1 [239.108 ; 395.822]
011	CERNOX T11 FM2 [37 ; 500]	403	PRT T15 FM1 [219.3 ; 375.257]
012	CERNOX T12 FM2 [45.2 ; 450]	404	PRT T16 FM1 [219.478 ; 375.723]
013	PRT T13 FM2 [239.19 ; 396.105]	405	PRT T17 FM1 [239.097 ; 396.015]
014	PRT T14 FM2 [239.15 ; 396.043]	406	PRT T18 FM1 [239.07 ; 395.703]
015	PRT T15 FM2 [219.336 ; 375.297]	407	PRT T26 FM1 [219.362 ; 375.218]
016	PRT T16 FM2 [219.356 ; 375.476]	408	PRT T27 FM1 [219.352 ; 375.396]
017	PRT T17 FM2 [239.24 ; 396.048]	409	PRT T28 FM1 [219.298 ; 375.422]
018	PRT T18 FM2 [239.154 ; 396.188]	410	PRT T29 FM1 [219.396 ; 375.478]
020	KTC T20 TO T25	411	CERNOX T1 PFM2 [5 ; 180]
026	PRT T26 FM2 [219.305 ; 377.078]	412	CERNOX T2 PFM2 [11.5 ; 235]
027	PRT T27 FM2 [219.322 ; 375.432]	413	CERNOX T3 PFM2 [9.5 ; 200]
028	PRT T28 FM2 [219.32 ; 375.506]	414	CERNOX T4 PFM2 [5.3 ; 148]
029	PRT T29 FM2 [219.3 ; 375.382]	415	CERNOX T5 PFM2 [8.9 ; 30]
030	CERNOX T30 FM2 [15.4 ; 250]	416	CERNOX T6 PFM2 [15.8 ; 48]
031	P1 FM2 [0.219960112 ; 68.95749501]	417	CERNOX T7 PFM2 [5.3 ; 156]
032	P2 FM2 [0.317331865 ; 69.30252002]	418	CERNOX T8 PFM2 [20.5 ; 500]
033	P3 FM2 [0.041316683 ; 68.90245554]	419	CERNOX T9 PFM2 [15.5 ; 500]
034	P4 FM2 [0.275995996 ; 69.27499499]	420	CERNOX T10 PFM2 [22.72 ; 400]
035	P5 FM2 [0.358794795 ; 69.35779379]	421	CERNOX T11 PFM2 [37 ; 500]
036	P6 FM2 [0.166096386 ; 69.37292369]	422	CERNOX T12 PFM2 [45.2 ; 450]
037	P7 FM2 [0.482413517 ; 69.39863027]	423	PRT T13 PFM2 [239.172 ; 396.074]
038	P8 FM2 [-0.006928571 ; 3.457356807]	424	PRT T14 PFM2 [239.192 ; 395.923]
051	CERNOX T1 FM1 [10 ; 210.057]	425	PRT T15 PFM2 [219.24 ; 375.202]
052	CERNOX T2 FM1 [5 ; 142]	426	PRT T16 PFM2 [219.251 ; 375.348]
053	CERNOX T3 FM1 [5.8 ; 180.053]	427	PRT T17 PFM2 [239.345 ; 396.265]
054	CERNOX T4 FM1 [5.2 ; 150.077]	428	PRT T18 PFM2 [239.142 ; 395.788]
055	CERNOX T5 FM1 [6.9 ; 27]	429	PRT T26 PFM2 [219.246 ; 375.07]
056	CERNOX T6 FM1 [12.3 ; 39]	430	PRT T27 PFM2 [219.305 ; 375.427]
057	CERNOX T7 FM1 [10.1 ; 187]	431	PRT T28 PFM2 [219.212 ; 375.302]
058	CERNOX T8 FM1 [14.2 ; 500]	432	PRT T29 PFM2 [219.278 ; 375.36]
059	CERNOX T9 FM1 [11.2 ; 400]	433	CERNOX T30 PFM2 [15.4 ; 250]
060	CERNOX T10 FM1 [10.5 ; 400]	434	CERNOX T1 PFM1 [10 ; 210.057]
061	CERNOX T11 FM1 [18.118 ; 400]	435	CERNOX T2 PFM1 [5 ; 142]
062	CERNOX T12 FM1 [51 ; 500]	436	CERNOX T3 PFM1 [5.8 ; 180.053]
063	CERNOX T30 FM1 [10.2 ; 190]	437	CERNOX T4 PFM1 [5.2 ; 150.077]
064	P1 FM1 [0.288870485 ; 69.06755737]	438	CERNOX T5 PFM1 [6.9 ; 27]
065	P2 FM1 [0.206377246 ; 68.99879242]	439	CERNOX T6 PFM1 [12.3 ; 39]
066	P3 FM1 [0.303413365 ; 69.2609964]	440	CERNOX T7 PFM1 [10.1 ; 187]
067	P4 FM1 [-0.027533453 ; 68.80609946]	441	CERNOX T8 PFM1 [14.2 ; 500]
068	P5 FM1 [0.055155031 ; 68.99894379]	442	CERNOX T9 PFM1 [11.2 ; 400]
069	P6 FM1 [0.220973753 ; 69.27527149]	443	CERNOX T10 PFM1 [10.5 ; 400]
070	P7 FM1 [0.234221467 ; 69.12288827]	444	CERNOX T11 PFM1 [18.118 ; 400]
071	P8 FM1 [0.009678595 ; 3.466319612]	445	CERNOX T12 PFM1 [51 ; 500]
072	TEMPERATURE ELECTRONIC	446	PRT T13 PFM1 [239.172 ; 396.074]
073	INTENSITY H21-H26	447	PRT T14 PFM1 [239.192 ; 395.923]
075	HEATER_POWER	448	PRT T15 PFM1 [219.24 ; 375.202]
076	POWER_LPSB	449	PRT T16 PFM1 [219.251 ; 375.348]
077	CYCLE_TIME	450	PRT T17 PFM1 [239.345 ; 396.265]
078	BED_CYCLE	451	PRT T18 PFM1 [239.142 ; 395.788]
079	TIME_LIMIT	452	PRT T26 PFM1 [219.246 ; 375.07]
080	MAX_POWER	453	PRT T27 PFM1 [219.305 ; 375.427]



081	MIN_POWER	454	PRT T28 PFM1 [219.212 ; 375.302]
082	DELTAT_COLD	455	PRT T29 PFM1 [219.278 ; 375.36]
083	TIME_LIMIT_COLD	456	CERNOX T30 PFM1 [10.2 ; 190]
085	REGEN_TIME	457	DELTA P8 FM2
087	ADJUST_MCTFIRST	458	DELTA P8 FM1

Figure A3-29: Numerical calibration curves for element 540

In the Figure A3-29, ranges which depend on the used equipment are detailed. It has been decided that all monitoring limits for all sensors are not related to the used equipment (use of a spare electronic system, nominal or redundant cooler ...). To do so the Figure A3-30 lists all physical sensors and the intersection of all the related numerical calibration curve for all equipments.

Sensor	Range	Sensor	Range
T1	[10 ; 180]	T17	[239.345 ; 396.015]
T2	[11.5 ; 142]	T18	[239.154 ; 395.703]
T3	[9.5 ; 180.053]	T26	[219.362 ; 375.07]
T4	[5.3 ; 148]	T27	[219.305 ; 375.432]
T5	[6.9 ; 27]	T28	[219.32 ; 375.302]
T6	[15.8 ; 39]	T29	[219.396 ; 375.36]
T7	[10.1 ; 156]	T30	[15.4 ; 190]
T8	[20.5 ; 500]	P1	[0.288870485 ; 68.95749501]
T9	[15.5 ; 500]	P2	[0.317331865 ; 68.99879242]
T10	[22.75 ; 400]	P3	[0.303413365 ; 68.90245554]
T11	[37 ; 400]	P4	[0.275995996 ; 68.80609946]
T12	[51 ; 450]	P5	[0.358794795 ; 68.99894379]
T13	[239.19 ; 396.033]	P6	[0.220973753 ; 69.27527149]
T14	[239.172 ; 395.822]	P7	[0.482413517 ; 69.12288827]
T15	[219.336 ; 375.202]	P8	[0.009678595 ; 3.457356807]
T16	[219.478 ; 375.348]		

Figure A3-30: Ranges for physical sensors over all numerical calibration curves

A3.4.2 The TXF and TXP tables- Textual calibration

The TXF table defines the textual calibrations (also known as aliases sets) corresponding to one or more monitoring parameters. One record is needed per textual calibration.

The TXP table defines the text strings corresponding to one or more parameter raw values. One record is needed per values/string pair.

For element 540, they are:

Identifier	Description	Values
201	BED_MODE	NORMAL OFF / NORMAL ON
202	BED_STATUS	OFF / HEATUP / DESORB / COOL / ABSORB1 / ABSORB2 / ABSORB3
203	OOL	NOT OOL / SOFT OOL / HARD OOL
204	ERROR	NO ERROR / ERROR
205	CRYOGENIC	AMBIANT / COLD
206	TEST ENVIRONMENT	REGENERATION / AMBIANT / COLD
207	CALIBRATION	NOT POSSIBLE / FM1 / FM2 / PFM1 / PFM2
208	TEST ENVIRONMENT 2	REGENERATION / AMBIANT / COLD / STARTUP

Figure A3-31: Textual calibration curves for element 540



and for element 530:

Identifier	Description	Values
310	FAILURE CODE	ILLEGAL APID / INVALID LENGTH / BAD CHECKSUM / BAD PKT TYPE / BAD PKT SUBTYPE / BAD APPLIC DATA / BAD MEMORY LOAD / BAD MEMORY DUMP / BAD MEMORY CHECK / ASW NOT LOADED / PACKET HEADER / TRANSFERT LAYER / WAIT COMPLETION
311	APID	NOMINAL / REDUNDANT
312	CURRENT_MODE	NONE / BOOT / INIT / HEALTH MONITOR / HEALTH CHECK / REGENERATION / STARTUP / DEFROST / NORMAL / SHUTDOWN
314	EVENT_TYPE	BOOT / BED CHANGED / SWITCH OFF / INIT / HEALTH MONITOR / HEALTH CHECK / REGENERATION / STARTUP / DEFROST / NORMAL / SHUTDOWN
315	CURRENT_PROCESS	NONE / TRANSFERT ASW / TEST HARDWARE / MEMORY ACCESS
316	TRANSFERT_STATUS	TRANSFERRED / NOT TRANSFERRE
317	ERROR	NO ERROR / ERROR
318	RESTORATION_STATUS	RESTORE OK / RESTORE ERROR
319	HEALTH_CHECK_TEST_NB	See below
320	REGENERATION_PROCESS	See below
321	ESSENTIAL	NON ESSENTIAL / ESSENTIAL
322	MEMORY ID	DM RAM 1 / DM RAM 2 / DM EXTERNAL / DM FPGA 1 / DM FPGA 2 / DM EEPROM 1 / DM EEPROM 2 / DM EEPROM 3 / DM EEPROM 4 / DM EEPROM 5 / DM EEPROM 6 / DM EEPROM 7 / DM EEPROM 8 / PROM OR PMRAM / PM RAM (ASW) / PROM OR PMRAM / PM RAM (BOOT) / DM 1553

Figure A3-32: Textual calibration curves for element 530

For curve 319 (HEALTH_CHECK_TEST_NB) and 320 (REGENERATION_PROCESS), possible values are:

Possible values for curve 319	
NONE	BED1 MIN POWER
SUSTAIN HEATER	BED1 GAS GAP
BED3 MIN POWER	JT H34 HEATER
BED3 GAS GAP	JT H35 HEATER
BED4 MAX POWER	JT H33 HEATER
BED4 MIN POWER	JT H36 HEATER
BED4 GAS GAP	JT H31 HEATER
BED5 MAX POWER	JT H32 HEATER
BED5 MIN POWER	BED1 MAX POWER
BED5 GAS GAP	BED1 MIN POWER
BED6 MAX POWER	BED1 GAS GAP
BED6 MIN POWER	BED2 MAX POWER
STARTUP HEATER	BED2 MIN POWER
BED6 GAS GAP	BED2 GAS GAP

Possible values for curve 320	
NONE	BED5 PHPST
HPST PRESSURE	BED5 TEMPERATU
BED2 REGENERAT	BED5 REGENERAT
BED2 COOL	BED5 COOL
BED3 GAS GAP	BED6 GAS GAP
BED3 PHPST	BED6 PHPST
BED3 TEMPERATU	BED6 TEMPERATU
BED3 REGENERAT	BED1 PHPST
BED3 COOL	BED6 REGENERAT
BED4 GAS GAP	BED6 COOL
BED4 PHPST	BED1 TEMPERATU
BED4 TEMPERATU	BED1 REGENERAT
BED1 GAS GAP	BED1 COOL
BED4 REGENERAT	BED2 GAS GAP



BED1 MAX POWER	BED3 MAX POWER	BED4 COOL	BED2 PHPST
		BED5 GAS GAP	BED2 TEMPERATU

Figure A3-33: Possible values for textual calibration curves 319 and 320

A3.4.3 The MCF table - Polynomial calibrations

The MCF table contains the coefficients associated to the polynomial calibration curves. One record is needed per polynomial calibration curve. SCOS-2000 will calculate the engineering value 'Y' corresponding to the raw value 'X' of a parameter using the following formula:

$$Y = A0 + A1 * X + A2 * X^2 + A3 * X^3 + A4 * X^4$$

In the SCE system, MCF entries are used for calibration of physical values of element 540:

Identifier	Description	A0	A1
101	Intensity H7	0	0.01486
102	IntensityH31 - H32	0	0.001239
103	Tension 28V	0	0.0004578
104	Tension 12V	0	0.000305
105	Tension 5V	0	0.0001526
106	Tension +15V	0	0.000305
107	Tension -15V	0	-0.000305
108	Tension 31V	0	0.000763
112	Tension on H11-H16	28.1	-0.006862
113	Tension on H31-H32	40.2	-0.00981685
114	Tension on H7	15	-0.003663

Figure A3-34: Polynomial calibration curves

A3.4.4 The CUR table

It is used to hold the conditional condition items for calibration. In the SCE system it is used to choose numerical calibration curve for physical parameters of element 540, depending on the used equipment. Concerned physical parameters are those related to the following sensors: the cernox T1 to T12, the cernox T30, the PRT T13 to T18 and T26 to T29 and pressure P1 to P8. They can be divided into two parts:

- Those depending on the complete equipment (cooler and electronic systems), that is to say to the SD095540 synthetic parameter: the cernox T1 to T12, the cernox T30 and the PRT T13 to T18 and T26 to T29
- Those depending only on the cooler system, that is to say to the SD099540 synthetic parameter: the pressure sensors P1 to P8 and the Delta_P8 (slope only of the P8 sensor) for the LUT purpose.

A3.4.5 Curve identifiers

Here is a summary of used curve identifiers (it includes the 4 calibration curves defined for TC only):



	Element 540	Element 530
Numerical calibration curves	1 -> 38 51 -> 97 401 -> 458	301 -> 308
Textual calibration curves	201 -> 208	310 -> 322 502 -> 504 for TC only 323 for TC only
Polynomial calibration curves	101 -> 114	

Figure A3-35: Calibration curves identifiers

Remarks:

- In the MIB files, calibration curves are described for telemetries and for commands in separate tables:
 - CAP, TXF, TXP, MCF, LGF and Cur or telemetries
 - CCA, CCS, PAF and PAS for commands
 But in the XML file they are described at the same place for telemetries and command:
 - DISCRETE_CURVE_TH
 - TEXTUAL_CURVE_TH
 - POLYNOMIAL_CURVE_TH
 For each entry in these section, the field '*CurveUse*' indicates if the curve is for telemetry purpose '*M*', for command purpose '*T*' or for both '*B*'. So a unique curve identifier in the XML file can lead to two distinct calibration curve in MIB file if the '*B*' curveUse is set.
- Depending on the used equipment, the CUR table allows to choose a calibration curve for telemetry parameters. As there is no equivalent mechanism for commands, distinct commands for the 4 different equipments are defined (this is the case only for the LUT commands).

A3.5 Monitoring limits – OCF and OCP tables

A3.5.1 General description

The OCF table defines for each parameter name, the characteristics of the monitoring checks to be applied to it. At most one record is allowed per parameter.

The OCP table contains the definition of the monitoring checks associated to each monitoring parameter specified in the OCF table. The checks associated to a parameter are executed by SCOS-2000 in the order in which they are specified in this table. Each check is associated to an applicability criteria which enables its execution (OCP_RLCHK = OCP_VALPAR).

Main OCP/OCF table fields are:

- OCF_NAME and OCP_NAME matches with PCF_NAME of the parameter to be checked.
- OCF_NBCHCK is the number of consecutive valid parameter samples violating the check required to declare the parameter as OOL.
- OCP_TYPE is a flag identifying the type of monitoring check amongst:
 - o 'S' – Soft OOL
 - o 'H' – Hard OOL



- 'C' – Status Consistency
- 'E' - Event generation only (no OOL).
- OCP_LVALU is used as the low limit value (for numerical parameters i.e. if PCF_CATEG = 'N') or as the expected status value (for status parameters i.e. if PCF_CATEG = 'S'). This field is irrelevant for Status Consistency checks (OCP_TYPE='C').
- OCP_HVALU is used as the high limit value. This field is only relevant for checks associated to numerical parameters (PCF_CATEG = 'N'). It is irrelevant for checks associated to status parameters (PCF_CATEG='S') and for Status Consistency checks (OCP_TYPE = 'C').
- OCP_RLCHK is the name of the parameter to be used to determine the applicability of this monitoring check. Only parameters of type integer (signed or unsigned) can be used as applicability parameters. The field OCP_VALPAR provides the applicability value to be checked against. Note that SCOS-2000 automatically takes the validity of the applicability expression (OCP_RLCHK = OCP_VALPAR) into account to evaluate the check applicability. This field is not used for Status Consistency checks (OCP_TYPE='C').

On the top of the traditional monitoring checks, SCOS-2000 support also checks of type Event (OCP_TYPE = 'E') are not meant to be used for monitoring purposes. These checks are to be used as a mechanism to trigger the generation of SCOS-2000 event packets based on the detection of a specific condition in the telemetry data. This feature is not used in the SCE system, only OCP_TYPE 'S' or 'H', i.e. soft or hard out of limits, are triggered.

The following rules for the population/processing of OCP records apply:

- Checks associated to a parameter are checked for applicability in the order of import (the table is supposed to be sorted in an appropriate order based on OCP_NAME and OCP_POS).
- The checks applicability criteria (parameter OCP_RLCHK valid and equal to OCP_VALPAR) are used to determine the applicability of all checks except Status Consistency checks (OCP_TYPE='C') for which the applicability criteria is forced to TRUE.
- The identification of applicable checks for a parameter stops as soon as an applicable check or a Soft/Hard pair of applicable checks is encountered.
- Checks of type Status Consistency (OCP_TYPE='C') or Events (OCP_TYPE='E') must always precede other checks for the same parameter (if any).
- Soft/Hard pairs of monitoring checks must be associated to the same applicability criteria and must follow each other in the order Soft/Hard. It is allowed to have the same low or high limit value for Soft and Hard limits associated to the same applicability criteria.
- A Soft OOL check (OCF_TYPE='S') can be specified in isolation i.e. it does not necessarily require the existence of a Hard OOL check associated to the same applicability criteria.
- A Soft or Hard check is violated if the telemetry is outside the allowed range of values. In case the telemetry value matches exactly one of the limit values, this is not considered as an OOL condition.
- Parameters violating several checks (e.g. a Soft and a Hard check) are displayed according to the violated check with the higher criticality.



A3.5.2 Monitoring limits for uncalibrated parameters

Some parameters defined in the “*Sorption Cooler Electronics OBSW TC and TM Structures*” document (ref [AD07]) don’t rely on physical values, so they are not linked to numerical calibration (PCF_CATEG = N and PCF_CURTX is null). Some of them have a 16 bits length but all bits are not used. To verify that values of these parameters are inside the expected range, OCP/OCF entries have been entered. They are described in the Figure A3-36.

PCF_NAME	PCF_DESCR	OCP_LVALUE	OCP_HVALUE
SM700530 SM730530	Mode status	0	2047
SM000540	Fault status SC	0	63
SM001540	Beds status MSB	0	32767
SM002540	Beds status LSB	0	511
SM003540	Fixed heaters 1	0	32767
SM014540	Device status 2	0	4095
SM016540	Device status 4	0	16383
SM017540	Device status 5	0	255
SM100540	fixed heaters 2	0	3
SM162530	Diag DM RAM	0	3
SM292530	External timers	0	1023
SM295530	HC status MSB	0	8191
SM296530	Diag 1553	0	63
SM297530	Diag FPGA	0	511
SM799530	Diag PM Prom	0	1
SM308530	TM Type	1	17
SM309530	TM SubType	1	26
SM310530	Packet ID	0	12
SM312530	SID TM5	0	0
SM313530	Parameter A1	0	0
SM315530	Parameter A2	0	0
SM320530	RegenerationMSB	0	32767
SM651530	Type SubType 9	2313	2313
SM652530	Type SubType 14	3588	3588
SM653530	Type SubType 17	4354	4354

Figure A3-36: Monitoring limits for uncalibrated parameters

All these monitoring limits are hard limits (OCP_TYPE = H) and only one check is done (OCF_NBCHECK= 1).

A3.5.3 Monitoring limits for textual calibrated parameters

This section deals with parameters associated to a textual calibration curve (PCF_CATEG = S). In case of textual calibration, if a raw value not associated to any text string is received, an invalid engineering value set to all stars “****” is returned. So there is no need to define out of limit for values out of the calibration curves. An exception is for some synthetic parameters which needs both a textual calibration and a hard out of limit. This specific case is detailed in the section A3.3.1.3.



For all parameters associated to the textual calibration curve 317 of element 530 or 204 of element 540, that is to say to 'ERROR' or 'NO ERROR', one hard monitoring limit (OCF_TYPE = H and OCP_NBCHECK = 1) has been defined. The out of limit is triggered when the value is not 0, that is to say when there is an error (OCP_LVALUE = OCP_HVALUE = 0).

Concerned parameters are

- From SM799540 to SM 804540: parameters extracted from the '*Faults Status SCE*', from housekeeping packets in ASW mode
- From SM805540 to SM869540: parameters extracted from the '*Device Status SCE*', from housekeeping packets in ASW mode
- SM291530, the '*Transfert ASW*' from boot diagnostic packets
- From SM550530 to SM555530: parameters extracted from the '*Diagnostic 1553*', from boot diagnostic packets
- From SM707530 to SM722530: parameters extracted from the '*Faults Status OBSW*', from housekeeping packets in boot mode
- From SM737530 to SM752530: parameters extracted from the '*Faults Status OBSW*', from housekeeping packets in ASW mode
- From SM550530 to SM555530: parameters extracted from the '*Diagnostic 1553*', from boot diagnostic packets
- From SM556530 to SM575530: parameters extracted from the '*Diagnostic FPGA*', from boot diagnostic packets
- From SM576530 to SM584530: parameters extracted from the '*Diagnostic External Timers*', from ASW diagnostic packets
- From SM585530 to SM614530: parameters extracted from the '*Health check test status*', from health check diagnostic packets
- From SM615530 to SM645530: parameters extracted from the '*Regeneration status word*', from regeneration diagnostic packets

A3.5.4 Monitoring limits for synthetic parameters

Some of the synthetic parameters have also monitoring limits associated. Here they are:

- SD000530, SD001530 and SD002530, which define number of error found during diagnostic on memory areas. The defined OOL is a hard one, when the value is not 0 (i.e. OCP_LVALUE = OCP_HVALUE = 0).
- SD0028540 to SD0031540, which correspond to physical values associated to temperature sensors (T1 to T7 and T30). Limits are described in the section A3.5.5.
- SD051540 to SD056540, which are the OOL synthetic parameter for the intensity in the gas-gap H21 to H26. A soft out of limit is defined when the value is not 0 (i.e. OCP_LVALUE = OCP_HVALUE = 0) and a hard one when the value is 2 (i.e. OCP_LVALUE = OCP_HVALUE = 1).
- SD095540 which is used to choose the calibration to be used for conditional numerical calibration curves depending on the equipment. A hard out of limit is defined when the value is not in [1 ; 4].



A3.5.5 Monitoring limits for numerical calibrated parameters

In this section will be discussed numerical calibrated parameters which are not defined for the Lookup Table purpose, as a special section has been created for them (Appendix 1).

The Figure A3-39 presents the monitoring limits for numerical calibrated parameters that is to say physical parameters, associated to sensors. For most of these parameters several sets of limits are defined. They are dependant of the value of the synthetic parameter SD016540. Its available values are: 0 for the 'regeneration' set of monitoring limits, 1 for the 'ambient' set of monitoring limits and 2 for the 'cold' set of monitoring limits

The synthetic parameter SD016540 is calculated with the value of two other synthetic parameters:

- SD098549: this parameter needs to be set manually. SD098540 = 1 for cold environment and SD098540 = 0 for ambient environment
- SD015540: this parameter is 1 when the current mode is regeneration and 0 otherwise

according to the following rules:

Regeneration	Cryogenic	Monitoring limits to use
Yes	Ambient	Use Ambient monitoring limits
Yes	Cold	Use Regeneration monitoring limits
No	Ambient	Use Ambient monitoring limits
No	Cold	Use Cold monitoring limits

Figure A3-37: Test environment parameter definition SD016540

An exception is for sensors T1 to T7 and T30, which not need to be monitor when the system is in the startup mode. To do so, the SD021540 synthetic parameter is used. Its calculation is done with the value of two other synthetic parameters:

- SD016540: the test environment synthetic parameter
- SD020540: this parameter is 1 when the current mode is startup and 0 otherwise

according to the following rules:

Test type	Startup	Test type 2
Regeneration	No	Use Regeneration monitoring limits
Regeneration	Yes	Use Regeneration monitoring limits
Ambiant	No	Use Ambient monitoring limits
Ambiant	Yes	Use Ambient monitoring limits
Cold	No	Use Cold monitoring limits
Cold	Yes	Use Startup monitoring limits

Figure A3-38: Test environment parameter definition SD021540

In Figure A3-39 the H/S column indicates if the limit is a Hard limit ('H') or a Soft limit ('S').



Parameter	Short description	Long description	Unit	H/S	Minimum			Maximum		
					Regen.	Ambiant	Cold	Regen.	Ambiant	Cold
SM004540	H11 value	Bed 1 Variable Heater Voltage	V		N/A					
SM005540	H12 value	Bed 2 Variable Heater Voltage	V							
SM006540	H13 value	Bed 3 Variable Heater Voltage	V							
SM007540	H14 value	Bed 4 Variable Heater Voltage	V							
SM008540	H15 value	Bed 5 Variable Heater Voltage	V							
SM009540	H16 value	Bed 6 Variable Heater Voltage	V							
SM010540	H7 value	LPSB Heater Voltage	V							
SM011540	H31 value	Nominal LR3 Heater Voltage	V							
SM012540	H32 value	Redundant LR3 Heater Voltage	V							
SD028540	T1 OR T2 VALUE	LR1 Temperature	K	S						
SD029540	T3 OR T4 VALUE	LR2 Temperature	K	S						
SD030540	T5 OR T6 VALUE	LR3 Temperature	K	S						
SD031540	T7 OR T30 VALUE	JT Temperature	K	S						
SM022540	T8 value	HX4 Out Temperature (PC3C)	K	S	40			325		
SM023540	T9 value	PC3 Out Temperature	K	S						
SM024540	T10 value	PC3 In Temperature	K	S						
SM025540	T11 value	PC2 Temperature	K	S						
SM026540	T12 value	PC1 Temperature	K	S	120					
SM027540	T13 value	HPSB right Temperature	K		N/A					
SM028540	T14 value	HPSB Left Temperature	K							
SM029540	T15 value	Bed 1 External Temperature	K	S	255	N/A	255	285	N/A	285
SM029540	T15 value	Bed 1 External Temperature	K	H	250		250	300		300
SM030540	T16 value	Bed 2 External Temperature	K	S	255		255	285		285
SM030540	T16 value	Bed 2 External Temperature	K	H	250		250	300		300
SM031540	T17 value	LPSB Left Temperature	K	S	240***			350	306	350



Planck LFI
Sorption Cooler System
User Manual

Document No.: PL-LFI-PST-MA-002
 Issue/Rev. No.: 3.0
 Date: 20 March 2009

SM031540	T17 value	LPSB Left Temperature	K	H			370	307	370
SM032540	T18 value	LPSB Middle Temperature	K	S			350	306	350
SM032540	T18 value	LPSB Middle Temperature	K	H			370	307	370
SM034540	T20 value	Bed 1 Delta T (Internal/External)	degC	S		-3	410	18	230
SM034540	T20 value	Bed 1 Delta T (Internal/External)	degC	H		-6	430	20	255
SM035540	T21 value	Bed 2 Delta T (Internal/External)	degC	S		-3	410	18	230
SM035540	T21 value	Bed 2 Delta T (Internal/External)	degC	H		-6	430	20	255
SM036540	T22 value	Bed 3 Delta T (Internal/External)	degC	S		-3	410	18	230
SM036540	T22 value	Bed 3 Delta T (Internal/External)	degC	H		-6	430	20	255
SM037540	T23 value	Bed 4 Delta T (Internal/External)	degC	S		-3	410	18	230
SM037540	T23 value	Bed 4 Delta T (Internal/External)	degC	H		-6	430	20	255
SM038540	T24 value	Bed 5 Delta T (Internal/External)	degC	S		-3	410	18	230
SM038540	T24 value	Bed 5 Delta T (Internal/External)	degC	H		-6	430	20	255
SM039540	T25 value	Bed 6 Delta T (Internal/External)	degC	S		-3	410	18	230
SM039540	T25 value	Bed 6 Delta T (Internal/External)	degC	H		-6	430	20	255
SM040540	T26 value	Bed 3 External Temperature	K	S	255	N/A	255	320	320
SM040540	T26 value	Bed 3 External Temperature	K	H	250		250	330	330
SM041540	T27 value	Bed 4 External Temperature	K	S	255		255	320	320
SM041540	T27 value	Bed 4 External Temperature	K	H	250		250	330	330
SM042540	T28 value	Bed 5 External Temperature	K	S	255		255	320	320
SM042540	T28 value	Bed 5 External Temperature	K	H	250		250	330	330
SM043540	T29 value	Bed 6 External Temperature	K	S	255		255	320	320
SM043540	T29 value	Bed 6 External Temperature	K	H	250		250	330	330
SM044540	P1 value	Bed 1 Pressure	bar	S		0 ***	53.8	1.93	53.8
SM044540	P1 value	Bed 1 Pressure	bar	H			55.2 *	2.07	55.2 *
SM045540	P2 value	Bed 2 Pressure	bar	S			53.8	1.93	53.8
SM045540	P2 value	Bed 2 Pressure	bar	H			55.2 *	2.07	55.2 *
SM046540	P3 value	Bed 3 Pressure	bar	S			53.8	1.93	53.8
SM046540	P3 value	Bed 3 Pressure	bar	H			55.2 *	2.07	55.2 *



Planck LFI
Sorption Cooler System
User Manual

Document No.: PL-LFI-PST-MA-002

Issue/Rev. No.: 3.0

Date: 20 March 2009

SM047540	P4 value	Bed 4 Pressure	bar	S		53.8	1.93	53.8
SM047540	P4 value	Bed 4 Pressure	bar	H		55.2 *	2.07	55.2 *
SM048540	P5 value	Bed 5 Pressure	bar	S		53.8	1.93	53.8
SM048540	P5 value	Bed 5 Pressure	bar	H		55.2 *	2.07	55.2 *
SM049540	P6 value	Bed 6 Pressure	bar	S		53.8	1.93	53.8
SM049540	P6 value	Bed 6 Pressure	bar	H		55.2 *	2.07	55.2 *
SM050540	P7 value	HPSB pressure	bar	S		53.8	2.7	53.8
SM050540	P7 value	HPSB pressure	bar	H		55.2 *	3	55.2 *
SM051540	P8 value	LPSB Pressure	bar	S		1.6 **		
SM052540	voltage 28v	primary 28V/20A Voltage	V	H	23	31		
SM052540	voltage 28v	primary 28V/20A Voltage	V	S	25	29		
SM053540	voltage 12v	Secondary 12V Voltage	V	H	10	14		
SM053540	voltage 12v	Secondary 12V Voltage	V	S	11	13		
SM054540	voltage 5v	Secondary 5V Voltage	V	H	4	6		
SM054540	voltage 5v	Secondary 5V Voltage	V	S	4.5	5.5		
SM055540	voltage 15v	Secondary 15V Voltage	V	H	13	17		
SM055540	voltage 15v	Secondary 15V Voltage	V	S	14	16		
SM056540	Voltage – 15v	Secondary -15V Voltage	V	H	-17	-13		
SM056540	Voltage – 15v	Secondary -15V Voltage	V	S	-16	-14		
SM101540	voltage 31v	Secondary 31V Voltage	V	H	27	35		
SM101540	voltage 31v	Secondary 31V Voltage	V	S	29	33		
SM058540	intensity H7	LPSB Heater Current	mA			N/A		
SM059540	intensity H21	Bed 1 gas gap Current	A	H	0***	0.9		
SM059540	intensity H21	Bed 1 gas gap Current	A	S		0.8		
SM060540	intensity H22	Bed 2 gas gap Current	A	H		0.9		
SM060540	intensity H22	Bed 2 gas gap Current	A	S		0.8		
SM061540	intensity H23	Bed 3 gas gap Current	A	H		0.9		
SM061540	intensity H23	Bed 3 gas gap Current	A	S		0.8		
SM062540	intensity H24	Bed 4 gas gap Current	A	H		0.9		



SM062540	intensity H24	Bed 4 gas gap Current	A	S		0.8
SM063540	intensity H25	Bed 5 gas gap Current	A	H		0.9
SM063540	intensity H25	Bed 5 gas gap Current	A	S		0.8
SM064540	intensity H26	Bed 6 gas gap Current	A	H		0.9
SM064540	intensity H26	Bed 6 gas gap Current	A	S		0.8
SM065540	intensity H31	Nominal LR3 heater Current	mA	H		100
SM065540	intensity H31	Nominal LR3 heater Current	mA	S		70
SM066540	intensity H32	Redondant LR3 heater Current	mA	H		100
SM066540	intensity H32	Redondant LR3 heater Current	mA	S		70
SM071540	T cold face	SCE temperature	K	H	253	323
SM071540	T cold face	SCE temperature	K	S	263	313
SM072540	T warmest face	SCE temperature	K	H	253	333
SM072540	T warmest face	SCE temperature	K	S	263	323
SM073540	T warm face	SCE temperature	K	H	253	353
SM073540	T warm face	SCE temperature	K	S	263	343

Figure A3-39: Monitoring limits for physical parameters

* 55.2 = =800 psi. Switch off of the 20 A is requested at this limit (53.8 = 780 psi)

** = 1200 Torr

***: These low limits are for parameters which don't have in fact physical low limit. This is not acceptable as if no low limit is set in OCP/OCF entries, SCOS EGSE set it to 0, which could not be in the corresponding calibration curve. So values are defined as:

- 0 for pressure sensors, even if it is out of limit
- those extracted from the Figure A3-30 for parameter whose numerical calibration curves depends on the used equipment
- the minimum value of the calibration curve, when it is a numerical one
- 0 if the calibration curve is a polynomial one

****: except in the startup mode, in which no monitoring limit is applied

For intensities in Gas-Gap, other limits have been implemented using synthetic parameters:

Soft limits: [0 ; 0.1] and [0.5 ; 0.8] and Hard limits: [0 ; 0.2] and [0.4 ; 0.9], see section A3.3.1.3 for more details.



A3.6 Displays – DPF, DPC, GPF, GPC, SPF and SPC tables

The following sections describe the tables related to the definition of monitoring displays (Alphanumeric, Graphical and Scrolling). Note that the values of parameters appearing on these displays are only the ones extracted from fixed packets using the PLF table. The values extracted out of TM variable packets can only be displayed/printed using the VPD application.

A3.6.1 Alphanumeric displays – DPF and DPC tables

The DPF table contains the list of Alphanumeric Displays (32 or 64 parameter displays). One record is needed per display.

The DPC table contains the list of parameters to be displayed in each AND and their position. One record is needed per displayed parameter.

In alphanumeric displays, almost all parameters are defined, not only physical values as for graphical and scrolling displays. In this section will be discussed all alphanumeric displays which are not defined for the Lookup Table purpose, as a special section has been created for them (Appendix 1).

Here are the SCE numerical displays (DPF_TYPE = '1' for 32 parameters display and DPF_TYPE = '3' for 64 parameters display):

Name (DPF_NUMBE)	Description (DPF_HEAD)	DPF_TYPE
SA005540	EQUIPMENT AND CALIBRATION	1
SA006530	TM 1 - REPORT	1
SA010530	HSK1 – BOOT	1
SA011559	HSK2_HSK3 1	3
SA012540	HSK2_HSK3 2	3
SA013540	HSK2_HSK3 PHYSICAL VALUES CAL	3
SA014540	HSK2_HSK3 LIMITS ON GAS GAP	1
SA021530	DIAG1 - BOOT	3
SA022530	DIAG2 - ASW	1
SA023530	DIAG3 - HEALTH CHECK	1
SA024530	DIAG4 - REGENERATION	1
SA060530	TM 5 - REPORT	1
SA061530	TM 6_10 - MEMORY CHECK	1
SA062530	TM 9_9 - TIME VERIFICATION	1
SA084530	DIAG1 - PM RAM 1	3
SA085530	DIAG1 - PM RAM 2	3
SA086530	DIAG1 - DM EEPROM 1	3
SA087530	DIAG1 - DM EEPROM 2	3
SA088530	DIAG2 - DM EEPROM 1	3
SA089530	DIAG2 - DM EEPROM 2	3
SA090559	HSK2_HSK3 - 16 BITS	1
SA091540	HSK2_HSK3 PHYSICAL VALUES UNCAL	3
SA092530	DIAG - 16 BITS	1

Figure A3-40: SCE alphanumeric displays



In almost all alphanumeric displays the APID is displayed as the first parameter. There is not a unique APID parameter extracted from all PID packet but there are several APID parameter, each one defined for a unique APID (for more detail, refer to Figure A3-16).

A3.6.1.1 Housekeeping displays in boot mode

For the housekeeping telemetries in the boot mode all data are contained in one 32 parameters alphanumeric display:

Name (DPF_NUMBE)	Description (DPF_HEAD)	DPF_TYPE
SA010530	HSK1 - BOOT	1

Figure A3-41: Alphanumeric displays for housekeeping telemetries in boot mode

In this AND there are two 16 bits parameters (SM700530 and SM701510), which are displayed at the bottom display. Other parameters are parameters extracted from them.



Figure A3-42: The SA010530 AND - Housekeeping in boot mode

As already explained in section A3.2.2, parameters which are in housekeeping in boot mode and in ASW modes have been separately defined. So the current state parameter in boot mode is SM702530 although it is SM732530 in ASW modes.



A3.6.1.2 Housekeeping displays in ASW mode

For the housekeeping telemetries in ASW modes all data are contained in three 64 parameters alphanumeric displays (SA011559, SA012540 and SA013540) and four others for more details:

Name (DPF_NUMBE)	Description (DPF_HEAD)	DPF_TYPE
SA005540	EQUIPMENT AND CALIBRATION	1
SA011559	HSK2_HSK3 1	3
SA012540	HSK2_HSK3 2	3
SA013540	HSK2_HSK3 PHYSICAL VALUES CAL	3
SA014540	HSH2_HSK3 LIMITS ON GAS GAP	1
SA090559	HSK2_HSK3 - 16 BITS	1
SA091540	HSK2_HSK3 PHYSICAL VALUES UNCAL	3

Figure A3-43: Alphanumeric displays for housekeeping telemetries in ASW mode

They can be divided in two parts:

- One part for parameters which are not link to physical sensors.
- Another part for parameters which are link to physical sensors.

A3.6.1.2.1 ANDs for parameters which are not link to physical sensors

This part is composed of seven main parameters:

- 'Operating mode status', one 16 bits parameter,
- 'Faults status OBSW', one 16 bits parameter,
- 'Faults status SCE', one 16 bits parameter,
- 'Device status', five 16 bits parameters,
- 'Beds status MSB', one 16 bits parameter,
- 'Beds status LSB', one 16 bits parameter
- and 'Fixed heaters activity', two 16 bits parameters.

All this 16 bits parameters are displayed in the SA090559 AND (see Figure A3-44). This display is not the most interesting one because all these parameters have an internal structure and it is the parameters inside them which are the more understandable parameters. These 'more precise' parameters are displayed in two ANDs: SA011530 (see Figure A3-45) and SA012530 (see Figure A3-46).



NAME	DESCRIPTION	VALUE	UNIT	VALIDITY	DDL	FKT	MNEMONIC	SCC	SAMPLE TIME
SM671530APID	HSK2_3	NOMINAL		VALID	NOM	HSK2/HSK3		514	2006_094_10_33_17_950
SM739530MODE	STATUS	3	RAW	VALID	NOM	HSK2/HSK3		514	2006_094_10_33_17_950
SM731530FAULT	STATUS	00	RAW	VALID	NOM	HSK2/HSK3		514	2006_094_10_33_17_950
SM700540FULT	STATUS	0	RAW	VALID	NOM	HSK2/HSK3		514	2006_094_10_33_17_950
SM013540DEVICE	STATUS	1	RAW	VALID	NOM	HSK2/HSK3		514	2006_094_10_33_17_950
SM015540DEVICE	STATUS	3	RAW	VALID	NOM	HSK2/HSK3		514	2006_094_10_33_17_950
SM016540DEVICE	STATUS	4	RAW	VALID	NOM	HSK2/HSK3		514	2006_094_10_33_17_950
SM017540DEVICE	STATUS	5	RAW	VALID	NOM	HSK2/HSK3		514	2006_094_10_33_17_950
SM061540DDG	STATUS	NOB	RAW	STATE	INVL	HSK2/HSK3		514	2006_094_10_33_17_950
SM062540BDS	STATUS	LSB	RAW	STATE	INVL	HSK2/HSK3		514	2006_094_10_33_17_950
SM063540FIXED HEATERS		1	RAW	VALID	NOM	HSK2/HSK3		514	2006_094_10_33_17_950
SM160540FIXED HEATERS		2	RAW	VALID	NOM	HSK2/HSK3		514	2006_094_10_33_17_950

Figure A3-44: The SA090559 AND – Housekeeping 16 bits parameters in ASW modes
In the Figure A3-44, some data are colored in gray: they are state invalid data, as these parameters are not valid in the mode the snapshot has been captured (for more details on parameters validity see section A3.2.1.5).

NAME	DESCRIPTION	VALUE	UNIT	NAME	DESCRIPTION	VALUE	UNIT
SM671530APID	HSK2_3	NOMINAL		SM805540ADC0	STATUS	NO ERROR	
SM650530SID_HSK		NON ESSENTIAL		SM806540ADC1	STATUS	NO ERROR	
SM732530CURRENT STATE	HEALTH MONITOR			SM807540H1	STATUS	NO ERROR	
SM735305 BEDS	OFF			SM808540H2	STATUS	NO ERROR	
SM7345304 BEDS	OFF			SM809540H3	STATUS	NO ERROR	
SM735530CURRENT PROCESS	NONE			SM810540H4	STATUS	NO ERROR	
SM737530DAC ERROR	NO ERROR			SM811540H5	STATUS	NO ERROR	
SM738530ADC NOMINAL BUS	NO ERROR			SM812540H6	STATUS	NO ERROR	
SM739530ADC NOMINAL OOR	NO ERROR			SM813540H21	STATUS	NO ERROR	
SM740530ADC REDUND BUSHY	NO ERROR			SM814540H22	STATUS	NO ERROR	
SM741530ADC REDUND OOR	NO ERROR			SM815540H23	STATUS	NO ERROR	
SM74253012 VOLTS ERROR	NO ERROR			SM816540H24	STATUS	NO ERROR	
SM74353028 VOLTS ERROR	NO ERROR			SM817540H25	STATUS	NO ERROR	
SM744530EEPROM WRITE	NO ERROR			SM818540H26	STATUS	NO ERROR	
SM7455301553 FAILURE	NO ERROR			SM819540H8	STATUS	NO ERROR	
SM746530WATCHDOG 1	NO ERROR			SM820540H33	STATUS	NO ERROR	
SM747530WATCHDOG 2	NO ERROR			SM821540H34	STATUS	NO ERROR	
SM748530ELECTRO OVER T1	NO ERROR			SM822540H35	STATUS	NO ERROR	
SM748530ELECTRO OVER T2	NO ERROR			SM823540H36	STATUS	NO ERROR	
SM750530LOOKUP_LOAD	NO ERROR			SM824540H11	STATUS	NO ERROR	
SM751530LOOKUP_CONTENT	NO ERROR			SM825540H12	STATUS	NO ERROR	
SM752530LOOKUP_ADDRESS	NO ERROR			SM826540H13	STATUS	NO ERROR	
SM800540NORMAL FAULT	NO ERROR			SM827540H14	STATUS	NO ERROR	
SM801540BED OVER TEMP	NO ERROR			SM828540H15	STATUS	NO ERROR	
SM802540BED OVER PRES	NO ERROR			SM829540H16	STATUS	NO ERROR	
SM803540LP5B OVER TEMP	NO ERROR			SM830540H7	STATUS	NO ERROR	
SM804540FPGA ERROR	NO ERROR			SM831540H31	STATUS	NO ERROR	
SM799540Error Internal	NO ERROR			SM832540H32	STATUS	NO ERROR	
				SM832540H11	STATUS	NO ERROR	
				SM833540T1	STATUS	NO ERROR	
				SM834540T2	STATUS	NO ERROR	
				SM835540T3	STATUS	NO ERROR	
				SM836540T4	STATUS	NO ERROR	

Figure A3-45: The SA011559 AND - Housekeeping in ASW modes (1)

In the Figure A3-45, one parameter can be detailed: SM650530, the 'SID_HSK'. Its value is the SID of the packet (2 or 3 in this case). It allows to distinct HSK2 packets (i.e. non essential housekeeping packets) and HSK3 packets (i.e. essential housekeeping packets).

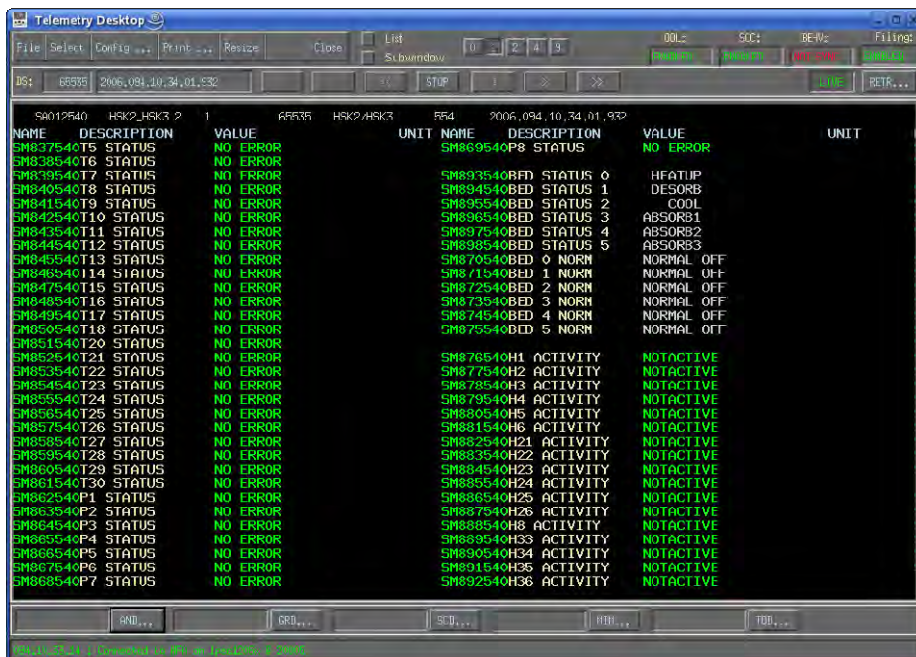

Figure A3-46: The SA012540 AND - Housekeeping in ASW modes (2)

A3.6.1.2.2 ANDs for parameters which are link to physical sensors

This part is also composed of seven types of parameters:

- 'Variable heaters values', nine 16 bits parameters,
- 'sensors value T1 to T30', twenty five 16 bits parameters,
- 'Sensor value P1 to P8', height 16 bits parameters,
- 'Voltage value', six 16 bits parameters,
- 'Intensity value', nine 16 bits parameters,
- 'Electronics T value', three 16 bits parameters
- and 'Reference sensors', four 16 bits parameters.

These 64 parameters are displayed in two ANDs

- SA013559, for calibrated values, of course the most important AND
- SA091559, for un calibrated values, this AND is for verification purpose only

In the Figure A3-47, two parameters triggered a soft out of limit as they are colored in yellow and several others triggered a hard out of limit, as they are colored in red.

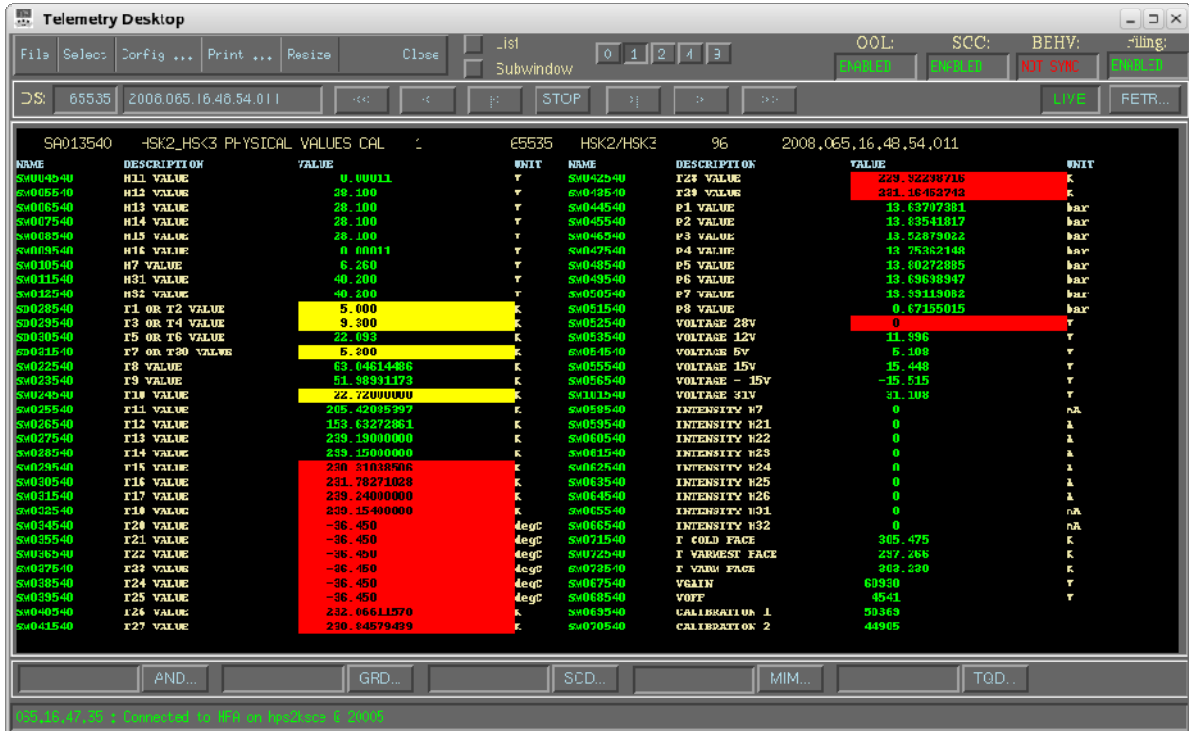

Figure A3-47: The SA013540 AND – Calibrated parameters from housekeeping in ASW modes

The Figure A3-48 is an example of a SA091559 AND, in which not valid parameters can be visualized, in gray color.

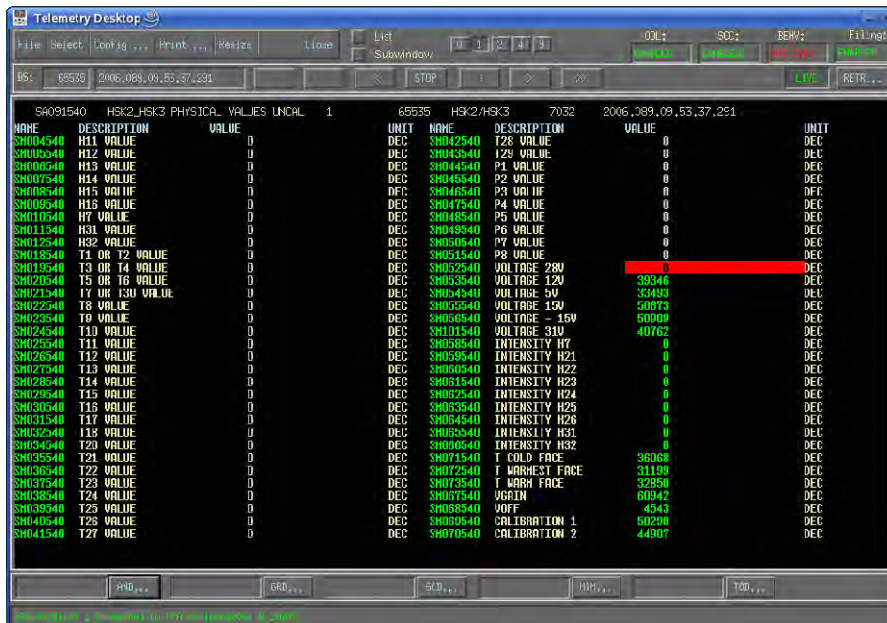

Figure A3-48: The SA091559 AND – Uncalibrated parameters from housekeeping in ASW modes



Another AND is related to parameters associated to physical sensors: the SA014559 AND (see Figure A3-49) which contains 12 specific synthetic parameters: SD051540 to SD056540 and SD061540 to SD066540. They represent the out of limit of the intensities in the gas-gap H21 to H26 (for more details, see section A3.3.1.3 and Figure A3-39). SD051540 to SD056540 are designed to be understandable, with a textual calibration although SD061540 to SD066540 are designed to trigger out of limits.

NAME	DESCRIPTION	VALUE	UNIT	VALIDITY	OOL	PKT	MNEHONIC	SSC	SAMPLE TIME
SD061540	INT H21 OOL TXT	NOT OOL		VALID	NOM	None			2006.198.13.43.31.175
SD062540	INT H22 OOL TXT	NOT OOL		VALID	NOM	None			2006.198.13.43.31.175
SD063540	INT H23 OOL TXT	HARD OOL		VALID	NOM	None			2006.198.13.43.31.175
SD064540	INT H24 OOL TXT	NOT OOL		VALID	NOM	None			2006.198.13.43.31.175
SD065540	INT H25 OOL TXT	NOT OOL		VALID	NOM	None			2006.198.13.43.31.175
SD066540	INT H26 OOL TXT	SOFT OOL		VALID	NOM	None			2006.198.13.43.31.175
SD051540	INT H21 OOL	0		VALID	NOM	None			2006.198.13.43.31.175
SD052540	INT H22 OOL	0		VALID	NOM	None			2006.198.13.43.31.175
SD053540	INT H23 OOL	2		VALID	OOL	None			2006.198.13.43.31.175
SD054540	INT H24 OOL	0		VALID	NOM	None			2006.198.13.43.31.175
SD055540	INT H25 OOL	0		VALID	NOM	None			2006.198.13.43.31.175
SD056540	INT H26 OOL	1		VALID	WARN	None			2006.198.13.43.31.175

Figure A3-49: The SA014559 AND - Monitoring limits for gas gap

Another important AND is the SA005540 one, represented on the Figure A3-50. It contains all details concerning the choice of conditional calibration curves, according to the used equipments: used cooler and possible use of a spare electronic system (for more details, see section A3.3.1.3).

NAME	DESCRIPTION	VALUE	UNIT	VALIDITY	OOL	PKT	MNEHONIC	SSC	SAMPLE TIME
SD096540	SPARE NOMINAL	TRUE		VALID	NOM	None			2006.198.13.43.31.175
SD097540	SPARE REDUNDANT	FALSE		VALID	NOM	None			2006.198.13.43.31.175
SD099540	COOLER	NOMINAL		VALID	NOM	None			2006.198.13.43.31.175
SD094540	CALIBRATION TXT	PFH2		VALID	NOM	None			2006.198.13.43.31.175
SD095540	CALIBRATION	4		VALID	NOM	None			2006.198.13.43.31.175

Figure A3-50: The SA005540 AND – Equipment and Calibration

A3.6.1.3 Diagnostic displays in boot mode

For diagnostic in the boot mode, all data is available from one AND: SA021530. Others display more detailed information.

Name (DPF_NUMBE)	Description (DPF_HEAD)	DPF_TYPE
SA021530	DIAG1 – BOOT	3
SA084530	DIAG1 - PM RAM 1	3



SA085530	DIAG1 - PM RAM 2	3
SA086530	DIAG1 - DM EEPROM 1	3
SA087530	DIAG1 - DM EEPROM 2	3
SA092530	DIAG - 16 BITS	1

Figure A3-51: Alphanumeric displays for Diagnostic telemetries in boot mode

Diagnostic in the boot mode is composed of height types of parameters:

- 'Diagnostic 1553', one 16 bits parameters,
- 'Diagnostic FPGA', one 16 bits parameters,
- 'Diagnostic PM Prom', one 16 bits parameters,
- 'Diagnostic PM RAM', one hundred and twenty height 16 bits parameters,
- 'PM RAM bad address', thirty 16 bits parameters,
- 'Diagnostic DM RAM', one 16 bits parameters,
- 'Diagnostic DM EEPROM', one hundred and twenty height 16 bits parameters,
- and 'Tranfert ASW result', one 16 bits parameters.

A summary for all data is the SA021530 AND (see Figure A3-52). It contains all detailed parameters for all 16 bits parameters except the 256 parameters of diagnostic DM EEPROM and PM RAM. A summary for these values is made by two synthetic parameters: SD000530 ('PM RAM NB ERROR') and SD001530 ('DM EEPROM ERROR'). So with this AND you have an overview of all needed data from diagnostic packets in the boot mode.



Figure A3-52: The SA021530 AND - Diagnostic in boot mode

Figure A3-53 and Figure A3-54 are examples of diagnostic PM RAM and diagnostic DM EEPROM. These data are displayed in four ANDs and need to be visualized only if SD000530 or SD001530 is not zero.



Figure A3-53: The SA084530 AND – Diagnostic for PM RAM

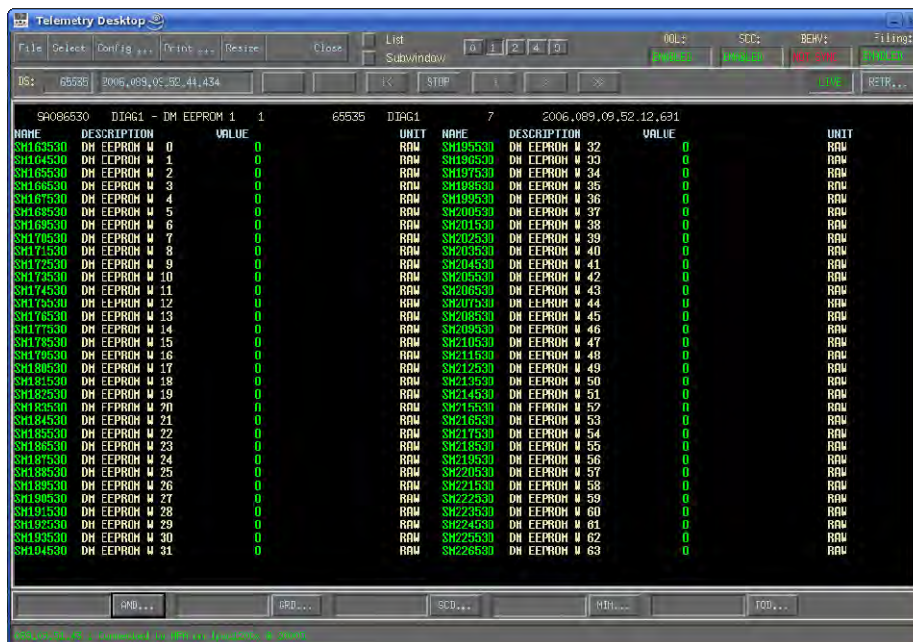

Figure A3-54: The SA086530 AND - Diagnostic for EEPROM in boot mode

The SA092530 AND (see Figure A3-55) allows to visualize almost all 16 bits parameters for all modes (boot or ASW modes), except of course the 256 ones for PM RAM and DM EEPROM.



Figure A3-55: The SA092530 AND - Diagnostic 16 bits parameters

A3.6.1.4 Diagnostic displays in ASW mode

For diagnostic in ASW modes, all data is available from one AND: SA022530 for 'generic' diagnostic. SA023530 and SA024530 ANDs are specific for the health check and the regeneration modes. Others display more detailed information.

Name (DPF_NUMBE)	Description (DPF_HEAD)	DPF_TYPE
SA022530	DIAG2 – ASW	1
SA023530	DIAG3 - HEALTH CHECK	1
SA024530	DIAG4 - REGENERATION	1
SA088530	DIAG2 - DM EEPROM 1	3
SA089530	DIAG2 - DM EEPROM 2	3
SA092530	DIAG - 16 BITS	1

Figure A3-56: Alphanumeric displays for diagnostic telemetries in ASW mode

Diagnostic in ASW modes is composed of three types of parameters:

- 'Diagnostic PM Prom', one 16 bits parameters,
- 'Diagnostic DM EEPROM', one hundred and twenty eight 16 bits parameters,
- and 'Diagnostic external timers', one 16 bits parameters.

A summary for all data is the SA022530 AND (see Figure A3-57). It contains all detailed parameters for all 16 bits parameters except the 128 parameters of diagnostic DM EEPROM. A summary for these values is made by the synthetic parameters SD002530 ('DM EEPROM ERROR'). So with this AND you have an overview of all needed data from diagnostic packets in the boot mode.

16 bits parameters can again be visualized in the SA092530 AND (see Figure A3-55), except of course the 128 ones for DM EEPROM.



NAME	DESCRIPTION	VALUE	UNIT	VALIDITY	OOL	PKT MNEMONIC	SSC	SAMPLE TIME
SM673530	APID DIAG2	NOMINAL		VALID	NOM	DIAG2	1	2006.094.09.58.22.826
SM800530	DIAG PM PROM	ERROR		VALID	OOL	DIAG2	1	2006.094.09.58.22.826
SD002530	DM EEPROM ERROR	0		VALID	NOM	None		2006.094.10.34.28.347
SM576530	TIMER 1	NO ERROR		VALID	NOM	DIAG2	1	2006.094.09.58.22.826
SM577530	LIREK 2	NO ERROR		VALID	NOM	DIAG2	1	2006.094.09.58.22.826
SM578530	TIMER 3	NO ERROR		VALID	NOM	DIAG2	1	2006.094.09.58.22.826
SM579530	TIMER 4	NO ERROR		VALID	NOM	DIAG2	1	2006.094.09.58.22.826
SM580530	TIMER 5	NO ERROR		VALID	NOM	DIAG2	1	2006.094.09.58.22.826
SM581530	TIMER 6	NO ERROR		VALID	NOM	DIAG2	1	2006.094.09.58.22.826
SM582530	TIMER 7	NO ERROR		VALID	NOM	DIAG2	1	2006.094.09.58.22.826
SM583530	TIMER 8	NO ERROR		VALID	NOM	DIAG2	1	2006.094.09.58.22.826
SM584530	TIMER 9	NO ERROR		VALID	NOM	DIAG2	1	2006.094.09.58.22.826
SM585530	FPGA TIMER	NO ERROR		VALID	NOM	DIAG2	1	2006.094.09.58.22.826

Figure A3-57: The SA022530 AND - Diagnostic in ASW mode

The SA023530 AND (see Figure A3-58) is designed for the Health check diagnostic and the SA024530 AND (see Figure A3-59) is designed for the Regeneration diagnostic.

NAME	DESCRIPTION	VALUE	UNIT	VALIDITY	OOL	PKT MNEMONIC	SSC	SAMPLE TIME
SM674530	APID DIAG3	NOMINAL		VALID	NOM	DIAG3	3	2006.089.09.56.11.549
SM675530	HC TEST 1	*****		NO	ERR	DIAG3	3	2006.089.09.56.11.549
SM676530	HC TEST 2	NO ERROR		VALID	NOM	DIAG3	3	2006.089.09.56.11.549
SM677530	HC TEST 3	NO ERROR		VALID	NOM	DIAG3	3	2006.089.09.56.11.549
SM678530	HC TEST 4	NO ERROR		VALID	NOM	DIAG3	3	2006.089.09.56.11.549
SM679530	HC TEST 5	NO ERROR		VALID	NOM	DIAG3	3	2006.089.09.56.11.549
SM680530	HC TEST 6	NO ERROR		VALID	NOM	DIAG3	3	2006.089.09.56.11.549
SM681530	HC TEST 7	NO ERROR		VALID	NOM	DIAG3	3	2006.089.09.56.11.549
SM682530	HC TEST 8	NO ERROR		VALID	NOM	DIAG3	3	2006.089.09.56.11.549
SM683530	HC TEST 9	NO ERROR		VALID	NOM	DIAG3	3	2006.089.09.56.11.549
SM684530	HC TEST 10	NO ERROR		VALID	NOM	DIAG3	3	2006.089.09.56.11.549
SM685530	HC TEST 11	NO ERROR		VALID	NOM	DIAG3	3	2006.089.09.56.11.549
SM686530	HC TEST 12	NO ERROR		VALID	NOM	DIAG3	3	2006.089.09.56.11.549
SM687530	HC TEST 13	NO ERROR		VALID	NOM	DIAG3	3	2006.089.09.56.11.549
SM688530	HC TEST 14	NO ERROR		VALID	NOM	DIAG3	3	2006.089.09.56.11.549
SM689530	HC TEST 15	NO ERROR		VALID	NOM	DIAG3	3	2006.089.09.56.11.549
SM690530	HC TEST 16	NO ERROR		VALID	NOM	DIAG3	3	2006.089.09.56.11.549
SM691530	HC TEST 17	NO ERROR		VALID	NOM	DIAG3	3	2006.089.09.56.11.549
SM692530	HC TEST 18	NO ERROR		VALID	NOM	DIAG3	3	2006.089.09.56.11.549
SM693530	HC TEST 19	NO ERROR		VALID	NOM	DIAG3	3	2006.089.09.56.11.549
SM694530	HC TEST 20	NO ERROR		VALID	NOM	DIAG3	3	2006.089.09.56.11.549
SM695530	HC TEST 21	NO ERROR		VALID	NOM	DIAG3	3	2006.089.09.56.11.549
SM696530	HC TEST 22	NO ERROR		VALID	NOM	DIAG3	3	2006.089.09.56.11.549
SM697530	HC TEST 23	NO ERROR		VALID	NOM	DIAG3	3	2006.089.09.56.11.549
SM698530	HC TEST 24	NO ERROR		VALID	NOM	DIAG3	3	2006.089.09.56.11.549
SM699530	HC TEST 25	NO ERROR		VALID	NOM	DIAG3	3	2006.089.09.56.11.549
SM700530	HC TEST 26	NO ERROR		VALID	NOM	DIAG3	3	2006.089.09.56.11.549
SM701530	HC TEST 27	NO ERROR		VALID	NOM	DIAG3	3	2006.089.09.56.11.549
SM702530	HC TEST 28	NO ERROR		VALID	NOM	DIAG3	3	2006.089.09.56.11.549
SM703530	HC TEST 29	NO ERROR		VALID	NOM	DIAG3	3	2006.089.09.56.11.549

Figure A3-58: The SA023530 AND - Health Check diagnostic



Figure A3-59: The SA024530 AND - Regeneration diagnostic

A3.6.1.5 Other displays

Name (DPF_NUMBE)	Description (DPF_HEAD)	DPF_TYPE
SA006530	TM 1 - REPORT	1
SA060530	TM 5 - REPORT	1
SA061530	TM 6_10 - MEMORY CHECK	1
SA062530	TM 9_9 - TIME VERIFICATION	1

Figure A3-60: Alphanumeric displays for other telemetries

A3.6.1.5.1 AND for telemetries service 1

All information extracted from telemetries of service 1 is one of the following for the SCE system (see ref AD07]):

- # Telecommand Packet ID, a copy of the TC Packet ID, which depends in fact only of the APID value
- # Telecommand Sequence Control, a copy of the TC Packet Sequence Control
- # Failure code

The SA006530 AND (see Figure A3-62) allow to visualize these information in a 5 blocks view, one view for Acceptance Success report, one for Acceptance Failure report, one for Execution Started Report, one for Execution Completed report and another one for Execution Failure report.

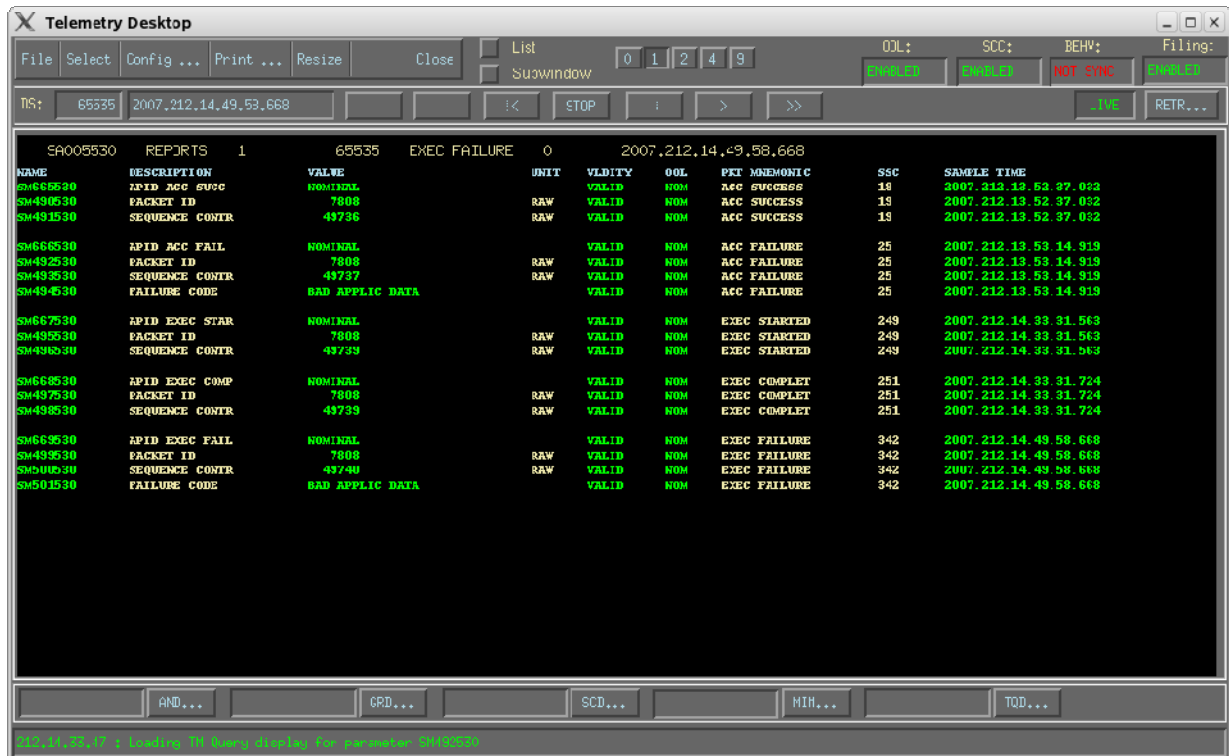

Figure A3-61: The SA006530 AND – service 1 report

A3.6.1.5.2 AND for telemetries service 5

All information extracted from telemetries of service 5 is one of the following for the SCE system (see ref AD07]):

Event ID	Description	Report type
1	Boot mode entered	Event
2	Init mode entered	Event
3	Ready mode (Health monitor) entered	Event
4	Ready mode (Health Check) entered	Event
5	Ready mode (Regeneration) entered	Event
6	Run mode (startup) entered	Event
7	Run mode (defrost) entered	Event
8	Run mode (normal) entered	Event
9	Shutdown mode entered	Event
10 (4)	Bed number change	Exception
11	Switch Off	Error

The SA060530 AND (see Figure A3-62) allow to visualize these information in a 3 blocks view, one view for event report, one for exception report and another one for error report. In a telemetry of service 5 are also defined a 16 bits SID parameter and a 64 bits parameters. They are always 0 for the SCE system. They are anyway displayed for a verification purpose.



NAME	DESCRIPTION	VALUE	UNIT	VALIDITY	OOL	PKT MNEMONIC	SSC	SAMPLE TIME
SM675530	RPID EVENT	NOMINAL		VALID	NOM	EVENT REPORT	13248	2006.338.15.59.00.794
SM311530	EVENT ID report	HEALTH MONITOR		VALID	NOM	EVENT REPORT	13248	2006.338.15.59.00.794
SM317530	EVENT SEQ COUNT	133	RAW	VALID	NOM	EVENT REPORT	13248	2006.338.15.59.00.794
SM312530	SID TM5 report	0	RAW	VALID	NOM	EVENT REPORT	13248	2006.338.15.59.00.794
SM313530	PARAMETER A1 rep	0	RAW	VALID	NOM	EVENT REPORT	13248	2006.338.15.59.00.794
SM315530	PARAMETER A2 rep	0	RAW	VALID	NOM	EVENT REPORT	13248	2006.338.15.59.00.794
SM675530	RPID EXCEPTION					None		
SM488530	EVENT ID exc					None		
SM484530	EXCPD SEQ COUNT		RAW			None		
SM481530	SID TM5 exc		RAW			None		
SM482530	PARAMETER A1 exc		RAW			None		
SM483530	PARAMETER A2 exc		RAW			None		
SM677530	RPID SWAOR	NOMINAL		VALID	NOM	SWAOR REPORT	13238	2006.338.15.58.02.531
SM485530	EVENT ID error	SWITCH OFF		VALID	NOM	ERROR REPORT	13238	2006.338.15.58.02.531
SM489530	ERROR SEQ COUNT	5	RAW	VALID	NOM	ERROR REPORT	13238	2006.338.15.58.02.531
SM486530	SID TM5 error	0	RAW	VALID	NOM	ERROR REPORT	13238	2006.338.15.58.02.531
SM487530	PARAMETER A1 err	0	RAW	VALID	NOM	ERROR REPORT	13238	2006.338.15.58.02.531
SM488530	PARAMETER A2 err	0	RAW	VALID	NOM	ERROR REPORT	13238	2006.338.15.58.02.531

Figure A3-62: The SA060530 AND – service 5 report

A3.6.1.5.3 AND for telemetries service 6 subtype 10

The SA061530 AND (see Figure A3-63) allows visualizing the result of a command (type 6, subtype 9): ‘Check Memory Using Absolute Address’

NAME	DESCRIPTION	VALUE	UNIT	VALIDITY	OOL	PKT MNEMONIC	SSC	SAMPLE TIME
SM673530	RPID MEMORY	NOMINAL		VALID	NOM	MEMORY CH AB	1	2006.089.08.58.13.700
SM303530	MEMORY ID	DM EEPROM 2		VALID	NOM	MEMORY CH AB	1	2006.089.08.58.13.700
SM304530	START ADDRESS	0	RAW	VALID	NOM	MEMORY CH AB	1	2006.089.08.58.13.700
SM305530	LENGTH	2	RAW	VALID	NOM	MEMORY CH AB	1	2006.089.08.58.13.700
SM306530	CHECKSUM	15502	RAW	VALID	NOM	MEMORY CH AB	1	2006.089.08.58.13.700

Figure A3-63: The SA061530 AND - Memory check

A3.6.1.5.4 AND for telemetries service 9 subtype 9

The SA061530 AND (see Figure A3-64) allows visualizing the result of a command (type 7, subtype 9): ‘Enable Time Verification’. The central time reference is displayed in the absolute time CUC format (4 bytes coarse time and 2 bytes fine time).

In the above example 2006.089.08.58.51.494 means the 89 day of year 2006, that is to say Thursday March 30, 2006, at 8h 58 min 51 s and 494 ms.



Figure A3-64: The SA062530 AND - Time verification

A3.6.2 Graphical displays – GPF and GPC tables

The GPF table contains the list of Graphic Displays (GRDs). One record is needed per graphical display.

The GPC table contains the list of parameters to be displayed in each GRD. One record is needed per displayed parameter.

In graphical displays, only parameters which are physical values are defined. Engineering values are displayed, not raw values (they are all associated to one numerical calibration curve).

NAME (GPF_NUMBE)	Description (GPF_HEAD)	Associated sensors	Number of plots
SG100540	PRESSURES	P1 to P8	8
SG101540	COLD END TEMPERATURES	(T1 or T2), (T3 or T4), (T5 or T6) and (T7 or T30)	4
SG102540	BEDS TEMPERATURES	T20 to T25	6
SG103540	LPSB TEMPERATURES	T17 and T18	2
SG104540	PRE-COOLER TEMPERATURES	T8 to T12	5
SG105540	VOLTAGES	28V, 12V, 5V, 15V, -15V and 31V	6
SG106540	H21 H22 H23 H24 H25 H26 INTENSITY	H21 to H26	6
SG107540	H7 H31 H32 INTENSITY	H7, H31 and H32	3
SG108540	SCE TEMPERATURES	COLD, WARMEST and WARM FACE	3
SG109540	HPST TEMPERATURES	T13 and T14	2
SG110540	BED HOUSING TEMPERATURES	T15, T16 and T26 to T29	6
SG111540	VARIABLE HEATERS VALUES 1	H11 to H16	6
SG112540	VARIABLE HEATERS VALUES 2	H7, H31 and H32	3

Figure A3-65: Graphical displays

For all graphical displays, GPF_TYPE is 'F', that is to say a full screen with a maximum of 8 plots against time.



For graphical displays, minimum and maximum values (GPC_MINIM and GPC_MAXIM fields) must be defined in the GPC table for each parameter. This value will not be editable by the SCOS 2000 user. If he wants to customize graphical views, the GRAPHS SCOS 2000 editor is available.

So graphs in the GPF and GPC tables are in fact a minimum base for graphical views, as range modifications are not available within SCOS 2000.

Sensor	Unit	Minimum value	Maximum value
T1 or T2	K	5	240
T3 or T4	K	5	200
T5 or T6	K	5	50
T7 or T30	K	5	260
T8 and T9	K	10	500
T10	K	10	400
T11	K	15	500
T12	K	40	500
T13,T14,T17,T18	K	230	380
T15,T16,T26,T27,T28,T29	K	210	360
T20 to T25	degC	-40	500
P1-P7	Bar	0	70
P8	Bar	0	3.5
Intensity in Gas-Gap H21 to H26	Amperes	0	2
Intensity in LPSB H7	mAmperes	0	1000
Intensity in H31 and H32	mAmperes	0	100
Tension 28V_20A	Volts	0	30
Tension 12V	Volts	0	20
Tension 5V	Volts	0	10
Tension +15V	Volts	0	20
Tension -15V	Volts	-20	0
Tension 31V	Volts	0	50
SCE Temperatures	K	240	360
Voltage on heaters H11 to H16	Volts	0	30
Voltage on heater H7	Volts	0	15
Vltage on heaters H31 and H32	Volts	0	41

Figure A3-66: Parameter values ranges in graphical displays

A3.6.3 Scrolling displays – SPF and SPC tables

The SPF table contains the list of Scrolling Displays (SCDs). One record is needed per scrolling display.

The SPC table contains the list of parameters to be displayed in each SCD. One record is needed per displayed parameter.

In scrolling displays, only parameters which are physical values are defined. Engineering values are displayed, not raw values (they are all associated to one numerical calibration curve).



There are more scrolling displays than graphical displays because the maximum of displayed parameters in one display is 5 in scrolling views instead of 8 in graphical views.

NAME (SPF_ NUMBE)	Description (SPF_HEAD)	Associated sensors	Number of values
SL100540	PRESSURES 1	P1 to P5	5
SL101540	PRESSURES 2	P6 to P8	3
SL102540	COLD END TEMPERATURES	(T1 or T2), (T3 or T4), (T5 or T6) and (T7 -> T30)	4
SL103540	BEDS TEMPERATURES 1	T20 to T22	3
SL104540	BEDS TEMPERATURES 2	T23 to T25	3
SL105540	LPSB TEMPERATURES	T17 and T18	2
SL106540	PRE-COOLER TEMPERATURES	T8 to T12	5
SL107540	VOLTAGES 1	28V, 12V, 5V	3
SL108540	VOLTAGES 2	15V, -15V and 31V	3
SL109540	H21 H22 H23 H24 H25 INTENSITY	H21 to H25	5
SL110540	H26 H7 H31 H32 INTENSITY	H26, H7, H31 and H32	4
SL111540	SCE TEMPERATURES	COLD, WARMEST and WARM FACE	3
SL112540	HPST TEMPERATURES	T13 and T14	2
SL113540	BED HOUSING TEMPERATURES 1	T15and T16	2
SL114540	BED HOUSING TEMPERATURES 2	T26 to T29	4
SL115540	VARIABLE HEATERS VALUES 1	H11 to H15	5
SL116540	VARIABLE HEATERS VALUES 2	H16, H7, H31 and H32	4

Figure A3-67: Scrolling displays



A4 Commands part

Commands described in the MIB are completely described in the “*Planck Sorption Cooler Electronics TC and TM Structures*” document, ref. [AD07].

Commands described in this section are not for LUT purpose. The LUT commands are described in the specific section A5.

Commands sequences are not described as they are not used by the SCE system.

The most important entity in the database is the command definition (table CCF) which describes the contents of a command. A command has the following main relationships:

- A many-to-many relationship with command parameters (CPC). The mapping table (CDF) defines the location of each parameter instance in the application data field of any command. A command parameter (CPC) describes an individual part of a command’s contents, which define its characteristics and behavior once released to the spacecraft. A command parameter has the following relationships:
 - A many-to-1 relationship with numeric calibration curves (CCA). Each parameter may only reference one curve, but each curve is shareable amongst other parameters. Each curve contains 1 or more points (CCS).
 - A many-to-1 relationship with textual calibrations (or alias set) (PAF). Each parameter may only reference one alias set, but each set is shareable amongst other parameters. Each alias set contains 1 or more text points (PAS).
 - A many-to-1 relationship with range sets (PRF). Each parameter may only reference one range set, but each set is shareable amongst other parameters. Each range set contains 1 or more entries consisting of a min-max pair or a single discrete value (PRV).
- A 1-to-many relationship with PTV expressions (Pre Transmission Verification). Each PTV expression can only be referenced by one command, but a command can reference many expressions, each of which are ANDed together to form the validation criteria. If an expression is to be repeated for another command, it must be defined again.
- A many-to-many relationship with verification stages (CVS). This is because a command can reference many stages, but a stage is also shareable between many commands (therefore stages need only be defined once – as they contain a lot of information). A mapping table (CVP) is required which supports the relationship. Each stage based on monitoring parameters contains one or more expressions (CVE) which are logically ANDed together to form the verification criteria. The CVE table can also be used to specify the monitoring parameters which are affected by each command execution stage (used for status consistency checking).

A4.1 Packet headers – TCP, PCPC and PCDF tables

Characteristics and the structure of command packet headers are fully described in the TCP, PCPC and PCDF tables. These tables are the same for each instrument and are provided by Thalès.



A4.2 Commands – CCF, CDF and CPC tables

This section describes the tables related to the definition of commands (CCF table) and command parameters (CPC table). The structure of the command application data field is specified via the CDF table in a way which is compatible with the need to generate variable length commands. Each command element whose value requires editing and/or calibration and/or checking has to be defined as a command parameter. Command parameters can be re-used in many different command definitions.

Remark: only command parameter values (as opposed to fixed areas) are visible in the command history (fixed areas are only stored as part of the TC packet Hex dump).

A4.2.1 The CCF table

This table defines the characteristics of commands. One record per command is needed. All these commands are the same for the 4 different equipments (it is not the case for LUT commands) and are inside the 530 element.

CCF_CNAME	CCF_DESCR2	CCF_TYPE	CCF_STYPE	CCF_NPARS	CCF_ILSTAGE
SC000530	TC 8_4 - Transfert Applicative Software	8	4	3	A
SC001530	TC 8_4 - Test PM RAM	8	4	3	A
SC002530	TC 8_4 - Test DM RAM	8	4	3	A
SC003530	TC 8_4 - Test PM PROM	8	4	3	A
SC004530	TC 8_4 - Test DM EEPROM	8	4	3	A
SC005530	TC 8_4 - Go To Boot	8	4	3	A
SC006530	TC 8_4 - Go To Init	8	4	3	A
SC007530	TC 8_4 - Go To Ready - Health Monitor	8	4	3	A
SC008530	TC 8_4 - Go To Ready - Health Check	8	4	3	A
SC009530	TC 8_4 - Go To Ready - Regeneration	8	4	3	A
SC010530	TC 8_4 - Go To Run - Startup	8	4	3	A
SC011530	TC 8_4 - Go To Run - Defrost	8	4	3	A
SC012530	TC 8_4 - Go To Run - Normal	8	4	3	A
SC013530	TC 8_4 - Go To Shutdown	8	4	3	A
SC014530	TC 8_4 - Set initial Heatup Bed Position	8	4	4	A
SC015530	TC 8_4 - Set Bed State	8	4	5	A
SC016530	TC 8_4 - Set Device State	8	4	5	A
SC017530	TC 8_4 - Return to Initial Beds States	8	4	3	A
SC018530	8_4 Stop Process (applicative software transfer, memory access)	8	4	3	A
SC141530	TC 14_1 - Enable Generation of TM	14	1	4	A
SC142530	TC 14_2 - Disable Generation of TM	14	2	4	A
SC143530	TC 14_3 - Report Enabled TM Packet	14	3	0	A
SC162530	TC 6_2 - Load Memory Using Absolute Address	6	2	5	C
SC163530	TC 6_2 - Load Memory Using Absolute Address for OBSM	6	2	6	C



SC165530	TC 6_5 - Dump Memory Using Absolute Address	6	5	3	C
SC169530	TC 6_9 - Check Memory Using Absolute Address	6	9	3	C
SC171530	TC 17_1 - Perform Connection Test	17	1	0	A
SC194530	TC 9_4 - Enable Time Synchronisation	9	4	0	A
SC195530	TC 9_5 - Time Code	9	5	1	A
SC197530	TC 9_7 - Enable Time Verification	9	7	0	A

Figure A3-68: The SCE commands

Here are some comments on some characteristic of the SCE CCF fields' values:

- CCF_DESCR2 is the detailed description although CCF_DESCR is a shorter description field
- CCF_TYPE is the service type of the command and CCF_STYPE the service subtype.
- CCF_APID is the APID of the command. It is always 1664 for the SCE system.
- CCF_RAPID is the redundant APID of the command. It is always null for the SCE system
- CCF_NPARS is the number of elements (i.e. parameters or fixed areas) associated with this command (in other words it is the total number of entries in the CDF table for this command). It is not the number of editable parameters.
- CCF_ILSTAGE is the default type of verification stage to which an interlock associated to this command waits on. For the SCE system only 'A' – Application acceptance and 'C' – Completion are used. This field is checked by the SCOS-2000 importer to avoid that a CEV Interlock Stage ('A' or 'C') is required for a command which does not foresee it in the CVP/CVS table. In case this would happen, CCF_ILSTAGE will be updated by the SCOS -2000 Importer by assigning the highest applicable level ('A' or 'O') for this command.
- CCF_ILSCOPE identifies the default interlock associated to this command when loading it on a SCOS-2000 command source. For the SCE system it is always set to 'L': the command will interlock only the local commanding source
- CCF_CRITICAL identifies the command 'criticality'. Note that the actual extra processing/protections required by critical commands is left up to mission specific implementation. For the SCE system it is always 'N' (not critical) except for:

Command name	Command description
SC016530	TC 8_4 - Set Device State
SC018530	8_4 Stop Process (applicative software transfer, memory access)
SC015530	TC 8_4 - Set Bed State
SC013530	TC 8_4 - Go To Shutdown

Figure A3-69: The SCE 'critical' commands

- CCF_SUBSYS is the identifier of the subsystem which the command belongs to, always 19 for the SCE system
- CCF_ACK is the Acknowledgement flag of the command, i.e. the integer value in decimal of the complete Ack field of the Packet Data Field Header. For the SCE system, it is acknowledge for TM(1, 1) for all command except for command of



service type 6 (memory management) for which it is acknowledge for TM (1, 3) and TM (1, 7).

Acknowledge for TM(1, 1) should correspond to the value 1 in the CCF_ACK, but due to a SCE NCR (NCR number NC-PSCB410-600090-LPSC), it corresponds to 1 for the applicative software and to 8 for the boot software. So for commands sent only from the boot mode ('Transfert ASW', 'Test PM RAM' and 'Test DM RAM') and the command 'Go To Init', which is sent more often from the boot mode than from the applicative software, it has been decided to set the acknowledge field of the CCF table to 8.

Command	CCF_ACK
TC (6, 2), TC (6, 5) and TC (6, 9)	10 – TM (1, 3) and TM (1, 7)
Transfert ASW Test PM RAM Test DM RAM Go To Init	8 – TM(1, 1)
All others	1 – TM (1, 1)

Figure A3-70: Acknowledgement flags for the SCE commands

A4.2.2 The CDF and CPC table

The CPC table defines the characteristics of command parameters. One record is needed per command parameter.

The CDF table defines the structure of the commands in terms of constituent elements. One record is needed per command element (i.e. parameter or fixed area).

A4.2.2.1 CPC_PTC and CPC_PFC Fields

CPC_PTC, the Parameter Type Code, controls the encoding format of the parameter and CPC_PFC, the Parameter Format Code, controls the length of the parameter, along with the Parameter Type Code. They are similar to the PCF_PTC and PCF_PFC fields of the PCF telemetry table.

In the SCE system, used combinations are:

PTC	PFC	S2K Parameter Type	Length	PUS type
3	0	Unsigned Integer	4 bits	Unsigned integer parameter
3	4	Unsigned Integer	8 bits	Unsigned integer parameter
3	8	Unsigned Integer	12 bits	Unsigned integer parameter
3	12	Unsigned Integer	16 bits	Unsigned integer parameter
7	0	Octet string	Variable	Variable length octet string
9	17	Absolute Time CUC format	48 bits	Absolute Time CUC format

Figure A3-71: CPC_PTC and CPC_PFC used in the SCE system



A4.2.2.2 Command parameter default values

A command parameter may be associated to a default value at each level of instantiation i.e. at the level of parameter definition itself (CPC_DEFVAL), at the level of command definition (i.e. when defining the structure of a command containing the parameter, CDF_VALUE) or at the level of sequences definition (not used in the SCE system). The same parameter can be re-used in several command definitions which on their turn can be re-used in several sequences definition. In order to enable a centralized maintenance of command parameter default values (whenever required), SCOS-2000 supports the ability to propagate default values from the lower to the higher levels of instantiation. This is achieved by providing the ability to refer to the default value specified at the previous instantiation level (option 'D' for fields CDF_INTER and SDF_VTYPE). This possibility is not used in the SCE system.

The CPC_DEFVAL and CDF_VALUE fields associate a static default value to each editable command element. In addition, SCOS-2000 provides the ability to override the static default with a 'dynamic default' value extracted from a monitoring parameter. This feature is not used in the SCE system.

In the SCE system, all default values are static ones, defined only in the CDF_VALUE field, except for SP020530 (the 'SPARE' parameter of the 'TC 6_2 - Load Memory Using Absolute Address' command) and SP000530 (the repeater 'N' of the 'TC 14_1 - Enable Generation of TM' and the 'TC 14_2 - Disable Generation of TM' commands) whose default values are defined in the CPC and CDF tables (with the same values).

A4.2.2.3 CDF_ELLEN and CDF_BIT fields

The CDF_ELLEN field specifies the length of the command element expressed in number of bits. For (fixed or editable) command parameters this field is not used by SCOS-2000 as the element length is derived from the PTC/PFC pair of the referenced parameter (CDF_PNAME). However, it is expected that this field is properly populated with the parameter length in order to be able to check the consistency of the commands and parameters definition.

The CDF_BIT field specifies the bit offset of this element relative to the start of the unexpanded command application data field (i.e. the end of the packet header, including the data field header where applicable, as specified in the PCDF table). The bit offset of command elements following a repeated group shall be calculated assuming no repetition (i.e. counters value = 1).

In the "Planck Sorption Cooler Electronics OBSW TC and TM Structures" (ref [AD07]), the structure of the commands of service type 8 subtype 4 is described as below:

Packet Header	Data Field Header		Application Data			
Packet Length	Packet Type	Packet Sub type	Function ID	Activity ID	SID	Parameters
16 bits	8 bits	8 bits	8 bits	8 bits	16 bits	n*16 bits

Figure A3-72: Structure of commands of service type 8 subtype 4

which is translated in the CDF MIB file as:



Parameter Name	CDF_ELLEN	CDF_BIT
Function ID	8	0
Activity ID	8	8
SID	16	16

Figure A3-73: CDF_ELLEN and CDF_BIT examples

A4.2.2.4 CPC_CATEG, CPC_CCAREF and CPC_PAFREF fields

The CPC_CATEG flag identifies the type of calibration associated to the parameter:

- 'C' – numeric calibration, therefore CPC_CCAREF shall not be null
- 'T' – textual calibration, therefore CPC_PAFREF shall not be null
- 'B' – both calibrations (not supported yet by SCOS-2000).
- 'N' – implies no calibration.

The CPC_CCAREF field contains the ID of an existing numeric calibration curve (link to CCA_NUMBR) and the CPC_PAFREF field contains the ID of an existing textual calibration (link to PAF_NUMBR).

In the SCE system, only textual calibrations are used for command, so CPC_CATEG is 'T' or 'N'. Defined textual calibrations are described in section A4.3.

A4.2.2.5 CPC_PRFREF field

This field contains the ID of an existing parameter range set (PRF_NUMBR) to which the parameter will be associated. The ranges defined within the set will determine the possible values for the parameter. Only one range is defined (see section A4.4) for the SCE system.

A4.2.2.6 Repeated Groups and the CDF_GRP_SIZE field

In order to satisfy all the possible command structures which are supported by PUS, the concept of repeated groups needs to be addressed. This is where certain parameters in the command may be repeated a variable number of times.

If a group of consecutive parameters may be repeated more than once, then a counter field parameter (typically named N or N1 etc.) must be present in the command before the start of the group. If this counter parameter can be identified and the size of the repeated group given, then the structure of the command can be reproduced.

If an element is a group repeater parameter, then the CDF_GRP_SIZE field's value is the number of following command elements belonging to the group to be repeated 'N' times at load-time. Otherwise its value has to be left Null or set to zero.

In the SCE system, two commands ('TC 14_1 - Enable Generation of TM' and 'TC 14_2 - Disable Generation of TM') have repeated groups. They use the same repeater parameter: SP000530, whose default value is 1. Its CDF_GRP_SIZE value is 3, as the structure of a command of service type 14 subtype 1 or 2 is (ref [AD07]):



A4.3 The PAF and the PAS tables

The PAF table defines the text (de-)calibration sets (also known as parameter alias sets). One record is needed per textual (de-)calibration set. The PAS table defines the text string/raw value pairs associated to a (de-)calibration set. One record is needed per alias/raw value pair.

In the SCE system, the textual calibrations are:

Identifier	Description	Values
322	MEMORY ID	DM RAM 1 / DM RAM 2 / DM EXTERNAL / DM FPGA 1 / DM FPGA 2 / DM EEPROM 1 / DM EEPROM 2 / DM EEPROM 3 / DM EEPROM 4 / DM EEPROM 5 / DM EEPROM 6 / DM EEPROM 7 / DM EEPROM 8 / PROM OR PMRAM / PM RAM (ASW) / PROM OR PMRAM / PM RAM (BOOT) / DM 1553
502	Bed State	BAD BED NORMAL MODE ONLY GOOD BED
503	Device Number	ADC0 / ADC1 / H23 / H24 / H25 / H26 / H8 / H33 / H34 / H35 / H36 / H11 / H1 / H12 / H13 / H14 / H15 / H16 / H7 / T1 / T2 / T3 / T4 / H31 / T5 / T6 / T7 / T8 / T9 / T10 / T11 / T12 / T13 / T14 / H32 / T15 / T16 / T17 / T18 / T20 / T21 / T22 / T23 / T24 / T25 / T26 / T27 / T28 / T29 / T30 / H2 / H3 / H4 / P1 / P2 / P3 / P4 / P5 / P6 / P7 / P8 / H5 / H6 / H21 / H22
504	Device Status	GOOD DEVICE BAD DEVICE

Figure A3-76: Textual calibration for the SCE command parameters

A4.4 The PRF and the PRV tables

The PRF and PRV tables define the data required to perform range checking of parameter values. They can be equally used for command as well as for sequence parameters. However, only parameters which in their raw representation are of a numerical nature or times can be range checked (i.e. strings cannot be range checked).

The PRF table describes the set of ranges which can be associated to a command or a sequence parameter. One record per range set.

The PRV table defines the allowed value ranges for the associated range set. One record per allowed (range of) value(s). The range check will be satisfied if the parameter value falls within or is equal to the min/max values. A set of allowed discrete values or value ranges can be defined by entering a record per allowed value (specified in PRV_MINVAL) or value range (specified in PRV_MINVAL and PRV_MAXVAL).

In the SCE system, only one range is defined, for parameters SP033530 ('Heatup Bed Position') and SP035530 ('Bed Number'). Its characteristics are:

PRF_NUMBR	PRF_DESCR	PRV_MINVAL	PRV_MAXVAL
1	Bed Position	0	5

Figure A3-77: Ranges in the SCE commands



A4.5 Summary of editable parameters in the SCE system

A4.5.1 Editable parameters of TC 8_4 - Set initial Heatup Bed Position

The only parameter is SP033530: '*Heatup bed position*', which specifies a bed number. It is an integer from 0 to 5.

A4.5.2 Editable parameters of TC 8_4 - Set Bed State

For this command, there are two parameters:

- SP034530: '*Bed State*', which is one of the following values:
 - o '*Bad Bed*'
 - o '*NORMAL MODE ONLY*'
 - o '*Good bed*'
- SP035530: '*Bed Number*', which specifies a bed number. It is an integer from 0 to 5.

A4.5.3 Editable parameters of TC 8_4 - Set Device State

For this command, there are two parameters:

- SP036530: '*Device Status*', which is one of the following values:
 - o '*Bad Device*'
 - o '*Good Device*'
- SP037530: '*Device Number*', which specifies one of the following devices: ADC0, ADC1, H23, H24, H25, H26, H8, H33, H34, H35, H36, H11, H1, H12, H13, H14, H15, H16, H7, T1, T2, T3, T4, H31, T5, T6, T7, T8, T9, T10, T11, T12, T13, T14, H32, T15, T16, T17, T18, T20, T21, T22, T23, T24, T25, T26, T27, T28, T29, T30, H2, H3, H4, P1, P2, P3, P4, P5, P6, P7, P8, H5, H6, H21 or H22

A4.5.4 Editable parameters of TC 14_1 and TC 14_2

TC 14_1: Enable Generation of TM

TC 14_2: Disable Generation of TM

For this command, there are at least four parameters:

- SP000530: '*N*', the repeater which specifies the number of TM packets definitions that follow (i.e. how much set of parameters Type, Sub Type and Packet ID will be entered)
- SP001530: '*Type*', the TM packet service type
- SP002530: '*Sub Type*', the TM Packet service subtype
- SP003530: '*Packet ID*':
 - o When packet-Id is zero, the whole family (packet type/subtype) is enabled.



- For housekeeping and diagnostic service 3, packet-ID is equal to HK packet-ID defined for that service.
- For Event reporting service 5, packet-Id is equal to event-ID defined for that service.

A4.5.5 Editable parameters of TC 6_2

TC 6_2: Load Memory Using Absolute Address

For this command, there are four parameters:

- SP010530: '*Memory ID*', which specifies the memory block in which data is uploaded. It is one of the following: DM RAM 1, DM RAM 2, DM EXTERNAL, DM FPGA 1, DM FPGA 2, DM EEPROM 1, DM EEPROM 2, DM EEPROM 3, DM EEPROM 4, DM EEPROM 5, DM EEPROM 6, DM EEPROM 7, DM EEPROM 8, PROM OR PMRAM, PM RAM (ASW), PROM OR PMRAM, PM RAM (BOOT) or DM 1553
- SP011530: '*Start Address*', it is the start address within selected the memory block in SAU (Smallest Addressable Unit). SCE SAU are defined in Figure A3-78.
- SP021530: '*Length*', Number of SAU to be loaded
- SP022530: '*Data Memory + Checksum*', data to be loaded + checksum of the data to be loaded

Memory ID	Memory addressed	SAU
0x9000	BOOT: PM PROM / ASW: PM RAM	48 bits
0x9001	ASW : PM RAM	48 bits
0x9080	BOOT: PM RAM / ASW: PM PROM	48 bits
0x9081	BOOT: PM RAM	48 bits
0x0	DM RAM 1	32 bits
0x1	DM RAM 2	32 bits
0x2000	DM 1553	32 bits
0x4000	DM External Timers	32 bits
0x4002	DM FPGA 1	32 bits
0x4004	DM FPGA 2	32 bits
0x8000	DM EEPROM 1	32 bits
0x8001	DM EEPROM 2	32 bits
0x8002	DM EEPROM 3	32 bits
0x8003	DM EEPROM 4	32 bits
0x8004	DM EEPROM 5	32 bits
0x8005	DM EEPROM 6	32 bits
0x8006	DM EEPROM 7	32 bits
0x8007	DM EEPROM 8	32 bits

Figure A3-78: Memory blocks and SAU

Remarks:

- The SP022530 command parameter is a variable length octet string and values of variable octet string parameters can only be loaded from a Stack Import file (i.e.



- they cannot be specified/edited on SCOS-2000 manual stacks). This implies that a load memory command can not be send via the SCOS 2000 Manual Stack, but always via a stack file.
- When using stack files, be very careful of the fact that numerical values (even if unsigned integer) **have always to be expressed in decimal**, whatever the value of the CPC_RADIX field is.
 - The checksum is calculated with a 16 bits Cyclic Redundancy Check code (CRC).

A4.5.6 Editable parameters of TC 6_2

TC 6_2: Load Memory Using Absolute Address for OBSM

This command is very similar to the previous one. It is designed to be used for the OBSM purpose. The difference is that the SP022530 parameter (*'Data Memory + Checksum'*) is split into two new parameters:

- SP023530, the data to be loaded
- SP024530, the checksum of the data to be loaded

A4.5.7 Editable parameters of TC 6_5 and TC 6_9

TC 6_5: Dump Memory Using Absolute Address

TC 6_9: Check Memory Using Absolute Address

For this command, there are three parameters:

- SP010530: *'Memory ID'*, which specifies the memory block in which upload data. It is one of the following: DM RAM 1, DM RAM 2, DM EXTERNAL, DM FPGA 1, DM FPGA 2, DM EEPROM 1, DM EEPROM 2, DM EEPROM 3, DM EEPROM 4, DM EEPROM 5, DM EEPROM 6, DM EEPROM 7, DM EEPROM 8, PROM OR PMRAM, PM RAM (ASW), PROM OR PMRAM, PM RAM (BOOT) or DM 1553
- SP011530: *'Start Address'*, it is the start address within selected the memory block in SAU (Smallest Addressable Unit). SCE SAU are defined in Figure A3-78.
- SP021530: *'Length'*, Number of SAU to be loaded

A4.5.8 Editable parameters of TC 9_5 - Time Code

The only parameter is SP040530: *'Time Used to Synchronize'*. It is an absolute time in the CUC format (4 bytes coarse time and 2 bytes fine time). For example 2006.089.08.58.51.494 means the 89 day of year 2006, that is to say Thursday March 30, 2006, at 8h 58 min 51 s and 494 ms.



A4.6 Pre-transmission verification – the PTV table

The PTV table describes which expressions are used by which commands to perform static PTV (Pre Transmission Verification). Multiple checks defined for a command are implicitly ANDed together and therefore only one instance of a PTV parameter should be defined per command.

Remark: the validity of the monitoring parameters used for command validation is implicitly taken into account by SCOS-2000 i.e. a PTV check is only passed if the validation parameter is valid and its value is as required.

The Figure A3-79 shows the conditions that enable to send all commands.

TC	Fct ID Act ID SID	Name	C1 (TC can be launched on the specified modes: 'X')										C2	C3
			Boot	Init	Health Monitor	Health Check	Regeneration	Startup	Defrost	Normal	Shutdown	Current Process =	ASW Transfer Status = 0 (*)	
TC(6,2)	None	Memory Load	X	X	X	X	X	X	X	X	X	X	X	
TC(6,5)	None	Memory Dump	X	X	X	X	X	X	X	X	X	X	X	
TC(6,9)	None	Memory Check	X	X	X	X	X	X	X	X	X	X	X	
TC(8, 4)	000	Transfer ASW	X										X	
TC(8, 4)	100	Test PM RAM	X										X	
TC(8, 4)	110	Test DM RAM	X										X	
TC(8, 4)	120	Test PM PROM	X	X									X	
TC(8, 4)	130	Test DM EEPROM	X	X									X	
TC(8, 4)	200	Go to Boot	X	X										
TC(8, 4)	210	Go to Init	X	X	X	X	X							X
TC(8, 4)	220	Go to Health Monitor		X	X	X	X	X	X	X	X			
TC(8, 4)	230	Go to Health Check			X									
TC(8, 4)	240	Go to Regeneration			X									
TC(8, 4)	250	Go to Startup			X			X	X	X				
TC(8, 4)	260	Go to Defrost						X						
TC(8, 4)	270	Go to Normal						X						
TC(8, 4)	280	Go to Shutdown			X	X	X	X	X	X	X			
TC(8, 4)	301	Set Initial Heatup bed position		X	X	X	X					X		
TC(8, 4)	310	Return to Initial Beds States		X	X	X	X					X		
TC(8, 4)	401	Set Bed State		X	X	X	X	X	X	X	X			
TC(8, 4)	501	Set Device State		X	X	X	X	X	X	X	X			
TC(8, 4)	600	Stop Process	X	X	X	X	X	X	X	X	X			
TC(9, 4)	None	Enable Time Synchronization	X	X	X	X	X	X	X	X	X			
TC(9, 5)	None	Time Code	X	X	X	X	X	X	X	X	X			
TC(9, 7)	None	Enable Time Verification	X	X	X	X	X	X	X	X	X			
TC(14, 1)	None	Enable Generation of TM Packets	X	X	X	X	X	X	X	X	X			
TC(14, 2)	None	Disable Generation of TM Packets	X	X	X	X	X	X	X	X	X			
TC(14, 3)	None	Report Enabled TM Packets	X	X	X	X	X	X	X	X	X			
TC(17, 1)	None	Perform Connection Test	X	X	X	X	X	X	X	X	X			

Figure A3-79: TC Conditions table



The following conditions are used:

- “C1” is the ‘*Current State*’, extracted from the ‘*Operating Mode Status*’ of TM (3, 25)
- “C2” is the ‘*Current Process*’, extracted from the ‘*Operating Mode Status*’ of TM (3, 25)
- “C3” is the ‘*Applicative Software Transfer Status*’, extracted from the ‘*Operating Mode Status*’ of TM (3, 25)

(*): applies to boot mode only.



A4.7 TC completion – the CVS, CVE and CVP tables

A complete description of the SCE TC responses is in the “*Planck Sorption Cooler Electronics OBSW TC and TM Structures*” document, ref [AD07], chapter 4 ‘*TC responses*’. A general view of the MIB implementation is given in the Figure A3-82.

SCOS-2000 supports two different types of verification checks:

- Report based i.e. based on dedicated TM packets reporting the successful or failed completion of a command execution stage
- Parameter based i.e. based on the check of the value of one or more monitoring parameters against a specified criteria

The characteristics of a verification stage are specified in the CVS table. Each command can be associated (in the CVP table) to several independent verification stages of different types. The verification stages based on parameter checks are associated to one or more verification criteria expressed in the CVE table.

A4.7.1 The CVS table

The verification stage table, CVS, defines the characteristics of a verification stage. One record is needed per verification stage. The same verification stages can be associated to several commands (in the CVP table).

The CVS_TYPE field specifies the stage in the command execution profile to which the verification stage is associated. In the SCE system, only ‘A’ the application acceptance, ‘S’ the start of execution and ‘C’ the completion of execution are used.

The CVS_SOURCE field identifies the type of verification check associated to the stage:

- ‘R’ if based on TM report packets
- ‘V’ if based on the check of monitoring parameter values against the criteria specified in the CVE table for the stage

The CVS_START field is the delta time after release (or execution for time tagged commands) before verification window opens. It is always 0 in the SCE system.

The CVS_INTERVAL field is the length of the sampling interval used to calculate the overall verification window, expressed in second.

All verification stages defined in the SCE system are defined in the Figure A3-80.



CVS_ID	Commands	CVS_SOURCE	CVS_TYPE	Description	CVS_INTERVAL (s)	
0001	All except memory commands	R	A	TM (1,1)	20	
0002	Memory commands		S	TM (1,3)	20	
0003	Memory commands		C	TM (1,7)	40	
0004	Transfert ASW	V	S	Current process = transfert ASW	20	
0005	Transfert ASW		C	Transfert ASW = transferred	80	
0006	Test PM RAM, PM PROM and EEPROM		S	Current process = test hardware	20	
0007	Go to boot		C		Current state = boot	40
0008	Go to init				Current state = init	40
0009	Go o ready (health monitor)				Current state = health monitor	40
0010	Go to ready (health check)				Current state = health check	40
0011	Go to ready (regeneration)				Current state = regeneration	40
0012	Go to run (startup)				Current state = startup	40
0013	Go to run (defrost)				Current state = defrost	40
0014	Go to run (normal)				Current state = normal	40
0015	Go to shutdown				Current state = shutdown	40
0020	All test memory					TM (3,26)
0021	Enable time verification				TM (9,9)	40
0022	Report Enabled packets				TM (14,4)	40
0023	Perform connection report			TM (17,2)	40	

Figure A3-80: SCE verification stages

A4.7.2 The CVP Table

The verification profiles table, CVP, describes which stages are applicable to which command/sequence, i.e. the verification profile of each task. One record per verification stage is attached to a command/sequence. Several verification stages can be associated to each command. However, only one verification stage for each CVS_TYPE is allowed (e.g. only one acceptance verification stage can be associated to a command).



A4.7.3 The CVE table

The verification expressions table, CVE, describes the different monitoring parameters and values used to build the verification criteria for any defined verification stage. One record per is needed verification check. Multiple checks associated to the same stage are implicitly ANDed together to form the overall verification criteria.

Remark: the validity of the monitoring parameters used for verification is implicitly taken into account by SCOS-2000 i.e. a verification check is only passed if the verification parameter is valid and its value satisfies the specified criterion.

The CVE_PARNAM field specifies the name of an existing monitoring parameter (PCF_NAME) to be used for the verification check. Any type of monitoring parameters can be used for the verification (TM parameters or synthetic parameters). However, only TM parameters whose raw representation is of numerical nature can be used.

The CVE_INTER field identifies the representation selected to specify the expected value (CVE_VAL) and the allowed tolerance (CVE_TOL) to be used for the verification check. It is always 'R' (raw representation) in the SCE system.

The SCE_VAL field contains the value that the verification parameter (CVE_PARNAM) must be compared against in order to perform the verification check. Raw values must be expressed in decimal.

The SCE_TOL field contains the allowed tolerance of the verification parameter value to satisfy the verification check (i.e. the value of CVE_PARNAM must fall within the range identified by CVE_VAL +/- CVE_TOL).

For the SCE system, the following entries have been defined (Figure A3-81):

CVE_ID	CVE_PARNAM	CVE_VAL	CVE_TOL	Description
From 4 to 15	SM502530	From 1 to 9	0	Verification on the change of value of the 'Current mode' parameter from housekeeping telemetries
20	SM799530	0	1	Verification on the reception of a telemetry on which there is a 'DIAG PM PROM' parameter inside (whatever the value is), i.e. a diagnostic packet
21	SM651530	2313	0	Verification on the reception of a telemetry of service type 9 subtype 9
22	SM652530	3588	0	Verification on the reception of a telemetry of service type 14 subtype 4
23	SM653530	4354	0	Verification on the reception of a telemetry of service type 17 subtype 2

Figure A3-81: The SCE CVE entries



Type, subtype	Func.ID Act. ID SID			Designation	Acceptance Report Based*	Started Report Based**	Completion Report Based***	Started TM based	Completion TM based
6,2				Load Memory		X	X		
6,5				Dump Memory		X	X		
6,9				Check Memory		X	X		
8,4	0	0	0	Transfer applicative software	X			Current process = transfert ASW (SM505530 = 1) – CVS_ID = 4	Transfert ASW = transferred (SM291530 = 0) – CVS_ID = 5
8,4	1	0	0	Test PM RAM	X			Current process = test hardware (SM505530 = 2) – CVS_ID = 6	TM (3,26) received test on Diag PM Prom (SM799530 = 0 or 1) – CVS_ID = 20
8,4	1	1	0	Test DM RAM	X				TM (3,26) received test on Diag PM Prom (SM799530 = 0 or 1) – CVS_ID = 20
8,4	1	2	0	Test PM PROM	X			Current process = test hardware (SM505530 = 2) – CVS_ID = 6	TM (3,26) received test on Diag PM Prom (SM799530 = 0 or 1) – CVS_ID = 20
8,4	1	3	0	Test DM EEPROM	X			Current process = test hardware (SM505530 = 2) – CVS_ID = 6	TM (3,26) received test on Diag PM Prom (SM799530 = 0 or 1) – CVS_ID = 20
8,4	2	0	0	Go to Boot	X				Current State = boot (SM502530 = 1) – CVS_ID = 7
8,4	2	1	0	Go to Init	X				Current State = init (SM502530 = 2) – CVS_ID = 8



Planck LFI
Sorption Cooler System
User Manual

Document No.: PL-LFI-PST-MA-002
 Issue/Rev. No.: 3.0
 Date: 20 March 2009

8,4	2	2	0	Go to Ready (Health Monitor)	X				Current State = health monitor (SM502530 = 3) – CVS_ID = 9
8,4	2	3	0	Go to Ready (Health Check)	X				Current State = health check (SM502530 = 4) – CVS_ID = 10
8,4	2	4	0	Go to Ready (Regeneration)	X				Current State = regeneration (SM502530 = 5) – CVS_ID = 11
8,4	2	5	0	Go to Run (Startup)	X				Current State = startup (SM502530 = 6) – CVS_ID = 12
8,4	2	6	0	Go to Run (Defrost)	X				Current State = defrost (SM502530 = 7) – CVS_ID = 13
8,4	2	7	0	Go to Run (Normal)	X				Current State = normal (SM502530 = 8) – CVS_ID = 14
8,4	2	8	0	Go to Shutdown	X				Current State = shutdown (SM502530 = 9) – CVS_ID = 15
8,4	3	0	1	Set Initial Heatup Bed Position	X				
8,4	3	1	0	Return to initial beds states	X				
8,4	4	0	1	Set Bed State	X				
8,4	5	0	1	Set Device State	X				
8,4	6	0	0	Stop Process	X				
9,4				Enable Time Synchronization	X				
9,5				Time Code	X				



9,7		Enable Time Verification	X				Type SubType = 9,9 (SM651530 = 2313) – CVS_ID = 21
14,1		Enable Generation of Packets	X				
14,2		Disable Generation of Packets	X				
14,3		Report Enabled Packets	X				Type SubType = 14,4 (SM652530 = 3588) – CVS_ID = 22
17,1		Perform Connection Report	X				Type SubType = 17,2 (SM653530 = 4354) – CVS_ID = 23

Figure A3-82: General description of commands verifications in the SCE system

- * based on the reception of a $TM(1,1)$ – CVS_ID = 1
- ** based on the reception of a $TM(1,3)$ – CVS_ID = 2
- *** based on the reception of a $TM(1,7)$ – CVS_ID = 3



A5 Lookup Table part

A5.1 General description

A5.1.1 Introduction

This section describes the solution to write and verify the SCE Look Up Table (LUT) for satellite level tests and flight.

The LUT is a set of 301 parameters (175 in the 540 element and 126 in the 530 element) used to tune the SCE on board software. They are stored in the EEPROM and each of them has a size of 32 bits (nevertheless 16 bits is enough for most of them).

The SCE LUT shall be overwritten before most of ground tests to accommodate the SCE activation limitation in the non nominal ground environment (temperature, pressure, gravity). The only available tools for this are the normalized service 6 "Memory management" commands recognized by the SCE. Those are in fact standard tools for investigating, patching and dumping the on board software in case of trouble in flight. Their use for the LUT management does not fit the TM packet management underlying philosophy. This causes their use to face SCOS functionality limitation or constraints.

The main aspect is that, for efficiency and traceability, it is not acceptable to manage the LUT parameters blindly: that is as incomprehensive hexadecimal code blocks. So it has been decided (PLANCK PFM1 progress meeting 2006 October 17th) that the LUT programming and verification shall be done on the basis of comprehensive parameter names and unit values (A, Pa, bar, etc.). Thus dedicated commands and telemetries packet definition with calibrated parameters have been created to manage the LUT.

This solution implies to create a definition for each LUT entry both for command and read-back, and that all those definitions shall be associated with calibrations and limits. As HPSDB allows to define a calibration as the reverse of another one, if all the LUT parameters are calibrated or reading, their calibration for writing are defined as their reverse. Moreover, most of necessary calibrations are already available from the housekeeping parameters definitions.

A5.1.2 Principe of LUT programming

A set of programming command packet have been created to cover all the LUT entries. Those command packets can not address a single LUT entry but a fixed set of parameters. There is no need that the different commands address a similar number of LUT entries.

The entry association however associates parameters that are likely to be updated all at the same time (even to confirm their values). The command will always rewrite all the parameters and all the command parameters will have to be transmitted to the operation for commanding (whatever is already on board).

All the parameters are associated with a calibration that allow the commands parameter fields in the spacecraft command script to be filled by operators with comprehensive values (bar, A, V, etc.). All the parameters are set with no default value and must be filled before to launch a command.



These commands are based on the generic commands service type 6 subtype 2, '*Load Memory Using Absolute Address*'.

A5.1.3 Principe of LUT read back

To enable the read back of LUT values, the most basic solution is to send a command service type 6 subtype 5, '*Memory Dump Using Absolute Address*', and to read the result from a telemetry service type 6 subtype 6, '*Memory Dump Absolute Address*'. But the maximum telemetry (6, 6) packet content is 249 32 bits words (this is 996 octets out of 998 allowable for the data field from the maximum telemetry packet length). Then the LUT cannot be read back with a single packet.

As for the LUT programming, all the parameters are associated with a calibration that allow the operator to see the LUT parameter fields with comprehensive values (bar, A, V, etc.).

So a set of read back telemetry packet definition have been created to cover all the LUT entries, and provide the de-commutation information for the CCS. The set of parameters for telemetries are the same as those for commands LUT programming. To receive these read back telemetries (based on telemetries 6, 6), a set of read back command have been also defined (based on telemetries 6, 5).

The trouble is that the telemetry (6, 6) packet does not contain any header field to associate it with several definition variants. The telemetry (6, 6) can have only one definition. Furthermore, the TM (6, 6) must remain available for other purpose than reading back the LUT (i.e. trouble shooting the SW).

The solution is to enter a single telemetry packet definition, but:

- with overlapping parameter definitions (i.e. several parameter definitions for the same field in the packets),
- and grouping the parameters in "groups" that are coherent with a predefined dump set,
- then, in order to enable the only good definition when using a TC (6, 5) command (memory dump request), to play with the SCC / SCOS functions:
 - Enable/disable TM packet definition,
 - Enable/disable parameter group definition.

Another way of distinction between the different LUT sections for read back has also been added: some validity parameters based on the LUT Memory ID and the LUT start Address parameters values.

A TC packet have been created to send the TC (6, 5) matching each group definition.



A5.1.4 LUT segmentation

The LUT is constituted by 9 different memory pages (the same for LUT programming and for LUT read back):

Mnemonic	Description
SOFTWARE	Parameter for averaging sensors and enabling/disabling of some function
POWERS TIMES	Heater & desorb power and cycle duration
HC REGEN	Health check and regeneration parameters
RUN MODE	Adjustment during run modes (startup, defrost and normal modes)
FAULTS	Fault Conditions and Bad Bed Detection: Automatic diagnostic and FDIR (temperature threshold, pressure, voltage and current)
PID	PID (Proportional Integral Derivative) and Open Loop Algorithms
HEATERS	Parameter for beds resistance value (depend on the SCE model)
CALIBRATIONS 1	Cernox transfer function (depends on the cooler) – first part
CALIBRATIONS 2	Cernox transfer function (depends on the cooler) – second part

Figure A3-83: The SCE LUT segmentation

The two last ones concern the same content but contain too many parameters and must be split in two parts.

A5.1.5 The SC500530 'Get LUT Address' command

The base address of the lookup table to load and use is a parameter that can be changed, within the EEPROM memory. Its value is fixed in the DM EEPROM 8 memory. It is composed of three 32-bits values:

- One at 0x8007ffa
- One at 0x8007ffc
- One at 0x8007ffe

The rule to apply to know the LUT base address is the following:

- If the three values are equal, the lookup table base address is equal to this value
- If two values are equal, the lookup table base address is equal to this value
- If every values are different, the lookup table base address is equal to 0x80000000

This command has the service type 6 and subtype 5 and has the same characteristic of the generic command '*Dump Memory Using Absolute Address*' (CCF fields, PTV, verification ...). It is in fact a command (6, 5) with the three editable parameters that have been fixed and are not editable anyway.

As the base address of the LUT is always in the EEPROM memory, when a choice is given to the operator to enter a memory zone, the '*MEMORY ID*' textual calibration (id=322) is not used as it contains all memory zones. A new textual calibration curve have been created for the choice of the LUT memory zone, with id=323, as defined in Figure A3-84.

Identifier	Description	Values
323	MEMORY ID EEPROM	DM EEPROM 1 / DM EEPROM 2 / DM EEPROM 3 / DM EEPROM 4 / DM EEPROM 5 / DM EEPROM 6 / DM EEPROM 7 / DM EEPROM 8

Figure A3-84: Specific LUT textual calibration



A5.2 LUT programming

As defined in the section A5.1.4, the LUT is constituted by 9 different memory pages.

As already explained in the section A3.4.4, depending on the used equipment, the CUR table allows to choose a calibration curve for telemetry parameters. As there is no equivalent mechanism for commands, distinct commands for the different equipments (FM1, FM2, PFM1 and PFM2) are defined.

So due to LUT parameters which need different numerical calibrations for the 4 different equipments, to enable the LUT programming not only 9 commands are required but 21. They are listed in the Figure A3-85.

CCF_CNAME	CCF_DESCR2	CCF_NPARS
SC501530	TC 6_2 Load LUT Software – FM1, FM2, PFM1 and PFM2	66
SC502559	TC 6_2 Load LUT Powers and Times – FM1, FM2, PFM1 and PFM2	43
SC503559	TC 6_2 Load LUT health Check and Regeneration – FM2	21
SC504559	TC 6_2 Load LUT Run Mode transitions – FM2	30
SC505559	TC 6_2 Load LUT Fault Conditions and Bad Bed Detection – FM2	34
SC506559	TC 6_2 Load LUT PID and Open Loop Algorithms – FM2	17
SC507559	TC 6_2 Load LUT Heaters Resistances – FM1, FM2, PFM1 and PFM2	32
SC508530	TC 6_2 Load LUT Calibrations 1 – FM1, FM2, PFM1 and PFM2	35
SC509530	TC 6_2 Load LUT Calibrations 2 – FM1, FM2, PFM1 and PFM2	41
SC510559	TC 6_2 Load LUT health Check and Regeneration – FM1	21
SC511559	TC 6_2 Load LUT Run Mode transitions – FM1	30
SC512559	TC 6_2 Load LUT Fault Conditions and Bad Bed Detection – FM1	34
SC513559	TC 6_2 Load LUT PID and Open Loop Algorithms – FM1	17
SC514559	TC 6_2 Load LUT health Check and Regeneration – PFM2	21
SC515559	TC 6_2 Load LUT Run Mode transitions – PFM2x	30
SC516559	TC 6_2 Load LUT Fault Conditions and Bad Bed Detection – PFM2	34
SC517559	TC 6_2 Load LUT PID and Open Loop Algorithms – PFM2	17
SC518559	TC 6_2 Load LUT health Check and Regeneration – PFM1	21
SC519559	TC 6_2 Load LUT Run Mode transitions – PFM1	30
SC520559	TC 6_2 Load LUT Fault Conditions and Bad Bed Detection – PFM1	34
SC521559	TC 6_2 Load LUT PID and Open Loop Algorithms – PFM1	17

Figure A3-85: The SCE LUT programming commands

Every LUT programming commands ends by a checksum parameter. As its calculation can not be done automatically by the SCOS 2000 manual stack, to load one of these commands, it is necessary to use the TOPE interface and to have an automatic checksum calculation.

These commands have the service type 6 (CCF_TYPE=6) and subtype 2 (CCF_STYPE=2) and have the same characteristic of the generic command 'Load Memory Using Absolute Address' (CCF fields, PTV, verification ...).

As defined in the section A4.5.5, a command (6, 2) contains four parameters: 'Memory ID', 'Start Address', 'Length' and 'Data Memory + Checksum'. For the three first ones, default values are in the MIB. They are described in the Figure A3-86. The memory ID and the start address are of course editable parameters in case the LUT base address is not the default one. Length is a fixed non editable parameter.



CCF_CNAME	Memory ID	Start Address	Length
SC501530	DM EEPROM 5 (0x8004)	100	48
SC502559		130	38
SC503559		156	16
SC504559		166	25
SC505559		17F	29
SC506559		19C	12
SC507559		1A8	27
SC508530		1C3	30
SC509530		1E1	36
SC510559		156	16
SC511559		166	25
SC512559		17F	29
SC513559		19C	12
SC514559		156	16
SC515559		166	25
SC516559		17F	29
SC517559		19C	12
SC518559		156	16
SC519559		166	25
SC520559		17F	29
SC521559	19C	12	

Figure A3-86: The SCE default values for the LUT programming commands

Remark: the start address is expressed in hexadecimal



A5.3 LUT read back

A5.3.1 LUT read back commands

As defined in the section A5.1.4, the LUT is constituted by 9 different memory pages. So there are nine commands to request a complete dump of the LUT. They are listed in the Figure A3-87.

CCF_CNAME	CCF_DESCR2
SC601530	TC 6_5 Dump LUT Software
SC602559	TC 6_5 Dump LUT Powers and Times
SC603559	TC 6_5 Dump LUT health Check and Regeneration
SC604559	TC 6_5 Dump LUT Run Mode transitions
SC605559	TC 6_5 Dump LUT Fault Conditions and Bad Bed Detection
SC606559	TC 6_5 Dump LUT PID and Open Loop Algorithms
SC607559	TC 6_5 Dump LUT Heaters Resistances
SC608530	TC 6_5 Dump LUT Calibrations 1
SC609530	TC 6_5 Dump LUT Calibrations 1

Figure A3-87: The SCE LUT dump commands

These commands have the service type 6 (CCF_TYPE=6) and subtype 5 (CCF_STYPE=5) and have the same characteristic of the generic command 'Dump Memory Using Absolute Address' (CCF fields, PTV, verification ...).

As defined in the section A4.5.7, a command (6, 5) contains three parameters: 'Memory ID', 'Start Address' and 'Length'. Default values have been set in the MIB. They are the same as for the LUT programming commands (see Figure A3-86). The memory ID and the start address are of course editable parameters in case the LUT base address is not the default one. Length is a fixed non editable parameter.

A5.3.2 LUT read back telemetries

Result of dumps from the previous section can be displayed on the following nine AND:

Name (DPF_NUMBE)	Description (DPF_HEAD)	DPF_TYPE
SA100530	LUT – SOFTWARE	3
SA102559	LUT Powers Times	3
SA103559	LUT HC Regen	1
SA104559	LUT Run Mode	1
SA105559	LUT Faults	3
SA106559	LUT PID	1
SA107559	LUT Heaters	3
SA108530	LUT - CALIBRATIONS 1	3
SA109530	LUT - CALIBRATIONS 2	3

Figure A3-88: The SCE LUT AND

In order to perform enabling/disabling set of parameters, all LUT telemetry parameters have been grouped into parameters group. This facility, not available for the EGSE 2.e3 P5, is implemented with the GRP and GRPA tables.



The GRP table is the group definition file and the GRPA is the group member definition file for parameter groups

Nine parameters groups have been defined; according to the LUT segmentation (see section A5.1.4).



A5.4 LUT segmentation and associated parameters

As previously said the LUT is divided into nine sections. They are all represented by monitoring parameters and command parameters. Their repartition is described in the Figure A3-89.

LUT part	LUT position	Monitoring parameter	Command parameter
Software	0x00 to 0x2f	SM325530 to SM384530	SP101530 to SP168530
Powers and times	0x30 to 0x55	SM201540 to SM238540	SP001540 to SP038540
Health check and regeneration	0x56 to 0x65	SM239540 to SM254540	SP039540 to SP055540 for FM2
Run mode transition	0x66 to 0x7e	SM255540 to SM279540	SP056540 to SP080540 for FM2
Fault conditions and bad bed detection	0x7f to 0x9b	SM280540 to SM308540	SP081540 to SP109540 for FM2
PID	0x9c to 0xa7	SM309540 to SM320540	SP110540 to SP121540 for FM2
Heaters resistances	0xa8 to 0x2	SM321540 to SM347540	SP121540 to SP148540
Calibrations 1	0xc3 to 0xe0	SM385530 to SM414530	SP169530 to SP199530
Calibrations 2	0xe1 to 0x104	SM415530 to SM450530	SP200530 to SP235530

Figure A3-89: Repartition of telemetry and command parameters in the LUT

In Appendix 1 all parameters for each section are described. They are the same for telemetry and for command purpose. In each array are described:

- The possible values, this is the range for command parameters (PRF and PRV tables) and the monitoring limits for telemetry (OCF and OCP tables). There is one definition for each parameter.
- If needed, the associated calibration. It can be a specific LUT calibration or a calibration already defined for telemetry purpose (see Figure A3-90).
- If needed, the unit

One consistency check is to have all parameters ranges within the corresponding numerical curve if it is defined. This is not a problem for parameters associated to calibration curves created only for the LUT purpose, because in this specific case, the ranges of the calibration curves are set to the ranges of the corresponding parameters. But for calibration curves which are already defined for telemetry purpose, it ranges are fixed by the manufacturer, so in this case it is important to assume that the LUT parameters ranges are within the corresponding calibration curves. To enable this check, the Figure A3-90 lists all calibration curves defined for the telemetry purpose, for some sensors, used for the LUT purpose, and the corresponding ranges, which can be dependant of the used equipment (for more detail, see section A3.3.1.3).



Parameter name	Minimum value	Maximum value
P1	0.29	68.95
P7	0.49	69.27
P8	0.01	3.45
T5	6.9	27
T6	15.8	39
T7	10.1	156
T15	219.34	375.2
T17	239.35	396.01
T18	239.16	395.7
T30	15.4	190
Temperature Electronics	248.74	358.74
Intensity H21-H26	0	1.855

Figure A3-90: Calibration curves defined for telemetry purpose used for the LUT purpose

For LUT section description and values see Appendix 1