



|                               |   |
|-------------------------------|---|
| <b>Publication Year</b>       | 2022  |
| <b>Acceptance in OA @INAF</b> | 2024-02-19T09:52:24Z  |
| <b>Title</b>                  | Architecture of C-band Phased Array Feed with RFSoc digital beamformer                          |
| <b>Authors</b>                | NAVARRINI, Alessandro; MELIS, Andrea; COMORETTO, Giovanni; PISANU, Tonino; NESTI, Renzo; et al. |
| <b>DOI</b>                    | 10.23919/AT-AP-RASC54737.2022.9814401   |
| <b>Handle</b>                 | <a href="http://hdl.handle.net/20.500.12386/34769">http://hdl.handle.net/20.500.12386/34769</a> |



## Architecture of C-band Phased Array Feed with RFSoc digital beamformer

A. Navarrini<sup>(1)</sup>, A. Melis<sup>(1)</sup>, G. Comoretto<sup>(2)</sup>, T. Pisanu<sup>(1)</sup>, R. Nesti<sup>(2)</sup>, P. Marongiu<sup>(1)</sup>, P. Ortu<sup>(1)</sup>, P. Maxia<sup>(1)</sup>, A. Ladu<sup>(1)</sup>, H. Ghobadi<sup>(2)</sup>, R. Concu<sup>(1)</sup>, G. Angius<sup>(1)</sup>, A. Cabras<sup>(1)</sup>, L. Schirru<sup>(1)</sup>, P. Di Ninni<sup>(2)</sup>, M. Belluso<sup>(3)</sup>, S. Billotta<sup>(3)</sup>

(1) INAF (National Institute for Astrophysics)-Astronomical Observatory of Cagliari, Selargius, Italy

(2) INAF (National Institute for Astrophysics)-Arcetri Astrophysical Observatory, Florence, Italy

(3) INAF (National Institute for Astrophysics)-Catania Astronomical Observatory, Catania, Italy

### Abstract

We describe the architecture of a room-temperature C-band Phased Array Feed (PAF) demonstrator based on Radio Frequency System-on-Chip (RFSoc) for radio astronomy application. The instrument operates across the 4.75-6.00 GHz RF band (C-band). The RF section includes a compact module based on an 8×8 array of dual-polarization antennas integrated with MMIC (Monolithic Microwave Integrated Circuit) Low Noise Amplifiers (LNAs). A subset of 32 elements of one of the two polarization channels of the 128 antennas are connected to the LNAs, while the rest are terminated into internal loads. Following two stages of filtering and signal conditioning, the 32 RF signals are injected in two commercial RFSoc digital boards, each accepting 16 inputs with 1.25 GHz bandwidth, that will perform the frequency channelization, the partial and final beamforming of four independent beams with 1.25 GHz instantaneous bandwidth.

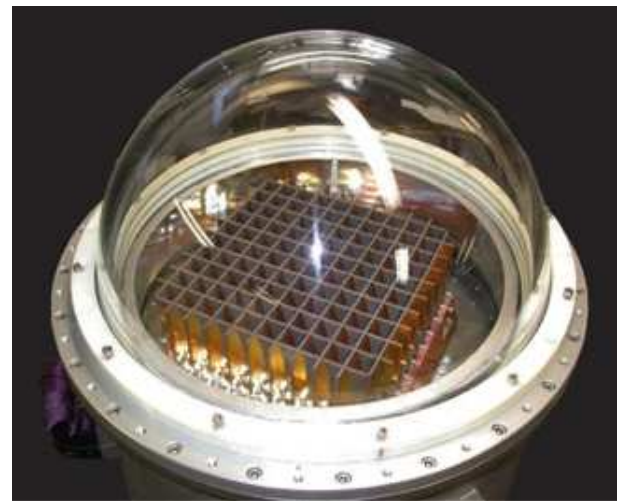
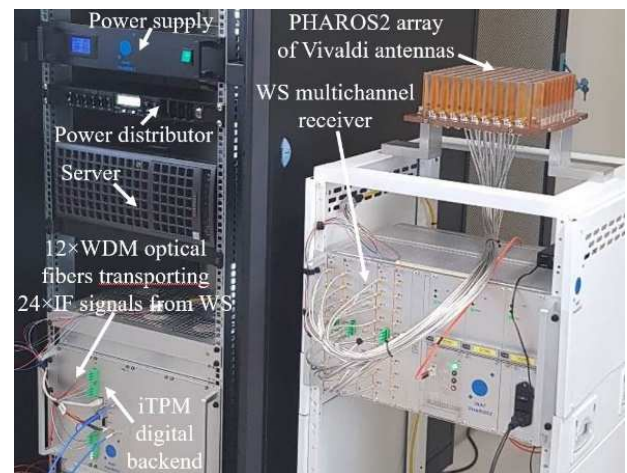

**Figure 1.** C-band PHAROS array showing the 10×11 dual polarization Vivaldi antennas through half-dome Plexiglas vacuum window.

### 1. Introduction

High-sensitivity large-scale surveys are an essential tool for new discoveries in radio astronomy. A PAF placed at the focal plane of an antenna can increase the Field-of-View (FoV) and the mapping efficiency by fully sampling the sky [1]-[2]-[3]. A PAF consists of closely packed antenna elements with about half wavelength element separation that, by spatially sampling the focal plane, can synthesize multiple independent beams and be set to Nyquist-sample the sky. Multiple beams are formed by electronically adding the signals from different groups of radiating elements of the array. An antenna element can contribute to form multiple beams. The properties of the beams can be optimized over a wide range of frequencies by electronically controlling each element phase and amplitude (complex weights) leading to high aperture efficiency and low spillover.

We are building on our successful experience with the development of the PHAROS (PHased Arrays for Reflector Observing Systems) cryogenically cooled C-band PAF demonstrator with analogue beamformer [4]-[5] (Fig. 1) and on its upgrade, PHAROS2 [6]-[7], utilizing a Warm Section (WS) multi-element downconverter [8]



**Figure 2.** PHAROS2 hardware used for analog signal treatment (C-band array of Vivaldi antennas, Warm Section multichannel receiver and pre-Analogue to Digital Unit) and digital beamforming by the iTPM backend, based on Field Programmable Gate Arrays (FPGAs).

and a 275 MHz bandwidth digital beamformer [9]-[10] based on the iTPM Italian Tile Processing Module [11] (Fig. 2), to design a new PAF demonstrator with digital beamformer capable of delivering an instantaneous

bandwidth of 1.25 GHz. The design takes advantage of the performance of the Xilinx Zynq UltraScale+ RFSoc technology, which currently allows signal digitization and processing with maximum input frequency up to 6 GHz. Unlike PHAROS2, which adopts a Warm Section, the new PAF architecture allows direct sampling of the RF signals, thus eliminating the need of a downconversion stage, with great benefits in terms of engineering complexity, mechanical compactness and costs.

We describe our plans and the architecture for the new C-band PAF demonstrator we are designing for 4.75-6.00 GHz. The instrument will be placed at the focal plane of a large radio telescope. The prototype instrument will be based on RFSoc and will deliver four independent digitally formed beams with 1.25 GHz bandwidth. The PAF architecture is scalable in terms of number of array elements, number of beams and instantaneous bandwidth. The demonstrator will operate at room temperature. However, the design will consider aspects related to cryogenic operation, in view of designing a broadband 3.0-7.7 GHz low-noise PAF with >30 beams per polarization and >1 GHz bandwidth for the 64 m diameter Sardinia Radio Telescope [12], as required to perform high-sensitivity large scale radio astronomy surveys [13]-[14]. The PAF will also be employed for space debris studies [15]. The adopted technologies could find application in the Square Kilometer Array project [16].

## 2. Architecture of the C-band PAF with RFSoc

Figures 3 and 4 show a simplified schematic of the array and the full architecture of the PAF, respectively. The PAF architecture adopts 32 identical RF signal chains, each of which is composed of an antenna integrated with a MMIC LNA and with a 4.75-6.00 GHz filter cascaded with an analog signal conditioning module. The signals are injected in two Xilinx ZCU216 RFSoc boards for digitization and beamforming. The two digital boards communicate through a network switch. Data are stored in a PC.

## 3. PAF digital signal processing with RFSoc

Each Xilinx ZCU216 RFSoc (Fig. 5) is capable of acquiring and processing up to  $\approx 1.25$  GHz bandwidth RF streams from 16 single-polarization antennas, using a 2.5 GS/sec sampling rate. Each sample is coded with 14 bits.

Therefore, each board manages 560 Gbps and process the signals to accommodate its maximum I/O throughput of 100 Gbps, available through 4 x 25 Gbps Ethernet interfaces (QSFP). Data processing will include channelization of the sampled data for each antenna based on an oversampling polyphaser filterbank architecture and beamforming. Each ZCU216 produces four beams that are added in one of the two boards (for example #1 of Fig. 2). The four complete beams are formed and retrieved from the second ZCU216 (#2 of Fig. 2). The 100 Gbps switch is not needed if only the integrated beams are of interest.

The digital processing architecture is similar to the one of PHAROS2, described in [9].

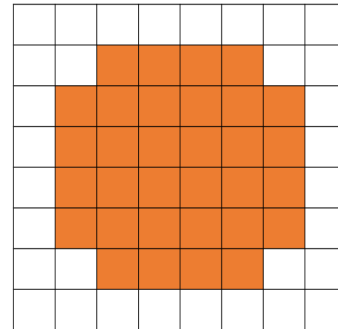

**Figure 3.** Simplified schematic of the 8×8 array of antennas to be placed at the focal plane of a large radio telescope. Each element will be sensitive to two orthogonal linear polarization signals. The inner 32 antenna elements (in orange) are active, i.e. cascaded with MMIC LNAs. The outer elements (in white) are dummy.

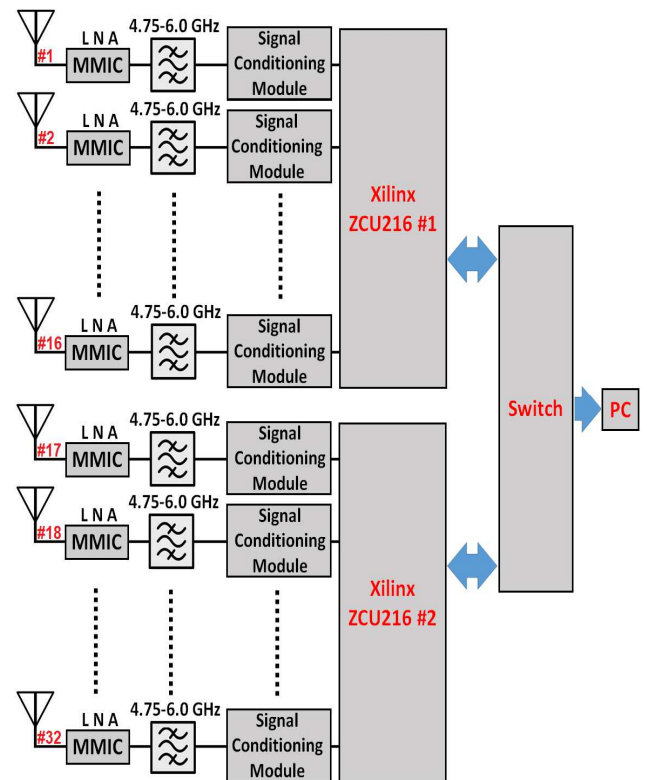

**Figure 4.** Block diagram of the 4.75-6.00 GHz PAF showing the 32 RF signal chains and the two digital RFSoc boards connected to a 100 Gbps network switch and a PC.

## 4. Conclusions

We described the architecture of a C-band PAF demonstrator with digital beamformer based on RFSoc. The demonstrator will be capable of forming four independent RF beams over an instantaneous bandwidth of 1.25 GHz.



**Figure 5.** Picture of one Xilinx ZCU216 RFSoc evaluation kit. A mezzanine board, shown on the lower right side, will be used to connect the ZCU216 with the RF module (outputs of the signal conditioning modules).

## 5. Acknowledgements

This project received funds from INAF Scientific Directorate “Funzione Obiettivo 1.05.03.32.02 “Fondo pluriennale SKA CTA 2019”.

## References

- [1] J.R. Fisher, R.F. Bradely, “Full-sampling array feeds for radio telescopes,” *Proceedings of SPIE Astronomical Telescopes and Instrumentation*, Vol. 4015, 2000.
- [2] K. Warnick, R. Maaskant, M.V. Ivashina, D.B. Davidson, B.D. Jeffs, “High-Sensitivity Phased Array Receivers for Radio Astronomy, *Proceedings of the IEEE*, Vol. 104, Issue 3, pp. 607-622, March 2016.
- [3] D. Anish Roshi et al., “Performance of a highly sensitive, 19-element, dual-polarization, cryogenic L-band phased array feed on the Green Bank Telescope,” *The Astronomical Journal*, 155:202, May 2018.
- [4] W. Ciccognani et al “A GaAs Front-end Receiver for Radio Astronomy Applications,” *13th IEEE Melecon 2006*, May 16-19, Spain.
- [5] L. Liu et al. “Analysis of Vivaldi array antenna for phased array feeds application,” *IEEE MTT-S Int. Conf. on Num. Elec. and Multiph. Mod. and Opt. for RF, Micr., and THz App. (NEMO)*, Seville, Spain, 17-19 May, 2017.
- [6] A. Navarrini et al, “Design of PHAROS2 Phased Array Feed,” *Proc. of 2nd URSI Atl. Radio Sci. Meet. (AT-RASC)*, Gran Canaria, Spain, 28 May – 1 June 2018.
- [7] A. Navarrini et al. "The Warm Receiver Section and the Digital Backend of the PHAROS2 Phased Array Feed," *IEEE Int. Symposium on Phased Array Systems and Technology*, Waltham, MA, USA, Oct. 15-18, 2019.
- [8] A. Navarrini et al. “The Room Temperature Multi-Channel Heterodyne Receiver Section of the PHAROS2 Phased Array Feed” *MDPI Electronics*, Vol. 8, Issue 6, 666, June 2019.
- [9] A. Melis et al., “A Digital Beamformer for the PHAROS2 Phased Array Feed, *Journal of Astronomical Instrumentation*,” Vol. 09, No. 03, 2050013, October 2020.
- [10] G. Pupillo et al., “Preliminary characterization of the digitally formed beams of PHAROS2 Phased Array Feed,” *Proc. of European Microwave Week 2020*, Utrecht, The Netherlands, 10-15 Jan. 2021.
- [11] G. Naldi et al. “Development of a new digital signal processing platform for the Square Kilometer Array.” *Proc. of 2nd URSI Atl. Radio Sci. Meet. (AT-RASC)*, Gran Canaria, Spain, 28 May – 1 June 2018.
- [12] I. Prandoni et al. “The Sardinia Radio Telescope: From a Technological Project to a Radio Observatory,” *A&A*, vol. 608, no. A40, Dec. 2017, DOI: 10.1051/0004-6361/201630243.
- [13] A. Navarrini et al., “Electromagnetic simulation and beam-pattern optimization of a C-band Phased Array Feed for SRT,” *IEEE UKRON2019 Conference*, Lviv, Ukraine, July 2-6, 2019, pp. 137-143, DOI: 10.1109/UKRCON.2019.8879888.
- [14] A. Navarrini et al. “Front-Ends and Phased Array Feeds for the Sardinia Radio Telescope,” *Proceedings of 32nd URSI GASS Conference*, Montreal, 19-26 August 2017.
- [15] L. Schirru et al. "Advantages of using a C-band Phased Array Feed as a receiver in the Sardinia Radio Telescope for Space Debris monitoring, *IEEE UKRON2019 Conference*, Lviv, Ukraine, July 2-6, 2019, pp. 133-136, DOI: 10.1109/UKRCON.2019.8879919.
- [16] A. van Ardenne et al., “Extending the Field of View with Phased Array Techniques: Results of European SKA Research.” *Proc. IEEE* 2009, 97, 1531–1542.