



Publication Year	2016
Acceptance in OA	2020-05-12T16:59:06Z
Title	SHARK-NIR: from K-band to a key instrument, a status update
Authors	FARINATO, JACOPO, BACCIOTTI, Francesca, BAFFA, Carlo, BARUFFOLO, Andrea, BERGOMI, Maria, BONGIORNO, ANGELA, CARBONARO, LUCA, CAROLO, ELENA, Carlotti, Alexis, CENTRONE, Mauro, Close, Laird, DE PASCALE, Marco, DIMA, MARCO, D'ORAZI, VALENTINA, ESPOSITO, Simone, FANTINEL, Daniela, FARISATO, Giancarlo, Gaessler, Wolfgang, GIALLONGO, Emanuele, GREGGIO, DAVIDE, Guyon, Olivier, Hinz, Philip, Lisi, Franco, MAGRIN, DEMETRIO, MARAFATTO, Luca, Mohr, Lars, Montoya, Manny, PEDICHINI, Fernando, PINNA, Enrico, PUGLISI, Alfio Timothy, RAGAZZONI, Roberto, SALASNICH, Bernardo, STANGALINI, MARCO, Vassallo, Daniele, Verinaud, Christophe, VIOTTO, VALENTINA
Publisher's version (DOI)	10.1117/12.2233545
Handle	http://hdl.handle.net/20.500.12386/24758
Serie	PROCEEDINGS OF SPIE
Volume	9909

SHARK-NIR: from K-band to a key instrument, a status update

Jacopo Farinato^{*a,h}, Francesca Bacciotti^b, Carlo Baffa^b, Andrea Baruffolo^a, Maria Bergomi^{a,h},
Angela Bongiorno^c, Luca Carbonaro^{b,h}, Elena Carolo^{a,h}, Alexis Carlotti^d, Mauro Centrone^{c,h},
Laird Close^e, Marco De Pascale^a, Marco Dima^{a,h}, Valentina D'Orazi^a, Simone Esposito^{b,h},
Daniela Fantinel^a, Giancarlo Farisato^a, Wolfgang Gaessler^f, Emanuele Giallongo^{c,h},
Davide Greggio^{a,g,h}, Olivier Guyon^e, Philip Hinz^e, Franco Lisi^b, Demetrio Magrin^{a,h},
Luca Marafatto^{a,h}, Lars Mohr^f, Manny Montoya^c, Fernando Pedichini^{c,h}, Enrico Pinna^{b,h},
Alfio Puglisi^{b,h}, Roberto Ragazzoni^{a,h}, Bernardo Salasnich^a, Marco Stangalini^{c,h},
Daniele Vassallo^{a,g,h}, Christophe Verinaud^d, Valentina Viotto^{a,h}

^aINAF – Osservatorio Astronomico di Padova, Vicolo dell'Osservatorio 5, 35122, Padova, Italy;

^bINAF – Osservatorio Astrofisico di Arcetri, Largo Enrico Fermi, 5, 50125 Firenze, Italy;

^cINAF – Osservatorio Astronomico di Roma, Via Frascati 33, 00078, Monte Porzio Catone (Roma), Italy;

^dInstitut de Planétologie et d'Astrophysique de Grenoble, 414, Rue de la Piscine, Domaine Universitaire, 38400 St-Martin d'Hères, France;

^eDepartment of Astronomy/Steward Observatory, 933 North Cherry Avenue, Tucson, AZ 85721-0065 (USA)

^fMax-Planck-Institut für Astronomie, Königstuhl 17 D-69117 Heidelberg, Germany

^gDipartimento di Fisica e Astronomia, Università degli Studi di Padova, Vicolo dell'Osservatorio 3, 35122, Padova, Italy;

^hADONI - Laboratorio Nazionale Ottiche Adattive - National Laboratory for Adaptive Optics – Italy

*jacopo.farinato@oapd.inaf.it

ABSTRACT

SHARK-NIR channel is one of the two coronagraphic instruments proposed for the Large Binocular Telescope, in the framework of the call for second generation instruments, issued in 2014. Together with the SHARK-VIS channel, it will offer a few observing modes (direct imaging, coronagraphic imaging and coronagraphic low resolution spectroscopy) covering a wide wavelength domain, going from 0.5 μ m to 1.7 μ m.

Initially proposed as an instrument covering also the K-band, the current design foresees a camera working from Y to H bands, exploiting in this way the synergy with other LBT instruments such as LBTI, which is actually covering wavelengths greater than L' band, and it will be soon upgraded to work also in K band.

SHARK-NIR has been undergoing the conceptual design review at the end of 2015 and it has been approved to proceed to the final design phase, receiving the green light for successive construction and installation at LBT.

The current design is significantly more flexible than the previous one, having an additional intermediate pupil plane that will allow the usage of coronagraphic techniques very efficient in term of contrast and vicinity to the star, increasing the instrument coronagraphic performance.

The latter is necessary to properly exploit the search of giant exo-planets, which is the main science case and the driver for the technical choices of SHARK-NIR. We also emphasize that the LBT AO SOUL upgrade will further improve the AO performance, making possible to extend the exo-planet search to target fainter than normally achieved by other 8-m class telescopes, and opening in this way to other very interesting scientific scenarios, such as the characterization of AGN and Quasars (normally too faint to be observed) and increasing considerably the sample of disks and jets to be studied.

Finally, we emphasize that SHARK-NIR will offer XAO direct imaging capability on a FoV of about 15"x15", and a simple coronagraphic spectroscopic mode offering spectral resolution ranging from few hundreds to few thousands.

This article presents the current instrument design, together with the milestones for its installation at LBT.

Keywords: Coronagraphy, eXtreme Adaptive Optics, Large Binocular Telescope

1. INTRODUCTION

SHARK (System for coronagraphy with High order Adaptive optics from R to K band)^[1] is an instrument proposed for the LBT^[2] in the framework of the "2014 Call for Proposals for Instrument Upgrades and New Instruments". It is composed by two channels, covering different and partially overlapping wavelength ranges: SHARK-VIS^[3] will work from 0.5 μ m to 1 μ m, while SHARK-NIR^[4] is dedicated to near infrared bands, Y, J and H, operating from 0.96 μ m to 1.7 μ m. Both channels recently successfully passed the Conceptual Design Review (CDP), and have been approved to undergo the Final Design Phase (FDP), to be later installed one for each LBT arm. SHARK will exploit, in its binocular fashion, unique challenging science ranging from exoplanet search and characterization to star forming regions with simultaneous spectral coverage from R to H band, taking advantage of the excellent performances of the LBT AO^[5] systems, based on the Pyramid Wave Front Sensor^[6] (PWFS) and on the Adaptive Secondary Mirrors^[7].

The spectral coverage will become even larger when used in combination with LMIRcam of LBTI^[8], which will be upgraded soon to work in K band, and will thus offer coronagraphic direct imaging from K to M band. In this scenario, LBT will have the possibility to make contemporary coronagraphic observations with three instruments:

- SHARK-NIR on one arm, operating between Y and H bands
- SHARK-VIS and LMIRcam on the other arm, that will operate contemporary (through a dedicated dichroic splitting the visible from the infrared light), the first in V,R I and Z bands, the second in K, L and M bands

which is a unique scenario for coronagraphy in the framework of the modern planet finders. Another unique characteristic of LBT is that, with the foreseen upgrade of the AO system (SOUL, see [9]), the performance of the AO will be pushed in two different directions:

- in the eXtreme Adaptive Optics (XAO) regime, by upgrading the ASM speed to 2KHz and improving the controller in order to increase the number of possible corrected modes from the current 400 to about 600
- in the faint end regime, by gaining between 1 and 2 magnitude using a new detector with nearly 0 Read out Noise (RoN), increasing a lot the sample of possible exo-planetary systems to be exploited, and allowing to make also extra-galactic science by characterizing for example the morphology of faint targets such as AGN and QUASARS.

This paper describes the SHARK-NIR instrument, which has been presented at the CDR with a design different from the one proposed in the "LBT call for instrumentation"^[1], devised in order to exploit as much as possible the synergy both with the LBT currently available instruments and with the accepted instruments upgrades which will be available in the next future, as it will be better described in the next section.

2. SHARK-NIR DESIGN CHOICES

Initially proposed as an instrument covering also the K-band and characterized by a FoV of about 30"x30", the current design foresees a camera working from Y to H bands and a smaller FoV (of the order of 15"x15").

In fact, the LBT instrument scenario changed with respect to 2014, when the initial proposal was submitted. First of all, LUCI had successful first light, and we recall that it is a camera for direct imaging operating in J, H and K band, characterized by a FoV of about 30"x30". Additionally, LBT approved an upgrade of LMIRCam, the NIR camera of LBTI, which is actually covering wavelengths greater than L' band, but it will be soon upgraded to work also in K band, with a FoV of the order of 15"x15". Furthermore, all the partners have been pushing on the project schedule, above all for the exo-planet science case, emphasizing that a fast track project is mandatory to produce outstanding science. It has to be noted that the old design, working from J to K band, would obviously have implied the use of a cryostat, to maintain the full optical train of the instrument at a low temperature, in order to minimize the thermal background. This

necessity would translate into further needs. First of all, the whole optical design was required to be as compact as possible, and this did not allow to implement several coronagraphic techniques with different requirements (e.g. the presence of an intermediate pupil plane). Moreover, to minimize the stress between the various opto-mechanical components, when going from ambient to operating temperature, the fully reflective design was foreseen to be implemented using aluminum optics, in order to keep the same CTE of the mechanics. On the other hand, aluminum optics, despite being light and suitable for cryogenic systems, can be machined only up to a certain level of micro-roughness, limiting the nominal performance of the full optical train.

For all these reasons, the current design consist on a camera operating from Y to H bands on a smaller FoV (of the order of 15"x15"), and the noticeable simplification also means a faster instrument development.

This solution properly exploits the synergy with the other LBT instruments:

- for relatively wide field (30") direct imaging, LUCI will address the science, with top Strehl performance of the order of 75% in the center (may be even better, being this a preliminary result)
- for the few targets which needs extreme Strehl to be explored (top performance of the order of 90%, driven by the AO performance) in a smaller field (of the order of 15-20"), SHAR(K)-NIR will do the job in H band and LMIRcam (after the upgrade) in K band
- SHAR(K)-NIR will be more efficient in the coronagraphic science and, depending on the science case, will complement the observations either with LMIRcam used in coronagraphic fashion in L' band (exo-planet case) or with LMIRcam used in coronagraphic way in K band (AGN/QSO and Jets/Disks case)

3. THE SCIENTIFIC CASE

The direct detection of extra solar planets is one of the most exciting goals, as already mentioned in the previous sections. Indeed, the resolution achievable with a 10-m class telescope allows to access, in the NIR domain, gaseous giant planets of Jupiter size or bigger, and still it is a very challenging task to be achieved, due to the very high contrast and vicinity to the hosting star required. There are several scientific goals to be possibly exploited in the exo-planet science case, ranging from the direct detection of unknown giant planets, to the follow up of known planets (through spectroscopic and photometric characterization), which requires of course the implementation of a spectroscopic mode with modest spectral resolution, which is currently foreseen in SHARK-NIR through a long slit positioned into the intermediate focal plane.

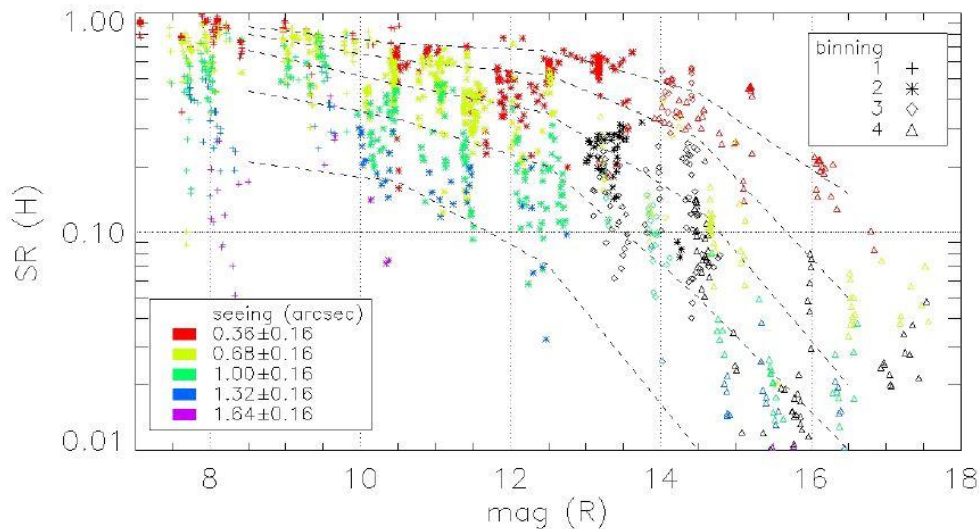

Figure 1: a summary of the FLAO performance obtained in H band with different observing conditions

The science to be exploited with SHARK-NIR is definitely not only limited to the exo-planet case. The study of proto-planetary disks is fundamental to comprehend the formation of our own solar system as well as of extra-solar planetary

systems. To understand how matter aggregates to form the building blocks of planetary bodies, there is the need to investigate not only the evolution of the disk itself, but also the role of jets in shaping its structure. This requires observing the system at high angular resolution as close as possible to the parent star, occulting its light to enhance the area where the interplay between the accretion and ejection of matter dominates the dynamics.

Other very interesting and challenging topics can be found in the extragalactic science, where the capabilities of SHARK-NIR in terms of spatial resolution and contrast enhancement may be applied to study the AGN-host relations as well as Dumped Ly- α systems (DLAs), to constrain the Black Hole feeding mechanism and to trace, in bright quasars, molecular outflows powerful enough to clean the inner kilo-parsec and quench the star formation.

There is anyhow an important feature of the LBT AO which, exploited in the proper way, may give to SHARK-NIR the possibility to explore unique coronagraphic science. The Pyramid WFS has a demonstrated gain in sensitivity compared to other WFS commonly used, such as SH (see [10], [11], [12], [13] and [14]). This fact gives to the LBT AO systems the capability of achieving high Strehl Ratio (of the order of 70%) at moderately faint magnitude (R~12 or even occasionally fainter, depending on the observing conditions), as it is shown in the impressive collection of FLAO results reported in Figure 1.

This excellent performance will be further enhanced with the implementation of the AO upgrade SOUL, as it is shown in Figure 2 where, depending on the CCD choice, the capability of achieving Strehl as high as 70% can be pushed to star as faint as magnitude 13.5, and it has to be emphasized that these curves have been computed not in excellent seeing conditions (0.8").

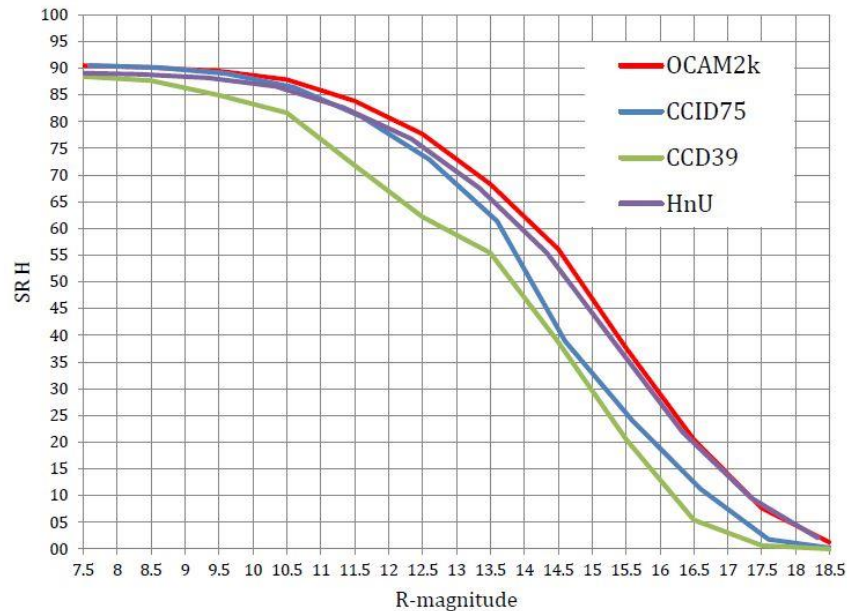

Figure 2: the SOUL improvement in the LBT AO performance (the current is in green line) with different CCD choices, computed with a seeing of 0.8". The baseline for SOUL is the OCAM2K camera.

This performance will open the field of high-contrast AO coronagraphic imaging to stars much fainter than feasible using other coronagraphic instruments, allowing deep search for planets around targets like, e.g., M dwarfs in nearby young associations and solar type stars in nearby star-forming regions (Taurus-Auriga at 140 pc). Also in the extragalactic field, the sample of AGN and, above all, of Quasars to be explored will go from a few tenths to a few hundreds, changing the perspective of the science to be achieved.

This is definitely the characteristic which may give to SHARK-NIR unique opportunities in the coronagraphic instrument scenario.

4. SHARK-NIR INSTRUMENT DESCRIPTION

The basic idea of SHARK-NIR is a camera for direct imaging coronagraphy and spectroscopy, using the corrected wavefront provided by the LBT ASM, operated through one of the existing AO WFS.

A very suitable position for the installation of SHARK-NIR is at the entrance of LBTI (see Figure 3), very close to the WFS that is dedicated to LBTI itself, which should be used to sense and drive the ASM, providing the corrected wavefront to SHARK-NIR. A dichroic, deployable in front of the entrance window of LBTI, shall pick-up and re-direct the wavelength range between 0.96 and 1.7 microns toward SHARK-NIR, letting the VIS light to go to the WFS.

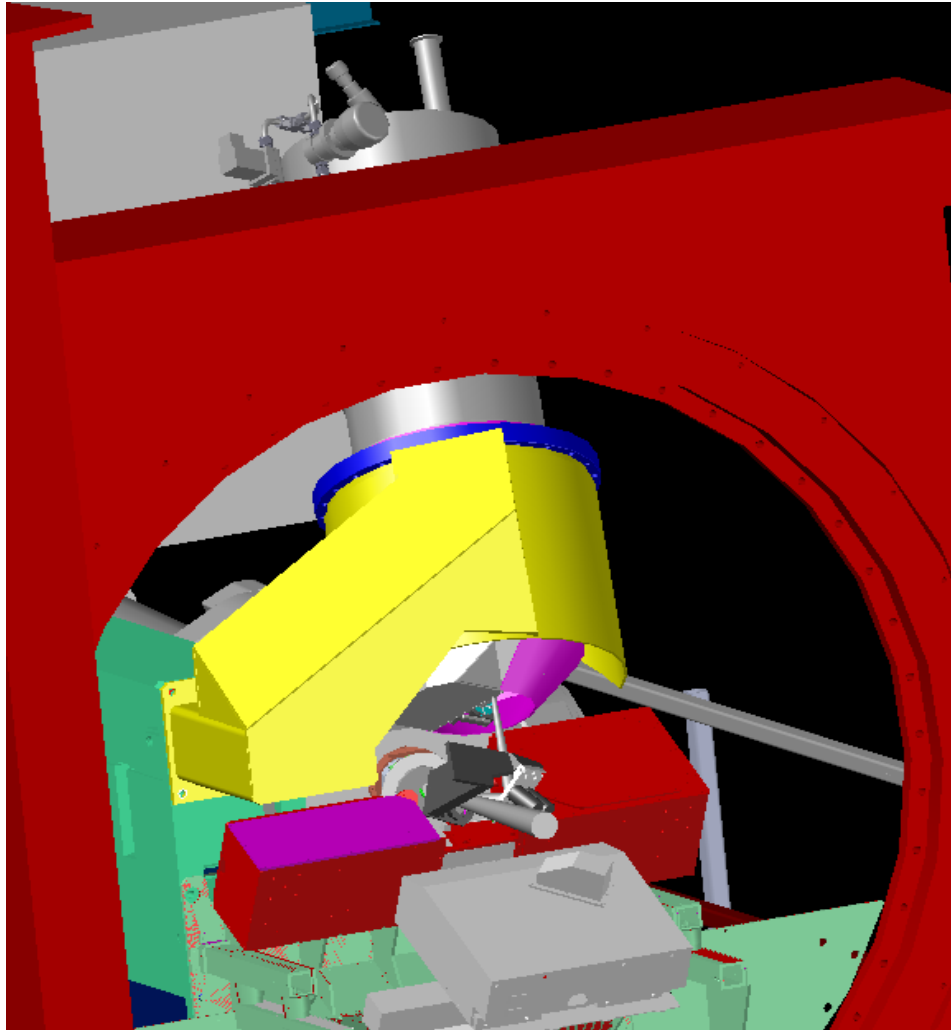

Figure 3: the SHARK-NIR instrument positioned at the entrance of LBTI

Being SHARK-NIR also a coronagraphic instrument, the camera has to be designed to accomplish an extreme performance, ideally not to decrease the correction provided by the AO system. In fact, all the coronagraphic techniques that may be implemented need a SR as high as possible to provide very good contrast. This requires optics machined to a state of the art technology and polished to nanometric level of roughness, properly aligned and installed on very robust mounts. The whole instrument mechanics has to be very stiff and designed to minimize the effect of the flexures.

Additionally, to maintain the performance as good as possible at every observing altitude, it is necessary to implement an ADC to compensate for the atmospheric dispersion.

Some of the foreseen science cases need to perform the field de-rotation, to accomplish which the whole instrument has to be mounted on a mechanical bearing.

A NIR camera, based on an HAWAII II detector, cooled at about 80°K to minimize the thermal background, will provide a FoV of the order of 15"×15", with a plate scale foreseeing two pixels on the diffraction limit PSF at 0.96μm.

A few subsystems have been introduced in the instrument design with the purpose of optimizing the instrument performance.

For the NCPA minimization, a local DM has been introduced into the first pupil plane, allowing a local removal of the aberrations. The same DM, used in T-T fashion, may be used to correct undesired PSF movements during a scientific exposure. The latter correction requires a dedicated T-T sensor, which has been placed after the first pupil plane, into the collimated beam (a beam splitter will pick-up few percent of the light to be sent to the sensor).

The new non-cryogenic design of SHARK-NIR allows creating an additional intermediate pupil plane, permitting to consider coronagraphic techniques which require apodizing masks, such as the Apodized Pupil Lyot Coronagraph (APLC), which has been implemented both in SPHERE^[15], GPI^[16] and SCExAO^[17]. Between the DM and the beam splitter feeding the T-T sensor, a filter wheel positioned at 50mm from the pupil plane carries the apodizing masks. These kinds of masks are normally placed exactly into the pupil plane, which is occupied by the DM in our design. We have carefully evaluated the impact of having the masks slightly displaced with respect to the pupil plane, and it turned out that the effect is basically negligible if the masks are designed to take this fact into account.

As we mentioned at the beginning of this section, SHARK-NIR has essentially three observing modes, described in the following sections.

4.1 Direct Imaging Mode

In this observing mode, SHARK will provide an unobstructed FoV of 15.3"×15.3", with a correction which is nominally nearly perfect over the full 15.3" diameter (SR>99.5% at 1μm). Even considering very relaxed tolerances for the alignment of the optical elements (±200μm for the off-axis parabola decenter, ±3' for their tilt), the final performance is very good (SR>97.5% at 1μm over the full 15.3" diameter).

Even with the ADC inserted (which is deployable, to have the best possible optical quality when observing at small zenithal angles), the optical performance remains very good, ensuring for example an on-axis SR >98%, while at the detector corner (at the edge of the field diagonal) it decreases to ~94%, for a zenithal distance of 50°.

The total throughput of the instrument without the ADC into the field is about 62%, while inserting the ADC it is about 58%.

The Field rotation can be compensated through the mechanical bearing, which will accomplish a tracking precision of about $(\lambda/D)/20$ at 1μm and perform a maximum rotation of 190°.

The scientific filters available for the direct imaging mode are 14, distributed in the two filter wheels positioned in the collimated beam after the 2nd pupil plane.

4.2 Coronagraphic Mode

The current design of SHARK-NIR foresees two intermediate pupil and focal planes, with the purpose of implementing a large variety of coronagraphic techniques, including the ones that require the pupil apodization, such as the APPLC or the Shaped Pupil (SP). We have carefully evaluated which techniques may be worth of being implemented, considering both the characteristics of the most diffused coronagraph and considering the LBT AO situation, and we have selected 4 techniques to be considered and analyzed through a simulation code that we have developed. The four techniques considered are:

- Lyot, which requires an occulting mask into the 1st focal plane and a pupil stop on the 2nd pupil plane
- Gaussian Lyot, which requires a gaussian stop into the 1st focal plane and a pupil stop on the 2nd pupil plane
- Shaped Pupil, which requires an apodizing mask into the 1st pupil plane and an occulting mask into the 1st focal plane
- APPLC, which requires an apodizing mask into the 1st pupil plane, an occulting mask into the 1st focal plane and a pupil stop into the 2nd pupil plane

All these techniques have the purpose to dim (ideally cancel) the light of the central star, in a way to enhance the contrast in the vicinity of the star itself, allowing to detect much fainter companions (exo-planets case for example) or to explore the morphology of the object under study (Jets/Disks case and AGN/QSO case). They are characterized by different operating distances from the central star (IWA), and by different contrast that can be reached at a certain distance, by different throughput and by different FoVs.

Ideally, we would like to implement a few techniques in a way to fulfill as much as possible the different needs of the different science cases (in term of contrast and IWA), and to provide a useful tool to select the proper technique for each kind of scientific target.

This observing mode will provide the possibility to observe both using the field derotation (through a bearing) and to observe in ADI mode. The ADI mode foresees to let the field rotate, during the observation, to distinguish the planet (which will rotate with the field) with respect to the Quasi Static Speckles, supposing that the latter will move of a very small amount during the observing time. To exploit the science cases which need the field derotation, it will be possible to use only center-symmetric masks (such as the ones of classical Lyot and Gaussian Lyot), since otherwise the apodizing masks (which are normally design to take into account also the secondary spiders) would also have to be rotated, adding a considerable complexity to the instrument.

The coronagraphic FoV, as already mentioned, will depend on the coronagraphic techniques selected, and will range from about $12\lambda/D$ for the Shaped Pupil, to the full camera FoV of $15.3'' \times 15.3''$ for the Lyot cases. The IWA is also depending on the technique, and will go from $2\lambda/D$ (SP and APLC) to $4-5 \lambda/D$ (Lyot and Gaussian Lyot).

The total throughput of the instrument depends upon the coronagraphic technique and the presence of the ADC, and is of the order of 50% with the standard Lyot technique, decreasing to ~18% with the SP coronagraph.

The optical quality of the FoV is greater than 99% and also in this case, the ADC may be inserted into the beam to compensate for the atmospheric dispersion.

In this observing mode, 14 scientific filters can be selected for the observations.

4.3 Spectroscopic Mode

A long-slit spectroscopic (LSS) coronagraphic mode will be implemented in SHARK, with two different resolutions: a low-resolution mode ($R \sim 100$), in order to target faint targets, and a medium-resolution mode ($R \sim 1500$) to get spectral information of the faint objects around the bright targets.

In fact, in the focal plane wheel (the ones carrying the occulting masks defining the coronagraphic IWA), a few positions will be dedicated to long slits, while one mask providing the low spectral resolution of $R \sim 100$ (the baseline is a dispersing prism), and another mask providing the medium spectral resolution of $R \sim 1500$ (the baseline is a GRISM) will be accommodated in the pupil plane wheel. The implementation of two orthogonal focal plane slits is recommended to properly orient the mask on the object of interest (a known planet, for example), considering that we have a max bearing rotation of 185° and to ensure a minimum residual derotation of 90° for the observation without changing to the perpendicular slit.

The total throughput with the Prism is of the order of 55-64%, while with the GRISM is about 35-40%.

5. OVERVIEW OF THE SHARK-NIR OPTO-MECHANICAL DESIGN

We give in this section an overview of the opto-mechanical design of SHARK, showing the main subsystems of the instrument, and recalling its main characteristics. The instrument is designed to operate in the wavelength range going from $0.96\mu\text{m}$ to $1.7\mu\text{m}$.

The optical design is shown in Figure 4, the full circular FoV is of the order of $15''$ ($\sim 21.5''$ on the diagonal), and the main characteristics are described in the following.

An off-axis parabola (OAP-1) is creating a pupil plane of about 12mm of diameter onto a local DM, which has the purpose to locally remove the . A possible local DM to be used has already been identified, the ALPAO 97-15, characterized by a maximum pupil size of 13.5mm in diameter, by 97 actuators (normally the NCPA correction is limited to the first 15-20 modes), a large PtoV stroke of the actuators of about $40-60\mu\text{m}$ and a bandwidth of about 750Hz. A detailed evaluation of the expected NCPA will be carried on and, in case it will turn out to be a reasonably small amount,

the local DM will be replaced with a Tip-Tilt mirror, to be used at low frequency to maintain the focal plane masks alignment during the scientific exposure, by closing the loop on the Tip Tilt (TT) sensor described in the following.

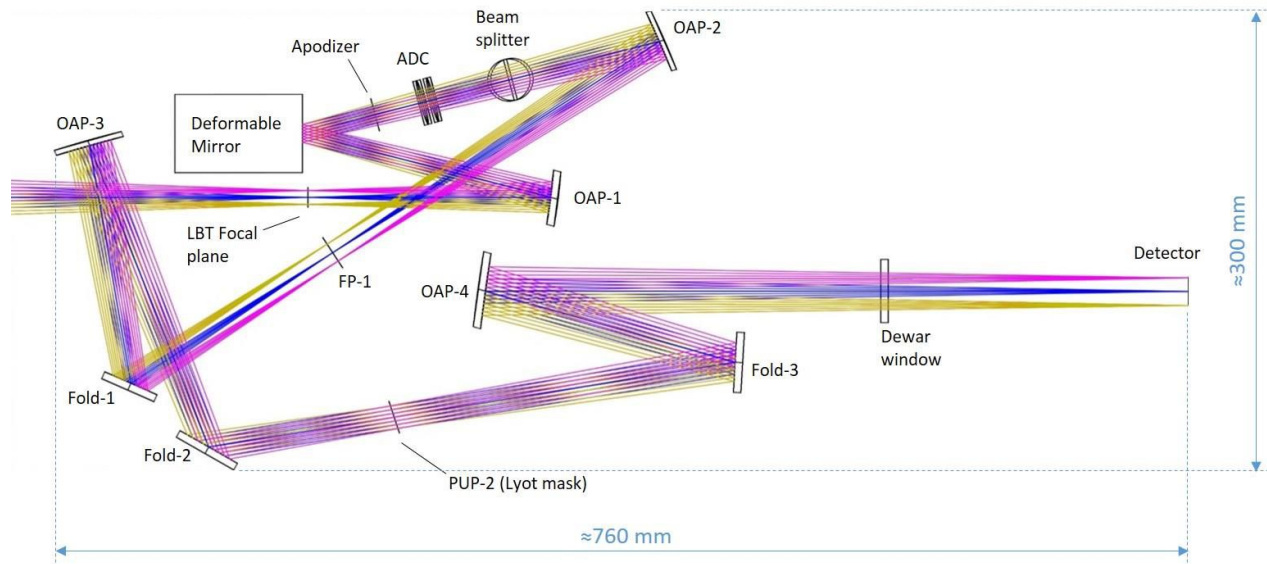

Figure 4: the optical design of SHARK-NIR

A filter wheel will select between different apodizing masks, which are positioned 50mm after the pupil plane.

Immediately after, in the collimated beam, the ADC is placed.

To optimize the system performance, the ADC is deployable, in a way to optimize the system performance at observing altitudes which do not require the correction (normally for zenithal distances smaller than 25°-30°).

Between the ADC and the second off-axis parabola (OAP-2), a beam splitter is placed to send a small portion of the light (~5%) to a very simple tip-tilt sensor (which is placed in vertical position with respect to the plane of the drawing), composed of a lens and a commercial detector sensitive to J band. The TT sensor gives the advantage to monitor (at low frequency, once every minute for example) possible drift of the spot during a single exposure, to be then compensated with the local DM, ensuring in this way to maintain the proper mask alignment.

OAP-2 is refocusing the beam on an intermediate focal plane (FP-1), where a filter wheel can select between different occulting masks (10 positions are foreseen). The same wheel accommodates a couple of low spectral resolution grism (R~100 and R~1000), to do spectral characterization of the science targets.

After a folding mirror, a 3rd off-axis parabola is creating the 2nd re-imaged pupil plane, where a filter wheel (9 positions foreseen) can select between different pupil stops used to properly mask the spiders and the secondary mirror, to minimize diffraction effects. On the same collimated beam, two additional filter wheels (positioned between the pupil plane and a folding mirror, Fold-3) will allow the insertion of seven scientific filters each. They both have eight positions.

After a folding mirror, the fourth off-axis parabola (OAP-4) is creating the final focal plane onto the detector, where the diffraction limit PSF is Nyquist sampled at 1micron. A deployable small optical group, not shown in Figure 4, can be inserted between OAP-4 and the cryostat window, with the purpose to create an image of the pupil onto the detector, which can be used before each scientific exposure to properly calibrate and compensate pupil shifts.

The whole bench is installed on a mechanical bearing, ensuring the field rotation whenever required from the science cases.

The entrance window of the camera dewar is kept at 200mm of distance from the detector, being 180mm the minimum length of the baffle which has to be implemented in front of the camera to minimize the thermal background.

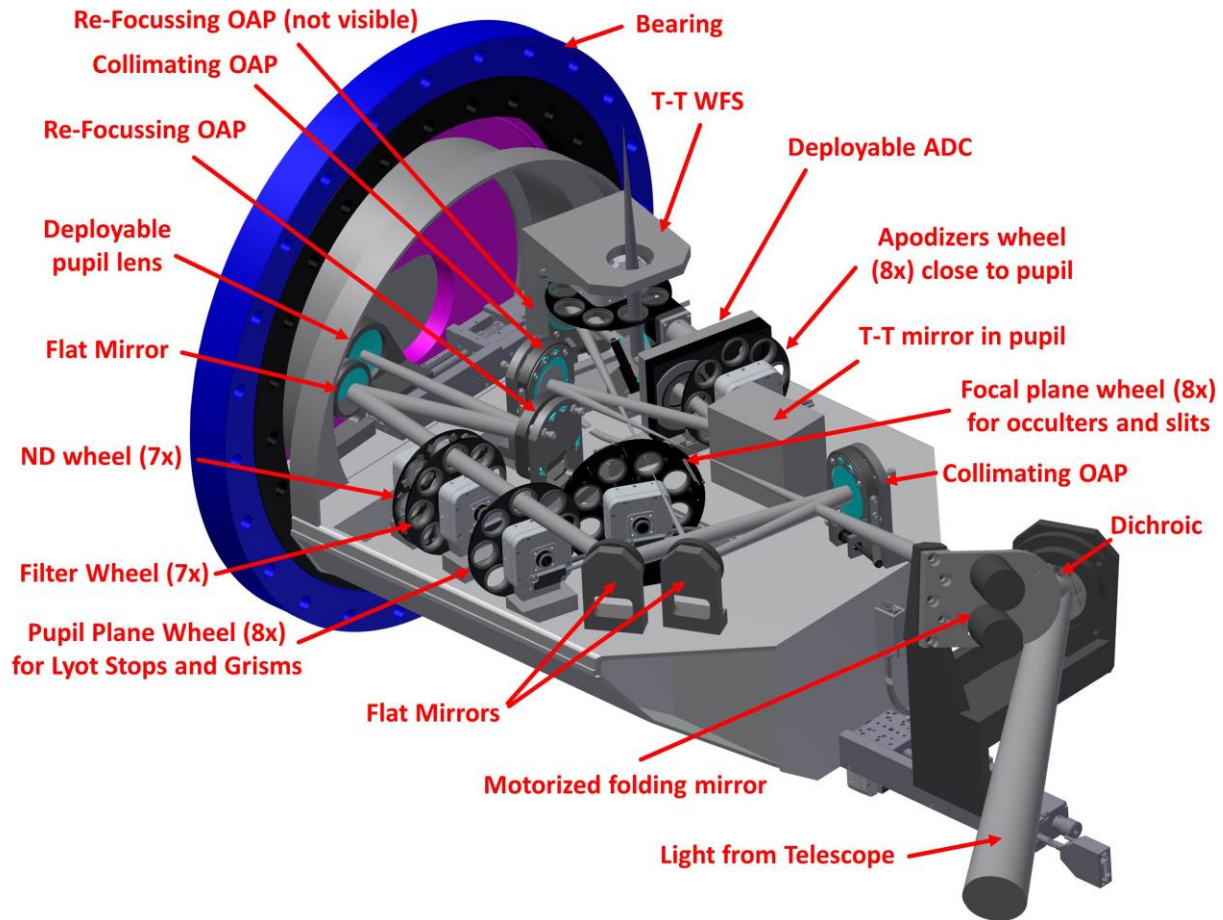

Figure 5: the opto-mechanical concept of the SHARK-NIR optical bench

The camera (not shown in the 3-D view of Figure 5) is Cryogenic, and will be using an HAWAII II detector. The LN₂ tank shall ensure a hold time of about 28 hours.

6. CONCLUSIONS

The synergy between SHARK-NIR, SHARK-VIS channel and LMIRcam will allow LBT to make contemporary binocular coronagraphic direct imaging observations in three different wavelengths, giving unique opportunities to exploit at best the very challenging exo-planet case.

The high sensitivity of the AO system in the faint end regime, which will be further increased by SOUL, will give to LBT a huge advantage with respect to any other similar system operating nowadays, opening to science never explored before in coronagraphic direct imaging. In fact, this magnitude gain will increase a lot the sample of possible exoplanetary systems to be exploited, and will allow to make also extra-galactic science by characterizing for example the morphology of faint targets such as AGN and QUASARS.

The new design proposed for the CDR is noticeable simpler than the previous one, meaning a much faster project development, which is foreseen to have first light at LBT in fall 2018.

REFERENCES

- [1] Farinato, J.; Pedichini, F.; Pinna, E.; Baciotti, F.; Baffa, C.; Baruffolo, A.; Bergomi, M.; Bruno, P.; Cappellaro, E.; Carbonaro, L.; Carlotti, A.; Centrone, M.; Close, L.; Codona, J.; Desidera, S.; Dima, M.; Esposito, S.; Fantinel, D.; Farisato, G.; Fontana, A.; Gaessler, W.; Giallongo, E.; Gratton, R.; Greggio, D.; Guerra, J. C.; Guyon, O.; Hinz, P.; Leone, F.; Lisi, F.; Magrin, D.; Marafatto, L.; Munari, M.; Pagano, I.; Puglisi, A.; Ragazzoni, R.; Salasnich, B.; Sani, E.; Scuderi, S.; Stangalini, M.; Testa, V.; Verinaud, C.; Viotto, V.; “SHARK (System for coronagraphy with High order Adaptive optics from R to K band): a proposal for the LBT 2nd generation instrumentation”, SPIE Proc. 9147, id. 91477J 10 pp. (2014).
- [2] Hill, J. M. and Salinari, P., “Large Binocular Telescope project,” Proc. SPIE, 4004, 36–46 (2000).
- [3] Stangalini, M.; Pedichini, F.; Centrone, Mauro; Esposito, S.; Farinato, J.; Giallongo, E.; Quirós-Pacheco, F.; Pinna, E.; “The solar system at 10 parsec: exploiting the ExAO of LBT in the visual wavelengths”, SPIE Proc. 9147, id. 91478F 7 pp. (2014).
- [4] Farinato, J., Baffa, C., Baruffolo, A., Bergomi, M., Carbonaro, L., Carlotti, A., Centrone, M., Codona, J., Dima, M., Esposito, S., Fantinel, D., Farisato, G., Gaessler, W., Giallongo, E., Greggio, D., Hink, P., Lisi, F., Magrin, D., Marafatto, L., Pedichini, F., Pinna, E., Puglisi, A., Ragazzoni, R., Salasnich, B., Stangalini, M., Verinaud, C. and Viotto, V., “The NIR arm of SHARK (System for coronagraphy with High order Adaptive optics from R to K band)”, International Journal of Astrobiology, 14(3), 365-373 (2015)
- [5] Esposito, S., Riccardi, A., Pinna, E., Puglisi, A. T., Quirós-Pacheco, F., Arcidiacono, C., Xompero, M., Briguglio, R., Busoni, L., Fini, L., Argomedo, J., Gherardi, A., Agapito, G., Brusa, G., Miller, D. L., Guerra Ramon, J. C., Boutsia, K. and Stefanini, P. “Natural guide star adaptive optics systems at LBT: FLAO commissioning and science operations status”, Proc. SPIE, 8447, 84470U (2012)
- [6] Ragazzoni, R., “Pupil plane wavefront sensing with an oscillating prism,” Journal of Modern Optics 43, 289 (1996).
- [7] Riccardi, A.; Xompero, M.; Briguglio, R.; Quirós-Pacheco, F.; Busoni, L.; Fini, L.; Puglisi, A.; Esposito, S.; Arcidiacono, C.; Pinna, E.; Ranfagni, P.; Salinari, P.; Brusa, G.; Demers, R.; Biasi, R.; Gallieni, D.; “The adaptive secondary mirror for the Large Binocular Telescope: optical acceptance test and preliminary on-sky commissioning results”, SPIE 7736, 79 (2010)
- [8] Hinz, P.M., Angel, J.R.P., McCarthy, D.W., Hoffman, W.F., and Peng, C.Y., “The large binocular telescope interferometer,” in Proc. SPIE, 4838, 108 (2003).
- [9] Pinna, E., Pedichini, F., Farinato, J., Esposito, S., Centrone, M., Puglisi, A., Carbonaro, L., Agapito, G., Riccardi, A., Xompero, M., Hinz, P., Montoya, M., and Bailey, V., “XAO at LBT: current performances in the visible and upcoming upgrade,” Proc. of AO4ELT4 conference.
- [10] Ragazzoni, R.; Farinato, J.; “Sensitivity of a pyramidal Wave Front sensor in closed loop Adaptive Optics”, A&A, 350, L23 (1999)
- [11] Verinaud, C.; Le Louarn, M.; Korkiakoski, V.; Carbillet, M.; “Adaptive optics for high-contrast imaging: pyramid sensor versus spatially filtered Shack-Hartmann sensor”, MNRAS, 357, L26 (2005)
- [12] Esposito, S.; Riccardi, A.; “Pyramid Wavefront Sensor behavior in partial correction Adaptive Optic systems”, A&A, 369, L9 (2001)
- [13] Costa, Joana B.; Feldt, Markus; Wagner, Karl; Bizenberger, Peter; Hippler, Stefan; Baumeister, Harald; Stumpf, Micaela; Ragazzoni, Roberto; Esposito, Simone; Henning, Thomas; “Status report of PYRAMIR: a near-infrared pyramid wavefront sensor for ALFA”, SPIE Proc. 5490, 1189 (2004)

- [14] Ghedina, Adriano; Cecconi, Massimo; Ragazzoni, Roberto; Farinato, Jacopo; Baruffolo, Andrea; Crimi, Giuseppe; Diolaiti, Emiliano; Esposito, Simone; Fini, Luca; Ghigo, Mauro; Marchetti, Enrico; Niero, Tiziano; Puglisi, Alfio; "On Sky Test of the Pyramid Wavefront Sensor", SPIE Proc. 4839, 869 (2003)
- [15] Beuzit, J.-L., Boccaletti, A., Feldt, M., Dohlen, K., Mouillet, D., Puget, P., Wildi, F., Abe, L., Antichi, J., Baruffolo, A., Baudoz, P., Carbillet, M., Charton, J., Claudi, R., Desidera, S., Downing, M., Fabron, C., Feautrier, P., Fedrigo, E., Fusco, T., Gach, J.-L., Giro, E., Gratton, R., Henning, T., Hubin, N., Joos, F., Kasper, M., Lagrange, A.-M., Langlois, M., Lenzen, R., Moutou, C., Pavlov, A., Petit, C., Pragt, J., Rabou, P., Rigal, F., Rochat, S., Roelfsema, R., Rousset, G., Saisse, M., Schmid, H.-M., Stadler, E., Thalmann, C., Turatto, M., Udry, S., Vakili, F., Vigan, A., and Waters, R. "Direct detection of giant extrasolar planets with SPHERE on the VLT," *Astronomical Society of the Pacific workshop Proc.*, 430, 231 (2010).
- [16] Macintosh, B.A., Graham, J.R., Palmer, D.W., Doyon, R., Dunn, J., Gavel, D.T., Larkin, J., Oppenheimer, B., Saddlemyer, L., Sivaramakrishnan, A., Wallace, J.K., Bauman, B., Erickson, D.A., Marois, C., Poyneer, L.A., and Soummer, R. "The Gemini Planet Imager: from science to design to construction," in *Proc. SPIE*, 7015, 31 (2008).
- [17] Guyon, O.; Martinache, F.; Clergeon, C.; Russell, R.; Groff, T.; Garrel, V.; "Wavefront control with the Subaru Coronagraphic Extreme Adaptive Optics (SCEXAO) system", *SPIE Proc.* 8149, 894293 (2011)