



Publication Year	2017
Acceptance in OA	2020-07-24T09:15:43Z
Title	The Camera Server of the ASTRI SST-2M Telescopes Proposed for the Cherenkov Telescope Array
Authors	CONFORTI, Vito, TRIFOGLIO, MASSIMO, GIANOTTI, FULVIO, MALAGUTI, GIUSEPPE, BULGARELLI, ANDREA, FIORETTI, VALENTINA, Zoli, A., CATALANO, OSVALDO, CAPALBI, Milvia, SANGIORGI, Pierluca
Handle	http://hdl.handle.net/20.500.12386/26612
Serie	ASTRONOMICAL SOCIETY OF THE PACIFIC CONFERENCE SERIES
Volume	512

The Camera Server of the ASTRI SST-2M Telescopes Proposed for the Cherenkov Telescope Array

V. Conforti,¹ M. Trifoglio,¹ F. Gianotti,¹ G. Malaguti,¹ A. Bulgarelli,¹ V. Fioretti,¹
A. Zoli,¹ O. Catalano,² M. Capalbi,² P. Sangiorgi,² and
the ASTRI Collaboration³ and CTA Consortium⁴

¹*INAF IASF, Via Gobetti 101, Bologna, Italy;*

²*INAF IASF, Via Ugo La Malfa 153, Palermo, Italy;*

³ <http://www.brera.inaf.it/astri/>

⁴ <https://www.cta-observatory.org/>

Abstract. The Cherenkov Telescope Array (CTA) project is an international initiative to build the next generation of ground-based very high energy gamma-ray instrument. Three classes of telescopes with different mirror size will cover the full energy range from tens of GeV up to hundreds of TeV. The full sky coverage will be assured by two arrays, with one site located in each of the northern and southern hemispheres. In the current design scenario, the southern hemisphere array of CTA will include seventy small size telescopes (SST, 4m diameter) covering the highest energy region. Their implementation includes proposed intermediate steps with the development of mini-arrays of telescope precursors like the ASTRI mini-array, led by the Italian National Institute for Astrophysics (INAF) in synergy with the Universidade de Sao Paulo (Brazil) and the North-West University (South Africa). The ASTRI mini-array will be composed of nine telescope units (ASTRI SST-2M) based on double-mirror configuration whose end-to-end prototype has been installed on Mt. Etna (Italy) and is currently undergoing engineering tests. In the ASTRI SST-2M prototype, operating in single telescope configuration, the basic camera server software is being deployed and tested; it acquires the data sent by the camera back end electronics as a continuous stream of packets. In near real time, the bulk data of a given run are stored in one raw file. In parallel they are sorted by data type, converted to FITS format and stored in one file for data type. Upon closure, each file is transferred to the on-site archive. In addition, the quick look component allows the operator to display the camera data during the acquisition. This contribution presents how the camera server software of the prototype is being upgraded in order to fulfil the mini-array requirements, where it will be deployed on the camera server of each ASTRI SST-2M telescope. Particular emphasis will be devoted to the most challenging requirements that are related to the stereoscopy, when two or more telescopes have triggered simultaneously. To handle stereoscopy, each camera server has also to: (i) get the timestamp information from the clock distribution and trigger time stamping system, and associate it to the related camera event; (ii) get from the software array trigger the timestamp which passed the stereo trigger criteria; and (iii) forward to the array data acquisition system the stereo trigger events, according to the required data format and communication protocol.

1. Introduction

The Italian National Institute for Astrophysics (INAF) is leading the ASTRI project (Pareschi et al. 2013) proposed for the ambitious Cherenkov Telescope Array (CTA, Acharya et al. 2013).

In the framework of the small size class of telescopes (Montaruli et al. 2015), a first goal of the ASTRI project is the realization of an end-to-end prototype in a dual-mirror configuration (SST-2M) with the camera at the focal plane composed of a matrix of Silicon photo-multiplier sensors managed by innovative front-end and back-end electronics (Canestrari et al. 2014; Catalano et al. 2014). The ASTRI SST-2M prototype is installed in Italy at the INAF “M.G. Fracastoro” observing station located at Serra La Nave, 1735 m a.s.l. on Mount Etna, Sicily. As a second step, the ASTRI project is addressed to the implementation of the ASTRI mini-array (Vercellone et al. 2013) composed of nine SST-2M telescopes and proposed to be placed at the CTA southern site. A first version of the software to be installed on the camera server of the ASTRI SST 2M prototype is being deployed and tested, and will be integrated on site by the end of this year (Conforti et al. 2014). It is aimed at the acquisition, storage and display of the camera data. This version is being re-engineered for the mini-array configuration, where the camera server has to interface with the array control and data acquisition (ACTL) system (Oya et al. 2015). In this configuration the camera server provides a different management of the event time stamping and forwards the stereo triggered events to the array data acquisition (DAQ) pipeline. In this paper we present an overview of the preliminary architecture of the camera server software envisaged for the ASTRI mini-array (Tosti et al. 2014).

2. The Component and Connector View

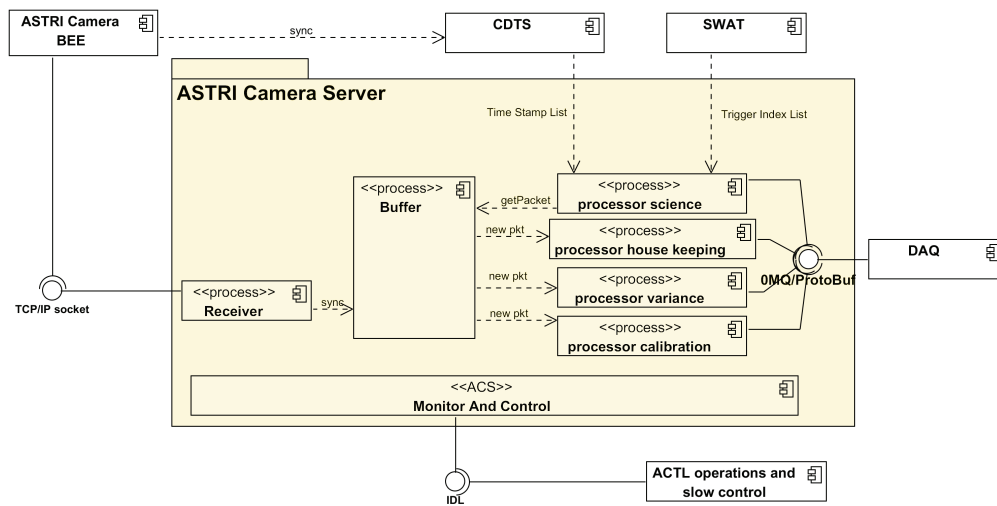

Figure 1. UML Component Diagram

The component diagram in Figure 1 shows how the camera server software is structured as a set of elements with run time behaviors and interactions. The receiver component of the camera server acquires the bulk data (events, calibration, housekeeping and variance) from the camera Back End Electronics (BEE) through a TCP/IP socket connection (Trifoglio et al. 2015). For each camera trigger event (science), the camera server receives the related high precision timestamp generated by the Clock Distribution and Trigger time Stamping (CDTS) system, and associates it to the event. During the operations in array configuration, the camera server receives from the SoftWare Array Trigger (SWAT) the list of science events that participate to a stereo triggered events. These events, and all the other events that are flagged either by the Camera as interleaved calibration or by the Camera Server as possible mono-muons, are sent to the Array DAQ. The remaining events are discarded. A suitable buffer is provided to perform all these operations on all the forthcoming events. The buffer dimension depends on the predefined

nominal rate and time window. Before forwarding to the array DAQ, the data are prepared by the processors according to a data format common to all the telescopes. The interface between camera and camera server for the bulk data transmission is well defined and it is being tested for the prototype (Conforti et al. 2014). A component is devoted to the monitor and control of the camera server and provides information to the ACTL operations and slow control systems. Details on this interface are still under discussion. The interface between the camera server and the array DAQ is being finalized through prototypes using the Google Protocol Buffer for the data format and the OMQ for the data transmission.

3. The Deployment View

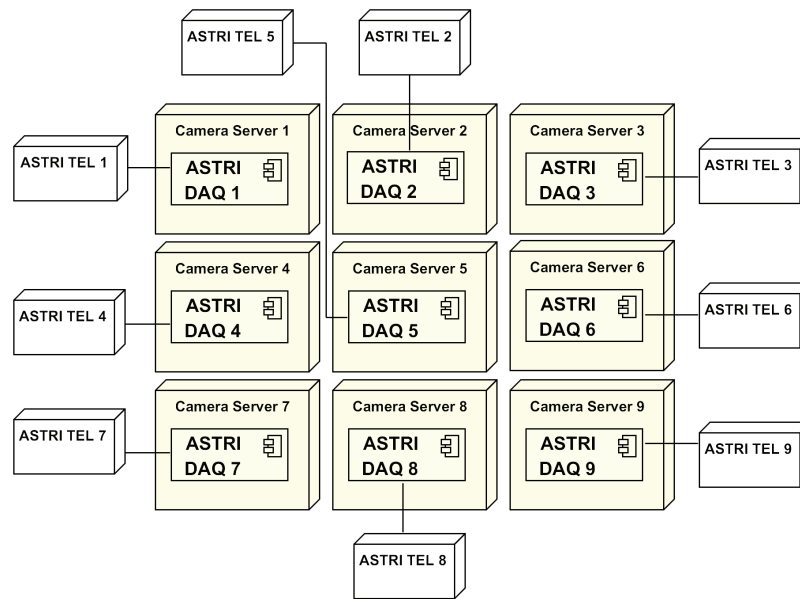

Figure 2. UML Deployment Diagram

The Figure 2 depicts the deployment view. It shows how the system relates to the software structures in its environment. The hardware architecture, within the CTA Consortium, is currently under definition in order to set the best common hardware configuration for all telescope camera servers. The ASTRI camera produces scientific data at 600 events per second. The bit rate is about 6 MB/s, thus it does not require very high computing performance. A good level of availability of the camera server software is crucial to minimize data losses. Hence we envisage one camera server for each ASTRI telescope. The following base line configuration has been identified and will be assessed through extensive tests: (i) x86 - 64 bit Architecture, (ii) at least a Xeon processor with a minimum of 6 cores, (iii) at least 4 GB Ram for each processor core, (iv) 2 slots for disks, (v) one 1 GB/s fiber connection for the bulk data acquiring, (vi) at least two 1 GB/s LAN, in bonding configuration, for control and monitoring, (vii) redundant power, and (viii) Intelligent Platform Management Interface (IPMI) capability for control and monitoring.

We are adopting an iterative incremental development model. For each step we are following the CTA specifications. Furthermore we are providing feedback in order to find the best solution to facilitate the procurement and maintenance activities.

4. Conclusions and plans

Based on the experience gained with the ASTRI SST-2M prototype, we have designed the camera server software proposed for the ASTRI mini-array as precursor of the CTA Observatory. The deployment of the first ASTRI mini-array software is foreseen in late 2016. The concept presented in this contribution will be finalised as soon as the interfaces with the external ACTL components are assessed.

Acknowledgments. This work was partially supported by the ASTRI “Flagship Project” financed by the Italian Ministry of Education, University, and Research (MIUR) and led by the Italian National Institute of Astrophysics (INAF). We acknowledge partial support by the MIUR Bando PRIN 2009 and TeChe.it 2014 Special Grants. We also acknowledge support from the Brazilian Funding Agency FAPESP (Grant 2013/10559-5) and from the South African Department of Science and Technology through Funding Agreement 0227/2014 for the South African Gamma-Ray Astronomy Programme. We gratefully acknowledge support from the agencies and organizations listed under Funding Agencies at this website: <http://www.cta-observatory.org/>.

References

- Acharya, B., et al. 2013, *Astroparticle Physics*, 43, 3 . Seeing the High-Energy Universe with the Cherenkov Telescope Array - The Science Explored with the {CTA}
- Canestrari, R., et al. 2014, in *SPIE Astronomical Telescopes and Instrumentation.*, vol. 9145, 91450M. URL <http://dx.doi.org/10.1117/12.2055805>
- Catalano, O., et al. 2014, in *SPIE Astronomical Telescopes and Instrumentation.*, vol. 9147, 91470D. URL <http://dx.doi.org/10.1117/12.2055099>
- Conforti, V., et al. 2014, in *SPIE Astronomical Telescopes and Instrumentation.*, vol. 9152, 91522D. URL <http://dx.doi.org/10.1117/12.2054519>
- Montaruli, T., Pareschi, G., & Greenshaw, T. 2015. 1508.06472
- Oya, I., et al. 2015. 1509.01164
- Pareschi, G., et al. 2013. 1307.4962
- Tosti, G., et al. 2014, in *SPIE Astronomical Telescopes and Instrumentation.*, vol. 9152, 915204. URL <http://dx.doi.org/10.1117/12.2055067>
- Trifoglio, M., et al. 2015, ASTRI Camera Server / ASTRI Camera Interface Control Document, technical report, INAF IASF Bologna
- Vercellone, S., et al. 2013. 1307.5671