



Publication Year	2003
Acceptance in OA	2023-02-14T17:13:22Z
Title	Planck sorption cooler engineering breadboard test report
Authors	James Borders, MORGANTE, GIANLUCA, David Pearson
Handle	http://hdl.handle.net/20.500.12386/33464
Volume	JPL 5-30

Planck Sorption Cooler

EBB Test Report

Doc. Type: Test Report

Issue/Rev.: Issue 1.0

Release Date: Monday, June 02, 2003

Prepared by: J. Borders, G. Morgante and D. Pearson

For CNES & related entries (IAS): This technical data is export controlled under U.S. law and is being transferred by JPL to CNES pursuant to the NASA / CNES Letter of Agreement which entered into force on January 27, 2000. This technical data is transferred to CNES for use exclusively on the NASA/CNES HFI on Planck cooperative project, may not be used for any other purpose, and shall not be re-transferred or disclosed to any other party without the prior written approval of NASA

For ASI & related entries (IASF): This technical data is export controlled under U.S. law and is being transferred by JPL to ASI pursuant to the NASA / ASI Letter of Agreement which entered into force on March 29, 2001. This technical data is transferred to LFI for use exclusively on the NASA/ASI LFI on Planck cooperative project, may not be used for any other purpose, and shall not be re-transferred or disclosed to any other party without the prior written approval of NASA.

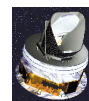

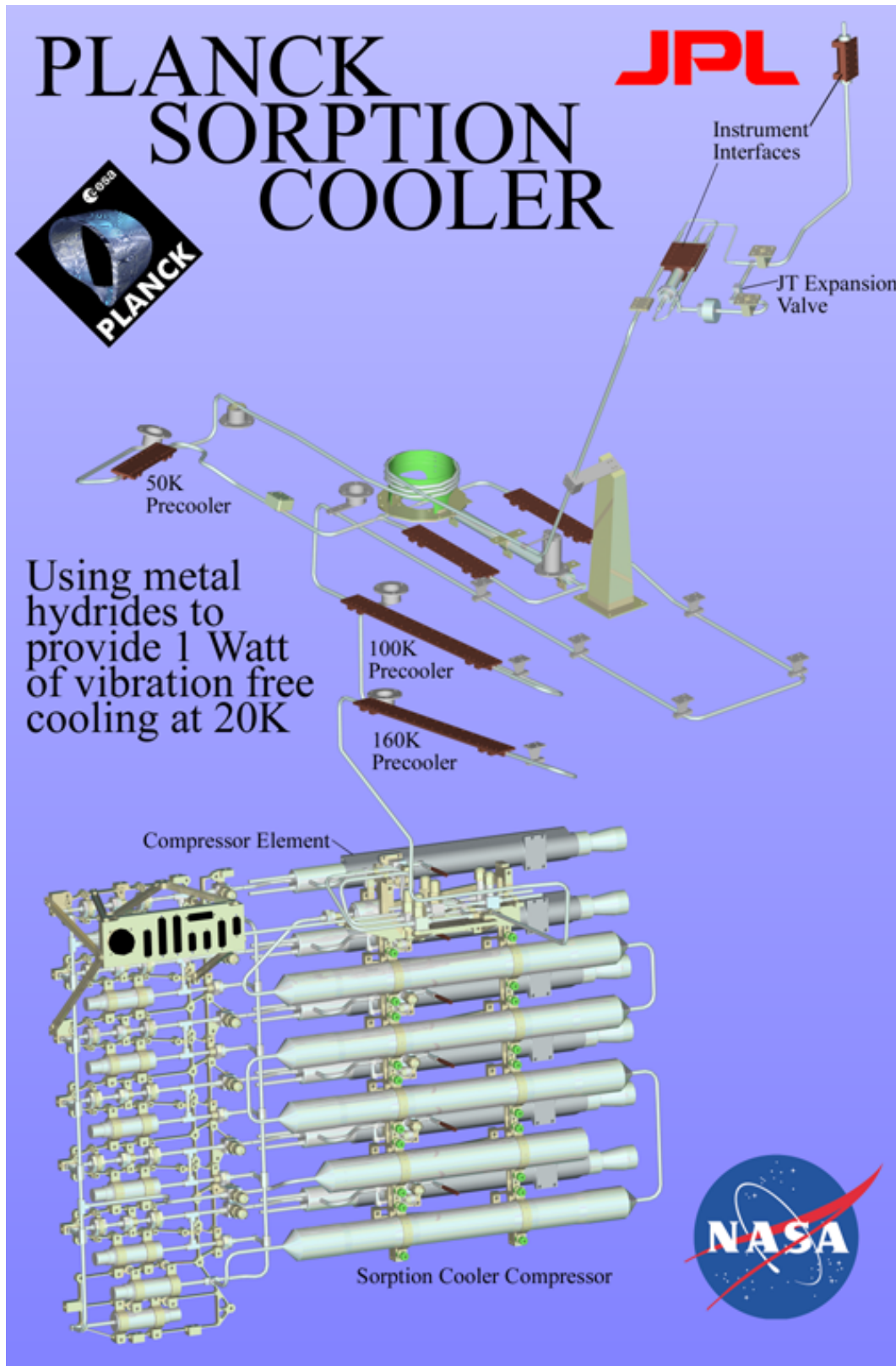

Figure A. Model of flight cooler

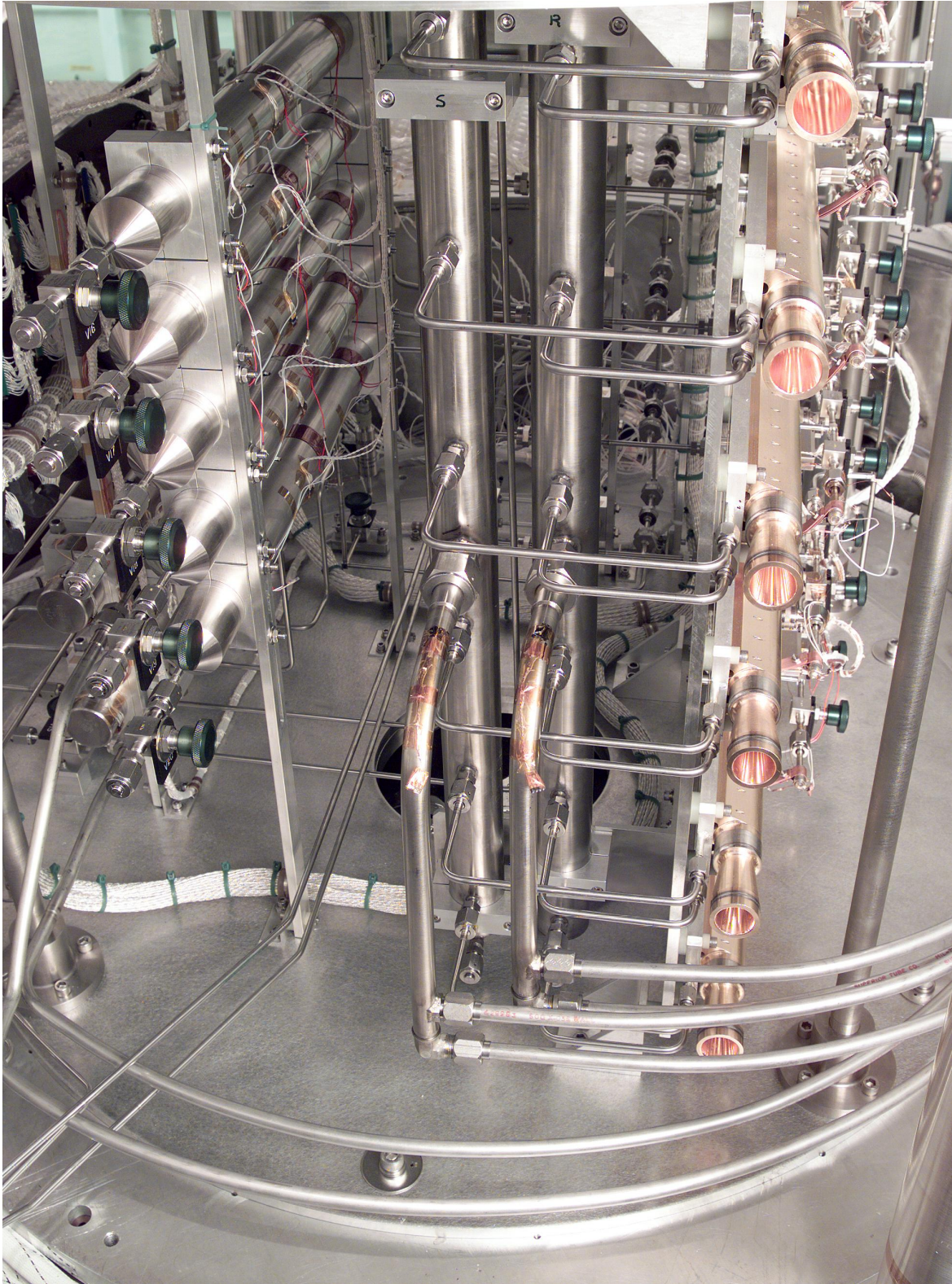

Figure B. Photograph of EBB compressor



Figure C. Photograph of 100K and 55K pre-coolers (PC2, PC3a, PC3b)

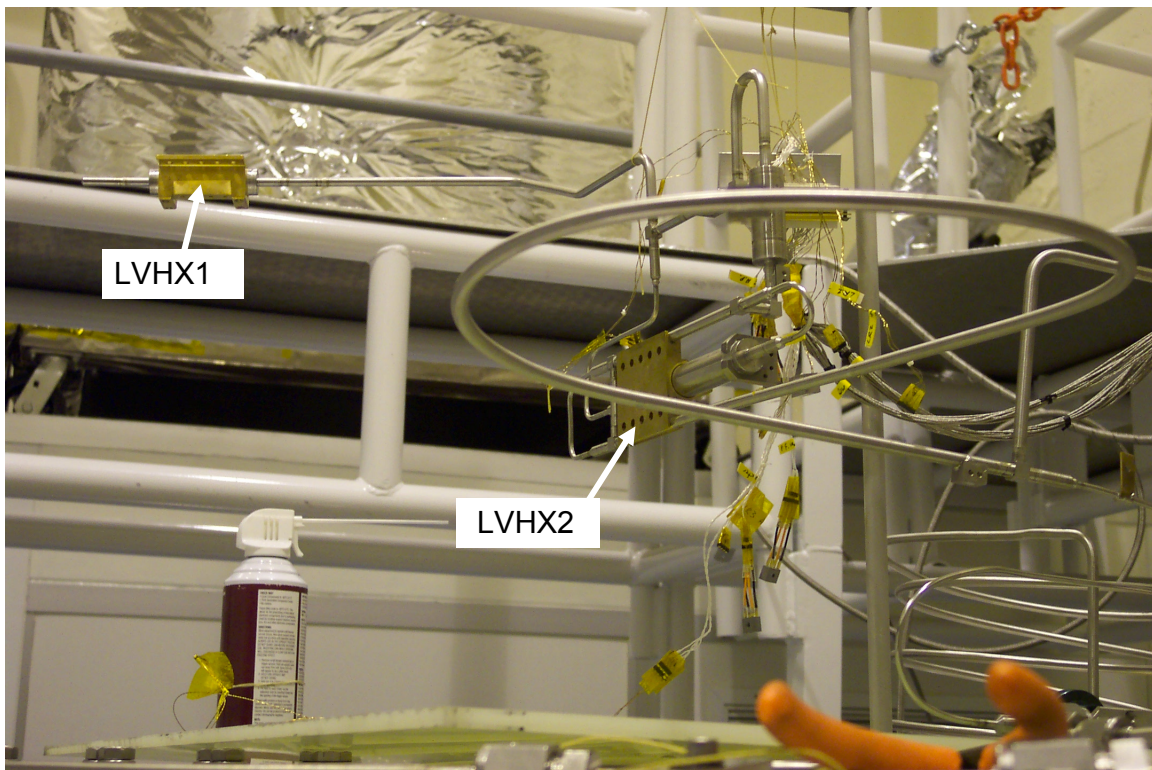

Figure D. Photograph of pathfinder flight-like cold end



Figure E. Photograph of Planck EBB test facility

Table of Contents

<i>Engineering Breadboard Sorption Cooler Overview</i>	8
<i>Planck Sorption Cooler Overview</i>	8
Planck Sorption Compressor	11
Piping Assembly and Cold End (PACE)	11
<i>EBB Cooler Description and Comparison to the Flight Cooler</i>	12
EBB Compressor (SCC)	13
EBB Piping Assembly and Cold End (PACE)	15
<i>Test Facility</i>	16
Comparison Between Test and Flight Interfaces	18
<i>EBB Cooler Testing</i>	19
Test History	19
Test Results	20
LVHX1 and LVHX2 Temperature	20
LVHX1 and LVHX2 Temperature Fluctuations	21
Cooling power	24
Validation of Cold End performance for operational conditions	25
Input power	26
Cooler pressurization with CONDITIONING mode	28
Contamination Analysis	29
<i>LPSC Electronics Testing</i>	29
September 2002	30
November 2002	30
May 2003	31
<i>Conclusions</i>	31
<i>References</i>	31

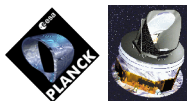

Table of Figures

Figure 1. Planck Sorption Cooler Schematic.....	9
Table 1. Planck Sorption Cooler Requirements.....	9
Figure 2. Cooler instrumentation diagram.....	10
Table 2a. Comparison of EBB and Flight compressors.....	13
Table 2b. Comparison of EBB and Flight PACE's.....	13
Table 2c. Comparison of EBB and Flight Cooler Interfaces.....	13
Table 3. Piping length comparison.....	15
Figure 3. Pathfinder cold end model.....	16
Figure 4. Planck sorption cooler test facility.....	17
Table 4. EBB cooler testing timeline.....	19
Table 5. Summary of EBB cooler test results.....	20
Figure 6. LVHX temperatures and LPSB pressure.....	21
Figure 7. Dependence of LVHX temperature and fluctuations on LPSB power.....	22
Figure 8. Liquid-vapor heat exchanger temperature fluctuations.....	23
Figure 9. Comparison of controlled and uncontrolled LVHX fluctuations.....	23
Figure 10. Cooling power data for 60K pre-cooler.....	25
Figure 11. Effects of HPST tanks on pressure and temperature fluctuations.....	26
Figure 12. Successful automatic defrost of plugged JT.....	27
Figure 13. Cooler pressurization with CONDITIONING mode.....	28

Engineering Breadboard Sorption Cooler Overview

In order to validate the sorption cooler flight design, an Engineering Breadboard (EBB) cooler was developed. Testing of the EBB cooler began in January, 2002, and ended in May, 2003. Throughout this period, the cooler was operated for a total of 4300 hours, during which its performance was verified with respect to the flight requirements. Prior to its construction, all of its components and sub-assemblies were tested individually. Interaction among these subsystems was yet to be validated. The EBB provided this system test prior to the construction of the flight models. In addition, operation of the EBB was used to develop robust operational algorithms, which were implemented in the flight prototype electronics. The prototype electronics were validated by testing with the EBB cooler. All the components for the flight cooler have been built to be functionally equivalent to those of the EBB, with a few exceptions. For this reason, the subassembly interactions and performance in the EBB are considered to be representative of those expected of the flight models. The impact of the differences between the EBB and flight models will be assessed in the following sections.

All lessons learned from the EBB tests were implemented in the design and operation of the flight cooler.

The report begins with an overview of the Planck flight cooler. Following this a comparison between flight and the EBB cooler. The test facility is described with particular emphasis on how it simulates the spacecraft interfaces. Test results are then presented with a focus on the four main cooler requirements:

- Cooling Power
- Input Power
- Temperature
- Temperature Fluctuations

Next a brief description of the cooler operating modes, contamination mitigation, and degraded operation is given. Finally, results of testing with the flight prototype electronics are described.

Planck Sorption Cooler Overview

The Planck Sorption Cooler uses isenthalpic (Joule-Thomson) expansion of hydrogen gas to produce approximately 1 W of heat lift at ≤ 19 K. A six-element sorption compressor is used to produce a pressure of 4.8MPa. The Joule-Thomson expander is chosen for a mass flow rate of 6.5 mg/s. To provide the required cooling the high-pressure gas needs to be cooled to below 60 K. This is accomplished with a counterflow tube-in-tube heat exchanger and three pre-cooling stages, nominally the temperatures of the pre-coolers are 155, 115, and 55K. With the pressure and mass flow, the temperature of the coldest pre-cooler determines the amount of cooling power while the higher temperature pre-coolers reduce the amount of heat released at the last pre-cooler. To provide independent temperatures for the two Planck instruments, two liquid-vapor heat exchangers (LVHX1 and LVHX2) are used to remove heat from the instruments.

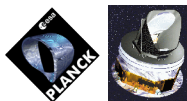

Temperature stability is obtained by maintaining the vapor pressure constant by compressor element absorption. During absorption, heat is rejected to a radiator whose temperature is crucial for determining the absorption pressure and in turn the temperature and temperature stability of the two instruments. The performance of the cooler depends critically on two boundary conditions: the last pre-cooling stage temperature, and the radiator temperature. The requirements for the cooler are given in Table 1 with the operating range of the two boundary conditions. Figure 1 is a schematic depiction of the cooler and Figure 2 shows the cooler instrumentation.

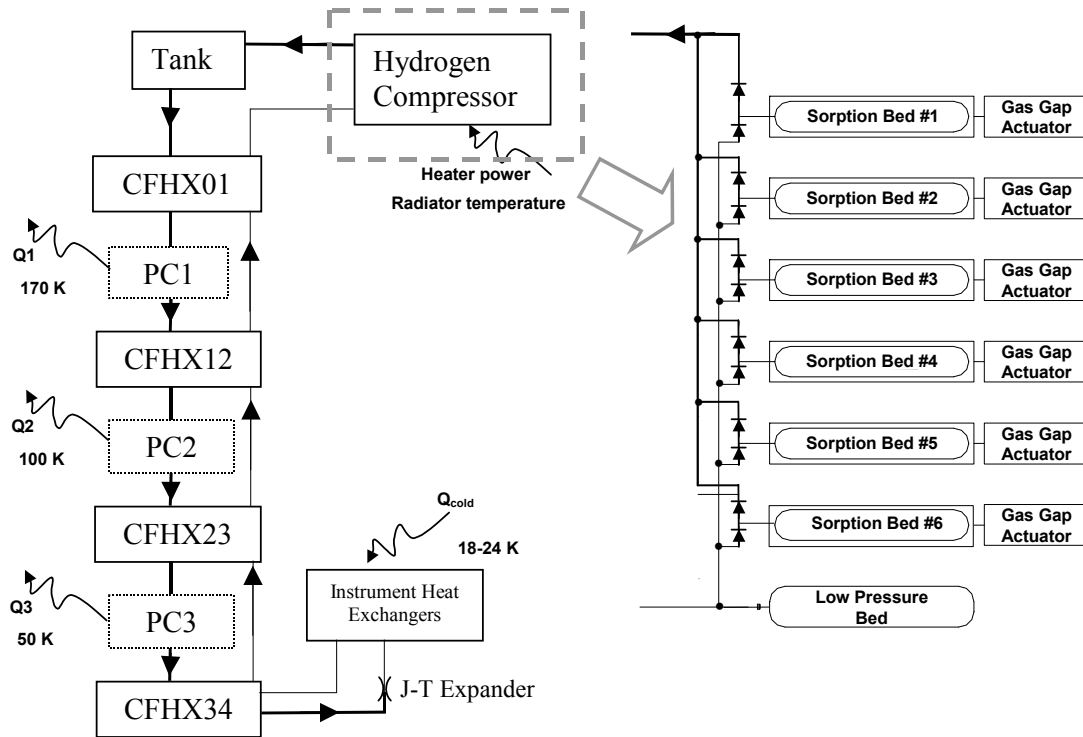

Figure 1. Planck Sorption Cooler Schematic

Planck Cooler Requirements listed in TMU Spec	
LVHX1 Interface Temperature	< 19 K
LVHX2 Interface Temperature	< 22.5 K
LVHX1 Interface Fluctuations*	< 250 mK (TBC)*
LVHX2 Interface Fluctuations**	< 250 mK (TBC)**
LVHX1 Cooling Power	> 151 mW
LVHX2 Cooling Power	> 835mW
Input Power	< 470 W
Operational Lifetime	24 Months

* a waiver has been submitted to HFI by JPL requesting the LVHX1 I/F Fluctuation requirement be relaxed to 450mK

** LFI has requested that JPL attempt to achieve LVHX2 I/F Fluctuations below 100mK

Table 1. Planck Sorption Cooler Requirements

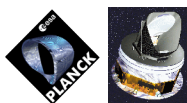

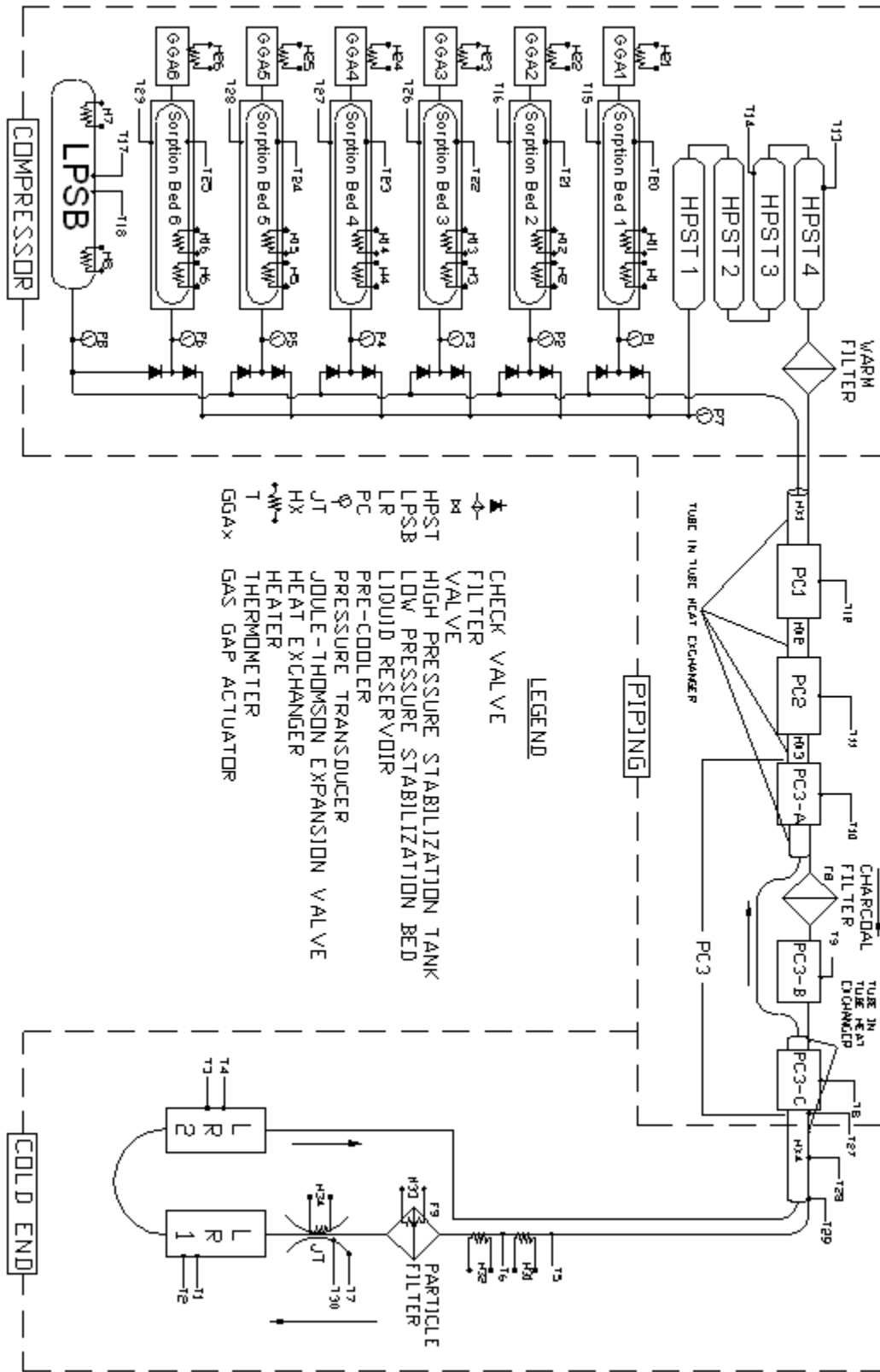

Figure 2. Cooler instrumentation diagram

Planck Sorption Compressor

The “engine” of the cryocooler is the sorption compressor. It serves two main functions: 1) production of high-pressure hydrogen gas flow at ~4.8 MPa; and 2) to maintain a stable gas recovery rate, which keeps the return pressure, and thus the liquid temperature, constant. This is done by the use of compressor elements (or “beds”) whose principle of operation is based on the properties of a unique sorption material that is able to absorb large amounts of hydrogen isothermally at relatively constant pressure and to desorb high-pressure hydrogen when heated to around 200 C. Heating of the sorbent material is accomplished by electrical resistance heaters while the cooling is achieved by thermally connecting the compressor element to a radiator sized to reject the cooler input power at 270 K \pm 10 K. Six compressor elements are required for the compressor to operate cyclically. At any moment one bed is releasing gas (desorption) at 5 MPa, three are absorbing gas to maintain the vapor pressure constant, while the other two beds are being heated and cooled in preparation for desorption and absorption respectively. The ability of the compressor to maintain the vapor pressure of the liquid constant is determined by the absorption properties of the sorbent material. As a compressor element fills with hydrogen, the pressure will rise slightly and this is the main source of temperature fluctuations at the LVHX’s. The cycle time of the compressor is 667 s and is determined by the cooler requirements and the 60-second spin cycle of the Planck spacecraft.

As each compressor element undergoes the cyclic heating and cooling, a gas-gap heat switch is used to couple or decouple the compressor element to the radiator depending on its state. The heat switches use a sorbent material that when heated releases gas to turn the switch “on” and when cooled reabsorbs the gas to isolate the element. During the heatup and desorption cycles the heat switch is “off”, while during the cooldown and absorption cycles the heat switches are “on”.

The compressor also includes four 1-liter tanks on the high-pressure side of the compressor (HPST). These tanks serve as a gas ballast to smooth mass flow variations due to the desorbing compressor elements. On the low pressure side of the compressor is a low pressure storage bed (LPSB) that stores hydrogen gas when the cryocooler is not operating to keep the system pressure below 1 Bar. Additionally, the LPSB stores gas that is evolved as the cooler ages. Two heaters are mounted to the LPSB. One is used in nominal operation to control the gas concentration in the compressor elements, while the second is used when the cooler is started to move gas from the LPSB to the HPST. Check valves direct flow out of the compressor elements into the HPST and control flow from the low pressure manifold and the LPSB back into the absorbing beds.

Piping Assembly and Cold End (PACE)

The piping assembly and cold end comprise the two main parts of the PACE. The piping assembly consists of a tube-in-tube heat exchanger and three pre-cooler interfaces. This assembly serves to pre-cool the high-pressure gas stream to below 60 K to produce the required cooling power. The three pre-coolers in flight will attach to V-groove radiator panels with

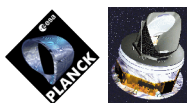

nominal temperatures of 155 K (PC1), 110 K (PC2), and 55 K (PC3). For PC3, three stages are implemented to distribute the heat into the radiator panel. A carbon cold trap is also located on the coldest radiator to remove condensable contaminants from the high pressure gas stream.

The second assembly, the cold-end, consists of the Joule-Thomson (JT) expander, two liquid-vapor heat exchangers, and an assembly (formerly known as LR3), to heat balance the cold end. The JT expander is selected to produce a flow of 6.5 mg/s +/- 5% for an input pressure of 4.8 MPa. The first liquid-vapor heat exchanger, LVHX1, attaches to the HFI instrument, and is designed to provide a temperature lower than 19 K with 150 mW of cooling power. The second LVHX, attaches to the LFI instrument, and is designed to provide a temperature less than 22.5 K and 850 mW of cooling power. In addition, the high-pressure gas stream exchanges heat with LVHX2 to pre-cool the gas and maintain its temperature constant before passing through the JT expander. Other elements of the cold-end include a tube-in-tube heat exchanger that joins the last pre-cooler to the cold-end, and a particle filter that protects the JT expander.

The PACE is mostly passive in its operation except for heat balance function of LR3 discussed above, and the removal of contaminants from the particle filter and JT. Heaters are installed on these two elements that are energized to remove condensable gases that might restrict or stop gas flow. As with all cryogenic Joule-Thomson systems, the capability of heating and removing condensable gases is a crucial part of the cooler operation.

EBB Cooler Description and Comparison to the Flight Cooler

The EBB cooler was built to be functionally equivalent to the flight design, i.e. the ability of the cooler to meet the requirements listed in Table 1 when the two key interfaces are varied over the flight allowable ranges. The as-built EBB cooler is very similar to the flight design and the next sections will enumerate in detail the minor differences between the tested EBB cooler and the flight design. These differences are summarized in Tables 2a, 2b and 2c. Early EBB testing used a JT cryostat that was different in many respects from the flight design, but a flight-like path-finder cold-end, nearly identical to the flight design, has been recently been tested with the EBB compressor and piping. Results presented will focus on testing using this path-finder cold-end.

In general, the differences between the two designs can be categorized as follows:

- a) where the differences between them were deemed to be insignificant (by analysis or test) in terms of meeting requirements;
- b) where the differences are due to lessons learned during the EBB tests and implemented in the flight cooler design to insure that the flight cooler will meet its requirements.

	Differences between Flight and EBB	Effect on cooler performance	Effect on cooler operation
Gas Gap Actuators	Flight model has 10 times more hydride	Lifetime	Slower on-off response, higher power
LPSB thermal coupling to radiator	Flight model is highly decoupled	None	Lower power, slower equilibration
Number of HPST tanks	5 used in EBB, 4 for flight	Higher pressure (cooling power) fluctuations	None
Bed heater configuration	2 heating elements per bed in Flight vs. 1 in EBB	None	Different software implementation
Cooling of gas leaving CEs, cooled by warm radiator	In EBB gas is cooled by chiller plate; in Flight is cooled by parasitic path	Small increase in temperature fluctuations	None

Table 2a. Comparison of EBB and Flight compressors

	Differences between Flight and EBB	Effect on cooler performance	Effect on cooler operation
Piping length	EBB piping is longer but has less bends	Cold end temperature lower in flight	None
Parasitics	N/A	Accounted for in cooling power margin	None

Table 2b. Comparison of EBB and Flight PACE's

	Differences	Effect on cooler performance
Warm radiator	EBB has single chiller plate, no coupling between beds, thermal profile is different but is larger than TMU spec	Fluctuations on flight will be less than with EBB
160 and 100 pre-coolers	Not controlled	None
50 K pre-cooler	Spatial distribution	None
LVHX1	None	None
LVHX2	None	None

Table 2c. Comparison of EBB and Flight Cooler Interfaces

EBB Compressor (SCC)

As with the flight compressor, the EBB sorption compressor consists of six compressor elements, a set of high-pressure stabilization tanks (HPST) that forms the high pressure manifold, a low-pressure storage hydride bed (LPSB) that is the low pressure manifold, and a check valve assembly that couples the two manifolds to the compressor elements. Also, each

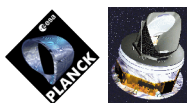

compressor element includes a hydride actuated gas-gap heat switch that thermally couples or isolates the compressor element from the warm radiator.

The EBB compressor element design is identical to the flight except for gold plating used in the EBB gas-gap volume and the electrical configuration of element heaters. The gold plating was used to reduce radiative heat parasitics but was removed because it was a source of contamination. Impact of the increased parasitics is about 10 W and is accounted for in the cooler power budget. In addition, the bed heater configuration is different in that for flight, two separate heater circuits are used, while in the EBB a single resistor is used. This does not impact cooler performance but only in cooler electronics implementation, i.e. two power circuits are needed to apply power in the flight design. The EBB compressor elements are instrumented with a thermocouple to measure the internal temperature of the element while a platinum resistance thermometer (PRT) mounted on the outer shell measures the external temperature. A pressure gauge (~68 bar) is located between the element and the check valve to measure the internal bed pressure. This instrumentation is identical to the flight design.

The EBB gas-gap heat switches are different from the flight in the amount of hydride material used. To increase lifetime 10 times more hydride material is used for the flight gas-gap heat switches. This was done to increase the hydrogen capacity to account for hydrogen permeation and outgassing into the gas gap volume. The impact of this is that more power is needed to heat the switch. This increase is again accounted for in the cooler power budget. For EBB testing, a PRT measures the temperature of each gas-gap body. These thermometers will not be used in flight.

The EBB compressor HPST consists of 5 one-liter tanks with valves that allows configuring of the HPST with 4, 3, or 2 tanks. The flight model is built with 4 one-liter tanks. The effect of reducing the volume of the HPST is to increase the high-pressure fluctuations and in turn to increase fluctuations in the cooling power available to the instruments. This does not affect the temperature or temperature fluctuations. Testing was done on the effect of tank reduction and will be discussed when results are presented on the cooling power. Each tank of the HPST is instrumented with a PRT. Two PRT's will be used on the flight HPST. As with the flight cooler, a pressure gauge (~68 bar) measures the pressure of the HPST tanks and the high-pressure manifold.

Another difference between the EBB and flight coolers in the HPST and the high-pressure manifold is the cooling of the gas stream leaving the compressor elements. As the gas stream exits a compressor element its temperature is about 470 K. For the EBB this exiting gas is cooled by heat exchange through blocks mounted to a large plate. In the flight design these blocks will not be used. Instead the four HPST tanks will be mounted to the warm radiator, thus the heat will be transferred from the gas stream to the warm radiator via the HPST.

Since all the HPST's are mounted on a structure that is thermally coupled to the CE's, this could potentially deposit this heat into the absorbing beds. Because the flow fluctuates, this heat deposition will also fluctuate, leading to a corresponding oscillation in the hydride temperature. This, in turn, would result in a small increase in the pressure fluctuations on the low-pressure side. These pressure variations would translate into additional temperature fluctuations at the cold end. Calculations were performed to quantify this effect. Assuming that all of this heat was deposited into the absorbing beds, the increase in cold end temperature fluctuations would be ~10 mK. This is a very conservative estimate in that it is highly unlikely that this heat would only be deposited into the absorbing elements. In reality, most of this heat would be transferred to the warm radiator at areas where the tanks are located via the common supporting structure,

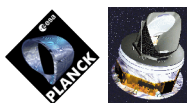

instead of only being deposited at the absorbing CE's. A more realistic calculation is expected to yield a much smaller increase in temperature fluctuations due to this effect, on the order of 1 or 2mK.

The EBB LPSB is practically identical to that used for the flight models, although the thermal connection to the radiator is different. For flight the LPSB will be more isolated, requiring 4 W to operate while the EBB LPSB required 10 W. The LPSB is instrumented with 3 PRT temperature sensors and 2 heaters. The 3 temperature sensors measure the outer shell of the LPSB. One heater is used during the transfer of gas from the LPSB to the HPST, and the other is used to control the compressor element concentration. A pressure sensor (~1.4 bar on EBB, ~3.5 bar on flight) measures the pressure of the LPSB and the low-pressure manifold.

EBB Piping Assembly and Cold End (PACE)

The piping assembly and cold end form the two main parts of the PACE. The piping assembly consists of a tube-in-tube counter-flow heat exchanger and three pre-cooling stages, PC1, PC2, PC3. In addition, a carbon cold trap is used at the coldest stage to remove condensable gases from the high-pressure gas stream. The piping assembly cools the gas within the range of 45-60 K, which, along with mass flow, establishes the cooling power. The pre-cooling stages are identical in function to the flight except for the spatial distribution of the PC3 pre-cooler. To distribute the heat removed from the gas stream at this pre-cooler three distributed stages will be implemented in the flight model two were used in the EBB. Each EBB pre-cooler is instrumented with a PRT while the flight pre-coolers will use Cernox thermometry.

An additional difference in the EBB piping assembly is the length of the counter-flow heat exchanger. This length is of importance because pressure drop along the low-pressure return will increase the temperature at the instrument heat exchangers. Table 3 lists the lengths of the two piping assemblies.

Piping Section	Thermal Boundaries	Length EBB (m)	Length Flight (m)
Compressor – PC1	280-160 K	1.5	1.4
PC1 – PC2	160-115 K	1.5	1.2
PC2 – PC3	115 K- 60 K	3	1.6

Table 3. Piping length comparison

The largest contribution in this pressure drop is in the section between the PC1 and the compressor. The pressure drop is easily calculable and was done in the EBB to 5 %. In addition, the tubing lengths are longer in the EBB configuration, hence the flight cooler will have smaller pressure drops and, consequently, lower cold end temperature than the EBB.

The final tested EBB cold end is shown in Figure 3. It is functionally identical to the flight unit in all respects. It consists of another length of tube-in-tube (not depicted in Figure 3) counter-flow heat exchanger (PC4), particle filter (PF), JT expander, liquid vapor heat exchangers 1 & 2. LVHX1 and LVHX2 attach to the HFI and LFI instruments respectively. Control of the liquid interface was performed in various configurations.

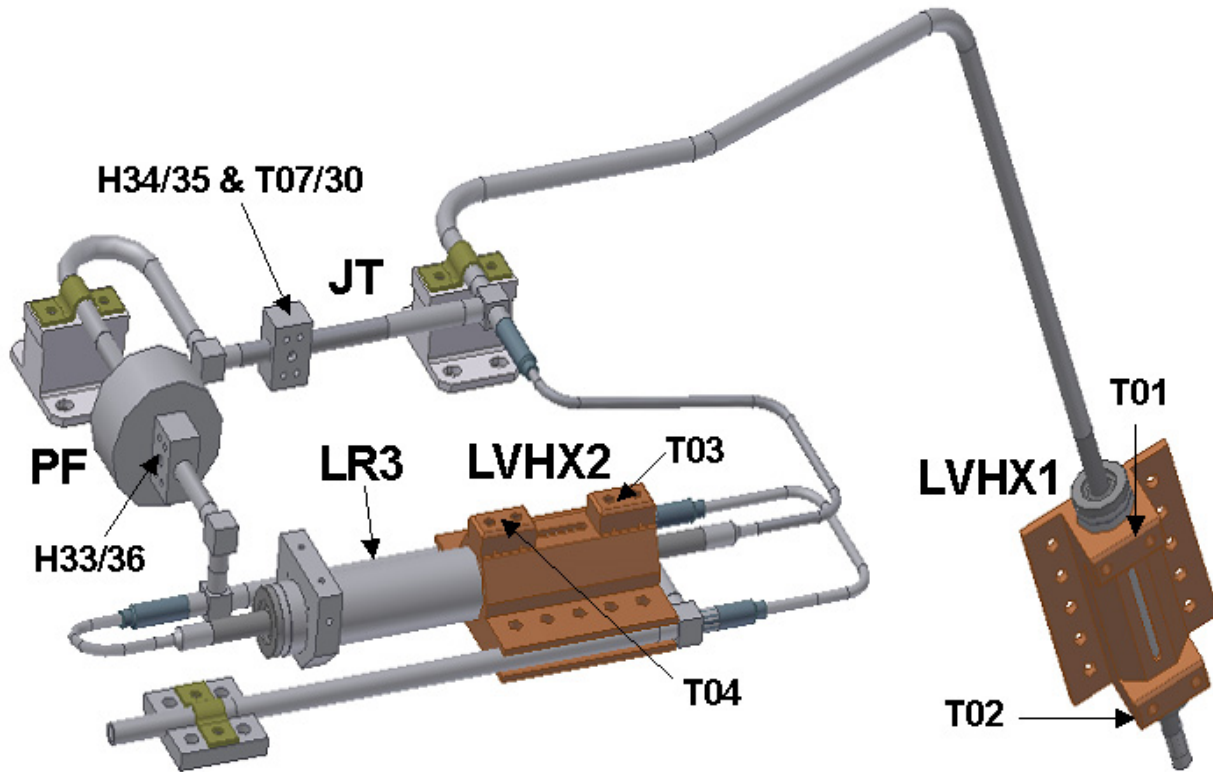

Figure 3. Pathfinder cold end model

The cold end sensors and heaters are shown in Figure 3. Redundant temperature sensors are located on LVHX1, LVHX2, LR3, and the JT flow restrictor; redundant heaters are mounted on LR3, the particle filter, and the JT restrictor. In addition to these sensors and heaters, additional heaters are added to LVHX1 and LVHX2. These heaters simulate the heat loads from the HFI and LFI instruments. A four-wire measurement is used to give a precise indication of the power applied at these locations.

Test Facility

In order to realistically test the EBB sorption cooler under flight conditions a vacuum test facility was built. This facility allows the entire cooler to be mounted in a vacuum chamber that simulates the spacecraft interfaces. A schematic of the test facility is shown in Figure 4. The chamber is relatively large, 1.5 m diameter and 3 m in length, so that the expected flight routing of the JT cryostat can be tested. During testing a vacuum of $<10^{-6}$ Torr is maintained. To simulate the warm spacecraft radiator, each compressor is mounted to a thermally isolated aluminum plate with each plate cooled by a common chiller that can reach 233 K. With this chiller we are able to produce the full thermal operational range required from Table 1. Each chiller plate is instrumented with a thermometer (PRT).

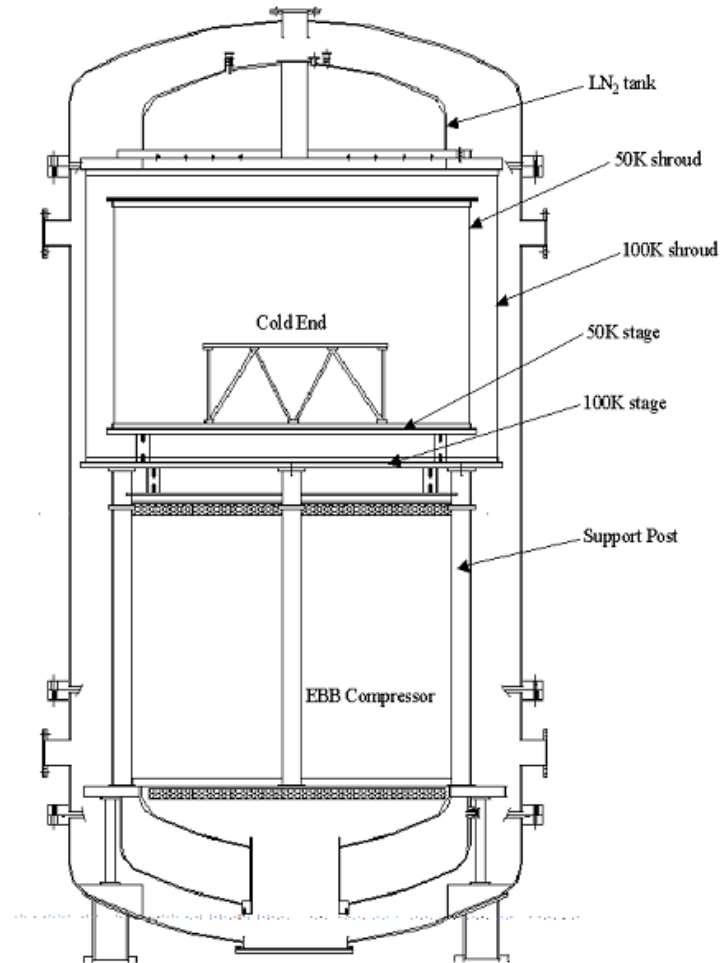

Figure 4. Planck sorption cooler test facility

Above the compressor are two shrouds that thermally isolate the cryostat from the warm compressor. Mounted on the top of the outer shroud (100 K shroud) is a 300-liter liquid nitrogen tank. The tank serves as the cooling source for the 115 and 160 K pre-coolers in addition to cooling the shroud. For the current testing the first two pre-coolers operated at 160 K and 130 K due to inadequate cooling from the test facility. The effect of this is to add an additional amount of heat that must be removed by the 50 K pre-cooler, but does not affect the cooler performance. The inner shroud (50 K shroud) is cooled by the first stage of a CTI 1020 GM cryocooler to ~50 K while the second stage is attached to the 50 K pre-cooler. In our testing we were able to maintain the 50 K pre-cooler over its entire operational range. The components below the 50 K pre-cooler (JT expander and L-V heat exchangers) are thermally isolated using Kevlar thread within the 50 K shroud to a parasitic level of about 25-50 mW. Mounted to each LVHX is a 180Ω heater to simulate the instrument heat loads. A four-wire measurement is made to determine the input power.

Comparison Between Test and Flight Interfaces

The sorption cooler performance is mainly determined by two thermal interfaces: 1) The interface of the compressor elements to its heat sink and 2) The temperature of the last pre-cooling stage, PC3. A comparison of the test and flight interfaces is given below.

Compressor/Warm Radiator Interface

In flight the six compressor elements will be attached to a common radiator that would be prohibitively expensive to simulate. The main concern for this interface is the thermal cross coupling as heat is deposited into the warm radiator. In the EBB test configuration each compressor element is attached to thermally isolated aluminum plates and this cross coupling is not simulated. However, modeling has been performed on the effect of the coupled radiator and is found to be within the margin of the fluctuation requirements. In addition, during the EBB testing the temperatures of the chiller plates were observed to begin at 4-5 K, 3 K, and 1K above the nominal chiller plate temperature during the first, second, and third absorption cycles respectively. This behavior is shown in Figure 5. These are greater than the expected fluctuations of the flight radiator, and the observed fluctuations are consistent with performance modeling of the cooler.

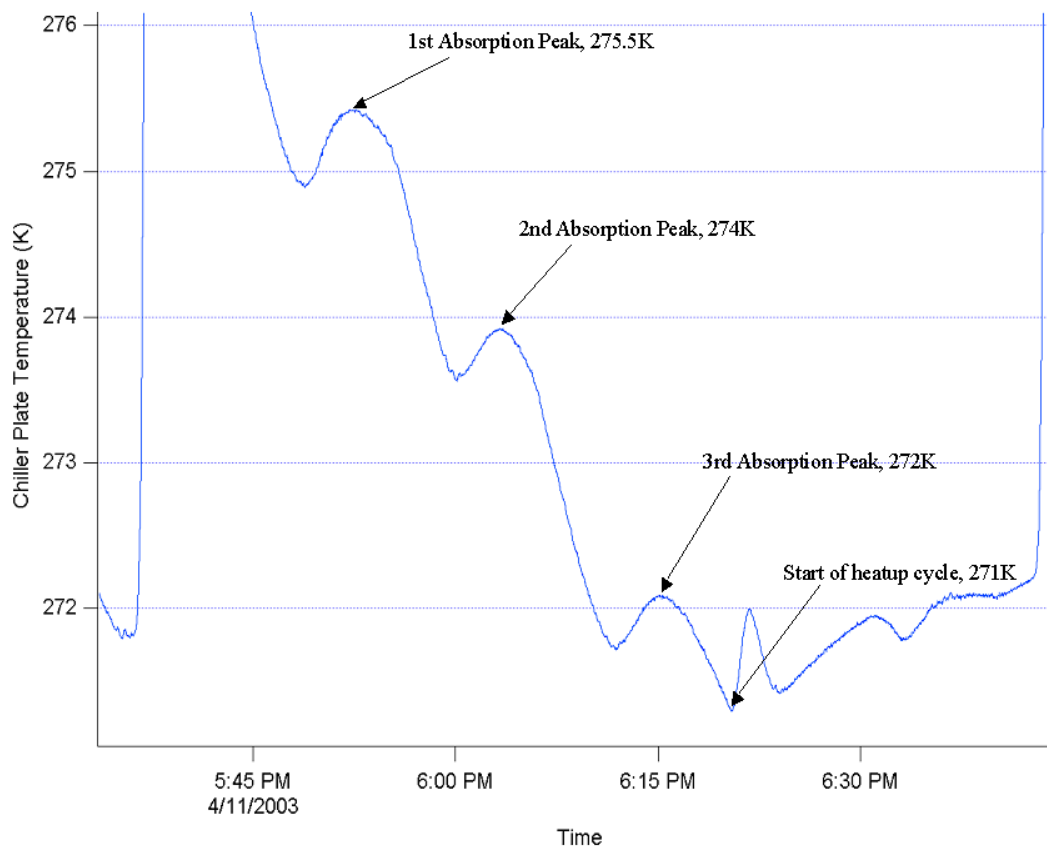

Figure 5. Typical chiller plate fluctuations during absorption.

Pre-cooler interfaces

The 115K and 155K interfaces do not impact cooler performance in that they only increase/decrease the heat load in the PC3 pre-cooler (45-60K). Because cooler performance is not impacted, they were not controlled. The heat transferred through these interfaces is easily calculated assuming certain interface behavior.

EBB Cooler Testing

Test History

EBB testing began in January, 2002, and continued through May 2003. A basic timeline of the testing history is outlined in Table 4.

Testing Period	Tasks Performed and Comments
1/10/02 – 1/17/02	Preliminary EBB testing commences. First instance of liquid hydrogen production. Preliminary testing continues until LPSB valve sticks closed.
3/5/02 – 4/15/02	More preliminary testing. First implementation of autonomous pressurization procedure. Several JT plug events occur and are cleared with a manual defrost procedure. Testing stopped to do contamination study and hydrogen recharge.
6/6/02 – 6/16/02	Continue testing of EBB cooler with fresh hydrogen charge. Development of tuning procedures for bed powers and gas gap timing. Further development of autonomous startup procedure and active cold end stabilization.
6/17/02 – 7/17/02	Operational range testing. Measure cooler performance throughout the operational ranges of PC3 and warm radiator.
7/18/02	Test effects of HPST tanks (compare 5 to 3)
8/19/02 – 9/4/02	More steady state operational testing
9/18/02 - 9/27/02	Preliminary testing of EBB cooler with ISN flight-like electronics. Successful execution of an autonomous startup procedure. Successful manual defrost executed in response to JT plugs.
10/7/02 – 10/28/02	Continue testing cooler with JPL EGSE. Test 6, 5, and 4-bed operation. Further development of autonomous operating modes, which include rapid pressurization, bad bed detection, and automated plug detection and removal.
10/28/02 – 11/3/02	Second testing of cooler with ISN flight-like electronics. Troubleshooting of electronics hardware and software problems.
11/5/02 – 11/15/02	Further development and refinement of cooler operational modes (CONDITIONING and NORMAL modes). Power outage and JT plug simulations.
1/27/03 – 2/7/03	Preliminary testing of EBB compressor with Pathfinder flight-like cold end. Several plugs encountered due to the lack of an inline charcoal filter. Placing an external cold charcoal filter inline with flow makes JT defrosting successful. Testing of pathfinder cold end active LR3 control.
3/22/03 – 4/30/03	Testing of EBB compressor and Pathfinder cold end with ~35sL of additional hydrogen charge. Testing of various stabilization schemes to minimize cold end fluctuations.
5/1/03 – 5/26/03	Testing of EBB compressor and Pathfinder cold end with ISN (now LPSC) flight-like electronics. LPSC electronics have implemented most current autonomous operation software. Testing of auto-defrost, bad bed detection, and rapid pressurization, cold end control.

Table 4. EBB cooler testing timeline

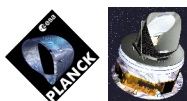

Test Results

In the following sections data will be presented on each of the four main requirements, temperature, temperature fluctuations, cooling power, and input power as a function of the warm radiator and PC3 interface behavior. Emphasis will be placed on the dependence of each requirement on cooler operating parameters, and flight interfaces. A summary table of the cooler performance over the flight allowable range of the interfaces is given in Table 5. The right-hand column reiterates the cooler requirements as listed in the TMU spec document. All data here was obtained using the pathfinder flight cold end.

Radiator Temperature (K)	260		270		280		Requirement
PC3 Temperature (K)	45.2	60	45.2	60	45.2	60	
LVHX1 Temp. (K)	17.64	17.86	17.78	18.06	18.81	18.69	<19
LVHX2 Temp. (K)	18.46	18.64	18.60	18.58	18.97	19.15	<22.5
LVHX1 I/F Fluct. (mK)*	~400	~400	~400	~400	~400	~400	<250**
LVHX2 I/F Fluct. (mK)*	~80	~80	~80	~80	~80	~80	<250***
Flow Rate (mg/s)	6.8	6.8	6.55	6.7	6.8	6.7	-
HPST Pressure (bar)	49.0	49.2	46.4	48.0	48.7	48.5	-
Calculated Cooling Power (W)	2.108	1.221	1.978	1.179	2.101	1.189	-
Normalized Calculated (W)	2.057	1.208	2.057	1.208	2.057	1.208	-
Measured Cooling Power (W)	2.042	1.226	1.919	1.123	2.069	1.117	-
Normalized Measured (W)	1.945	1.161	1.943	1.100	1.976	1.085	>0.986
Deviation Measured-Calculated (%)	3.1	0.4	3.0	4.7	1.5	6.0	-
Total Input Power (W)	394 + LPSB	394 + LPSB	384 + LPSB	384 + LPSB	377 + LPSB	376 + LPSB	<470

* To first order, LVHX interface fluctuations do not depend on radiator or PC3 temperatures

** JPL has submitted a waiver to HFI requesting the LVHX1 fluctuation requirement be relaxed to <450mK

*** LFI has requested to JPL that the cooler achieve <100mK fluctuations at the LVHX2 I/F

Table 5. Summary of EBB cooler test results

LVHX1 and LVHX2 Temperature

The temperature at the two instrument interfaces is due to many factors in the cooler design. First, it is mainly due to the temperature of the compressor element chiller plates, which determines the absorption pressure. The absorption pressure and pressure drop along the length of piping between the compressor and the cold end determines the vapor pressure of the LVHX's. The highest temperature in the liquid-vapor HX's will occur at the maximum flight allowable radiator temperature of 280 K, since the absorption pressure increases with radiator temperature. The amount of heat applied to the LPSB can also change the absorption pressure by effecting the hydrogen concentration in the compressor elements. This effect is relatively minor and will be discussed further when temperature fluctuations are considered. One additional factor is the heat applied to the LVHX's. The temperature difference across each L-V heat exchanger will depend on the amount of heat applied, so measurements are made with full instrument power applied. Figure 6a shows that the interface temperature requirements (see Table 5) for both LVHX's are satisfied, even with the worst-case chiller plate temperature of 280 K, which gives the highest LVHX1 and LVHX2 interface temperatures.

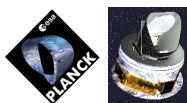

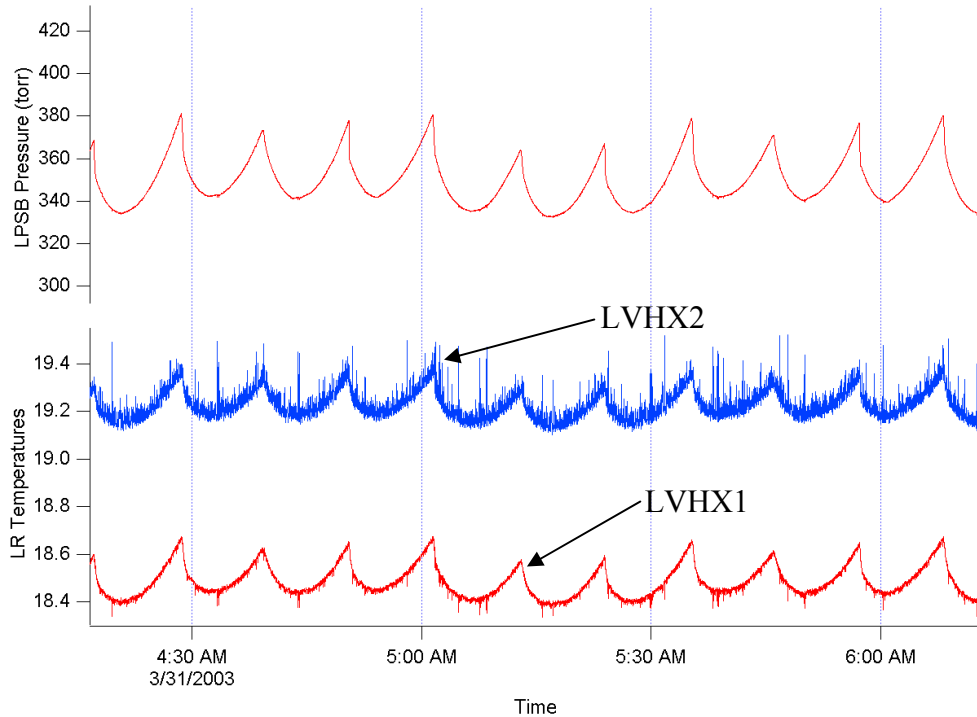

Figure 6. LVHX temperatures and LPSB pressure

Data is taken with 850 mW and 150 mW applied to LVHX1 and LVHX2 respectively. From this data, the pressure drop along the return line can be calculated. For a mass flow of 6.7 mg/s the pressure drop is ~80 Torr, corresponding to a ΔT of ~ 700 mK.

During EBB testing with the Pathfinder cold end, two geometrical configurations were tested, in order to examine the gravitational effects on LVHX performance. In both orientations, the results indicated no measurable effects with respect to the sensor resolution.

LVHX1 and LVHX2 Temperature Fluctuations

Temperature fluctuations depend principally on the absorption properties of the compressor elements. At any given time three compressor elements are absorbing and each element will absorb gas for 3 bed cycles (667 seconds). The main source of temperature fluctuation is caused by a bed beginning absorption after the cooldown cycle. This can be seen in the data presented in Figure 6, where again the LPSB pressure and LVHX temperatures are displayed. The saw-tooth behavior is due to the large drop in pressure that results when a compressor element begins absorption. Another contribution to temperature fluctuations is the hydrogen concentration of the compressor elements. Hydrogen concentration is controlled by heat applied to the LPSB. If too much power is applied to the LPSB, the compressor elements become too full, and the absorption isotherms become non-linear, with large changes in absorption pressure, resulting in large temperature fluctuations. In addition, high compressor element concentrations also result in an increase of the average LPSB pressure, in turn yielding a higher LVHX temperature. This is due to the fact that the hydride absorption pressure increases with increased concentration. By lowering the LPSB power, hydrogen is removed from the compressor elements, resulting in a decrease of both average temperature, and temperature fluctuations (see Figure 7).

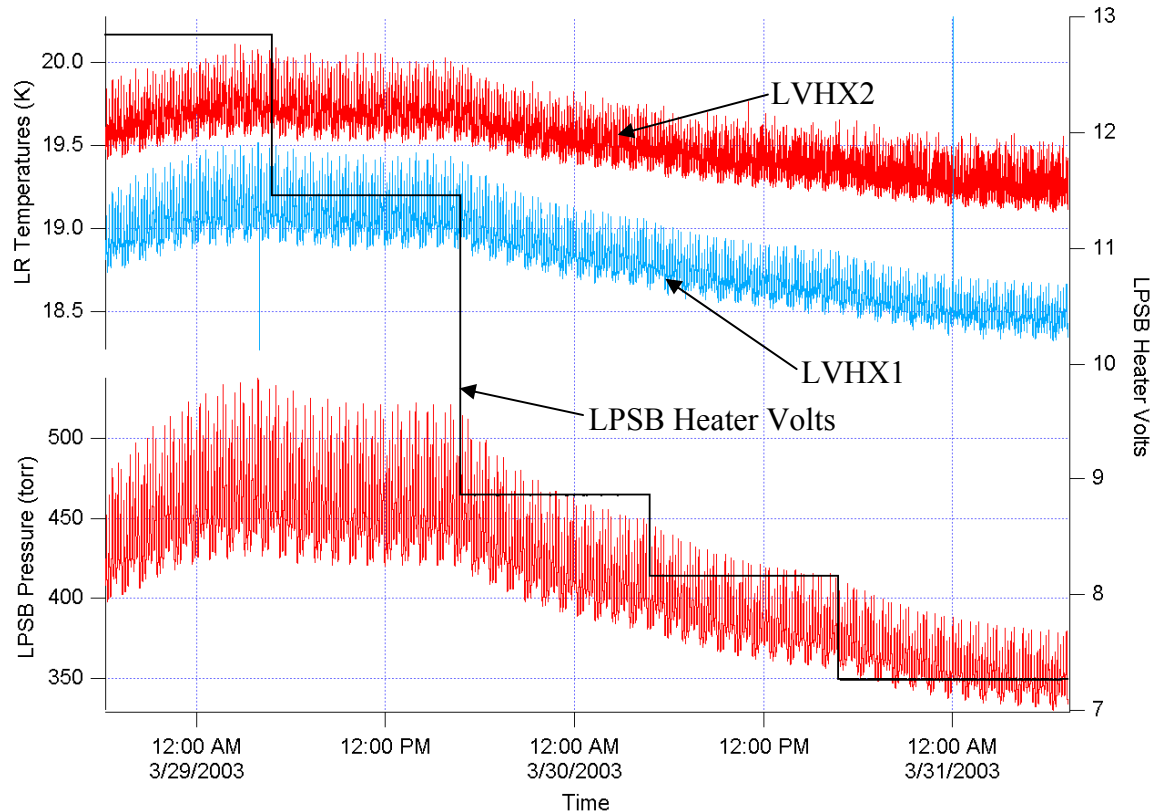

Figure 7. Dependence of LVHX temperature and fluctuations on LPSB power

According to the TMU specification, the temperature fluctuation requirements for the two LVHX interfaces are the same (<250mK). However, since the release of the TMU specification document, it was found that while HFI can accommodate higher fluctuations (~450 mK), temperature stability is a key issue for the LFI science data. For this reason, a waiver was submitted to HFI from JPL requesting the LVHX1 interface fluctuation requirement be relaxed from <250mK to <450mK. Additionally, LFI's need for lower fluctuations (<100 mK) at LVHX2 was recognized to be of primary importance by the entire Planck mission team. As can be seen in Figure 8, the fluctuations at both LVHX's are around 350mK, peak-to-peak. For LVHX1, this degree of fluctuation does not satisfy the TMU specification requirement, but does comply with the proposed relaxed requirement. From the LFI point of view, this level of oscillations exceeds the desired fluctuation amplitude by more than a factor of three.

Since the temperature of a 2-phase mixture is determined solely by its vapor pressure, the LVHX2 fluctuations can only be lowered by decreasing the absorption pressure variations. Throughout the EBB cooler test, several attempts were made to lower these variations by "tuning" the compressor. This included manipulating the gas gap heater timing, adjusting heatup and desorption bed power settings, and tuning the LPSB heater setting. Unfortunately, these procedures were unable to lower the LVHX2 fluctuations below 100mK. For this reason, an active temperature control scheme was implemented.

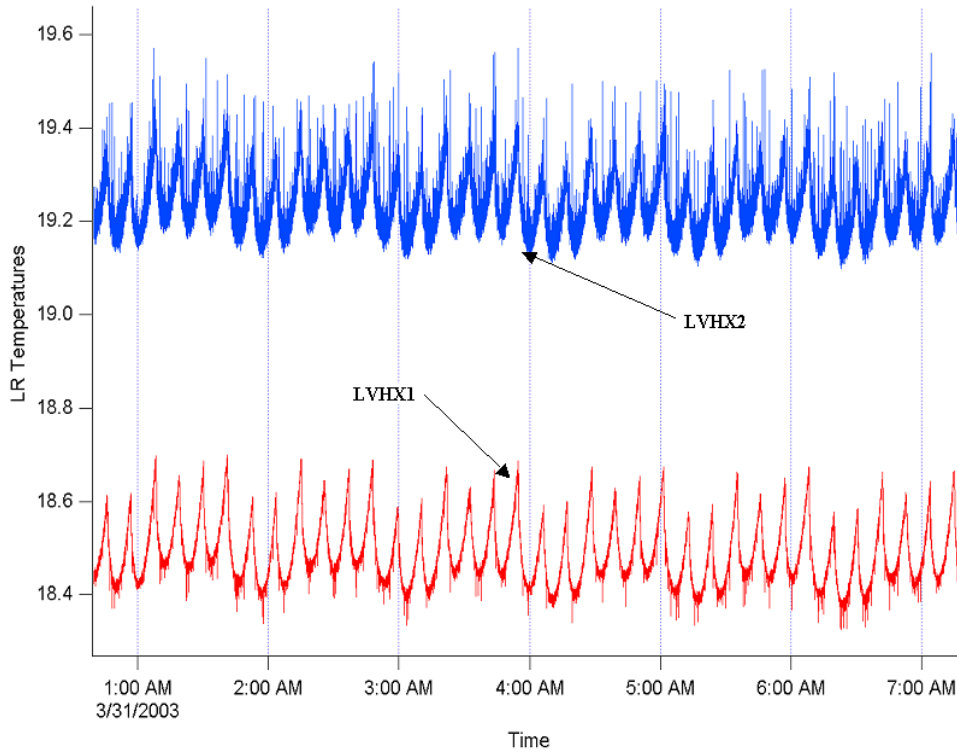

Figure 8. Liquid-vapor heat exchanger temperature fluctuations

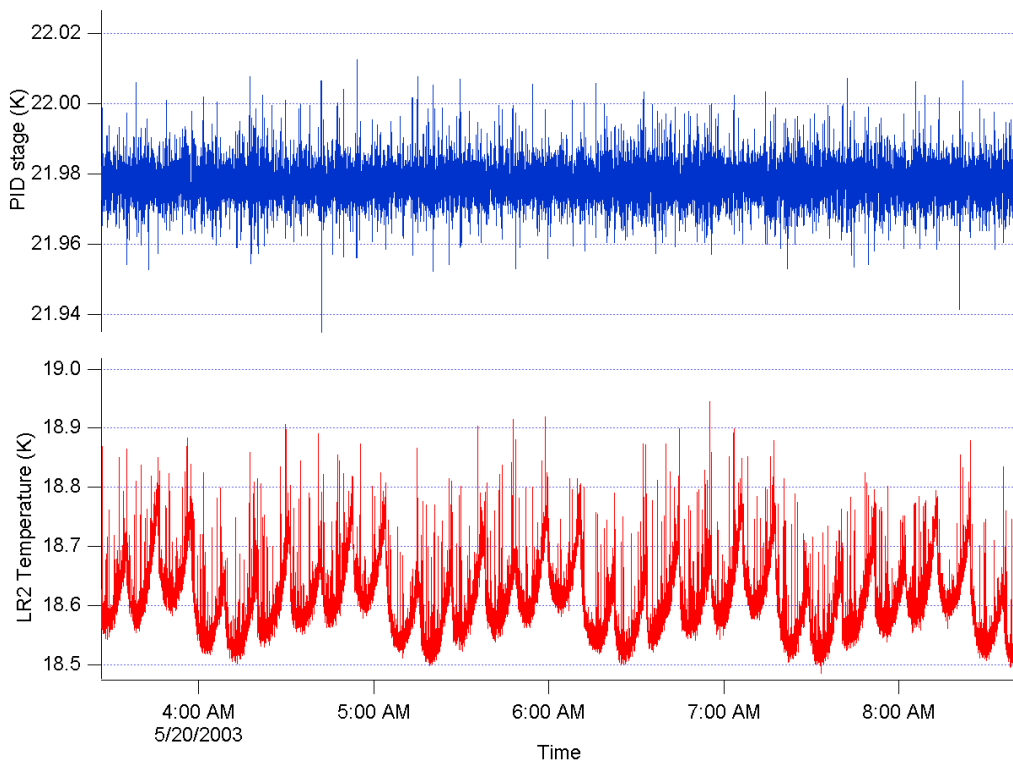

Figure 9. Comparison of controlled and uncontrolled LVHX fluctuations

Two different temperature stabilization assemblies (TSA's) were tested on the EBB cooler, both using a PID control based on the same principle. Since the thermal impedance within the LVHX is so small, a large amount of power would be required to force a change of the LVHX temperature. Consequently, the controlled stage must be decoupled from the LVHX with a carefully designed thermal impedance. This impedance must be low enough to satisfy the LVHX2 interface temperature requirement (22.5K) with the maximum LFI instrument load (865mW), and high enough to keep PID control power at an acceptable level. The two TSA designs performed similarly with respect to temperature stabilization. Figure 9 shows that the controlled stage fluctuations are maintained well within 100mK, even in the presence of higher LVHX2 oscillations. This reduces the importance of cooler tuning procedures for LVHX2.

Cooling power

Cooling power was always measured by heat balance at the cold end. This was done by PID temperature control of an intermediate section of the HX4 heat exchanger using a heater and thermometer. The set-point temperature is generally set such that the liquid-vapor interface is close to the point of control, as this has been found to provide performance advantages. However, there exists a wide range of set points over which the cold end will remain balanced. If excess cooling power exists, the liquid-vapor interface will advance up the return line. This further pre-cools the incoming high-pressure gas at the point of control, resulting in an increase of PID power to maintain the controlled temperature. The PID power will continue to increase until the liquid-vapor interface stabilizes. At this point the sum of the PID power and the instrument loads is equal to the total cooling power. Thus, the cooling power is measured by applying PID power in addition to the instrument load to the two L-V heat exchangers until the entire cold end has reached equilibrium.

In contrast to temperature, cooling power (or heat lift) is determined by the temperature of the PC3 interface (see Table 5). The cooler input power and the flow impedance of the JT expander also determine the cooling power. By design, the JT expander is chosen for a flow of 6.5 mg/s with an applied pressure of 4.8 MPa. The pathfinder JT performed very close to this design point, with a flow of 6.70mg/s at 4.8MPa. The cooling power measurements using the pathfinder JT are listed in table 5 for all interface boundary conditions. For practical reasons (see table 5), cooling power measurements were not always made under nominal flow and HPST pressure conditions. In order to compare the measured and calculated cooling powers under various conditions, the cooling power must be normalized with respect to the nominal flow and HPST pressure values (6.5mg/s and 4.8MPa, respectively). These normalized cooling power values are also included in Table 5. Figure 10 shows a plot for the worst-case PC3 temperature (60K). Early EBB testing used a JT expander that gave a flow of 5.67mg/s at a pressure of 4.8MPa [1]. In both cases, the cooling power measurements are consistent with the expected results, to within the measurement uncertainties (5%), and estimated cold end parasitics (40mW). This helps to validate both the theoretical calculations and experimental measurements of cooling power.

As discussed above, most of the time the EBB was run using 5 one-liter tanks in the HPST while the flight unit will use 4 tanks. This ballast tank reduction will increase the high-pressure fluctuations, resulting in increased cooling power variations whose only effect is to change the liquid level in the LVHX's. These level oscillations could influence the cold end temperature

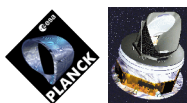

only when all liquid is being boiled off. Since by design some extra liquid is constantly present in the cold end, level fluctuations will not have any measurable effect on the cooler performance. In order to bound the “4-tanks” flight design a test was conducted wherein the number of EBB ballast tanks was reduced during operations from 5 to 3. Results of this test are shown in Figure 11, where no increases in temperature fluctuations are observed.

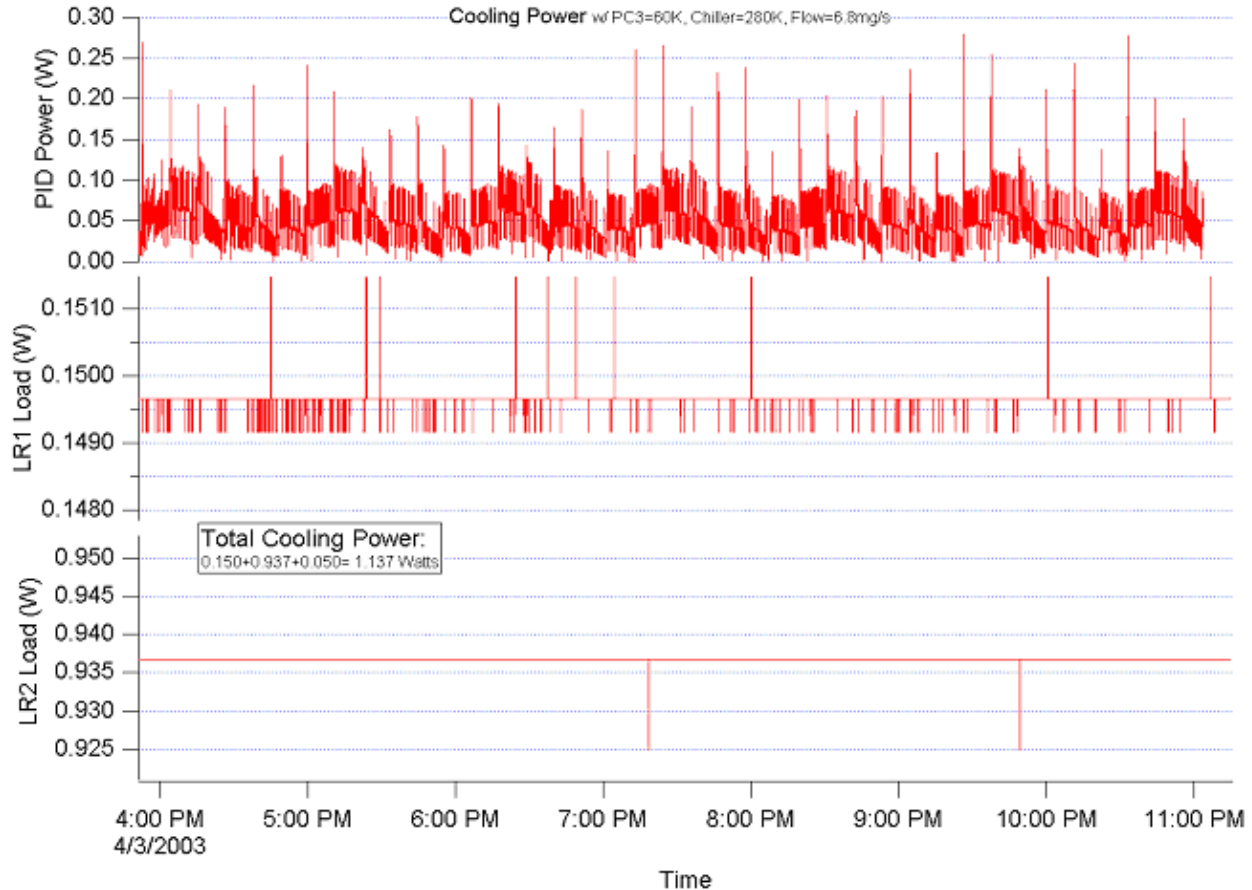
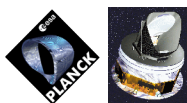

Figure 10. Cooling power data for 60K pre-cooler

Validation of Cold End performance for operational conditions

Analysis of the performance of the PACE has indicated that the heat transfer will be unaffected by the reduced gravity to be experienced under operational conditions. The results of the analyses have been reviewed at JPL, and publications detailing the designs are in preparation. Testing of the Pathfinder Cold End in various orientations relative to gravity has validated the analysis conclusions.

The Pathfinder Cold End has been operated in two configurations; one in which the output from the Joule-Thomson expander flowed in essentially a horizontal direction to and from LVHX1, and one in which the output from the Joule-Thomson expander experienced a much greater gravitational effect, both upwards and downwards, than will be the case in flight. The latter orientation was also the more severe in terms of examining effects that might affect the stability of the heat exchange with the instruments and within the Cold End itself. In all cases the two instrument heat exchangers (LVHX1 and LVHX2) were shown capable of extracting well in



excess of the specified heat loads, continuously and over the entire operational range. Further, performance tests over the entire operational range of the PSC has validated that the configuration of the counterflow heat exchanger has eliminated flash boiling as a significant source of temperature fluctuation. The results of these tests validate both the design of the instrument heat exchangers, and the analysis conclusions that the fluid flow is dominated by viscous and capillary effects in ground testing, and will be so also in flight.

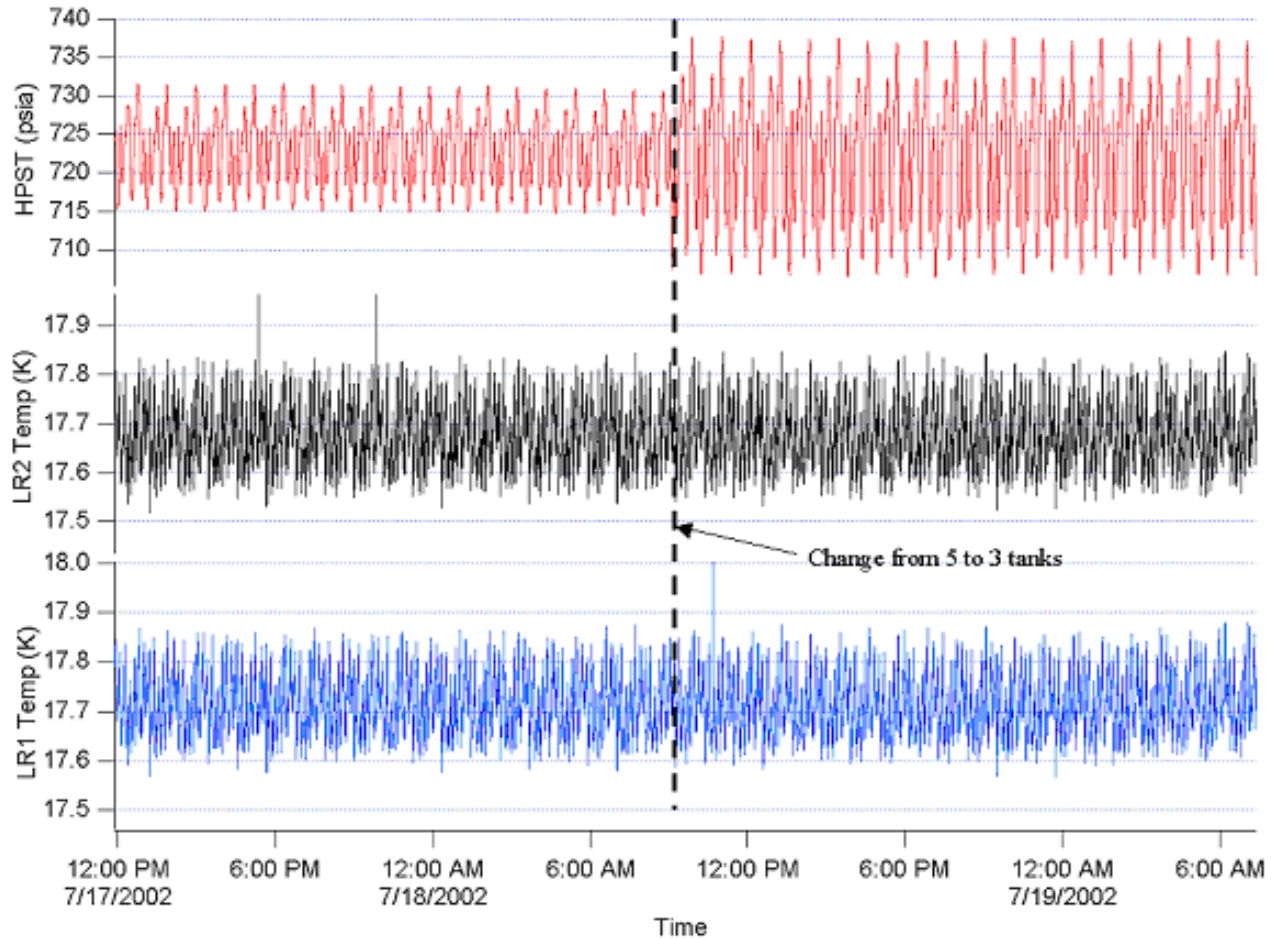

Figure 11. Effects of HPST tanks on pressure and temperature fluctuations

Input power

Total input power to the cooler is the sum of the heatup power, desorption power, LPSB power, gas-gap power, and power applied to the PID circuit of LR3. Input power is a function of the warm radiator temperature because of the increased heatup power needed to bring the compressor element to the desorption pressure in 667 s. Typically 10 W of additional power are needed for a 10 degree decrease in the warm radiator temperature. This dependence is reflected in Table 5, where the input power values needed to produce the required heat lift are reported. For all interface conditions the input power to the TMU is within the requirement.

Automatic JT plug detection and defrost procedure

One concern when operating a cooler with any JT expander is the possibility of condensable contaminants freezing in the JT, resulting in partial or full blockage of flow. The JT and particle filter are both instrumented with heaters, which can be used to heat the porous material and melt the solid contaminants. Due to the absence of a flow meter in the flight cooler design, it was necessary to devise a method of operating the cooler in such a way as to provide an indirect indication of the flow level through the JT. The logic of this calculation must be able to autonomously distinguish between actual contaminants plugs and gas flow reductions due to off-nominal boundary conditions.

During normal operating conditions, the cooler is run in NORMAL mode, which essentially cycles through the bed heating sequence strictly based on a fixed cycle time (667 seconds). If, for any reason, one or more of the cooler sensors indicate an off-nominal condition, the cooler software switches to CONDITIONING mode, which runs the cooler based on a number of operating parameters. In this mode, the cycle period is not constant, but instead is autonomously adjusted as a function of several cooler sensor measurements. When a full or partial blockage of the JT occurs, the cooler software will detect an off-nominal condition (although at first it does not know what type of condition). This will force the cooler into CONDITIONING mode. After one or two cycles in conditioning mode, the JT plug will reveal itself with a shortening of the cycle period. The CONDITIONING mode uses these short cycle times along with other cooler parameters as indicators of a plugged JT. The defrost procedure, which consists of energizing the JT and/or PF heaters, will automatically be executed.

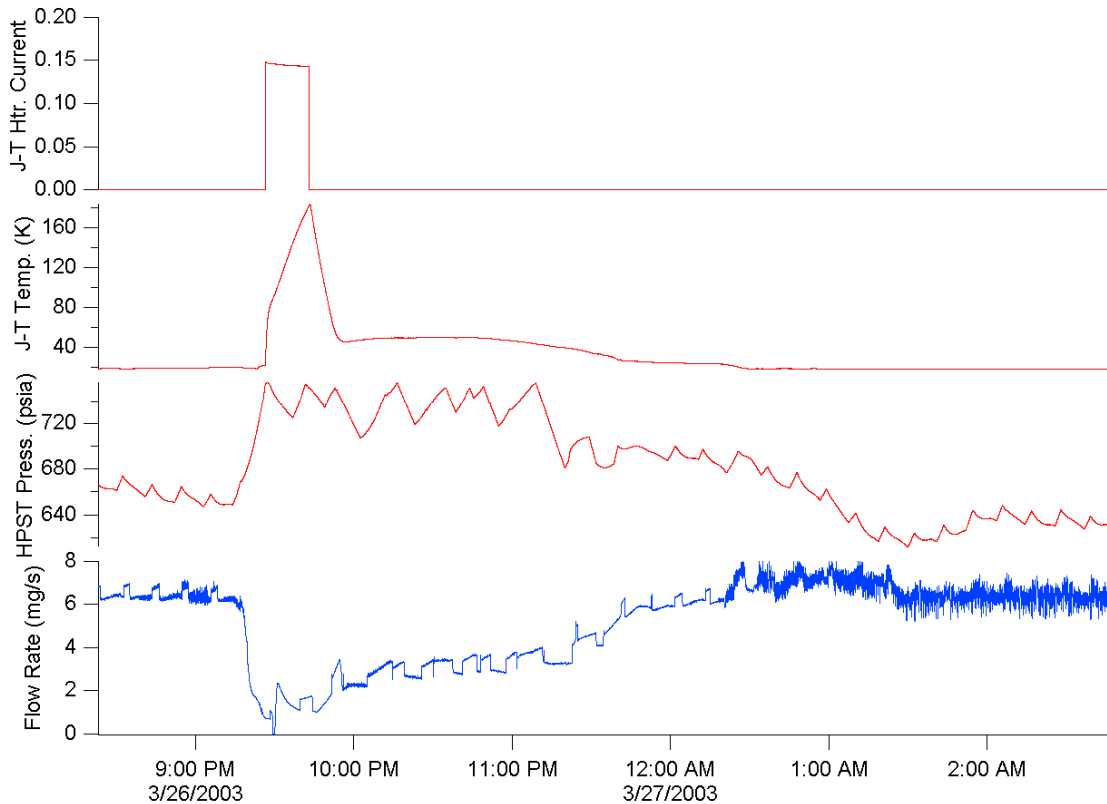
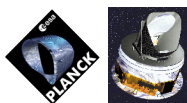

Figure 12. Successful automatic defrost of plugged JT



During EBB testing, there were occasions where the JT became fully or partially plugged. Figure 12 contains data from one of these incidents, in which the cooler software automatically detected the plug, fired the JT heater, and subsequently recovered to nominal operating conditions. This process took about 3.5 hours.

Cooler pressurization with CONDITIONING mode

One concern during the operation of the cooler is the possible loss of power provided by the spacecraft. If a power outage occurs, the absence of any further hydrogen desorption from the compressor elements will result in a rapid decrease of the HPST pressure. As the hydrogen in the stabilization tanks drains through the JT, the available cooling power will fall. Once the available cooling power falls below the instrument load and all liquid hydrogen is evaporated, the cold end temperature will begin to rise. This could result in loss of science data for as long as two weeks due to the long thermal recovery time of the instruments. Thus, it is important for the cooler to be able to recover from events such as this as quickly as possible.

The NORMAL mode of cooler operation performs nicely when all conditions are right. However, following a loss of system pressure, NORMAL mode requires a long time to build the system pressure up to the nominal level (e.g. ~4 hours to go from 500psia [34.5 bar] to 700psia [48.3 bar]). This is because the time-based NORMAL mode injects a constant amount of energy into each bed over a given cycle ($\text{Energy} = \text{Bed_Power} * 667\text{s}$). CONDITIONING mode, on the other hand, adapts the cycle period to several cooler parameters. When the system pressure is low, the resulting cycle periods become high (as long as 800 seconds), which means that more energy is injected into each bed, and more hydrogen is desorbed. This results in much faster pressurization of the system. An example of system pressurization using CONDITIONING mode is shown below in Figure 13, where the system pressure goes from 200psia [13.8 bar] to 700psia [48.3 bar] in 1.5 hours.

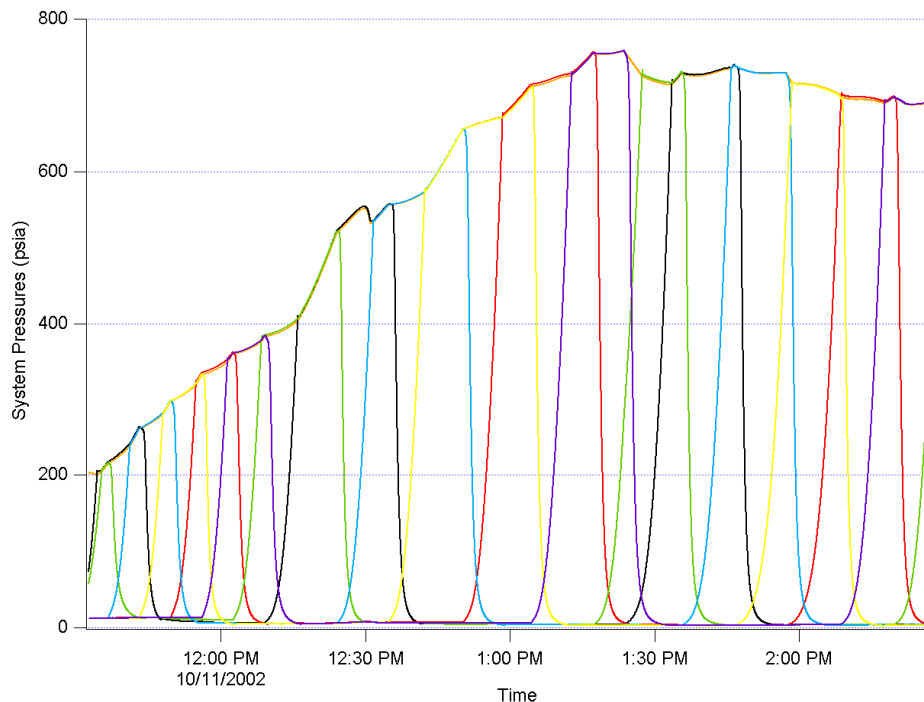
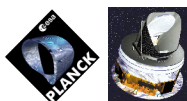

Figure 13. Cooler pressurization with CONDITIONING mode



Contamination Analysis

As discussed above, the flight design incorporates a carbon cold trap and heaters on the JT expander and particle filter for the removal of plugs. The EBB implements these same features. During the early phases of the testing, January through April 2002, several JT plugs occurred and were successfully removed by heating and the mass flow rate was recovered indicating the plugs complete removal. All of these plugs were formed during the startup phase of the cooler and never during normal operation. After this testing phase, the cooler was warmed and a contamination analysis was performed on the gas. Two methods were used to analyze the gas with both showing the presence of methane in the gas. No other condensables were observed. After the analysis all of the hydrogen gas was removed from the cooler and replaced. Cooler operation was started again and the cooler was run for about 1200 hours with no plugging. In addition, the cooler was shutdown and restarted many times during this period and no plugs were observed. As a lesson learned from the EBB tests, after the first four weeks of testing, the hydrogen gas in the flight cooler will be replaced by a fresh charge of H₂.

The presence of methane gas is expected during early cooler operations due to the presence of carbon in the welds, and hydrocarbons in residual solvents. Carbon is then catalyzed by the hydride to form methane. After the initial removal of the carbon by the gas flow methane production decreases.

In order to study the effects of a carbon trap during Pathfinder cold end testing, an external flow circuit was implemented. This allowed a carbon trap cooled with liquid nitrogen to be placed inline with the hydrogen flow. Valving permitted the trap to be bypassed. With the carbon trap excluded, a single plug event was observed during normal operation. Figure 12 shows how the autonomous recovery procedure, in response to this plug, was able to return the mass flow to its original level. A number of plugs occurred while in startup with the carbon trap removed. However, with the trap in place, no plug events were seen. The presence of a carbon trap, for this reason, is considered to be a necessity for the successful operation of the flight coolers.

Three conclusions can be drawn from the EBB cooler contamination analysis. First, it is necessary to minimize contamination level in the cooler. This can be accomplished by clean fabrication processes, and gas replacement following initial operation. Second, the use of a carbon trap aids in the removal of eventual contaminants. Finally, the automated plug recovery procedure proved to be effective in unclogging the JT in occurrence of a plug. All the above features have been incorporated in the flight cooler design and operations.

LPSC Electronics Testing

The EBB Sorption Cooler Electronics (SCE) test campaign was based on the Test Plan verification matrix previously agreed by JPL and LPSC (formerly ISN). It had a double objective:

- a) characterize the electronics hardware and software components as a subsystem, testing their compliance with cooler control and monitoring requirements;
- b) validate the Planck Sorption Cooler at system level (TMU+SC Electronics).

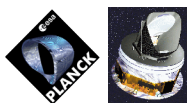

The EBB Electronics testing was carried out in three successive phases: September 2002, November 2002 and May 2003.

September 2002

This first test run had the objective of validating the primary features required to the electronic hardware and software:

- a) test the functionality of basic Operation Modes and Procedures (such as BOOT, INITIALIZATION, START-UP, NORMAL OPERATIONS, SHUTDOWN);
- b) check the cooler monitoring in terms of scan rate (1 Hz), sensors resolution and accuracy, status display and data storage;
- c) check the fixed and adjustable power provided to the different TMU heaters during operations;
- d) test the system safety and robustness through its response to failure modes detected by sensor scanning;
- e) check the functionality of system updating by uplink table.

The results of this first test were satisfying. The SCE was able to control and operate the cooler in all tested modes and procedures, according to the operational requirements. Cooler operations and cycle ran smoothly: no differences were noticed respect to JPL EGSE Ops.

Problems were found in the SCE cooler monitoring: 4 wires thermometers and pressure transducers instabilities correlated to the 20 A line activation were noticed. Some temperature sensors did not comply with the resolution requirements and all 4 wires thermometers indicated insufficient accuracy. Pressure sensors accuracy and resolution correlated well within specifications. Data scan rate was 5 times slower than required (about 0.2 Hz): this problem had a strong impact on LR3 active control, seriously degrading the control stability. Only minor inaccuracies were noticed in data display and archiving. Failure modes response fully satisfied the safety requirements. The SCE input power control resulted correct even if minor oscillations were observed. Procedures to modify and uplink the parameter tables and software patches proved to be simple, fast and functional.

For a more detailed analysis of these results see Planck EBB SC Electronics Coupled Test Report prepared by JPL [2].

November 2002

A second test phase was performed: its objective was to check all the modifications made to fix the faults detected during the first test. Basically, all the above listed problems were solved except for the 4 wire temperature sensors offset and the LR3 control instability. For the thermometers inaccuracy two possible sources of errors were identified: an insufficient calibration and the high capacitance of the long cables used for connecting the EBB SCE to the TMU via the Test Facility.

A detailed report of this second phase was prepared and circulated by LPSC [3].

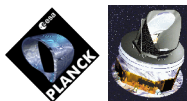

May 2003

The experience gained in the first stages of EBB TMU testing led to a deep revision of the cooler operations. The new Operation Modes structure was conveyed to LPSC in order to implement the requested modifications. For this reason, a new test phase was planned at the end of EBB testing.

All new operation procedures and states were tested with extremely good results. The cooler performance in terms of startup process, defrost response and normal operation was satisfying and no differences with JPL EGSE operations were found.

In this last phase of tests the offset due to the cables capacitance was still detected, degrading the measurements accuracy. The resolution of the cold end temperature sensors was improved and the sensors scan rate was increased to the required level: as a consequence, the LR3 PID control was finally refined and settled.

Conclusions

EBB testing gave us the opportunity of validating the design principles derived from the flight requirements. The experience provided by the 12 months of EBB operations suggested strategies and solutions to further improve the performance of the cooler in several aspects, with the Operation logic efficiency and the Cold End Temperature stability being just two out of a numerous number of such solutions.

The results obtained in the test campaign gave us an extraordinary insight in operation of the sorption cooler, confirming the predictions and analysis, and validating the flight design.

All the lessons learned during the EBB tests have been included in the design and operation of the flight cooler. In addition, the EBB test validated the basic functionality of the test facility. The facility will remain essentially the same for the flight cooler testing, except for modifications required to accommodate the geometric configuration of the flight cooler.

The enormous experience gained from the extensive EBB testing campaign greatly improved the reliability, robustness, and ability of the flight cooler to meet its requirements during testing and during flight.

References

1. Pearson D., Borders J., Prina M., Morgante G., Bhandari P., Bowman R., Loc A., Planck Engineering Breadboard Sorption Cooler Test Results Over Its Entire Operating Range, *Proc. Of 19th ICEC, Grenoble, France, 2002*
2. Planck EBB SC Electronics Coupled Test Report, JPL Document
3. Planck Sorption Cooler Electronics EBB Coupled Tests Report, HFI Document:RP-PSCB410-1000xx-ISN

