



Publication Year	2016
Acceptance in OA	2020-07-22T10:33:58Z
Title	Towards the cryogenic sliding mechanism for MOONS-ESO
Authors	TOZZI, Andrea, CARBONARO, LUCA, OLIVA, Ernesto, Iuzzolino, M., Strachan, J., Rees, P.
Publisher's version (DOI)	10.1117/12.2231906
Handle	http://hdl.handle.net/20.500.12386/26571
Serie	PROCEEDINGS OF SPIE
Volume	9908

PROCEEDINGS OF SPIE

[SPIDigitalLibrary.org/conference-proceedings-of-spie](https://spiedigitallibrary.org/conference-proceedings-of-spie)

Towards the cryogenic sliding mechanism for MOONS-ESO

Tozzi, A., Carbonaro, L., Oliva, T., Iuzzolino, M., Strachan, J., et al.

A. Tozzi, L. Carbonaro, T. Oliva, M. Iuzzolino, J. Strachan, P. Rees II, "Towards the cryogenic sliding mechanism for MOONS-ESO," Proc. SPIE 9908, Ground-based and Airborne Instrumentation for Astronomy VI, 99087Z (9 August 2016); doi: 10.1117/12.2231906

SPIE.

Event: SPIE Astronomical Telescopes + Instrumentation, 2016, Edinburgh, United Kingdom

Towards the cryogenic sliding mechanism for MOONS-ESO

A. Tozzi^{a*}, L. Carbonaro^a, T. Oliva^a, M. Iuzzolino^a, J. Strachan^b, P. Rees^b

^a INAF-Osservatorio Astrofisico di Arcetri, Largo E. Fermi 5, 50125, Firenze, Italy

^b STFC, Polaris House, North Star Avenue, Swindon, SN2 1S, U.K.

Abstract

The Multi-Object Optical and Near-Infrared Spectrograph (MOONS) shall be installed at one of the Very Large Telescopes (VLT) at the European Southern Observatory (ESO) in Paranal Chile. The instrument is being designed and built by an international consortium on behalf of ESO. The design is based on a three arms configuration, RI, YJ and H band, where RI and H have two possible resolutions. To achieve this goal it will be necessary to implement a sliding mechanism changing the dispersers, the filters and the cross dispersion prisms. This article describes the cryogenic exchanger mechanism that is under realization and the preliminary mechanical and optical tests that we have done at the cryogenic facility of Arcetri observatory of Florence. Parts of these test are based on interferometric measurements of the optics to study the behavior of the mechanical supporting structure, and part are based on the cryogenic sliding system that will be used to move approximately 200 Kg of mass for 350 mm of travel range. The cryogenic sliding system, rails, screws, motors, is based on commercial components as the position measurement device that is based on commercial potentiometers. The results of the tests and performances at cryogenic temperature are reported in this paper.

Keywords: MOONS-ESO, high resolution spectrograph, cryogenic movement.

1. Introduction

This article describes the mechanical design of the cryogenic mechanism used in MOONS spectrograph to change the disperser elements from high to low spectral resolution. This system is the preliminary one, used for tests at cryogenic temperature not using the final optics but a dummy lead weight. This tests have been done using the cryogenic facility realized in INAF-Osservatorio Astrofisico di Arcetri (INAF-OA), in Florence.

2. General description

In Fig. 1 MOONS optics are shown for the two optical configurations: high resolution and low resolution for the three optical branches. In really only H and RI has a double resolution modality: for these two branches the dispersing elements are interchangeable. This article describes the mechanics and the test done on this structure.

*First Author, E-mail: atozzi@arcetri.astro.it

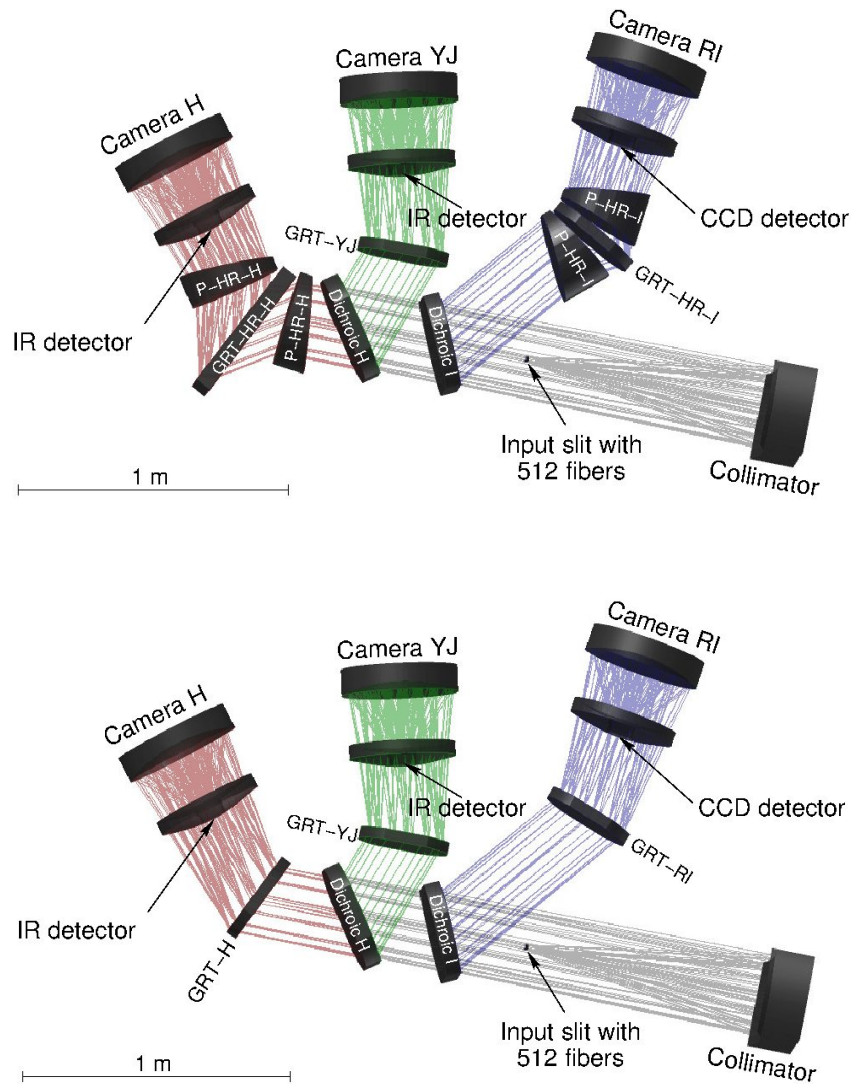

Fig. 1 Top: high resolution optics configuration of MOONS. **Bottom:** low resolution optics.

In Fig. 2 the conceptual scheme for there H and RI systems is shown. They are paired two by two by a mechanic connection that is needed to transmit the movement avoiding the necessity to use four cryogenic motors: we have dimensioned the motors to control the movement of the total mass of the two twins systems.

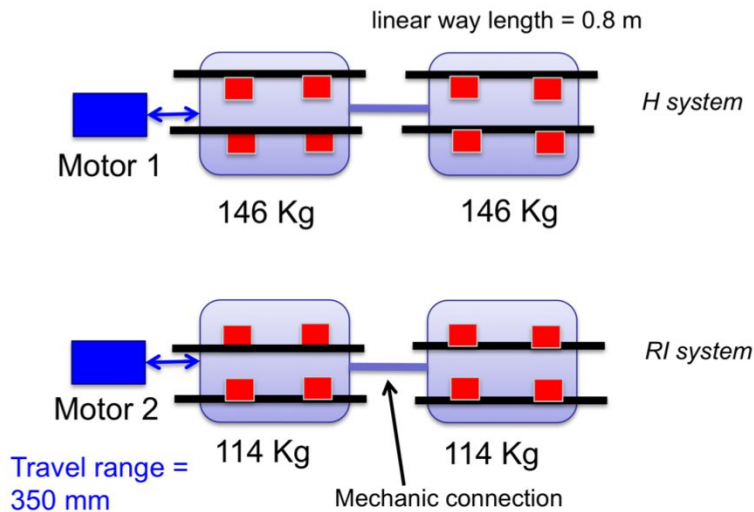

Fig. 2 Schematic view of the whole system. In red the slides.
In blu the two motors and in black the rails. Weights are gravity invariant.

3. Inventor preliminary design.

The optical tolerances are not so challenging, so we have used a mechanical retaining system philosophy based on fixed points and not on an auto-centering one.

For the positioning of the optics with respect their nominal position we have used for each device in force of INAF-OA the same philosophy already used in previous cryogenic spectrographs like GIANO-TNG in which six hard point are realized in the aluminum mechanical frame itself: these points are machined by the same piece of aluminum previously thermally stressed (at least three cycles $300\text{K} \rightarrow 100\text{K}$), finally machined and tested using a coordinate-measuring machine (CMM), like model Zeiss MMZ-G used for GIANO-TNG cryogenic optical bench, that can fit mechanic components with meters of dimension and measuring absolute positions with a resolution of 1 micron.

In the following pictures the preliminary design of the support structures for the optics are shown.

Some of these mechanical components are fixed with respect the optical bench (in pink): Filters RI-YJ, dichroics RI-H, VPH IJ, collimating Mirror. Others are movable: VPH H, VPH RI.

The Optical Bench used in this preliminary design has mainly a rectangular shape, having the following dimension: 3.2 m x 2.2 m with a chamfer on the top edge.

The travel range of the two linear stages is 350 mm. Maximum encumbrance of the full structure is 2034 mm and is represented by the movable part of the H disperser.

The distance between the cryogenic optical bench (in pink) and the pseudo chief ray of MOONS is assumed to be 340 mm at room temperature.

In this design each optical element is kept in its nominal position using a six axis retaining system based on dynamic forces: linear springs are used to press the optics onto six fixed, hard points. The total elastic forces along X/Y/Z directions are equal or larger than the 3 times the weight of the optical element. Particular care will be dedicated to the design of the contact points to minimize deformation of surfaces.

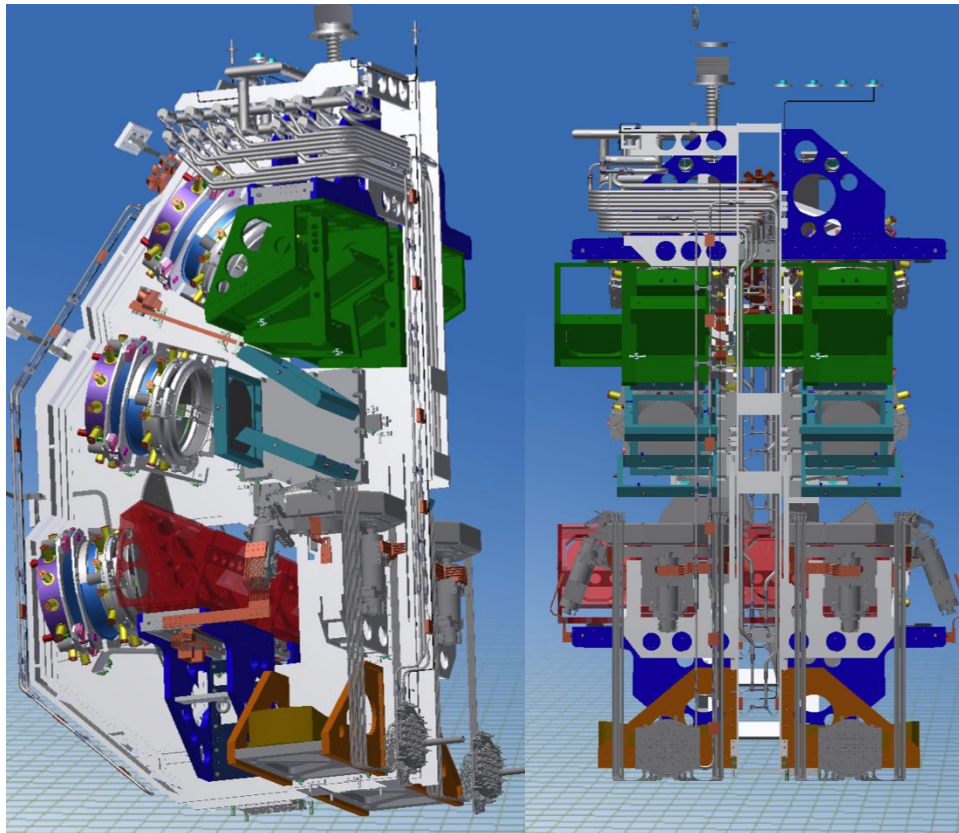

Fig. 3 MOONS spectrograph design. Total height is 3.2 m. In green the H arm and in red the RI arm: these two arms have two spectroscopic modalities, low and high resolution, changeable.

4. Sliding system for the VPHs and optics.

The moving parts of the H and R grating exchange mechanisms are based on the same principle: they are taken in position using commercial rails, motors and ball screws components suitable for vacuum environments and cryogenic temperatures. Each mechanism includes two commercial linear-rails (model LWL25 by IKO) and one stepper motor (Phyton VSS57) with built-in 1:16 gear box reduction; similar motors were extensively used at INAF- Arcetri in the recent past. The movement is transmitted using a 400 mm dry ball-screw (Kuroda model FE). In Fig. 3 the schema of the whole exchange mechanism and in Fig. 4 one of the two exchange mechanism in details: two potentiometers and the motor resolver give information about the position of the system. One single motor controls the positioning of the optics.

Two linear slides are mounted on each rail i.e. the structures carrying the gratings are mounted onto four slides. The rails and slides are hugely oversized in terms of loading rate, but are probably necessary to handle torsion moments during shipping or earthquakes. Part list is described in a following section, where are listed the devices we have bought for the cryogenic test in Arcetri laboratory.

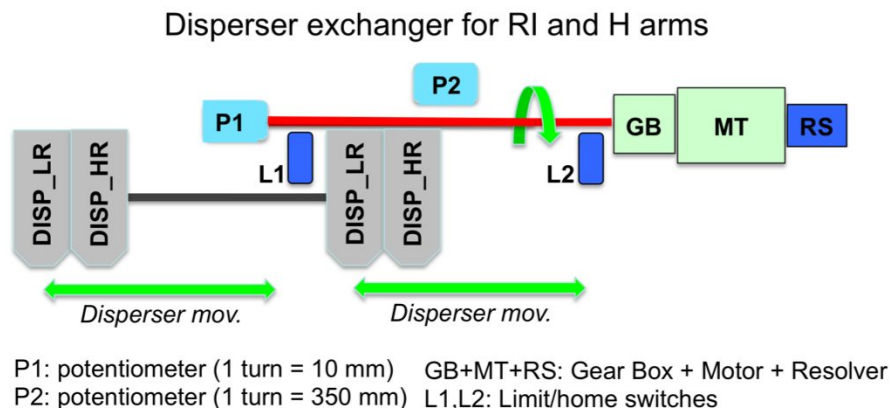

Fig. 4 Schematic view of the Exchanger mechanism for MOONS

All the moving components are in Steel alloy. The first rail, the first slide, the ball-screw and the motor are mounted onto a support structure of the same material. The first slide and the

remaining steel elements (the second rail and the other 3 slides) are mounted onto the aluminum structure using a combination of fixed joints and compression springs to compensate for the

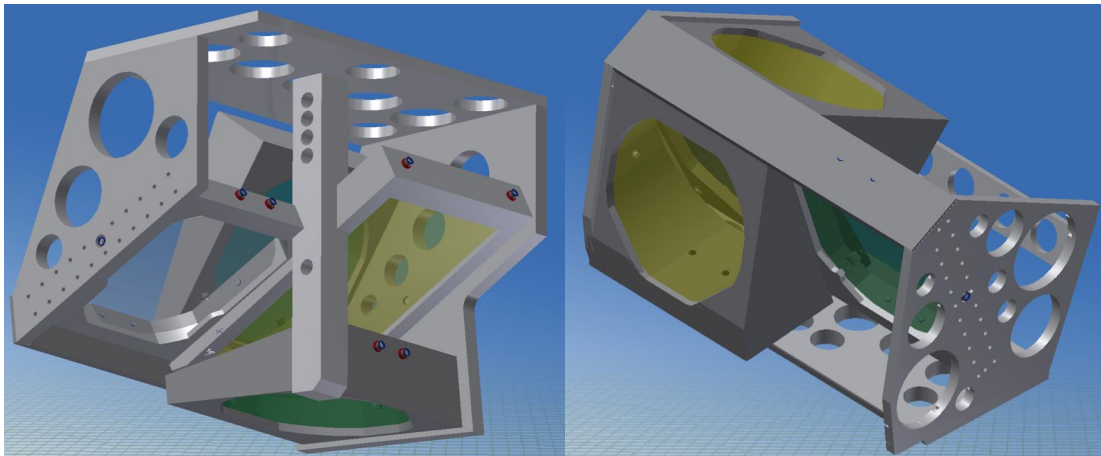

Fig. 5 3D mechanical design of the disperser mechanisms: in figure are represented the movable parts. On the left the H arm, on the right the R one.

difference of thermal expansion coefficients. The CTE compensation is particularly important in the direction along the rail, whose relative length increases by more than 1 mm at cryogenic temperatures. The slides are fixed on the bottom and top aluminum plate of the movable support for the R and H optics respectively: this is not a problem for the IKO slides, that are based on a four points contact philosophy. In Fig. 5 the two movable parts of the dispersers are shown: on the left the H channel and on the right the R one. Their masses values are reported in Table 1.

5. System reliability

System reliability is related mainly to the Mean Time Between Failure of the Phytron motor that is $20 \cdot 10^6$ revolutions. Taking into account that the travel range is 350 mm, the pitch is 10 mm, the gear-box ratio is 16, we obtain around 450 revolution for single usage and a number of cycles before failure of 44600. If the exchange mechanism is used four times for single observing night, we have 11100 continuous working nights.

6. System performances

In the following some preliminary results of the system performances are reported.

a. Dynamic mechanical performances

A preliminary study to analyze the first eigenfrequency of the assembly have been done for PDR. This is needed for the overall earthquake analysis: the frequency value seems to be located over 100 Hz: this value is strictly related to the K value of the six springs used for the retaining system of every optical component. These springs generates a force that presses the optic over an hard point located in the opposite side with respect the spring itself. These springs have a calculated preload force that is at least three times the weight of the optics: this implies that the interfaces works as a pin and nota as a spring. So doing the whole system dynamically works as a single rigid body, reaching a first eigenfrequency value over 100 Hz. Deformations of the optics are negligible for a contact surface dimension of approximately 1 cm²: we estimate to have deformations below 20 nm on the whole clear aperture, a value that doesn't have effect on the final PSF.

b. Alignment performances

On this collimated beam the optics in charge if INAF (VPH, dichroics, filters) will be aligned. The requested alignment of such devices is not critical: for the VPH the requested value is around 0.5 mm of decenter (X,Y,Z axis) and 3 arcmin of tilt. These values can be easily guaranteed not only for the fixed optics of but also for the movable optics of Fig. 5.

7. Dimension and mass

In Fig. 3 the whole system, and in Fig. 5 the two dispersers: the distance between the two optical axis, high and low resolution, is 350 mm and the mechanical encumbrance is symmetric with respect these two axis.

In the following table (Table 1) the mass of the mechanical support structure, as actually designed as solid components mainly made in aluminum, is reported. For each movable group of optics there are 14 Kg of Iron as support for the commercial rails of 2.2 Kg each. The value reported in this table are not the definitive ones: these because we are studying the possibility to reduce dimensions and masses of the optics, in particularly of the dispersers elements and filters.

version	item	description	Movable components mass [Kg]			Fixed components mass [Kg]			total mass for item [Kg]
			optics	supports (Alum.)	subtotal	optics	supports (Alum.)	Iron components	
V 51	1	H disperser	64	82	146				219
	2	R disperser	54	60	114				187
	3	Dichroics & filters collimator				30	64	1	95
	4					82	52	1	135
TOTAL [Kg]=								635	

Table 1 Mass of the INAF-OA components. In grey the aluminum, in blue the optics and in orange iron components

8. Preliminary part list

For the cryogenic movements we have decided to use commercial components not only for the motor as usual, but for the rails, ballscrews and slides, too. The risk related to the use of commercial components has been mitigated testing them before the final design. In accordance with our specification document IKO engineers have selected the following motor model:

Overall system parameters:

- ball screw pitch: 10mm
- ball screw diameter: 12mm
- spindle efficiency: 50%
- spindle preload bearings: 100N
- speed: 2mm/sec (350mm/180sec)
- weight to be moved horizontal 700kg, (500kg are required),
- 50% percentage of rated current
- Gear efficiency 50%, (normal 75 to 85%)
- Gear shaft rotations: 12 rpm (350mm/10mm/180*60=11,66rpm)
- Motor rotations: 186 rpm.

•Motor Type: Phytron VSS57.200.2,5GPL-UHV-CHYR-RS1,5: EXTREME ENVIRONMENT STEPPER MOTORS In Vacuum 2 phase hybrid stepper motor. (code 10018465):

- size 57, 200 steps, nominal current 2,5A
- 4x1.5m kapton-insulated leads, AWG 24, parallel winding, wire exit on the side
- second shaft
- solid lubrication
- high vacuum up to 10^{-11} mbar
- radiation resistance 10^6 J/Kg
- winding temperature -270 °C to 40 °C

Accessories: resolver encoder mounted on the second shaft

- Gearbox: Phytron VGPL52.2/16-S-UHV

UHVC EXTREME ENVIRONMENT GEAR BOXES Planetary gearbox (code: 10018485):

- size 52, 2 stages
- ratio $i=16:1$, low backlash
- Solid lubrication
- Ultra high vacuum up to 10^{-11} mbar
- Radiation resistance up to 10^6 J/Kg
- temperature from -270 to +40°C

- LWL20C2R800BH / BSK - IKO precision rail. Length: 800mm for UHV with two slides.
- FE1210PS-HPNR-0478x0408-C7M – Ball screw Kuroda for UHV, diameter 12mm, pitch 10mm, travel range 350mm
- Custom metal coating: dicronite for UHV environment.

Accessories for the Arcetri cryogenic test (not used in MOONS final design) by Pythron:

- TOA200 - UHV SPECIAL COMPONENTS UHV micro Switch compatible with UHV environment;
- 10m-KI, FEEDTHROUGH KAPTON INSULATED, wire 0,61mm;
- 10007555 - PHYTRON ELECTRONICS MCC-1 32-48 MINI-H-USB- Stepper motor control unit for 1 axis, Phase currents up to 3,5A PEAK, Power Supply 24 to 48V DC; Step resolution

up to 1/256 Step, 8 bidirectional digital in-/outputs; Interface USB,

- G-RECLDBI-1024-5X1-24_ - LTN Converter resolver-encoder version -24: +14/+36V
- LFZV150NP24D – ELETTRONIC Power supply, desk top, CEC, 24V, 6.25A, 150W

9. Cryogenic test.

In Arcetri Observatory we have realized a cryogenic facility for testing small medium opto-mechanical systems. In Fig. 7 it is shown the proposed mechanical exchange system for MOONS assembled using a dummy weight of 160 Kg of Pb bricks.

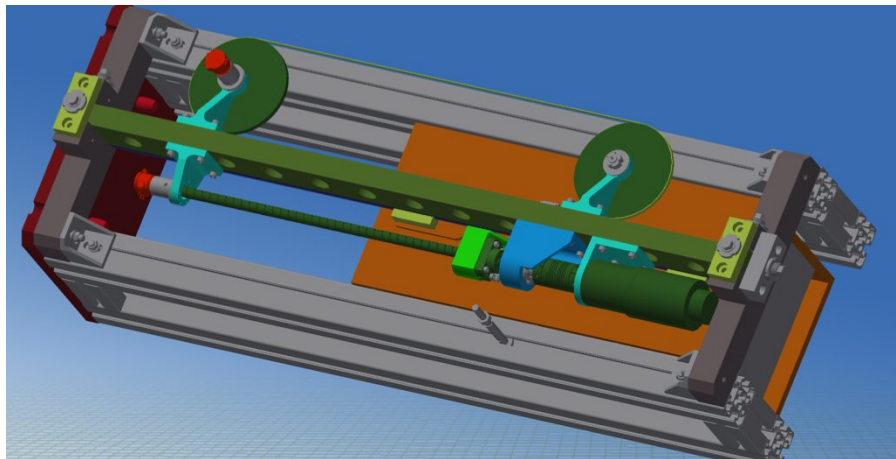

Fig. 6 3D design of the cryogenic assembly for MOOS exchange mechanism

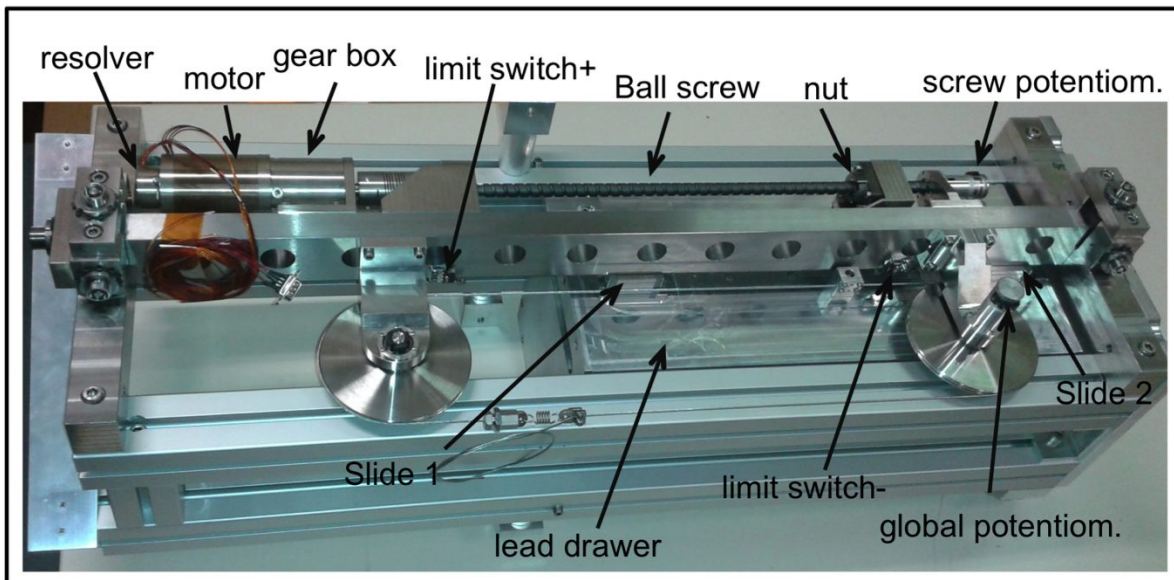

Fig. 7 The exchange mechanism of MOONS assembled for the cryogenic test at the Arcetri observatory.

The system is identical the final one, except for the presence of the second rail, not present in this demo. This for two reasons: the first is related to the maximum dimension of the cryostat that it is not compatible with the exact replica of the MOONS one. The second is because so doing we are in a worse condition in terms of stress on the single slide.

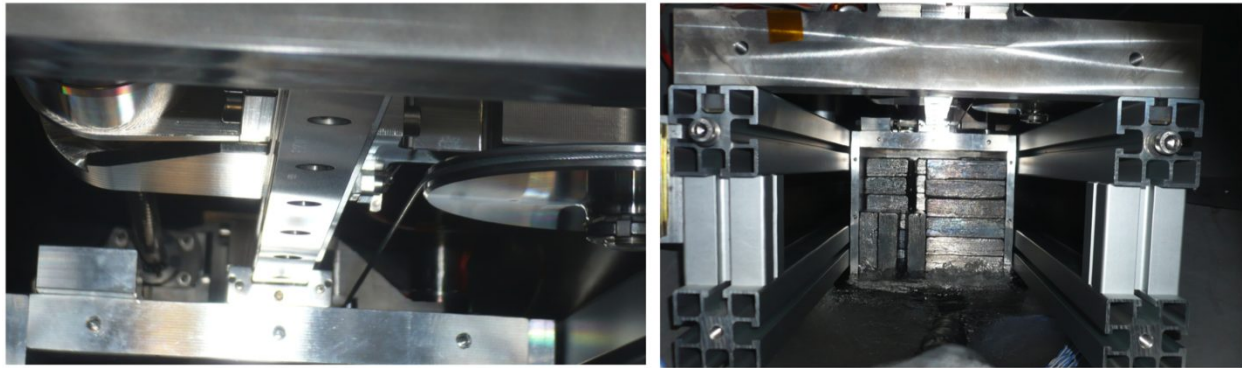

Fig. 8 The MOONS exchange mechanism into the dewar during cryogenic test. On the right the Pb bricks are visible with the boiling liquid Nitrogen just in contact with them On the left a closer view of the rail and the slides when the system was at a temperature of about 120 K.

We have extensively tested the exchange mechanism before at room temperature and atmospheric pressure, then into a suitable cryostat closed and evacuated up to 10^{-4} mbar. No problem during any movement using 0.4 A instead of the 2.5 A nominal current. After this preliminary test we have used liquid nitrogen to cool the mechanics below the working temperature of MOONS (120 K).

Table 2 summarizes the results of these tests are reported.

No failure has been reported, except for the two linear potentiometers that, as already noticed in GIANO cryostat, work very fine but they preliminary need many tents of turns in a cryogenic environment before working. After this operation they are reliable, exceptionally precise and have a very long time life: in GIANO we have ten of these potentiometer working at 80 K since several years.

Environment conditions	293K 1 bar	293K 10^{-4} mbar	110K(bottom)-160K(top) 650mbar	110K(bottom)-160K(top) 160mbar
Current (% nominal 2.5A)	16%	16%	20%	24%
Frequency (1/4 microstep)	4KHz	4KHz	2KHz	2KHz/4KHz
Motor	passed	passed	passed	passed
Resolver	passed	passed	passed	passed
Limit switches	passed	passed	passed	passed

Table 2 Results of cryogenic test. Travel range time for 300 mm at 4KHz is 97 s, at 2KHz is 194 s. The temperature has been read using two PT100 sensors one placed on the fixed iron bar (top) and one on the movable drawer, just near one of the two slides (bottom). Dummy weight during tests is 160 Kg.

The system has been cooled using direct feeding of liquid nitrogen directly into the cryostat avoiding the presence of air and humidity. The temperature was read using two PT100 sensors placed one on the fixed iron bar and one on the movable aluminum drawer, where 160 Kg of lead were collected. Pressure was read using a suitable sensor placed along the cryotube between the cryostat and the vacuum rotative pump.

A passed test for the motor and for the resolver means the motor was moving correctly with no loss of steps. The steps have been read using the Pythron resolver and the two linear potentiometers:

- The resolution of the resolver is 5.12 counts for a single microstep (equal to 1/4 of motor step, the value used during all the test), so it is 1.28 counts/steps or 4096 counts for a single turn of the motor*.

* 5.12 counts/step is the measured value: it corresponds to $5.12 \times 4 \times 200 = 4096$ counts for a single motor turn (we used a 200 motor step working at 1/4 micro-step).

- The resolution of the two potentiometers is different. The one attached to the ball screw axis in particular has to read the same value of resistance every turn of the axis itself, that it means every 10 mm of movement of the crew, being the pitch of the screw equal to 10 mm. The potentiometer is a 10KOhm wire one, and the minimum “step” value is around 9 Ohm, This means a reading resolution of 1/1000 of turn, corresponding to 0.01 mm of linear motion.

A passed test for the limit switches means that it has changed its electric status after a homing positioning as recognized by the Pythron driver control panel.

10. Conclusions

The MOONS project has passed the PDR. In this article the cryogenic exchange mechanism is briefly described: this is one of the most challenging mechanical device of the whole system being the optics so huge and heavy. The possibility to have a double resolution spectrograph is a great opportunity for the scientific community and we have demonstrate that this exchange mechanism can work fines up to the cryogenic environment condition imposed by MOONS top level requirements.

11. References

- 1 Brunner S. et al., 2010, Proc. SPIE 7735
- 2 Cerasuolo M. et al. 2011, The Messenger, 145, 11
- 3 Cerasuolo M. et al 2014, Proc. SPIE 9147, 91470N-1
- 4 De Jong R., et al. 2012, Proc. SPIE, 8446-27
- 5 Guinouard et al. 2014, SPIE, 9151-180
- 6 Li Causi et al. 2014, SPIE, 9147-229
- 7 Oliva E., et al. 2012, Proc. SPIE, 8446-187
- 8 Oliva et al. 2014, SPIE, 9147-84
- 9 Ramsay, S.; Hammersley, P.; Pasquini, L., 2011, The Messenger, 145, 10