



Publication Year	2016
Acceptance in OA	2020-04-30T13:57:17Z
Title	The Atmospheric Remote-sensing Infrared Exoplanets Large-survey (ARIEL) payload electronic subsystems
Authors	FOCARDI, MAURO, Pace, E., Colomé, J., Ribas, I., Rataj, M., Ottensamer, R., FARINA, Maria, Di Giorgio, A. M., Wawer, P., PANCRAZZI, Maurizio, NOCE, Vladimiro, PEZZUTO, Stefano, MORGANTE, GIANLUCA, Artigues, B., Sierra-Roig, C., Gesa, L., Eccleston, P., Crook, M., MICELA, Giuseppina
Publisher's version (DOI)	10.1117/12.2231683
Handle	http://hdl.handle.net/20.500.12386/24374
Serie	PROCEEDINGS OF SPIE
Volume	9904

The Atmospheric Remote-sensing Infrared Exoplanets Large-survey (ARIEL) payload electronic subsystems

M. Focardi^{*a}, E. Pace^b, J. Colomé^c, I. Ribas^c, M. Rataj^d, R. Ottensamer^e, M. Farina^f,
A. M. Di Giorgio^f, P. Wawer^d, M. Pancrazzi^a, V. Noce^a, S. Pezzuto^f, G. Morgante^g, B. Artigues^c,
C. Sierra-Roig^c, L. Gesa^c, P. Eccleston^h, M. Crook^h, G. Micelaⁱ

^aINAF - OAA Arcetri Astrophysical Observatory, Largo E. Fermi 5, 50125 Firenze - Italy;

^bUniversity of Florence - Dept. of Physics and Astronomy, Largo E. Fermi 2, 50125 Firenze - Italy;

^cIEEC - CSIC Space Science Institute, Carrer de Can Magrans, 08193 Cerdanyola del Vallès - Spain;

^dCBK - Space Research Ctr. of Polish Academy of Science, Bartycka 18a Warsaw, 00-716 - Poland;

^eUniversity of Vienna - Institute of Astronomy, Türkenschanzstraße 17, 1180 Vienna - Austria;

^fINAF - IAPS Institute of Space Astrophysics and Planetology, Via del Fosso del Cavaliere 100,
00133 Roma - Italy;

^gINAF - IASF Space Astrophysics Institute, Via P. Gobetti, 101, 40129 Bologna - Italy;

^hSTFC - RAL Space - Rutherford Appleton Laboratory, OX11 0QX Harwell Oxford - UK;

ⁱINAF - OAPa Astronomical Observatory of Palermo, Piazza del Parlamento 1, 90134 Palermo -
Italy.

ABSTRACT

The ARIEL mission has been proposed to ESA by an European Consortium as the first space mission to extensively perform remote sensing on the atmospheres of a well defined set of warm and hot transiting gas giant exoplanets, whose temperature range between ~600 K and 3000 K.

ARIEL will observe a large number (~500) of warm and hot transiting gas giants, Neptunes and super-Earths around a range of host star types using transit spectroscopy in the ~2-8 μm spectral range and broad-band photometry in the NIR and optical. ARIEL will target planets hotter than 600 K to take advantage of their well-mixed atmospheres, which should show minimal condensation and sequestration of high-Z materials and thus reveal their bulk and elemental composition.

One of the major motivations for exoplanet characterisation is to understand the probability of occurrence of habitable worlds, i.e. suitable for surface liquid water. While ARIEL will not study habitable planets, its major contribution to this topic will result from its capability to detect the presence of atmospheres on many terrestrial planets outside the habitable zone and, in many cases, characterise them. This represents a fundamental breakthrough in understanding the physical and chemical processes of a large sample of exoplanets atmospheres as well as their bulk properties and to probe in-space technology.

The ARIEL infrared spectrometer (AIRS) provides data on the atmospheric composition; these data are acquired and processed by an On-Board Data Handling (OBDH) system including the Cold Front End Electronics (CFEE) and the Instrument Control Unit (ICU). The Telescope Control Unit (TCU) is also included inside the ICU. The latter is directly connected to the Control and Data Management Unit (CDMU) on board the Service Module (SVM). The general hardware architecture and the application software of the ICU are described. The Fine Guidance Sensor (FGS) electronics and the Cooler Control Electronics are also presented.

Keywords: Exoplanets atmospheres, remote sensing, transit spectroscopy, NIR photometer, payload electronics, Instrument Control Unit, Fine Guidance Sensor, telescope control.

*mauro@arcetri.astro.it; phone +39 055 275 5213

1. INTRODUCTION

ARIEL [1] has been proposed as a medium-class mission [2] to run for the ESA M4 selection in the context of the Cosmic Vision Program in order to cover the science gap leading to the next step forward for the extensive study of the atmospheres of Earths and super-Earths in their habitable zone.

Thanks to the previous studies on the EChO satellite [3], [4] proposed for M3, the overall ARIEL payload is going to be designed [5] in order to be fully compliant with respect to the limitations imposed by a medium-class mission. In particular all the payload electronics subsystems will aim at a full integration and simplification still respecting mass, power, volume and thermal requirements as imposed by ESA and Science.

The ARIEL payload module consists of an integrated suite of telescope, spectrometer and FGS/photometer along with the necessary supporting hardware and services. The payload optical and detection system comprises a 1-m class telescope [6] (including optical bench, metering structure and refocusing mechanism), the common optics, common in the sense that all instrument modules use this same set of fore-optics, including a potential fine steering mechanism.

A Mid-InfraRed spectrometer provides spectra at moderate spectral resolution between 1.95 and 7.8 μm in wavelength and a combined Fine Guidance Sensor and Near-InfraRed Photometer (FGS/NIRPhot) provides both redundant fine steering information and two additional narrow band photometric channels. A thermal hardware, including V-groove radiators and an on-board electronic system are complementary for an effective operational payload architecture.

The ARIEL payload electronics consist of three boxes that act as Remote Terminal Units via Spacewire (SpW) to the S/C CDMU. All high level commanding, operational sequencing and data storage is within the S/C CDMU. An Instrument Control Unit is foreseen as the main payload electrical interface to the ARIEL spectrometer electronics and the S/C. It is designed as a high-integrated subsystem able to host and to perform the main functions required for data processing and to fully control the overall Payload. The ICU electronics subsystems shall mainly drive and control the telescope mirrors actuators, the mirrors temperatures as well as interfacing the spectrometer's detector Cold Front End Electronics, collecting and processing the produced data. ICU is also linked to the ARIEL Fine Guidance Sensor to guarantee the spacecraft attitude and the fine pointing on the selected targets. The FGS Electronics (FGE) drives for FGS detectors, thermistors etc. Command & data handling, compression, processing and formatting, I/O to CDMS via SpW are other operational functions.

The ARIEL electronics also comprises a Cooler Control Electronics (CCE) used for power conditioning, control and monitoring and to manage the compressors as well as monitoring and recording the cooler housekeeping data.

This paper provides an overview on the payloads electronics subsystems, showing the main choices leading to a compliant design with respect to the ESA foreseen budgets.

2. ARIEL SCIENCE PAYLOAD

2.1 ARIEL Spectrometer

The baseline electrical architecture of the ARIEL Spectrometer (for a complete description refer to [7]) is based on three main blocks: the detector and its proximity electronics including the sensor ROIC (Read Out Integrated Circuit), the Cold Front End Electronics and the Instrument Control Unit, containing the Warm Front End Electronics (WFEE), part of the data acquisition chain.

The baseline detector for the ARIEL Spectrometer is the Teledyne MCT (Mercury Cadmium Telluride) array developed for NEOCam (512x512 pixels, 18 μm pitch); this kind of detector allows for non-destructive (or multi-accumulate) readout modes with some advantages. Indeed, the detector intrinsic capabilities can effectively reduce the equivalent readout noise, improve the signal to noise ratio and allow the identification and rejection of Cosmic Rays (CRs) thanks to specific data processing procedures [8].

Referring to Figure 1, the CFE electronics, currently based on a Sidecar-type integrated circuit, is aside the spectrometer detector and it is cooled down to $T < 55 \text{ K}$, as the rest of the AIRS. The analogue signals from the proximity electronics are pre-processed and A/D converted in the CFEE and the output is sent to the WFEE for digital data pre-processing.

The WFEE sits within the Instrument Control Unit which also houses the Telescope Control Unit as well as the Data Processing Unit (DPU) for scientific data compression, housekeeping (HK), telemetry and telecommands (TM/TC) management and data storing, before delivering them to the On-Board Computer (OBC) hosted by the S/C DMS (Data Management System). The ARIEL ICU hosts also the necessary power supply units (PSU) for power conversion and distribution to the ICU subsystems and the Spectrometer.

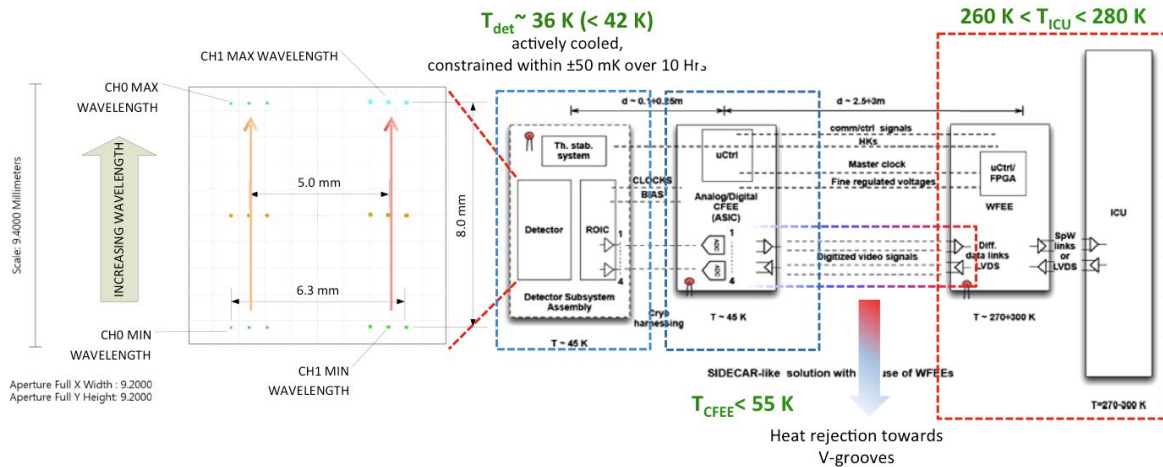

Figure 1: Block diagram of the baseline AIRS electronics chain showing the separation between the two channel spectra (left) on the focal plane, the detector ROIC and CFEE and, finally, the warm part of the electronics (right).

2.2 ARIEL Fine Guidance System and Near-IR photometer

The Fine Guidance System main task is to ensure the centering, focusing and guiding of the satellite, but it will also provide high precision astrometry and photometry of the target for complementary science. In particular, the data from the FGS will be used for de-trending and data analysis on ground. The sensor uses starlight coming through the optical path of the telescope to determine the changes in the line of sight of the ARIEL instrument. The attitude measurement is then combined with the information from the star tracker, and used as input for the control loop stabilizing the spacecraft through the high performance gyros. To meet the goals for guiding and photometry, four spectral bands are defined:

- FGS – Prime: 0.8-1.0 μm ;
- FGS – Redundant: 1.8-1.9 μm (option 1.0-1.2 μm);
- NIR-Phot1: 0.50-0.55 μm ;
- NIR-Phot2: 1.65-1.7 μm (option 1.25-1.9 μm , spectrometer R > 10).

In case of failure in the primary FGS channel, the information from the redundant channel can be used. The spectral bands are selected using a dichroic mirror.

By means of the use of the FGS in a closed loop configuration with the S/C attitude control system, the pointing stability between the instrument Line of Sight (LoS) and the science target will be controlled in order to ensure compliance with the photometric stability requirements.

The baseline architecture of both FGS and Near Infrared Photometer are fully described in Section 4.

3. INSTRUMENT CONTROL UNIT DESIGN

The present ICU architecture design has been conceived by the ARIEL Electronics and SW Working Group (WG), with the support of RAL Space (UK) at higher system engineering level (system-level) and thanks to some iterative design processes.

The ARIEL reduced complexity with respect to the previous EChO Payload design (8-11 and 11-16 μm channels are no longer present) [9], [10] allows for a simplification of the electronics units electrical and thermal I/Fs. At the same time, the present allocated resources by ESA for the ICU are considered a good compromise to control the instrument, to process the incoming data and to fulfil the overall Mission Scientific Requirements.

The ARIEL ICU will host as baseline a processor, a co-processing FPGA and several kinds of memories that will be used basically for local buffering and to support processing on scientific data. The latter, once properly processed, shall be sent to the S/C Solid State Mass Memory (SSMM), part of the S/C DMS, to be stored before sending them to Ground.

3.1 ICU description

The ICU baseline electrical architecture foresees four electronics boards, as illustrated in Figure 2, hosted by a single box made of aluminium alloy:

- 1 PSU (Power Supply Unit);
- 1 DPU (Data Processing Unit);
- 1 SCU (Spectrometer Control Unit);
- 1 TCU (Telescope Control Unit).

Additionally, the Unit implements a back plane for routing power lines, signals and as an electrical/mechanical IF to the electronic boards. It also hosts the grounding reference point and at least a TRP (Temperature Reference Point).

The architecture, similar to already adopted designs within other space projects with comparable assigned budgets [11], is based on a full cold redundancy with a minimal cross-strapping, as the only cross-strapped board is the Telescope Control Unit, as baseline. Alternatively, and based on a proper FDIR (Fault Detection, Isolation and Recovery) analysis, the SCU only could be cross-strapped or both TCU and SCU, but this depends on the overall needed resources (power, mass, volume) and added complexity, still to be assessed as normal work for the next phase.

All the PCBs are connected by means of a back panel used for routing purposes (signals and power lines). Between the Data Processing Unit and the Spectrometer Control Unit is foreseen a cPCI bus to exchange data exploiting a large bandwidth. In this architecture, the Warm Front End Electronics (WFEE) of the AIRS is included inside the SCU, as shown in Figure 2.

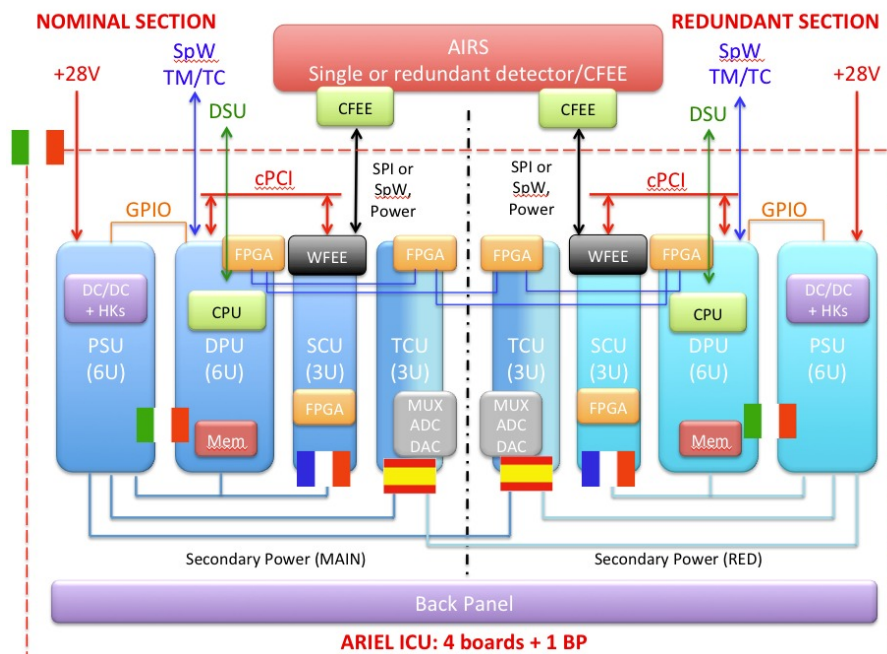

Figure 2: ICU baseline electrical architecture showing the main present national responsibilities.

The ICU overall electronics responsibility and management task is in charge of the University of Florence (Italy) while the task of System Engineering, Application SW (ASW) development and Unit AIV/AIT activities are in charge of INAF-OAA/IAPS (Italy) with contributions of CSIC/IEEC (Spain) and CEA (France). In particular the WFEE, being the last stage before scientific data processing and compression is in charge of CEA as well as the overall Spectrometer design (opto-mechanical design, detector, CFEE).

In the following we present the baseline ICU boards design along with their basic capabilities.

3.2 Power Supply Unit

It is a standard Power Supply Unit board hosting DC/DC converters with a number of secondary sections needed to support the adopted cross-strapped configuration as well. It is in charge of collecting currents, voltages on secondary outputs and temperatures HK (internally to the Unit). The Unit consumption monitoring is in charge of platform.

The PSU is mainly composed of three sections:

1. Power conditioning section hosting:
 - DC/DC conversion: main DC/DC for the generation of the +5V to be distributed to the other boards, Aux DC/DC for internal logic powering, HK DC/DC for powering the HK section for the acquisition of voltages/currents/temperatures HK;
 - Inrush current limitation;
 - Polarity inversion protection;
 - Power-on sequence generation;
 - Unit power-on reset generation;
 - EMI (Electro-Magnetic Interference) filtering.
2. Power distribution section hosting Output Power Controllers (OPC), which implement overcurrent and overvoltage protection capabilities, +28V voltage/current distribution line to TCU;
3. HK acquisition section with 12 bits ADCs for voltages and currents measurements, controlled by the processor via SPI (Serial Peripheral IF).

Each electronic board, apart TCU, is basically supplied by a main voltage level of +5V protected for overvoltage and overcurrent and locally on-board are derived, by means of a Point of Load, the secondary voltage levels needed by the electronic components.

3.3 Data Processing Unit

The Data Processing Unit hosts as baseline a CPU (the LEON3 UT699, as baseline, with 4 embedded SpW links), a co-processing FPGA, memories for booting (PROM), to host the ASW (E2PROM, NVM e.g. MRAM), for data buffering (e.g. SDRAM) and to support data processing (e.g. SRAM, SDRAM).

DPU is in charge of data processing and compression (lossless and variable lossy). It receives 16 bits raw data from the SCU and, once processed and compressed, it packetizes (CCSDS format) and send them towards the S/C SSMM for storing and later downloading to Ground.

3.4 Spectrometer Control Unit

The Spectrometer Control Unit hosts the Warm FEE part of the spectrometer (an FPGA as baseline) interfacing the detector Cold FEE and could also hosts the driver section of the Spectrometer calibration source/lamp (although it is included in the baseline design of TCU). The WFEE is in charge of CFEE clocking (at least a master clock is needed) and feeding (secondary finely regulated voltages) and it receives digitized scientific data and HKs from CFEE and detector (currents, voltages and temperatures).

An important issue of the SCU is the harness, electrically and thermally linking the WFEE (working at the Service Module temperature of 270-300 K) and the CFEE (working at $T < 55$ K, refer to Figure 1). It is in charge of “summing up the ramp” the detector(s) [8], chip readout and deglitching cosmic rays from raw data. Part of the proposed pre-processing tasks could be demanded to the DPU in order to share properly the overall data processing load as well as the needed resources in a harmonic design.

3.5 Telescope Control Unit

In order to accomplish the Telescope Control Unit requirements, the board hosts the Payload Module (PLM) thermal monitoring logic, the thermal control logic and the drivers of: M2 refocusing mechanism, M4 tip/tilt mechanism and IR calibration lamp. It will also host a power stage to feed all subsystems, a communication link to ICU's DPU and a feedback loop control from FGS for M4 driver logic (as shown in Figure 3).

For the thermal monitoring of the PLM, 50 thermistors will be powered by a stable current source and readout one by one with an ADC by means of a multiplexing stage. The redundant thermistors will be read by the redundant TCU board in order to reduce cross-strapping. The relevant thermal data will be sent to ICU's DPU for housekeeping telemetry, through the communication link.

The thermal control of the TCS subsystems (which are placed between critical detectors/mirrors and their thermal sink) will be carried out by monitoring their temperature, as explained previously, and activating their heaters once the correction has been calculated by the FPGA logic (a PID control loop). The heaters power will be supplied by its driver stage with a Pulse Width Modulator (PWM), if the power budget from ICU's permits it.

The M2 and M4 mechanisms and IR lamp are in an early stage of development. Each one will be controlled by the FPGA dedicated logic and powered by its driver stage, assuming that the power budget from ICU is enough. It is not foreseen any feedback loop for these subsystems except for M4. It requires data from FGS in order to operate, which will come through the ICU's DPU, using a proper communication link.

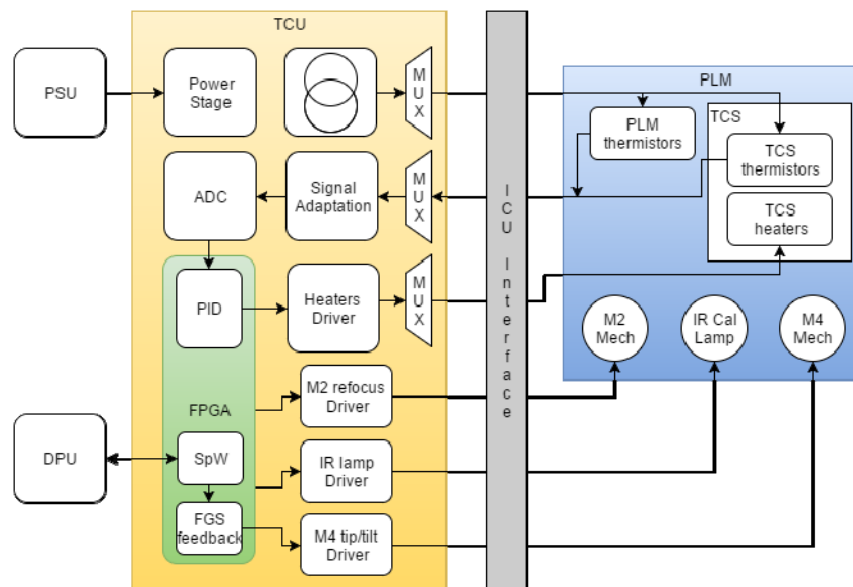

Figure 3: TCU baseline electrical architecture.

3.6 Budgets and mechanical design

The unit budgets, as allocated and defined in the ESA Payload Description Document (PDD), are summarized in Table 1. At the present time we expect to assign about one third of the overall power budget to the Telescope Control Unit (~15

W, including contingency). More detailed ICU power and mass budgets breakdown as well as an Unit physical dimensions estimate will be elaborated during the next study phase.

Concerning the ICU mechanical design we are evaluating two possible configurations, as illustrated in Figure 4. The baseline architecture exploits a single aluminium box hosting the four electronics boards and the back panel, laying on the box bottom part. The alternative one is instead based on four distinct and stacked boxes or “drawers”. In this stacked drawers configuration the power dissipation capability decreases from bottom to top. For this reason the units with a higher power dissipation will be placed on the bottom part. The proposed unit sequence from bottom to top is: PSU, DPU, SCU and TCU.

	Power CBE ¹ (W)	Mass CBE (Kg)	Dimensions (HxWxL)	Daily data volume CBE (Gbit)
Nominal	37.5	10.5	-	11.26
Contingency (%)	20	20	-	-
Total	45	12.6	-	11.46 (incl. HKs)

Table 1: Present ICU budgets. CBE¹ means Current Best Estimate.

The baseline solution presents reduced mass, power and volume budgets with respect to the alternative one, although the AIT (Assembly Integration & Test) and AIV (Assembly Integration & Verification) activities at subsystem level could be more complex to be managed as they could require a properly developed/dedicated HW and SW EGSE.

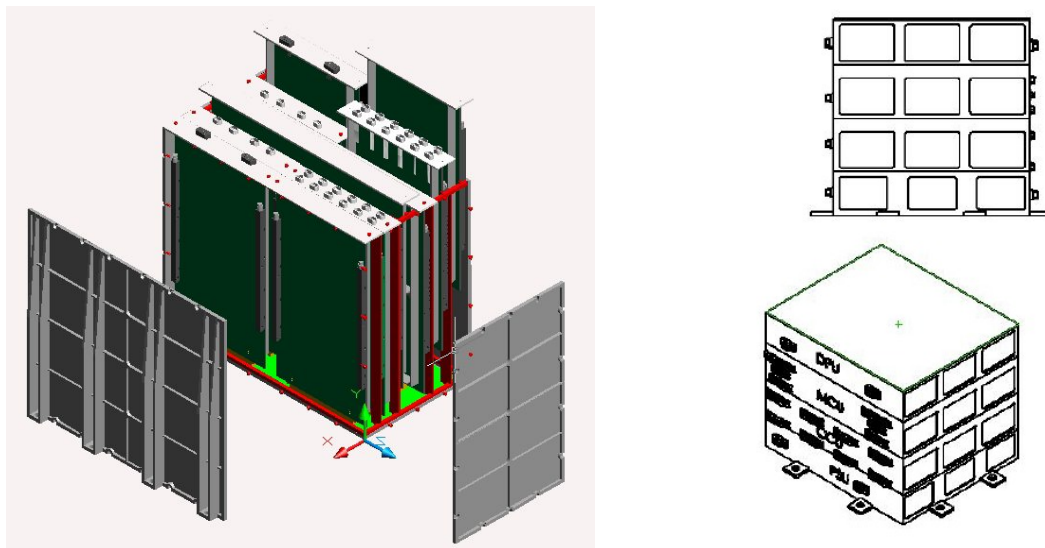

Figure 4: ICU mechanical design alternatives. The baseline architecture is shown on the left.

In contrast, the alternative design allows for an improved internal EM emissions control as well as an improved cross-strapping basic capability but, if adopted, it would require a more complex FDIR management by SW, often leading to time-consuming dedicated functional tests.

¹TCU included, Decontamination Mode excluded as the telescope decontamination task is in charge of S/C.

3.7 Harnessing and electrical interfaces

No flying harness is present in the baseline mechanical solution as the back panel is adopted for signal and power lines routing and to electrically and mechanically connect the PCBs inside the Unit box.

The harnessing towards the Payload is going to be properly defined during the next phase as it plays a fundamental role in thermal linking the warm electronics side to the cold electronics part, while the harnessing towards the S/C is hereunder itemized:

Nominal/Redundant Power Supply and control IFs:

- Power line: +28V + RTN (From S/C PCDU to ICU)
- Switch On HPC (Signal + RTN) (From S/C DMS to ICU)
- Switch Off HPC (Signal + RTN) (From S/C DMS to ICU)
- Switch Status BSM (Signal + RTN) (From S/C DMS to ICU)

Nominal/Redundant I/O digital TM/TC IFs:

- 1 or 2 (1 TM+1 TC) Standard Spacewire link(s) (From S/C DMS to ICU)

The MIL1553 BUS is not foreseen at the moment.

3.8 Data management and processing

In order to evaluate the needed ICU power computation resources and the amount of memories to store and process the data collected by the ARIEL science Spectrometer and TCU thermal system monitoring and activation, a resources analysis is going to be performed. The hardware configuration strongly depends on the ICU performance and storage capabilities, and the data volume to be managed on board (refer to Table 1 for the present expected daily data volume). In order to fulfil the scientific computation requirements we are going to investigate the sampling strategy, the on-board processing and the compression task, taking into account the high level requirements and their flow down to applicable design directives.

In particular, the following baseline data management and processing (for both scientific and housekeeping data) are foreseen board by board, with respect to the involved HW:

- SCU: summing up the ramp and pixels deglitching from cosmic rays (they could be performed by means of HW at FPGA level; studies are on-going on this issue);
- DPU: HW, SW or mixed HW/SW lossy and lossless compression, science data and HK buffering and packetization, TM/TC and I/F towards the S/C and Payload management, FDIR management and ICU subsystems control (CPU and co-processing FPGA);
- TCU: Telescope/Optical Bench temperatures measurements and A/D conversion, M2 and M4 mirrors HKs monitoring (by means of a FPGA hosting a PID controller, multiplexers and ADCs);
- PSU: HKs data i.e. ICU internal currents, voltages and temperatures A/D conversion (by means of multiplexers and 12 bits ADCs).

The choice of the best sampling and processing strategy for the selected array will depend on main aspects, in particular:

- the need to maximize the S/N in the measurements of both the selected bright and faint sources [1] and [2];
- the need to identify and remove Cosmic Rays and other unwanted glitches [8];
- the electronics operation limits;
- the power dissipation.

3.9 ARIEL on-board SW

The ICU overall SW is composed of the following parts:

- ICU Operating System (OS)
- ICU Basic SW
 - Bootstrap SW
 - Basic I/O SW
 - Service SW & Peripheral Drivers
- ICU Application SW, i.e.:
 - Instrument Control & Configuration SW
 - Data Processing & Compression SW
 - Process Control & FDIR SW

The Boot SW is part of the Basic SW and is installed on the PROMs of the ICU DPU board and allows loading the ICU Application Software. It contains all the low level drivers for the CPU board and its related interfaces.

The Instrument Control & Configuration SW refers to the software part performing the operations of the ARIEL scientific payload. It implements the data-handling functions of the instrument, manages the spectrometer operating modes and runs autonomous function. It implements the interface layer between the S/C and the instruments operation.

The Data Processing and Compression SW implements all the necessary on-board processing functionalities, included the on-board lossless and/or variable lossy compression (e.g. RICE algorithm). After the compression the SW prepares CCSDS packets for the transmission to the S/C Mass Memory.

Finally, the Process Control & FDIR SW is responsible for processes control and Fault Detection, Isolation and Recovery management.

A typical scheme of the instrument Operating Modes and transitions diagram managed by SW is reported in Figure 5.

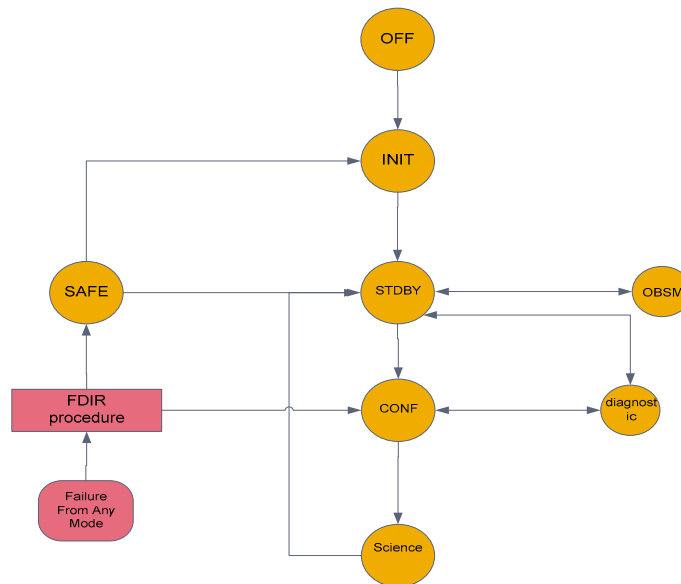

Figure 5: State transition diagram of instrument Operating Modes.

The SW development, and hence the SW deliveries, will be based on the ARIEL Consortium needs, on one side, and on the availability of external tools, like the satellite simulator and the Telescope (thermistors, heaters, etc.) and

Spectrometer (detector, CFEE, etc.) simulators, on the other side. In parallel, an ICU Unit SW simulator (composed of some subsystems simulators) shall be delivered to the institutes in charge of the SW and FW development for the other units.

4. FINE GUIDANCE SYSTEM / NIR PHOTOMETER DESIGN

The overall system (FGS and NIR photometer) is composed of an optics box at the instrument optical bench containing cryogenic optics with two detector modules operating at 45 K. At an intermediate temperature stage of 55 K, the cold front-end electronics are located. In the service module the FGS WFEE and FGS control electronics (FCE) are accommodated at a temperature of 270-300 K. They control and read the detectors and carry out the data processing. FGS systems are independent from the spectrometer instrument (AIRS), thus have their own power and data interfaces with the spacecraft. The FGS is also involved in the focusing of the main telescope. This will be done using images from the two detector arrays, which have different focus offset. The procedure will be controlled interactively from ground. The main Functional and Performance Requirements of the FGS are hereunder itemized:

- The FGS shall start and stop the relative attitude measurement on command from ICU. The attitude at the time of the command shall be used as the initial attitude for the relative attitude measurement;
- The FGS shall deliver new relative attitude measurements with 2-10 Hz update rate;
- The FGS shall deliver photometric measurements with a TBD rate;
- The specified attitude measurement accuracy shall be achieved for a spacecraft Relative Pointing Error (RPE) up to 10 milli-arcsec (goal: 5 milli-arcsec) 1- σ over 1s;
- All FGS components of the PLM shall show no degradation of functionality or performance after an exposure to temperatures of 40-353 K in non-operational mode;
- The FGS shall dump the complete detector images by command.

Moreover, the FGS shall permit in-orbit reprogramming of its software.

4.1 FGS optical module design

To better understand the design choices of the FGS control electronics a basic description of its optical module design is needed. It has been conceived with the following basic assumptions:

- Field of View (FoV) correlated with the telescope FoV and FGS detector dimensions at the level of: 37"x37" (on sky) \sim 0.22x0.22 degrees (internal field), where the usable FGS FoV is at the level: 17"x17" (0.1x0.1 degrees);
- Spectral bandwidth: 0.5-1.9 μ m is split into four bands;
- Detector: MCT FPA with minimum array and pixel size (15 μ m for MCT) and \sim 1024x256;
- Low distortion (< 1% level over FoV);
- Minimum bin/star image spread, Full Width at Half Maximum (FWHM): 6x6 pixels;
- Able to achieve centroiding to 1/10th of a pixel;
- Wave Front Error (WFE): 250 nm rms, i.e. telescope diffraction limit at 3 μ m + allocation for dichroics.

As a baseline telescope system for the FGS a Gregorian mirror-based telescope is proposed. The main parameters of the telescope are: focal length = 500 mm, F-number = 18, first mirror parabolic, second mirror spherical, central obscuration: \sim 3%. The optical scheme with system of dichroic mirrors is presented in Figure 6.

Two solutions of the optics design are considered. Both are based on the same telescope design with a different system dichroic set up.

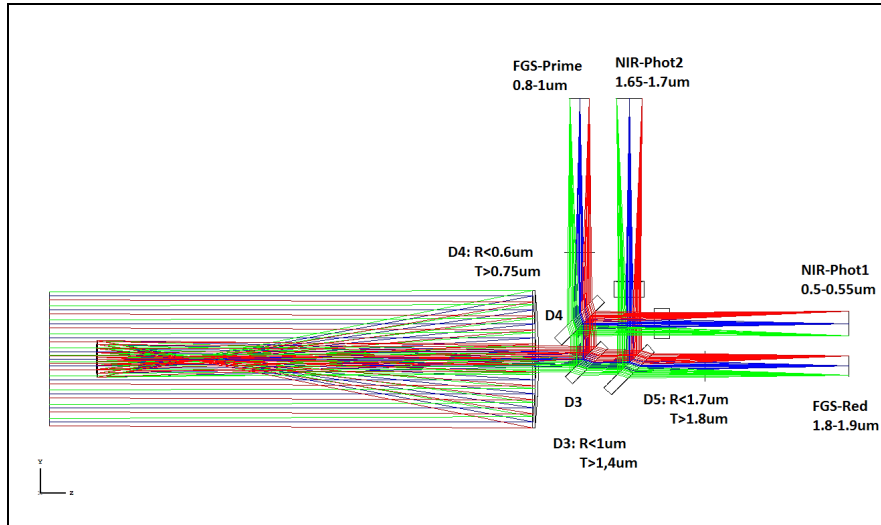

Figure 6: FGS four-channels baseline design.

The four-channel FGS configuration needs to use three dichroic beam-splitters. This allows the detection of the signal from two channels on a single 1024x256 pixels detector. This concept of the dichroic system is shown in Figure 6. To obtain equal optical paths in two parallel channels a negative lens is used in each NIR-Photometer channel. Additional optical elements diversify the FoV in FGS channels and photometry channels. Nevertheless, this does not compromise the system because of the fact that the maximum FoV is bigger than the usable FGS FoV. It must however be taken into account as a design restriction, that applying two long detectors limits the parallel channels separation to 11.5 mm between their optical axes.

Because of science needs of the spectrometric data in NIR spectral range, the FGS was additionally redesigned to check the mechanical and optical possibility to use dispersing elements in one of the photometric channels. The design of this option is shown in Figure 7. In one channel a grism is implemented, which allows to obtaining the spectrum on a part of the detector.

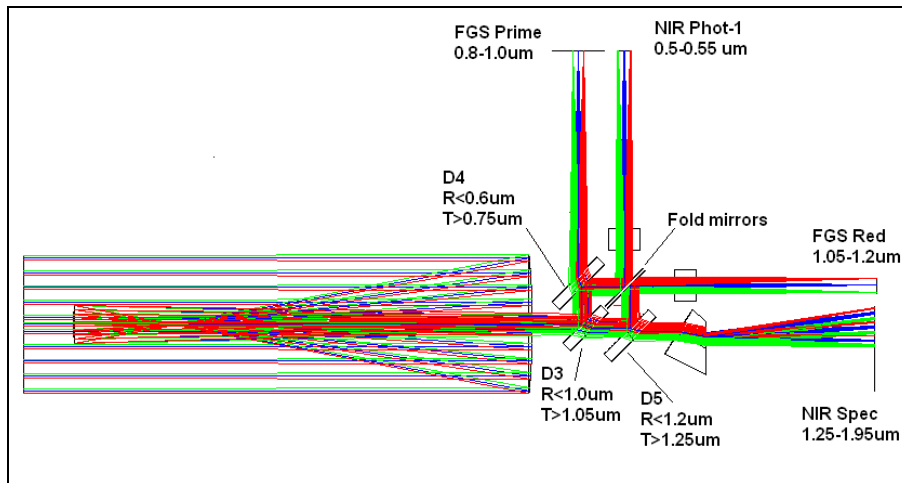

Figure 7: FGS optional design.

Predictions of the FGS optical performance have been made based on spot diagrams shown in Figure 8, which were obtained for each of the four channels. Spot diagram dimensions are compared with the reference square of 90x90 μm (6x6 pixels) and the Airy disc diameter (depicted as black circles). In all cases the preliminary design and optimization of the optical system allows to obtain the diffraction limited (or near diffraction limited) performance in every channel.

In case of the option hosting the spectrometric channel, the main design parameter is the requested spectral resolution, which should be $R > 10$. A first approximation of the spectral resolution based on the spot diagrams was made for the $11'' \times 11''$ FoV and for wavelengths corresponding with the middle and the borders of the spectral range ($1.25 \mu\text{m}$, $1.6 \mu\text{m}$ and $1.95 \mu\text{m}$).

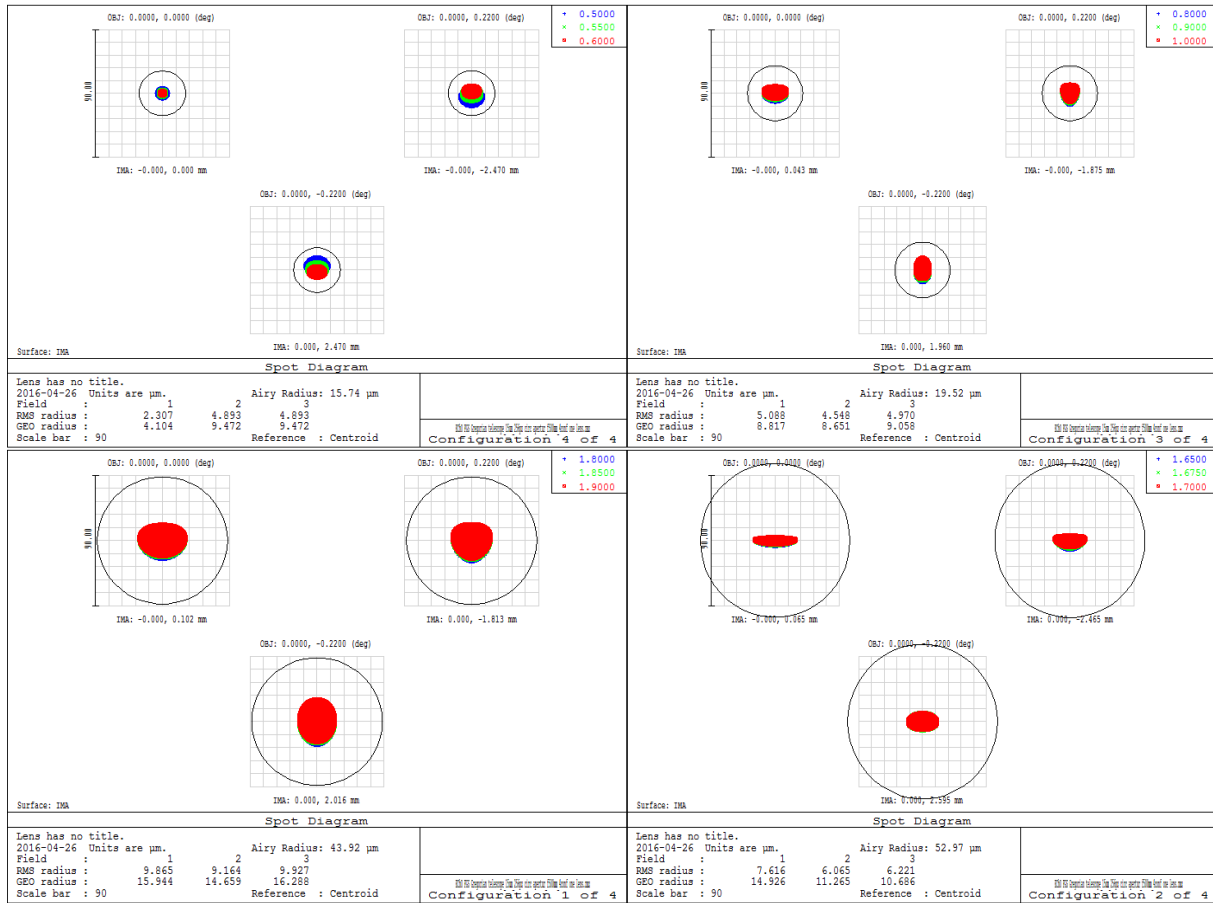

Figure 8: Spot diagrams for the FGS baseline solution.

As shown in Figure 9, the monochromatic images for these three wavelengths are completely separated which means that as minimum we can achieved a spectral resolution $R = 1250 \text{ nm}/350 \text{ nm} = 3.5$.

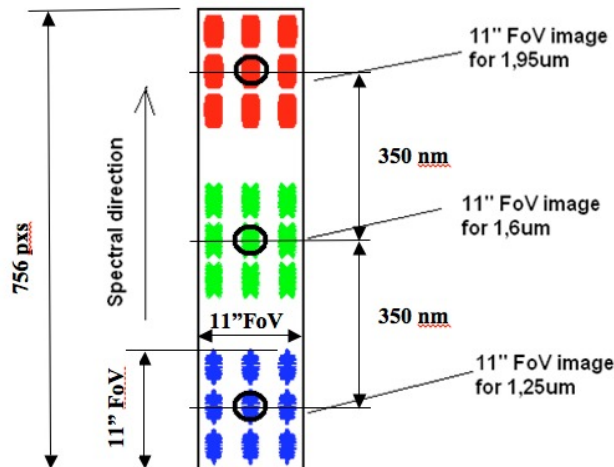

Figure 9: Spot diagrams for the spectral resolution estimation.

The black circle inside each monochromatic image represents the star image inside the spectrometer FoV. It will be only one star in the FoV. With the assumption that the background is dark, the expected resolution is > 10 .

4.2 FGS Control Unit Hardware and Software

The FGS has its own control electronics in the SVM to carry out all necessary communication, control and data processing tasks. It drives and read the FGS detector electronics, establishes a control loop with the spacecraft and delivers scientific data products. The FGS provides photometry measurements of the science target for its two detector arrays and it supports the star trackers with precise measurements (at 10 Hz) of the target in its field of view. These data products are also sent as science data products to ground. On-board compression is foreseen to reduce the overall telemetry volume.

The FGS has few sensors and HK values. The FGS telemetry volume depends on the related parameter configuration, which is < 4 kbit/s if no imagettes (i.e. small images of a few pixels) are sent and < 10 kbit/s if e.g. 10×10 pixel imagettes are included.

The FGS control electronics in the service module are independent from the spectrometer channels and the main spectrometer's ICU. They will consist of the following sub-units:

- mechanical chassis: a typical warm electronics box, with a total mass estimation of 6 kg;
- digital electronic boards for control and data processing;
- SpaceWire interfaces are used where applicable;
- power supply unit providing secondary voltages to the FGS components.

The FGS will have to carry out and support a number of different tasks through its application software. There will be functions to control the FGS subsystems, process the detector data and communicate with the spacecraft. The FGS application software will offer its functionality in the form of ECSS service commands and reports. The software includes FDIR functionality and offers several modes of operation to support maintenance and calibration activities.

The main requirement of the FGS is the centroiding performance (10 milli-arcsec are required) at 10 Hz. The FGS will also be used for focusing the main telescope through a dedicated imaging mode. For the best support of the operating modes, several centroiding and data extraction algorithms will be implemented, fully configurable by parameters and commands.

In the warm FGS control electronics the data will be processed in real-time. Output data products are reformatted images, centroid coordinates, dimensions and errors in both axes, photometry, glitch count and housekeeping. Additional data processing capabilities include frame stacking for PSF measurements.

A number of calibration steps need to be carried out before the centroiding can be applied, most importantly bias and flat field correction. For the purpose of glitch detection and correction, several sub frames will be buffered.

The detectors will be used in windowing mode to optimize integration time for collecting science data. The main detector contains FGS prime and the NIR/Phot1 channel. The FGS will be operated at 10 Hz and science data coming from the FGS with this frame rate will be collected. The NIR/Phot1 channel will operate with a frame rate defined for the best SNR for this channel. The redundant detector will only be used for photometric purposes. In the case of failure of the FGS prime, the FGS redundant will take over the guiding function. The frame rate for both spectral channels will be defined to maximize SNR.

Science data products that will be downlinked will be compressed in a lossless manner. Images will be compressed using an integer wavelet transform with an arithmetic compression backend. This will yield a factor of 3, depending on the noise.

Concerning centroids, compression will be much less efficient, as most parameters will be floats. Given the estimated numbers from above, a downlink rate of ~300 kbit/s would be needed for a 10 Hz rate. For a 20x20 pixel window, this would become ~30 kbit/s. If only the centroids and no images are transmitted we expect a data rate of 4 kbit/s. All of these rates will be configurable as defined by the on ground needs.

5. COOLER CONTROL ELECTRONICS

The cooler is operated through a dedicated Control Electronics module. The Control Electronics provides all the power conditioning, control and monitoring to manage the driving of the compressors as well as monitoring and recording the cooler housekeeping data.



Figure 10: Typical cooler drive electronics box for a two stages compressor set.

The Control Electronics comprises the following main functions:

- Command & Telemetry Interface;
- System Control;
- Digital to Analogue Converters (DACs);
- Current Control Loops;
- Drive Amplifiers;
- Sensor Signal Conditioning;
- Sampled Data Acquisition;
- Launch Lock;
- EMC Filter;
- Auxiliary power supply;

- Active line filter;
- Critical Parameter Determination;
- Vibration Sampling rate;
- Waveform Generation;
- External Electrical interfaces.

The cooler drive part of the electronics generates the driving waveforms and amplifies them according to the required compressor stroke. The stroke is measured either directly using a position sensor, or indirectly from the compressor motor back-EMF, and this is adjusted to the demanded stroke through a control loop.

Without filtering, the (approximately) sinusoidal driving currents required for the compressors would induce a large ripple on the current demanded from the spacecraft bus. The Control Electronics will therefore incorporate current regulation in the form of an active line filter to minimise the ripple seen by the spacecraft bus. This part of the electronics will be designed to meet the conducted emissions requirements of the spacecraft.

A “launch lock” feature will be incorporated in the electronics to prevent excessive motion of the compressor pistons under launch vibrations. This can simply be achieved by shorting the compressor drive coils so that any motion of the motor coils induces a back-EMF, which opposes their motion. This technique has been thoroughly qualified on previous coolers and was employed successfully on the Planck JT compressors.

If required, active vibration control can be incorporated in the Control Electronics; this is a control algorithm that nulls in-axis vibration of the compressors by measuring the exported vibration and correcting the driving waveforms such that it is minimised.

In addition to driving the compressors, the Control Electronics will include everything necessary to power and read out the instrumentation on the cooler. This will incorporate auxiliary power supplies, analogue signal conditioning, data acquisition and telemetry compilation. A complete telemetry format can be sent immediately upon request or provided on a periodic basis, as determined by the mission requirements.

6. CONCLUSIONS

In this paper we have provided an overview of the current design status of the ARIEL Payload electronic subsystems, as they underwent the Mission Consolidation Review (MCR), held by ESA on 9th June 2016 in ESTEC (NL). Until the end of the ARIEL Assessment Phase a more detailed study will be conducted in order to satisfy all the Payload scientific and technological requirements, as required by ESA and to be addressed by the ARIEL Payload Consortium.

7. ACKNOWLEDGMENT

The Authors are grateful to the European Space Agency (ESA) for the support provided by the ARIEL Study Team, to the University College of London (UCL) leading the Project (PI Giovanna Tinetti) and to the Rutherford Appleton Laboratory (RAL) Engineers for the invaluable support at System Engineering Level.

We wish also to acknowledge the Italian Space Agency (ASI) for the financial contribution to the ARIEL project in the framework of the ASI-INAF agreement 2015-038-R.0.

REFERENCES

- [1] G. Tinetti and the ARIEL Consortium, “The science of ARIEL (atmospheric remote-sensing infrared exoplanet large-survey)”, Proc. SPIE AT+I, (2016).
- [2] L. Puig et al., “ESA M4 mission candidate ARIEL”, Proc. SPIE AT+I, (2016).
- [3] G. Tinetti et al., “EChO. Exoplanet Characterization Observatory”, Experimental Astronomy, Vol. 34, (2012).
- [4] G. Tinetti et al., “The EChO Science Case”, Experimental Astronomy, Vol. 40, Issues 2, (2015).

- [5] P. Eccleston et al., "An integrated payload design for the Atmospheric Remote-sensing Infrared Exoplanet Large-survey (ARIEL)", Proc. SPIE AT+I, (2016).
- [6] V. Da Deppo et al., "Design of an afocal telescope for the ARIEL mission", Proc. SPIE AT+I, (2016).
- [7] J.P. Beaulieu et al., "AIRS: the infrared spectrometer of the ARIEL space mission", Proc. SPIE AT+I, (2016).
- [8] M. Farina et al., "Preliminary study of the EChO data sampling and processing", Proc. SPIE, Vol. 9143 - 914356, (2014).
- [9] M. Focardi et al., "The instrument control unit of the EChO space mission: electrical architecture and processing requirements", Proc. SPIE, Vol. 9143 – 91434H, (2014).
- [10] M. Focardi et al., "EChO payload electronics architecture and SW design", Experimental Astronomy, Vol. 40, Issues 2-3, (2015).
- [11] M. Focardi et al., "The Instrument Control Unit of the ESA-PLATO 2.0 mission", Proc. SPIE AT+I, (2016).