



Publication Year	2008
Acceptance in OA	2024-01-31T11:04:10Z
Title	Sorption cooler system operation plan
Authors	MORGANTE, GIANLUCA
Handle	http://hdl.handle.net/20.500.12386/34679
Volume	PL-LFI-PST-PL-011 ANNEX I



TITLE:

Sorption Cooler System ***Operation Plan***

DOC. TYPE: Operation Plan

PROJECT REF.: PL-LFI-PST-PL-011 ANNEX I

PAGE: 48

ISSUE/REV.: 1.0

DATE: July 2008

Prepared by	G. MORGANTE LFI - Project System Team SCS – System Engineer	Date: Signature: _____	
Agreed by	C. BUTLER LFI - Program Manager A. ZACCHEI LFI DPC Manager	Date: Signature: _____	
Approved by	N. MANDOLESI LFI - Principal Investigator	Date: Signature: _____	



DISTRIBUTION LIST

Recipient	Company / Institute	E-mail address
T. PASSVOGEL	ESA – Noordwijk	tpassvog@estec.esa.nl
G. CRONE	ESA – Noordwijk	Gerald.Crone@esa.int
P. OLIVIER	ESA – Noordwijk	Pierre.olivier@esa.int
J. TAUBER	ESA – Noordwijk	jtauber@rssd.esa.int
L. PEREZ CUEVAS	ESA – Noordwijk	leticia.perez.cuevas@esa.int
O. PIERSANTI	ESA – Noordwijk	Osvaldo.Piersanti@esa.int
C. DAMASIO	ESA – Noordwijk	Claudio.Damasio@esa.int
R. LAUREIJS	ESA – Noordwijk	Rlaureij@esa.int
C. WATSON	ESA – Darmstadt	Christopher.J.Watson@esa.int
M. SCHMIDT	ESOC – Darmstadt	Micha.Schmidt@esa.int
S. FOLEY	ESOC – Darmstadt	Steve.Foley@esa.int
PGSSG	Ground Segment WG	pgssg@rssd.esa.int
ICWG	Instrum. Coord. WG	icwg@rssd.esa.int
COWG	Cryo Ops WG	cowg@rssd.esa.int
B. COLLAUDIN	AAS – Cannes	Bernard.Collaudin@thalesalieniaspace.com
J.P. CHAMBELLAND	AAS – Cannes	Jean-Philippe.Chambelland@thalesalieniaspace.com
D. PEARSON	JPL – Pasadena	David.P.Pearson@jpl.nasa.gov
U. ISRAELSSON	JPL – Pasadena	Ulf.E.Israelsson@jpl.nasa.gov
C. LAWRENCE	JPL – Pasadena	Charles.Lawrence@jpl.nasa.gov
D. SANTOS	LPSC - Grenoble	Daniel.Santos@lpsc.in2p3.fr
P. STASSI	LPSC - Grenoble	stassi@lpsc.in2p3.fr
F. MELOT	LPSC - Grenoble	frederic.melot@lpsc.in2p3.fr
C. BUTLER	IASF – Bologna	butler@iasfbo.inaf.it
A. ZACCHEI	OATS – Trieste	zacchei@oats.inaf.it
A. GREGORIO	UniTS – Trieste	anna.gregorio@ts.infn.it
L. TERENCEZI	IASF – Bologna	terenzi@iasfbo.inaf.it
N. MANDOLESI	IASF/CNR – Bologna	reno@iasfbo.inaf.it
C. BUTLER	IASF/CNR – Bologna	butler@iasfbo.inaf.it
M. BERSANELLI	UNIMI – Milano	marco.bersanelli@mi.infn.it
LFI System PCC	IASF – Bologna	lfispcc@iasfo.inaf.it



CHANGE RECORD

Issue	Date	Sheet	Description of Change
0.1	25/09/2006	All	First draft of document
0.3	30/10/2006	Ch 2,3	Review of Chapter 2 and 3
0.5	20/12/2006	All	General integration and revision
1.0	08/07/2008	All	Chapters 4, 5, 6, 7 update and general revision



TABLE OF CONTENTS

1. SCOPE.....	6
LIST OF ACRONYMS	7
2. APPLICABLE & REFERENCED DOCUMENTS.....	12
2.1.1. Applicable Documents.....	12
2.1.2. Referenced Documents.....	12
3. SYSTEM OVERVIEW.....	13
3.1. THE PLANCK SORPTION COOLER SYSTEM.....	13
3.1.1. THE SORPTION COOLER COMPRESSOR (SCC).....	14
3.1.2. THE SORPTION COOLER PACE.....	14
3.1.3. THE SORPTION COOLER ELECTRONICS (SCE).....	15
3.2. SCS OPERATION MODES	16
4. OPERATION PROCESSES	20
4.1. INFRASTRUCTURE.....	20
4.1.1. SOFTWARE	20
4.1.1.1. Data transfer (Between DPC's and to PSO).....	20
4.1.1.2. DPC SOFTWARE.....	20
4.1.1.3. INSTRUMENT WORKSTATIONS AT MOC (IW@MOC)	20
4.1.1.4. ARCHIVE	21
4.1.2. HARDWARE.....	21
4.1.3. INTERFACES.....	21
4.2. MANAGEMENT	21
4.3. STAFFING	21
4.4. CONTACT INFORMATION	22
5. OPERATIONS CONTEXT	23
5.1. DATA PROCESSING AND MONITORING	24
5.1.1. ROUTINE ACTIVITIES.....	24
5.1.2. COMMISSIONING AND CPV OPERATIONS.....	25
5.1.2.1. COMMISSIONING OPERATIONS.....	25
5.1.2.2. CPV OPERATIONS	25
5.1.3. CONTINGENCY ACTIVITIES	26
5.1.4. NON-ROUTINE ACTIVITIES.....	26
5.2. INSTRUMENT TELE-COMMANDING.....	26
5.2.1. ROUTINE OPERATIONS.....	26
5.2.1.1. COMPRESSOR TUNING	27
5.2.1.2. COLD END TUNING.....	28
5.2.2. NON-ROUTINE OPERATIONS.....	28
5.2.2.1. COOLER SWITCH-OVER	28
5.2.2.2. REGENERATION.....	28
5.2.3. COMMISSIONING AND CPV OPERATIONS.....	29
5.2.3.1. COMMISSIONING OPERATIONS.....	29
5.2.3.2. CPV OPERATIONS	29
5.2.4. CONTINGENCY ACTIVITIES	30
5.3. SOFTWARE MAINTENANCE	30
5.3.1. NEW SOFTWARE RELEASE	30
5.3.2. END OF SURVEY	30
5.4. ARCHIVE DEVELOPMENT.....	31



6. NOMINAL OPERATIONS.....	32
6.1. SCS ROUTINE PHASE SHEETS	32
6.1.1. SCS DAILY OPERATIONS SHEET	32
6.1.2. WEEKLY OPERATIONS SHEET	33
6.1.3. MONTHLY OPERATIONS SHEET	33
6.2. COMMISSIONING AND CPV OPERATIONS SHEET.....	34
6.2.1. COMMISSIONING OPERATIONS SHEET	34
6.2.2. CPV OPERATIONS.....	34
6.3. NON-ROUTINE OPERATIONS SHEET	35
6.3.1. CONTINGENCY RESPONSE	35
6.3.2. COOLER SWITCH-OVER.....	35
6.3.3. REGENERATION	35
7. NOMINAL OPERATION PROCEDURES.....	36
7.1. COMMISSIONING AND CPV OPERATIONS	36
7.1.1. REAL TIME HK DATA ANALYSIS	36
7.1.2. OFFLINE DATA ANALYSIS	36
7.1.3. CROSS-CHECK SCS AND HFI THERMAL DATA	37
7.1.4. UPLINK OPERATIONS: CHECK INSTRUMENT PROCEDURE	37
7.1.5. COMMISSIONING AND CPV DAILY MEETING.....	38
7.2. ROUTINE OPERATIONS.....	38
7.2.1. READ ONE DAY DATA.....	38
7.2.2. REAL TIME ASSESSMENT (RTA)	39
7.2.3. TELEMETRY QUICK LOOK (TQL).....	39
7.2.4. TELEMETRY HANDLING (TMH).....	40
7.2.5. LIFE SYSTEM ANALYSIS.....	40
7.2.6. DAILY QUALITY REPORTS	41
7.2.7. SCS CONVERTED DATA EXPORT VS HFI DPC.....	42
7.2.8. COMPARISON WITH HFI THERMAL: DOWNLOAD HFI HK DATA.....	42
7.2.9. UPLINK OPERATIONS: INSTRUMENT PROCEDURE REQUESTS	43
7.2.10. DAILY MEETING	43
7.2.11. READ ONE WEEK DATA.....	44
7.2.12. SCS REDUCED DATA EXPORT VS HFI DPC.....	44
7.2.13. WEEKLY HEALTH REPORTS	45
7.2.14. WEEKLY MEETING	45
7.2.15. READ ONE MONTH DATA	46
7.3. TIMELINE	46
7.4. SUMMARY OF ACTIVITIES AND TASKS	46
8. CONTINGENCY OPERATIONS.....	47
8.1. CONTINGENCY REACTION: NCR AND NRB	47
8.2. CONTINGENCY REACTION: SCS INTERNAL MEETING.....	47
8.3. CONTINGENCY REACTION: INSTRUMENT PROCEDURE REQUESTS.....	48



1. SCOPE

This document, Annex to the LFI Operation Plan PL-LFI-PST-PL-011 [RD-1], describes the in-flight planned operations for the Planck Sorption Cooler System (SCS) as defined in the Science Operations Implementation Plan [RD-2] and in the DPC Operations Scenario [RD-3]. Sorption Cooler operations will be under the responsibility of the SCS Instrument Operations Team (SCS IOT), located at the LFI DPC (Data Processing Centre) site, where Level 1 is run, with the support of the DPC team and of a number of specialists distributed geographically.

Three main statements identify the SCS operation environment (see Chapter 5):

1. The SCS operational main task is to provide the most efficient and stable temperature reference to the HFI and LFI.
2. For all data analysis purposes SCS TM is considered HK.
3. All SCS activities at LFI DPC are part of the Level 1 only



LIST of ACRONYMS

ABCL	As-Built Configuration List
ACK	Acknowledgement
ACMS	Attitude Control Management System
AD	Applicable Document
AIV	Assembly, Integration and Verification
ASI	Agenzia Spaziale Italiana (Italian Space Agency)
ASPI	Alcatel SPace Industry
ASW	Application SoftWare
AVM	Avionics Verification Model
AWG	ESA's Astronomical Working Group
BBM	(DPC software) Bread-Board Model
BEM	Back End Module (LFI)
BEU	Back End Unit (LFI)
BIN, bin	Binary
BOL	Begin of Life
CC	Change Control
CCB	Configuration Control Board
CCE	Central Check-out Equipment
CCS	Central Check-out System
CDMS	Command and Data Management Subsystem
CDMU	Central Data Management Unit
CFRP	Carbon Fiber Reinforced Plastic
CIDL	Configuration Item Data List
CoG	Centre of Gravity
CQM	Cryogenic Qualification Model
CRC	Cyclic Redundancy Check
CS	Conducted Susceptibility
CSL	Centre Spatial de Liege
CTE	Coefficient of thermal expansion
CTR	Central Time Reference
DAE	Data Acquisition Electronics (LFI)
DC	Direct Current
DDID	Data Distribution Interface Document
DDS	Data Distribution System
DEC, dec.	Decimal
DFE	Data Front End
DM	(DPC software) Development Model
DMS	Documentation Management System
DPC	Data Processing Centre
DPU	(Data (or Digital) processing Unit
DRS	Data Reduction Software
DS	Data Server
DTCP	Daily Telecommunication Period
ECR	Engineering Change Request
EE	End to End test



Planck LFI Sorption Cooler System Operation Plan

Document No.: PL-LFI-PST-PL-011
Annex I
Issue/Rev. No.: 1.0
Date: July 2008

EEPROM	Electrically Erasable PROM
EGSE	Electrical Ground Support Equipment
EM	Engineering Model
EMC	Electro-Magnetic Compatibility
EMI	Electro-Magnetic Interference
EOL	End of Life
EPS	Electrical Power Subsystem
EQM	Engineering-Qualification Model
ESA	European Space Agency
ESD	Electro Static Discharge
ESOC	European Space Operations Centre
ESTEC	European Space Technology and Research Centre
FCS	Flight Control System
FCU	Focal Plane Control Unit (SPIRE)
FDIR	Failure Detection, Isolation and Recovery
FEM	Front End Module (LFI)
FEU	Front End Unit (LFI)
FID	Function Identifier
FM	Flight Model
FMECA	Failure-Modes, Effects and Criticality Analysis
FOP	Flight Operations Plan
FOV	Field Of View
FPA	Focal Plane Assembly
FPS	Focal Plane structure
FPU	Focal Plane Unit
FS	Flight Spare
FTS	File Transfer System
GS	Ground Segment
H/W	Hardware
HEX, hex.	Hexadecimal
HFI	High Frequency Instrument (Planck)
HK	House Keeping (data)
HPFTS	Herschel-Planck File Transfer System
HPLM	Herschel Payload Module
IAP	Institut d'AstroPhysique
IAS	Institut d'Astrophysique Spatiale
ICD	Interface Control Document
ICS	Instrument Commands Sequence
ICWG	Instrument Coordination Working Group
ID	Identifier
IDT	Instrument Development Team
IID	Instrument Interface Document
IID-B	Instrument Interface Document - part B
ILT	Instrument Level Test
IMT	Integrated Module Tests
IOM	Instrument Operations Manager
IOT	Instrument Operations Team
IRD	Interface Requirements Document
IST	Integrated System Test
ITT	Integration and Test Team



Planck LFI Sorption Cooler System Operation Plan

Document No.: PL-LFI-PST-PL-011
Annex I
Issue/Rev. No.: 1.0
Date: July 2008

JPL	Jet Propulsion Laboratory
JT	Joule Thompson
kbps	kilobits per second
LCL	Latch Current Limiter
LEOP	Launch and Early Operations Phase
LFI	Low Frequency Instrument (Planck)
LGA	Low Gain Antenna
LL	Low Limit
LPSC	Laboratoire Physic Subatomic et Cosmologie
LSB	Least Significant Bit
LVHX	Liquid-Vapour Heat eXchanger
Mbps	Megabits per second
MCC	Mission Control Centre
MGSE	Mechanical Ground Support Equipment
MIB	Mission Information Base (database)
MLI	Multilayer Insulation
MOC	Mission Operations Centre
Mol	Moment of Inertia
MOS	Margin Of Safety
MPS	Mission Planning System
MSB	Most Significant Bit
MTL	Mission Time Line
N/A, n.a.	Not Applicable
NaN	Not a Number
NCR	Non Conformance Report
NRT	Near-Real-Time
OATs	Osservatorio Astronomico di Trieste
OBCP	On-Board Control Procedure
OBSM	On-Board Software Maintenance
OD	Operational Day
OIRD	Operations Interface Requirements Document
OM	(DPC software) Operations Model
OOL	Out-of-Limits
PA	Product Assurance
PC	Pre-Cooler
PCDU	Power Control & Distribution Unit
PCS	Power Control Subsystem
PEC	Packet Error Control
PFM	Proto Flight Model
PGSSG	Planck Ground Segment System Group
PID	Parameter Identifier
PLFEU	Planck LFI Front End Unit (FEU)
PLM	Payload Module
PM	Project Manager
PPLM	Planck Payload Module
PR	Primary Reflector
PROM	Programmable Read Only Memory
PS	Project Scientist
PSO	Planck Science Office
PSS	Procedures, Specifications and Standards



Planck LFI Sorption Cooler System Operation Plan

Document No.: PL-LFI-PST-PL-011
Annex I
Issue/Rev. No.: 1.0
Date: July 2008

PSVM	Planck Service Module
PV	Performance Verification
QA	Quality Assurance
QLA	Quick Look Analysis (software)
RAM	Random Access Memory
RD	Reference Document
RF	Radio Frequency
RFW	Request for Waiver
RLA	Register Load Address
ROM	Read Only Memory
RT	Real Time
RTA	Real-Time Analysis
RTU	Remote Terminal Unit
S/C	Spacecraft
S/W	Software
SAA	Solar Aspect Angle
SC	SpaceCraft
SCC	Sorption Cooler Compressor
SCCE	Sorption Cooler Cold End
SCE	Sorption Cooler Electronics
SCOE	Special Check Out Equipment
SCOS	Spacecraft Control and Operations System
SCP	Sorption Cooler Pipes
SCS	Sorption Cooler Subsystem (Planck)
SDE	Software Development Environment
SDU	Service Data Unit
SFT	Short Functional Test
SID	Structure Identifier
SLE	Standard Laboratory Equipment
SPACON	SPAcecraft CONtroller
SPR	Software Problem Report
SR	Secondary Reflector
SSMM	Solid State Mass Memory
SS	Stainless Steel
ST	Science Team
STM	Structural/Thermal Model
STMM	Simplified Thermal Model
SVM	SerVice Module
SVT	System Validation Test
TA	Telescope Assembly
TBC	To Be Confirmed
TBD	To Be Defined
TBS	To Be Specified
TBW	To Be Written
TC	TeleCommand
TCE	Telecommand Encoder
TCS	Thermal Control System
TID	Task Identifier
TM	Telemetry
TMM	Thermal Mathematical Model



Planck LFI
Sorption Cooler System
Operation Plan

Document No.: PL-LFI-PST-PL-011
Annex I
Issue/Rev. No.: 1.0
Date: July 2008

TMP	Telemetry Processor
TMU	Thermo Mechanical Unit (Sorption cooler)
TOD	Time-Ordered Data
TOI	Time-Ordered Information
TQL	Telemetry Quick-Look
UM	User's Manual
URD	Users Requirements Document
UTC	Universal Time Coordinate(d)
VG	V-Groove radiator
WU	Warm Units



2. APPLICABLE & REFERENCED DOCUMENTS

2.1.1. Applicable Documents

Ref.	Doc. Ref. Nr.	Issue/Rev	Document Title
AD-01	PT-IID-A-04624	4.0	CREMA
AD-02	PT-LFI-04142	2.1	FIRST/PLANCK INSTRUMENT INTERFACE DOCUMENT – PART B
AD-03	PL-LFI-PST-ID-002	3.1	Planck Sorption Cooler ICD
AD-04	ES518265	B1	TMU Specification Document
AD-05	PL-MA-CRS-0036	2.0	Planck Sorption Cooler Electronics User Manual
AD-06	Planck/PSO/2007-017	1.0	Planck Cryo Chain Operations
AD-07	PL-LFI-OAT-PL-001	1.5	Science Operations Implementation Plan

2.1.2. Referenced Documents

Ref.	Doc. Reference Nr	Issue/Rev	Document Title
RD-01	PL-LFI-PST-PL-011	2.1	Planck LFI Operation Plan
RD-02	PL-LFI-PST-MA-002	1.0	Planck SCS User Manual
RD-03	PL-LFI-OAT-SP-005	1.0	LFI DPC HW Design & Implementation Plan
RD-04	PL-LFI-OAT-IC-001		ICD_030 DPC-DPC Timelines Exchange
RD-05	PGS-ICD-025		DPC-PSO: Instrument Health Reports



3. SYSTEM OVERVIEW

3.1. *The Planck Sorption Cooler System*

The Planck Sorption Cooler System (SCS) is a closed-cycle continuous cryocooler designed to provide >1 Watt of heat lift at a temperature of <20K using isenthalpic expansion of hydrogen through a Joule-Thompson valve (J-T). Some of this heat lift will be provided to cool the Low-Frequency Instrument (LFI) onboard the Planck spacecraft. The remaining heat lift will be used as a pre-cooling stage for two further cryogenic refrigerators (He J-T cooler to 4K; Dilution cooler to 0.1K) that will in turn maintain the High-Frequency Instrument (HFI) at 100mK.

The sorption cooler performs a simple thermodynamic cycle based on hydrogen compression, gas pre-cooling by three passive radiators, further cooling due to the heat recovery by the cold low pressure gas stream, expansion through a J-T expansion valve and evaporation at the cold stage. A schematic of the Planck Sorption Cooler System (SCS) is shown in Fig. 3-1.

The Sorption Cooler System is composed of the Thermo-Mechanical Unit (TMU), the Sorption Cooler Electronics (SCE) and the internal harness.

The TMU is the closed fluid circuit that, circulating H₂, produces the required cooling. It is composed by the Sorption Cooler Compressor (SCC) and the Piping and Cold End (PACE) that can be split into two subsections, the Piping (SCP) and the Cold End (SCCE): a schematic of the TMU is shown in Fig. 3-1. The TMU also includes all the sensors and heaters needed for control and monitoring.

The SCE is the hardware/software system that allows TMU operation, control and monitoring. It is the "interface" between the TMU and the Operator.

Two complete SC Systems (TMU + SCE, Nominal and Redundant) are present onboard the Spacecraft in order to provide full redundancy during the 18-month mission. For the purposes of the SCS Operation Plan they can be considered practically identical. All the information, procedures and operations described in this Manual apply equally to both Units unless specifically mentioned.

The SCC and PACE in each of the nominal and redundant coolers forms an all-welded, principally stainless steel assembly of fluid loop components which, with associated permanently installed wiring and adapter brackets, is handled and installed as a single, non-separable unit.

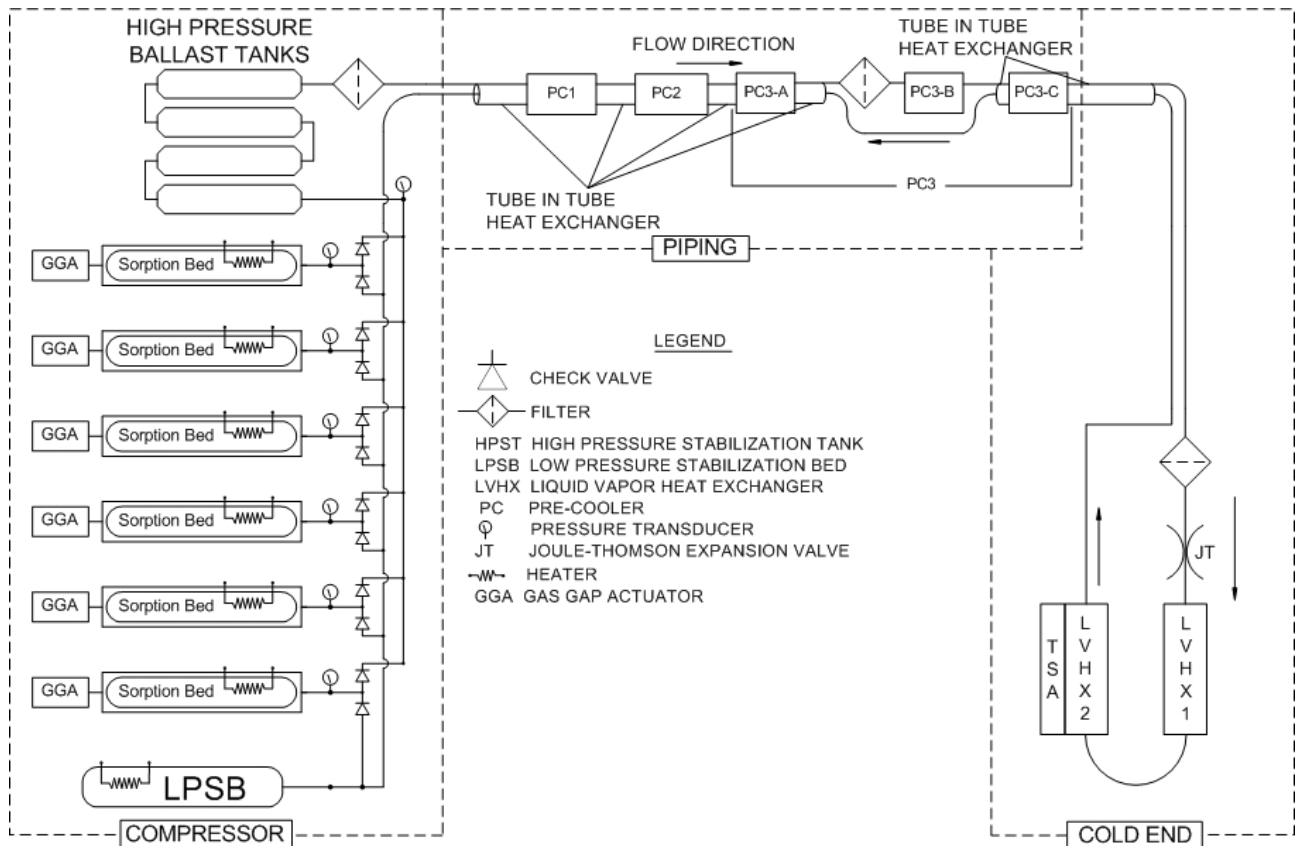

Figure 3-1 TMU schematic

3.1.1. THE SORPTION COOLER COMPRESSOR (SCC)

- Stores the H₂ gas
- Generates the high-pressure gas to be expanded in the Cold End
- Absorbs the returning low-pressure gas
- Stabilizes P fluctuations in both gas lines

3.1.2. THE SORPTION COOLER PACE

- Conveys hydrogen gas to and from the cold end
- Pre-cools the H₂ by tube-in-tube heat exchangers and thermal contact with passive radiators
- Expands the gas to form liquid
- Stores the liquid in reservoirs to provide a T reference for the Instruments
- Stabilizes by an active controller the T at the LFI I/F



3.1.3. THE SORPTION COOLER ELECTRONICS (SCE)

- Controls the TMU by
 - switching control for the sorption bed heaters
 - switching control to the heat switches
 - timing signals for the switching
 - controlling of power to the compressor elements in the “desorbing” state
 - controlling the T of the Temperature Stabilization Assembly (TSA) in the PACE.
- Detect abnormal situations and react
- Read temperature, voltage and intensity sensors from sorption cooler electronic.
- Receive commands from CDMU sent by users from ground
- Send housekeeping data to CDMU that will be transmitted to ground by telemetry.

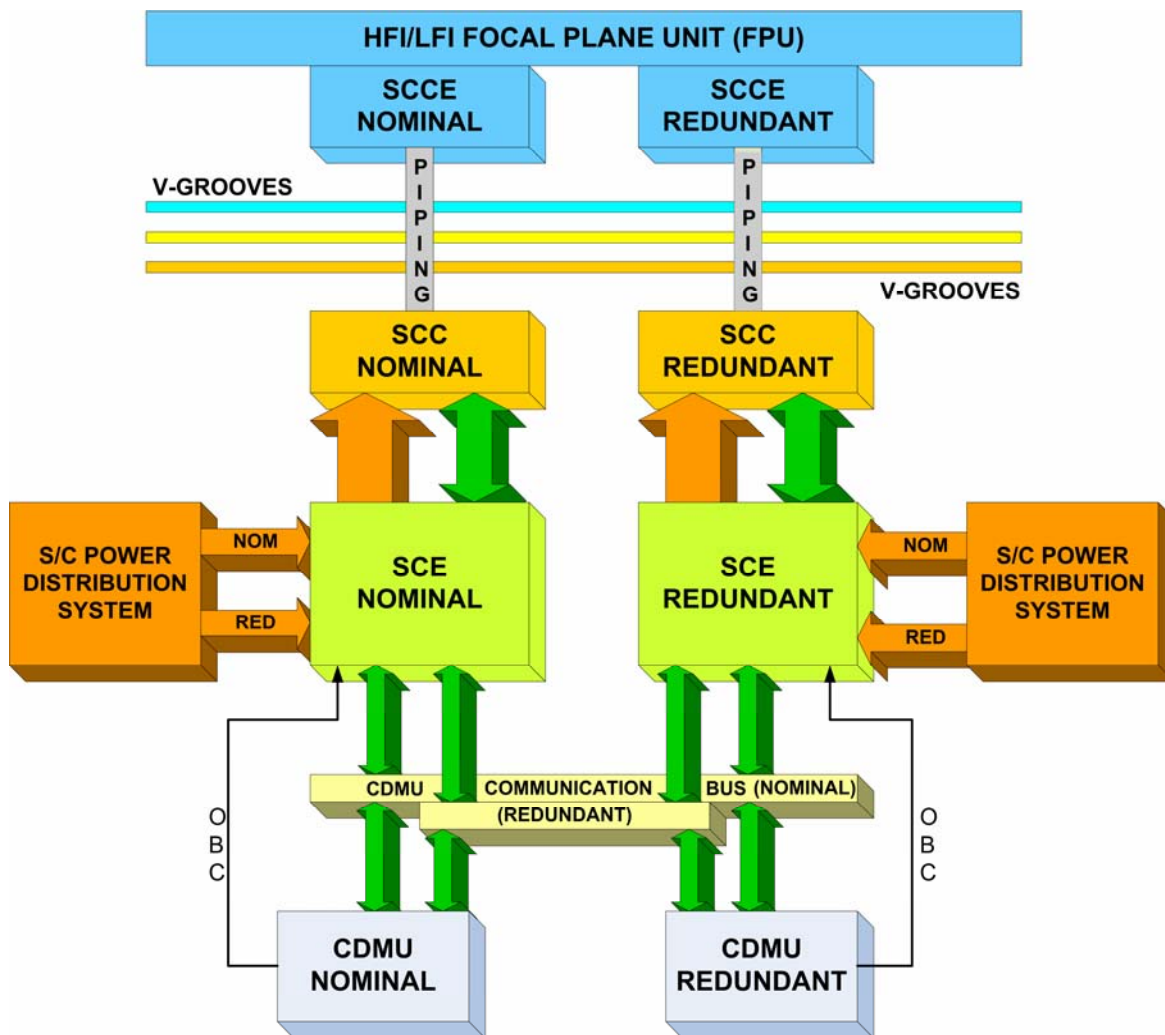

Figure 3-2 Planck SCS (TMU+SCE) Block Diagram



Data are received, processed and released to the S/C through the CDMS buses (Nominal and Redundant). The interface with the spacecraft will be able to handle a baseline data rate of 2 kbit/s and will be compliant with the MIL-STD-1553B standard, with the SCE acting as a remote terminal and the CDMS as the bus controller.

3.2. SCS OPERATION MODES

Figure 3-3 illustrates the whole diagram of the SCS Operation Modes and the possible transitions between them.

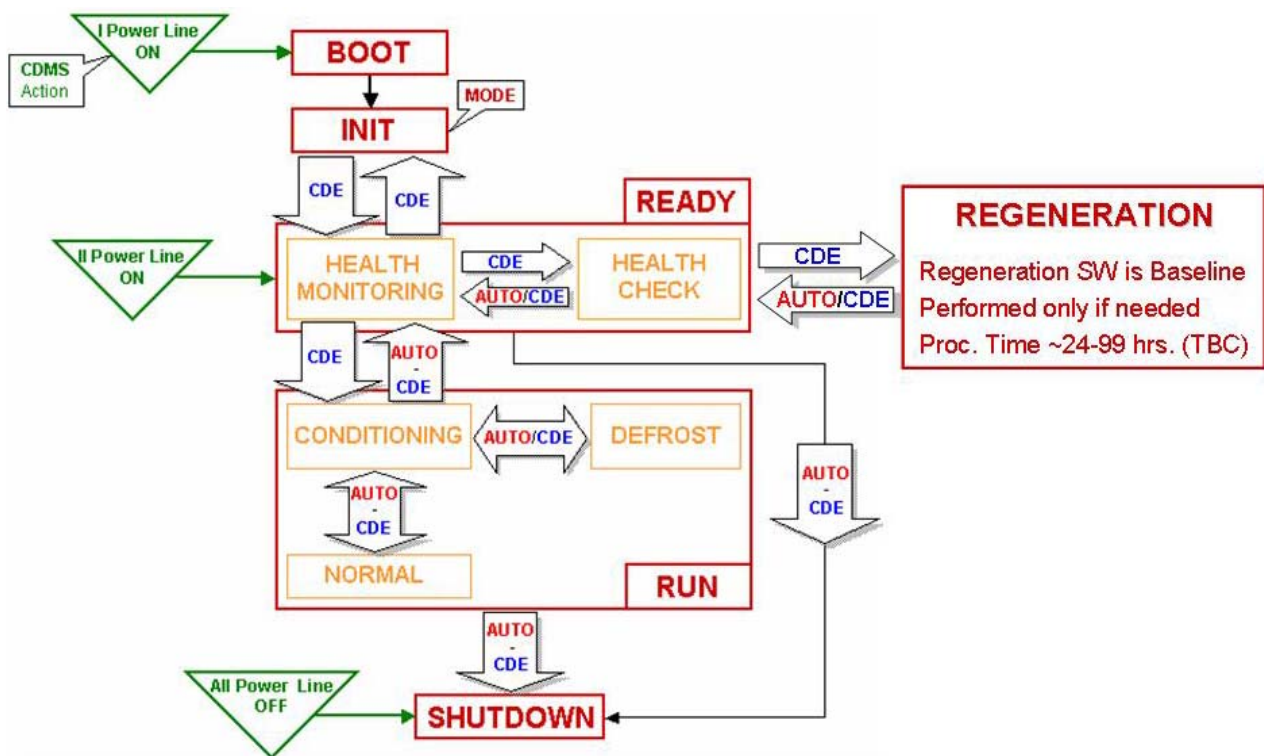

Figure 3-3 Cooler Operations Diagram

The table below shows the **status** of the Sorption Cooler Subsystem units in the main modes of operation. Details of each Mode are listed in Table 3-2.



Unit	Launch or OFF	Boot	Init	Ready		Run			Shutdown
				Health Monitoring	Health Check	Start-up	Defrost	Normal	
TMU	OFF	OFF	OFF	ON	ON	ON	ON	ON	OFF
SCE	OFF	ON	ON	ON	ON	ON	ON	ON	ON
HK	NO	YES	YES	YES	YES	YES	YES	YES	YES

Table 3-1 Status of SCS subsystems in Op Modes

Notes:

- 1) ON= Operational;
- 2) OFF= Inactive;
- 3) *Reminder: There is no mode of operation in which units of both the Nominal and Redundant Sorption Cooler Subsystem operates simultaneously.*



Planck LFI
Sorption Cooler System
Operation Plan

Document No.: PL-LFI-PST-PL-011
 Annex I
 Issue/Rev. No.: 1.0
 Date: July 2008

MODES	STATES	OPERATIONS	COMMANDS
OFF	OFF	None: System can be handled and transported safely	
BOOT		Perform system boot up	ARE YOU ALIVE
		Initialize 1553	GOTO BOOT
		Acquire CDMS Command/Telemetry clock and timing signal	GOTO INIT
		Check PROM, RAM and EPROM	MEMORY UPLOAD
		Transfer Program from EPROM to RAM	MEMORY DUMP
		Check Software Transfer	
		One housekeeping at the end (Electronics and Software parameters)	
INIT		Soft reboot of the System	ARE YOU ALIVE
		Re-initialize 1553	GOTO INIT
		Housekeeping (Electronics and Software parameters)	GOTO READY
			SET INITIAL CE STATE
			MEMORY UPLOAD
			MEMORY DUMP
READY	Health Monitoring	The 2nd power line is requested from the CDMS	ARE YOU ALIVE
		Health Monitoring is automatically performed when enters READY Mode	GOTO INIT
		Check if P and T sensors are correct. Bad sensors are removed from Health Check	GOTO READY
	Healthcheck	Check Compressor Assembly and Cold End by performing actions	GOTO SHUTDOWN
		Bed hydrides are heated up to high temperature to restore the ab/de-sorbing capacity	GOTO HEALTHCHECK
	Regeneration		GOTO REGENERATION
			SET INITIAL CE STATE
			MEMORY UPLOAD
			MEMORY DUMP



RUN	Conditioning	Executed each time the cooler is starting up or is trying to solve some faults before transitioning to Normal State	GOTO READY
		Jump to this State automatically when enters in RUN Mode	GOTO RUN
		Able to run with 6, 5 and 4 beds	GOTO SHUTDOWN
	Defrost	JT and Particle Filter heaters ON for a certain time or until a certain T	MEMORY UPLOAD
		If necessary Defrost is launched automatically from Conditioning	MEMORY DUMP
	Normal Operations	Normal Ops. Beds are powered following the defined sequence	
		Initiation of Normal Ops State is allowed only after one cycle into Conditioning State is completed	
		Each State of the RUN Mode is operated for an integer number of cycle ≥ 1 . Fractional cycles are precluded except for critical emergency response. Can exit during mid-cycle to Conditioning State	
		Able to run with 6, 5 and 4 beds	
		LR3 PID + OPEN LOOP regulation every second (1Hz)	
SHUTDOWN		READY-like Mode with GGA OFF, bed heaters OFF, LR3 OFF, etc.	
		Cooling is stopped, cooler's return to ambient conditions is monitored via housekeeping data	
		When P's return to ambient limits, the CDMS is requested to remove the 2nd Power Line	
		When T's return to ambient limits, the CDMS is requested to remove 1st Power Line	
		Receive/Acknowledge software/values patching instructions (lookup table, etc.)	
		Control and Monitor heated beds cool-down	
		Monitor System and Report Alarm/Fault Conditions	
		High data rate housekeeping	
		System Monitoring executed for TBD min. After SHUTDOWN	
	End of SHUTDOWN Mode corresponds to READY Mode with Power Lines OFF		

Table 3-2 SCS Op Modes processes and actions list



4. OPERATION PROCESSES

4.1. INFRASTRUCTURE

4.1.1. SOFTWARE

4.1.1.1. Data transfer (Between DPC's and to PSO)

File transfer format and protocol for SCS activities fully complies with the LFI DPC patterns.

SCS Daily Quality Report and Weekly Health Reports (DQR and WHR) data file transfers will be ASCII format using the FTP-based Herschel-Planck File Transfer System (HPFTS).

Data file transfers between the two DPC's will be based on FITS format, with predefined keyword as defined in [RD-14] Planck IDIS DMC Exchange Format Design Document and according to the procedures defined in [RD-05] ICD38.

4.1.1.2. DPC SOFTWARE

SCS software is part of LFI DPC Level 1 only and is implemented on Linux platform. SCS HK processing is required for system health and performance evaluation. Data analysis information are made available to the instruments for scientific data reduction (Level 2 and 3) and to PSO. SCS Level 1 activities are also required to use HKTM for trend analysis.

4.1.1.3. INSTRUMENT WORKSTATIONS AT MOC (IW@MOC)

MOC will feed housekeeping TM data to the SCS IW@MOC for Real-Time Analysis (RTA) and Quick Look Assessment (QLA). Basically, the IW@MOC provides a dedicated instrument telemetry processing environment greatly enhancing the capabilities of the SCOS-2K. This platform will basically be running a simplified version of the DPC Level 1 software. It will not provide any commanding capability.

The SCS IW@MOC is assumed to be remotely accessible from LFI DPC through network connection, fulfilling all security constraints set by ESOC. During commissioning the SCS IOT operating the IW@MOC will be the reference for all cooler operations. From CPV Phase throughout the mission except for contingency situations, this function will be sustained by the SCS IOT at the LFI DPC, where a SCS dedicated workstation will be resident. The SCS IW located at MOC will be retained for the whole duration of the mission.

No maintenance activities will be required by MOC personnel except for basic functioning of the machine (reboot, etc).



4.1.1.4. ARCHIVE

SCS TM storage is implemented in the following archives:

- ▶ Raw Telemetry Archive
- ▶ Unscrambled Telemetry Archive
- ▶ Calibrated TOI Archive

4.1.2. HARDWARE

The SCS hardware at the DPC will be based on the same kind of LFI Intel based PC's.

4.1.3. INTERFACES

The interfaces between the LFI DPC and MOC, PSO and the HFI DPC are described in details in dedicated ICD documents and are summarized in Chapter 4 of the LFI Operation Plan [RD-1].

4.2. MANAGEMENT

The LFI management structure is shown in the LFI Operation Plan [RD-1].

The SCS IOT is a section of the LFI Operation Team, located at the LFI DPC. The SCS Operation Manager (OM) is responsible for all related SCS activities and operations. SCS OM interfaces to HFI DPC, MOC and PSO through the LFI OM.

4.3. STAFFING

During Commissioning and CPV phases, part of SCS IOT staff will be located at the MOC, with LFI DPC assistance, 7 days/week to support real-time interaction with the spacecraft. At the same time, SCS personnel at the LFI DPC will be staffed 12 hours/day, 7 days/week, working shifts. In addition, telephonic availability of qualified personnel in case of contingencies will be required.

During Normal Operations the SCS IOT will be staffed 6 days/week, 8 hours/day, 5 hours on Saturdays. Telephonic availability of qualified personnel will be required for 12 hours/day and 7 days/week for the whole duration of Planck operations. The SCS IOM (or deputy), the single contact point, will be available 24 hours/day throughout the mission in case of contingency need by MOC concerning SCS operation.

During Post-operations only a reduced SCS IOT will be present at the LFI DPC, staffed 8 hours/day, 5 days/week.

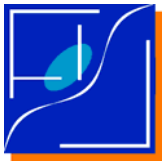

4.4. CONTACT INFORMATION

SCS operations require continuous interaction with other Planck Scientific Ground Segment units (MOC, PSO and the HFI DPC/IOT).

The basic concepts for SCS activities interfaces are:

- ▶ A single contact point, the SCS IOM, will be the reference for all SCS related issues, through the LFI IOM, for LFI DPC, HFI DPC, MOC and PSO.
- ▶ Interaction processes are defined and regulated in the dedicated ICD's



5. OPERATIONS CONTEXT

The SCS main operational task is to provide a stable temperature reference to the HFI and LFI throughout the mission, operating the cooler in a safe state while ensuring optimized performance.

For all data analysis purposes SCS TM is considered HK.

All SCS activities at LFI DPC are part of the Level 1 only (see Figure 5.1).

In general, the SCS IOT supports the LFI IOT and DPC for all SCS related issues and is responsible for:

- SCS operations definition
- SCS operating procedures implementation
- Daily analysis of SCS health
- Daily analysis of SCS performance
- Strategy for SCS performance optimisation
- Software maintenance and update
- Support to the MOC for SCS related issues
- Support to LFI (and HFI) DPC for SCS data analysis
- Release of DQR and WHR

All the above mentioned activities are carried on in collaboration with the LFI IOT and DPC and have to be agreed with or reported to the HFI DPC, MOC and PSO. In particular, SCS operating procedures have to be agreed by the HFI DPC and PSO since they might have an impact on hardware and scientific data.

As part of the LFI DPC, the SCS IOT fulfils all the requirements defined in the in the Planck SIRD when they apply, following the processes described in the LFI Science Operations Implementation Plan (SIP) [AD-9].

SCS Level 1 product will be the cooler parameters TOD. These will be made available for next levels of scientific data analysis or simulations activities. Considerable amount of feedback between all parties involved will be required.

A cross-check with LFI and HFI HK data will be necessary in order to improve confidence on analysis results. SCS and 4K cooler data will be exchanged daily between the two DPC's [RD-04] and [RD-05]; availability of LFI and HFI thermal sensors HK will be required.

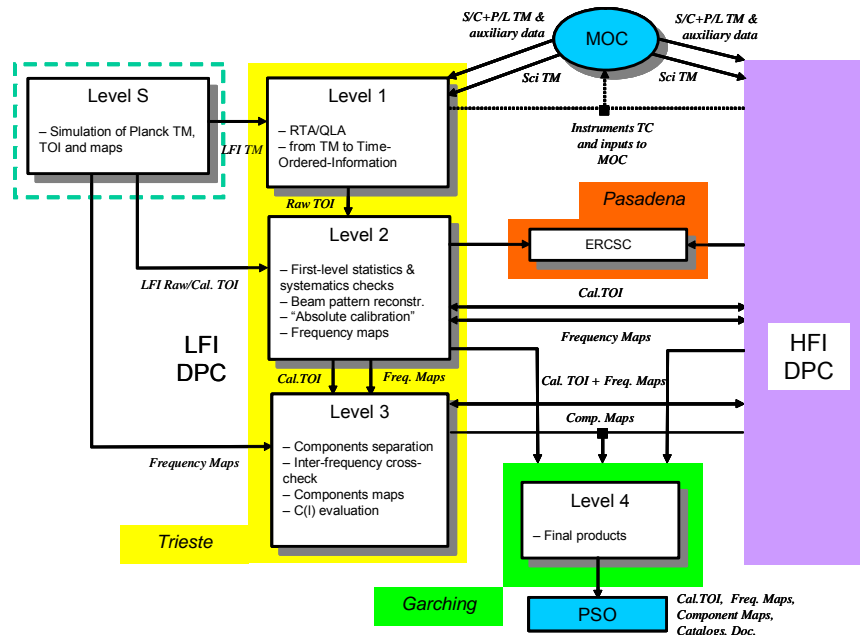

Figure 5-1 Layout of the LFI DPC.

5.1. DATA PROCESSING AND MONITORING

5.1.1. ROUTINE ACTIVITIES

In this paragraph, SCS routine activities are summarized. For their integration with the LFI DPC general activities see the LFI Operation Plan [RD-1]. Scenarios make reference to the DPC data processing design and to the software subsystems described in the LFI DPC Data Processing Document [RD-6].

For what concerns the data processing and monitoring, SCS Routine Activities include:

- Monitoring of SCS telemetry to verify cooler health on a daily basis, including the Level 1 activities (see Figure 5-2). This task is under SCS IOT responsibility with support by the LFI DPC Operations staff
- Monitoring of SCS TM to evaluate cooler performances
- Assessment of performance trend in order to prepare or consolidate operational scenarios (this activity will be carried out on a several weeks/months timescale)

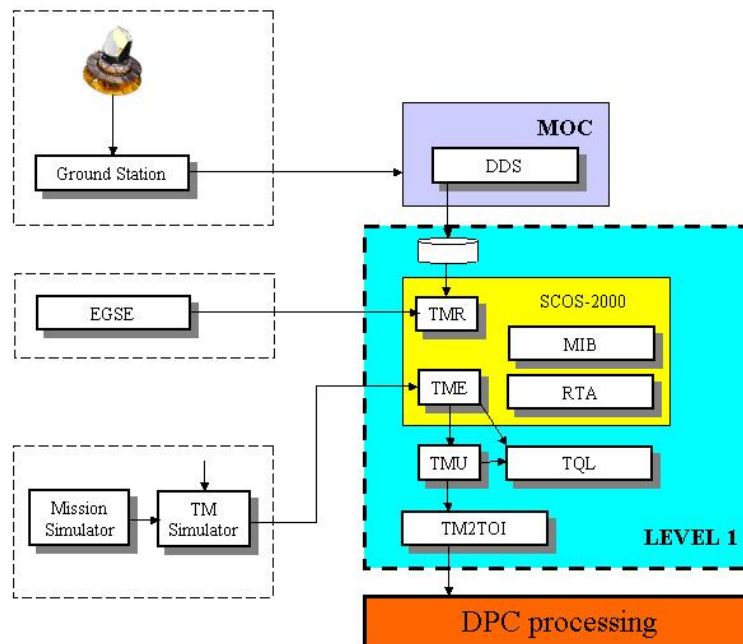

Figure 5-2 Planck LFI Level 1 Data and Software Flow Scheme

5.1.2. COMMISSIONING AND CPV OPERATIONS

During Commissioning and CPV phases the SCS IOT will be partially located at MOC. SCS Commissioning is aimed to prepare the system for start-up while CPV task is to take the cooler down to operating temperature and into Nominal and steady state operations. From the SCS point of view, CPV phase activities after cooldown are not different from routine operations. Only difference might be the higher frequency of tuning steps required to take the cooler in Nominal Mode.

5.1.2.1. COMMISSIONING OPERATIONS

Commissioning of the SCS consist of system switch-on (power lines activation) and the verification of its health by the “HealthCheck” procedure. This process can be done at any time during the mission and in any thermal conditions (warm or cryo). The successful completion of the procedure insures that the system is in good health and ready to be started as soon as the required boundary thermal conditions are reached. The procedure is fully automatic and its parameters are defined in the LUT. The HK TM to be processed is exactly the same of system monitoring in nominal operations. A detailed description of SCS Healthcheck procedure can be found in the SCS UM [RD-2].

SCS Commissioning Operations end at the beginning of cooler cooldown, when its CPV phase starts.

5.1.2.2. CPV OPERATIONS

The CPV Phase is dedicated to the calibration and verification of the instruments, so the SCS operations in this phase are dedicated to cooler start-up and tuning to lead it into the best stable conditions needed for instruments verification. During this phase, extended monitoring of the



system might be required and HK data should be processed in quasi real time to rapidly converge to stable conditions.

Basically, for what concerns the SCS, CPV operations do not differ from Routine operations: with the exception of few, dedicated tests performed at the beginning of the phase, the cooler will be tuned and run in the same operative envelope of the Nominal phase of the mission.

5.1.3. CONTINGENCY ACTIVITIES

In case of contingencies occurrence, as in Routine operations, the system is robust enough to react with the proper response according to the severity of the discrepancy: this automatic action can go from a simple red flag raised to the operator to a system shutdown in case safety limits are passed.

The event of such occurrence will be notified in TM and proper action will be requested from ground after cooler autonomous reaction.

For a complete description of SCS failure analysis, see Chapter 7 of SCS User Manual [RD-2].

5.1.4. NON-ROUTINE ACTIVITIES

Non-routine operations include:

- SCS switchover
- SCS regeneration

5.2. INSTRUMENT TELE-COMMANDING

The SCS IOT team is in charge of provide the MOC with the TC's required to safely and correctly operate the SCS. Each TC sequence should be ready for upload before the next DTCP.

In the Routine Phase, this process will be based on the ICR (Instrument Commanding Request) that will be circulated by email.

In Commissioning or CPV phases, detailed timeline will be prepared in advance and will provide the main reference for execution of activities.

5.2.1. ROUTINE OPERATIONS

SCS routine operations basically consist of TM analysis (SCS health and performance), data quality check, data cross-check (with LFI thermal sensors and HFI 4K cooler TM) and cooler tuning to ensure optimized performance throughout all the mission. For this reason, the only TC's expected to be executed during routine operations are the periodical (baseline is weekly) LookUpTable upload, by dedicated TC.

The procedures for this activity are summarized in Chapter 7.



SCS tuning is performed only by updating and uploading the LUT control values by the following dedicated TC's:

TC Name	TC Description
SC501530	TC 6_2 Load LUT Software – FM1, FM2, PFM1 and PFM2
SC502559	TC 6_2 Load LUT Powers and Times – FM1, FM2, PFM1 and PFM2
SC503559	TC 6_2 Load LUT health Check and Regeneration – FM2
SC504559	TC 6_2 Load LUT Run Mode transitions – FM2
SC505559	TC 6_2 Load LUT Fault Conditions and Bad Bed Detection – FM2
SC506559	TC 6_2 Load LUT PID and Open Loop Algorithms – FM2
SC507559	TC 6_2 Load LUT Heaters Resistances – FM1, FM2, PFM1 and PFM2
SC508530	TC 6_2 Load LUT Calibrations 1 – FM1, FM2, PFM1 and PFM2
SC509530	TC 6_2 Load LUT Calibrations 2 – FM1, FM2, PFM1 and PFM2
SC510559	TC 6_2 Load LUT health Check and Regeneration – FM1
SC511559	TC 6_2 Load LUT Run Mode transitions – FM1
SC512559	TC 6_2 Load LUT Fault Conditions and Bad Bed Detection – FM1
SC513559	TC 6_2 Load LUT PID and Open Loop Algorithms – FM1
SC514559	TC 6_2 Load LUT health Check and Regeneration – PFM2
SC515559	TC 6_2 Load LUT Run Mode transitions – PFM2x
SC516559	TC 6_2 Load LUT Fault Conditions and Bad Bed Detection – PFM2
SC517559	TC 6_2 Load LUT PID and Open Loop Algorithms – PFM2
SC518559	TC 6_2 Load LUT health Check and Regeneration – PFM1
SC519559	TC 6_2 Load LUT Run Mode transitions – PFM1
SC520559	TC 6_2 Load LUT Fault Conditions and Bad Bed Detection – PFM1
SC521559	TC 6_2 Load LUT PID and Open Loop Algorithms – PFM1

5.2.1.1. COMPRESSOR TUNING

In order to achieve best performance, the compressor should be tuned. Parameters like Heatup and Desorption Power, cycle time, LPSB power, gas-gap actuators timing can be adjusted to control required heat lift, insure limited pressure fluctuations and maximise cooler lifetime.

This tuning process will be performed at the beginning of cooler operations, in CPV phase, and in any other situation that could present an unbalance of the reached thermal conditions of the whole cryogenic chain.

During one sky survey a constant cycle time will be maintained, in order to simplify Planck scientific data reduction. The slow degradation of compressor capacity with time will be taken into account by adjusting input power. This tuning will be performed on the basis of the degradation capacity trend that will be continuously assessed during the cooler data analysis. Before the cooler capacity can fall below the required cooling power, the input power will be incremented to oppose this degradation. Baseline for typical time scale of this adjustment will be weekly.



5.2.1.2. COLD END TUNING

One of the most important requirements of the SCS is the temperature stability of the cold end. This is achieved not only by proper compressor tuning but also by taking advantage of the Temperature Stabilization Assembly (TSA) inserted between LVHX2 and the LFI main frame. The TSA is an actively controlled stage that can be operated on the basis of a PID control and/or open loop response. To perform the tuning, the parameters of the control stage, T set point and gains, have to be properly tuned to insure required stability.

The tuning will be operated at the beginning of cooler operations and will be repeated only in case of thermal conditions change.

TSA tuning is performed by updating and uploading the LUT control values.

5.2.2. NON-ROUTINE OPERATIONS

SCS Non-routine operations consist of:

- Cooler Switch-over
- Regeneration

5.2.2.1. COOLER SWITCH-OVER

This procedure is used to deactivate the working unit and to start the “sleeping” one. Such process will be used not only to transition between the two units (Nominal and Redundant), if needed, in case of failure but also as a tool to optimise both cooler lifetime ensuring maximised mission duration. Obviously, system switchover will be planned in advance according to cooler performance and mission constraints.

The general sequence for SCS switchover can be summarized in the following steps:

- Switch OFF LFI (4K cooler and Dilution stay ON, TBC)
- Shutdown SCS Nominal
- Initialise SCS Redundant
- GOTO READY MODE, enter Health Monitoring
- GOTO RUN MODE
- Wait for SCS R to enter Nominal Operations
- Perform cooler tuning

The whole procedure, can take up to 2 - 3 hrs (TBC), is detailed in the SCS UM [RD-2]

5.2.2.2. REGENERATION

Regeneration process is used to restore SCS bed hydrides ab/de-sorption capacity. By taking the compressor elements to very high temperatures it is possible to recover up to more than 90% of their BOL capacity. The execution of regeneration is not considered as baseline but only as a possible tool to extend cooler, and mission, lifetime.



The procedure is fully automatic and it is started by TC "GOTO Regeneration". The system, at the end of the sequence, automatically returns into READY Mode - Health Monitor. It is also possible to interrupt this process forcing the system to go back to READY by TC. Regeneration process is described in the SCS User Manual.

5.2.3. COMMISSIONING AND CPV OPERATIONS

As already mentioned, an operational timeline for Commissioning and CPV phases can not be foreseen at present since the operation sequence at S/C level has not been defined yet.

5.2.3.1. COMMISSIONING OPERATIONS

SCS Commissioning Operations include:

- SCS-Nom unit activation
- SCS-Nom unit initialization
- SCS-Nom unit in READY Mode
- SCS-Nom unit in Healthcheck
- SCS-Nom unit switch-off
- SCS-Red unit activation
- SCS-Red unit initialization
- SCS-Red unit in READY Mode
- SCS-Red unit in Healthcheck
- SCS-Red ready to be started

5.2.3.2. CPV OPERATIONS

SCS CPV planned operations are:

- Start-up of SCS-Red
- SCS-Red enters NOMINAL Mode
- Perform Cooler and TSA tuning
- ...Instruments CPV...
- Switch-over from Red to Nom
- Start-up of SCS-Nom
- SCS-Nom enters NOMINAL Mode
- Perform Cooler and TSA tuning



- SCS-Nom ready for first sky survey

5.2.4. CONTINGENCY ACTIVITIES

With “Contingency Activities” sheet are indicated all those activities that are requested in response to a system anomaly or degraded performance. They can be divided in two main categories:

1. unexpected events (such as failures or malfunctions) that require both on board autonomous recovery and ground reactions
2. “planned” recovery actions to react to system typical degradation with lifetime. Such actions are scheduled in advance in particular mission phases in order to minimize impact on observations.

In the second group, cooler switchover and regeneration are the two expected processes.

In case of anomaly detection on the SCS, on board SW is able to autonomously react to different contingency situations. Nevertheless, after the on-board automatic anomaly detection and response, immediate action will be needed from ground. If needed a NCR will be raised and the typical chain of NRB’s and meetings will be triggered by the SCS OM, or the deputy, that will also involve in the required specialists in the investigation.

5.3. SOFTWARE MAINTENANCE

The SCS software maintenance will be executed according to the general LFI DPC SW maintenance procedures (see [RD-1]).

5.3.1. NEW SOFTWARE RELEASE

SCS activities are part of SGS1 only. SCS HW and SW at DPC are cloned in two redundant identical copies under configuration control. In case of new software release, the code is first verified on the redundant unit and then installed on the nominal HW.

5.3.2. END OF SURVEY

Additional operations at the end of survey will be needed for final cooler data analysis: a general assessment of SCS performance, degradation and behaviour during the survey will be provided.

SCS IOT resources will mainly be required to support scientific data analysis for evaluating the impact and the possible removal techniques of cooler effects and thermal systematics on science.

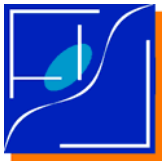

5.4. ARCHIVE DEVELOPMENT

LFI DPC data archiving is based on Oracle system and is divided in two main archives: one for SGS1 and one for SGS2. SCS data will obviously be stored in the SGS1 archive and mirrored for fast recovery in case of problems. For details, see LFI Operation Plan [RD-1].



6. NOMINAL OPERATIONS

This paragraph summarizes all SCS nominal operations.
Description and details of procedures are reported in Chapter 7.

6.1. SCS ROUTINE PHASE SHEETS

6.1.1. SCS DAILY OPERATIONS SHEET

Daily operations include the following procedures (see Chapter 7):

1. Download one observation day of consolidated SCS and eventually related S/C or HFI TM (from HPDDS at MOC)
2. Run Level 1 software (see Figure 5-2):
 - Real Time Assessment – RTA;
 - Telemetry Quick Look – TQL;
 - TeleMetry Handling - TMH (TMU + TM2TOI) to expand/convert the telemetry and complement with auxiliary information.
3. Check SCS TM parameters of last OD:
 - Verify State Vector: cycle time, HU & DE Power, GGA delay/advance, LPSB Power, TSA set-point & power, Gas-Gap Actuators Current
 - Check Boundary Conditions: I/F compressor beds T, V-Grooves T
 - SCS Monitor: compressor beds T's and P's, High Pressure Line , Low Pressure Line, LPSB T, LVHX's T, TSA T
 - SC Electronics: V28, V15, V5, SCE panels T, 28 V line Current
4. Compute SCS Performance: mass flow & heat lift, LVHX's absolute T drift, peak to peak T fluctuations and their frequency spectrum
5. Evaluate Data Quality: check presence of glitches or instabilities
6. Comparison with HFI (4k Cooler) and LFI (FPU T sensors) data for cross-checking:
 - Check LFI HK TM
 - Retrieve data from HFI data storage
7. Compile the reports generated by LIFE (for LFI) and SCS Analysis dedicated software into a Daily Quality Report (DQR) to be sent to PSO
8. Organize the daily meeting for SCS related issues: in routine operations it will be part of LFI daily meeting.



6.1.2. WEEKLY OPERATIONS SHEET

Weekly operations include the following procedures (see Chapter 7):

1. Read one week of SCS data from archive
2. Run SCS Analysis dedicated SW for data checking and analysis. Compute trend analysis of:
 - High Pressure line
 - Heat lift
 - Low Pressure line
 - Cold End T's
 - Cold End T peak to peak fluctuations
 - Cold End T frequency spectrum
3. Evaluate long term cooler performance in terms of system degradation and remaining lifetime. Expected cooler behaviour in next weeks and propose/confirm planned operational activities.
4. Upload new LUT (Look Up Table) parameters for SCS "routine" tuning
5. Compare with LFI and HFI data for cross-checking
6. Compile the reports generated by SCS SW trend analysis and daily reports into a Weekly Health Report (WHR) to be sent to PSO
7. Report in WHR cooler operational parameters (LUT) to be loaded next week for system tuning
8. Organize the weekly meeting for SCS related issues, together with LFI.

A week is nominally starting on Wednesday but eventually it can be shifted to another week day.

6.1.3. MONTHLY OPERATIONS SHEET

Monthly operations include the following procedures (see Chapter 7):

1. Read one month of SCS data from archive
2. Run SCS Analysis dedicated SW for data checking and analysis. Compute trend analysis of:
 - High Pressure line
 - heat lift
 - Low Pressure line
 - Cold End T's



- Cold End T peak to peak fluctuations
 - Cold End T frequency spectrum
3. Evaluate long term cooler performance in terms of system degradation and remaining lifetime. Expected cooler behaviour in next weeks and propose/confirm planned operational activities.
 4. Report cooler operational parameters (Look Up Table) to be loaded next week for system tuning
 5. Compare with LFI and HFI data for cross-checking
 6. Compile the reports generated by SCS SW trend analysis and daily reports into a Weekly Health Report (WHR) to be sent to PSO
 7. Organize the weekly meeting for SCS related issues, together with LFI.

To be consistent with the weekly operations, the month is nominally starting on the first Wednesday of each month but eventually it can be shifted to another week day.

6.2. COMMISSIONING AND CPV OPERATIONS SHEET

During Commissioning and CPV operations, activities are not divided in daily, weekly and monthly as activities performed will be different every day. Commissioning includes all operations needed to evaluate system health and prepare it for start-up. CPV is the mission phase in which the cooler reaches Nominal Mode and its performance are checked and evaluated.

6.2.1. COMMISSIONING OPERATIONS SHEET

From the ground segment point of view, Commissioning activities can be summarized in:

- Online cooler data analysis
- Offline cooler data analysis
- Evaluation of system health
- Verify parameters for cooler start-up
- Collaborate to Commissioning Daily Meeting organization

6.2.2. CPV OPERATIONS

- Online cooler data analysis
- Offline cooler data analysis
- Evaluation of system performance



- Verify parameters for cooler optimization
- Cooler tuning for performance optimization (LUT upload)
- Collaborate to CPV Daily Meeting organization

6.3. NON-ROUTINE OPERATIONS SHEET

6.3.1. CONTINGENCY RESPONSE

As described in Par.5.2.4, in case of contingency, response from ground will be needed to evaluate anomaly and OBSW autonomous actions. After investigation of the problem, according to the anomaly level, it may be required to send TC for:

- uploading a new LUT to adapt to new conditions
- taking the cooler into stand-by operations
- taking the cooler into shutdown
- restarting the cooler after problem solution

6.3.2. COOLER SWITCH-OVER

Switch-over procedure (see SCS UM [RD-2]) will be executed and system will be monitored for health and functionality evaluation.

6.3.3. REGENERATION

Regeneration procedure (see SCS UM [RD-2]) will be executed and system will be monitored for health and functionality evaluation.



7. NOMINAL OPERATION PROCEDURES

The main reference for SCS operating procedures is the SCS User Manual [RD-2].

7.1. COMMISSIONING AND CPV OPERATIONS

7.1.1. REAL TIME HK DATA ANALYSIS

Responsible Person:

SCS Operation Manager and SCS engineers

Estimated Duration:

5 hours (DTCP duration)

Inputs:

HK TM real time data

Outputs:

- System status assessment

Procedures:

Verification that values and TM are within specifications and requirements

Description:

By checking real time HK data produced by the SCS, the evaluation of cooler performance, health and stability will be performed.

7.1.2. OFFLINE DATA ANALYSIS

Responsible Person:

SCS Operation and SCS engineers

Estimated Duration:

Variable, depending on the amount of data or on the particular analysis requested
Automatically started when first chunk of data is downloaded at IW@MOC

Inputs:

Chunks of HK SCS data at IW@MOC.

Outputs:

- System status assessment
- SCS alarms and reports are automatically generated

Procedures:

Refer to TQL, TMH SSD and to the LIFE User Manual references in LFI Operation Plan [RD-1].



Description:

Run TQL on TM packets, verify the performance and the overall health of the SCS.
Run TMH, TMU + TM2TOI, to decompress/expand/convert the HK telemetry.
Run the LIFE system to:

- Check SCS TM parameters of last OD:
 - Verify State Vector: cycle time, HU & DE Power, GGA delay/advance, LPSB Power, TSA set-point & power, Gas-Gap Actuators Current
 - Check Boundary Conditions: I/F compressor beds T, V-Grooves T
 - SCS Monitor: compressor beds T's and P's, High Pressure Line , Low Pressure Line, LPSB T, LVHX's T, TSA T
 - SC Electronics: V28, V15, V5, SCE panels T, 28 V line Current
- Compute SCS Performance: mass flow & heat lift, LVHX's absolute T drift, peak to peak T fluctuations and their frequency spectrum

7.1.3. CROSS-CHECK SCS AND HFI THERMAL DATA

Responsible Person:

SCS Operation and DPC Managers

Estimated Duration:

Variable, depending on the amount of data or on the particular analysis requested

Inputs:

LFI and HFI HK thermal-related converted timelines

Outputs:

Analysis result might be reported in SCS status assessment or on dedicated reports for specific thermal issues.

Procedures:

Run the KST tool to cross-correlate SCS, HFI and LFI data. For data exchange see [RD-4].

Description:

For the general thermal analysis of the Planck PLM, different kinds of data cross-checks could be needed. This will require for flexibility in data handling and analysis.

7.1.4. UPLINK OPERATIONS: CHECK INSTRUMENT PROCEDURE

Responsible Person:

SCS Operation Manager

Estimated Duration:

Dependent on the uplink operations (number of parameters to be changed)



Inputs:

Look Up Tables

Outputs:

Cooler performance and health report

Procedures:

Correct procedures and parameters to be uploaded verification by SCS OM

Description:

All along the duration of commissioning and CPV phases, a number of TPF files should be ready to be uploaded by MOC.

7.1.5. COMMISSIONING AND CPV DAILY MEETING

Responsible Person:

SCS Operation Manager

Estimated Duration:

Less than 1 hour. The meeting is held just before or after the LFI one and starts after the DTCP, as soon as data analysis is completed.

Inputs:

Previous and current status of Commissioning and CPV tests. Results of data analysis for the tests just concluded.

Outputs:

Minutes of the Daily Meeting including possible Action Items assigned.

Procedures:

Organization of the daily meeting

Description:

Organize the daily meeting to discuss the previous OD data analysis and, if needed, the definition of TPF files to be up-linked during next DTCP.

7.2. ROUTINE OPERATIONS

The SCS timeline is integrated in the LFI one and the general scenario is reported in the LFI Operations Plan [RD-1]. The "Mid case" timeline is considered to be the reference, even if the estimated time of each operation might change depending on the real DTCP time.

7.2.1. READ ONE DAY DATA

Responsible Person:

DPC SGS1 Manager



Estimated Duration:

1 hour. Process starts automatically when consolidated data are available at MOC: at about 16:30 CET

Inputs:

Consolidated SCS TM available at MOC

Outputs:

Chunks of SCS data at DPC

Procedures:

Refer to TQL/TMH and HPDDS Software Specification documents (see [RD-1]).

Description:

Download one observation day of consolidated SCS TM from HPDDS and HPFTS at MOC. Additional daily work might be needed for old SCS telemetry retrieval.

7.2.2. REAL TIME ASSESSMENT (RTA)

Responsible Person:

DPC SGS1 Manager

Estimated Duration:

Less than 1 hour. Start when first chunk of data is downloaded at DPC: at about 16:30 CET

Inputs:

Chunks of SCS data at DPC

Outputs:

SCS alarms and logs are automatically generated.

Procedures:

Refer to LFI RTA and SCOS2K User Manual

Description:

Run RTA to detect out-of-range HK TM values to identify suspicious TM.

Alarms and logs are automatically generated.

Note that this operation is independent from the TM handling.

7.2.3. TELEMETRY QUICK LOOK (TQL)

Responsible Person:

DPC SGS1 Manager

Estimated Duration:

Less than 2 hours. Start automatically when first chunk of data is downloaded at DPC: at about 16:30 CET



Inputs:

Chunks of SCS data at DPC: HK, alarms and logs generated by RTA.

Outputs:

Instrument alarms and reports are generated

Procedures:

Refer to TQL Spec document in [RD-1]

Description:

Run TQL on packets to verify suspicious HK TM.

Verify the performance and the overall health of the SCS.

If alarms were generated during RTA session, TQL analysis will focus on anomaly data.

Reports are generated under request.

Note that this operation is independent from the TM handling

7.2.4. TELEMETRY HANDLING (TMH)

Responsible Person:

DPC SGS1 Manager

Estimated Duration:

About 2 hours (data retrieval included)

This process starts automatically when first chunk of data is downloaded at DPC: at about 16:30 CET

Inputs:

Chunks of SCS HK data at DPC

Outputs:

The output is TOI data set of few hundreds of Mb.

- SCS HK TM is time-ordered, covering one whole day and calibrated to engineering values
- SCS TOD are stored

Procedures:

Refer to TMH SSD doc, see [RD-1]

Description:

Run TMH, TMU + TM2TOI, to decompress/expand/convert HK telemetry. HK data are also flagged according to possible predefined occurrences (e.g. Out Of Limits - OOL).

7.2.5. LIFE SYSTEM ANALYSIS

Responsible Person:

DPC SGS1 Manager

Estimated Duration:

Less than 2 hours



Analysis starts automatically when the complete set of OD data and their related auxiliary information will be available at DPC: at about 21:30 CET

Inputs:

SCS HK TOI from DPC

Outputs:

The output is the Daily Quality Report ready to be reviewed before being sent to PSO/MOC/HFI.

Procedures:

Refer to the LIFE User Manual, see reference in [RD-1].

Description:

Run the LIFE system to:

- Report system events and errors, if any
- SCS main Op parameters (Compressor P and T, cold end T, electronics)
- Evaluate SCS mass flow, cooling power, T control stage power
- Calculate average values and fluctuations of above parameters

The results will be automatically included in the Daily Quality Report.

7.2.6. DAILY QUALITY REPORTS

Responsible Person:

SCS OT and DPC Manager

Estimated Duration:

Less than 1 hour. This process follows the LIFE system analysis (see previous paragraph).

Inputs:

Reports generated automatically during LIFE processing

Outputs:

Final Daily Quality Report (DQR).

Procedures:

Run the LIFE module to generate the DQR.

Description:

Compile the reports generated by LIFE into a daily quality report (DQR, see [RD-5]) based on cooler HK data received at the DPCs during that day. SCS DQR is annex to the LFI one.

The report is automatically generated during the LIFE running, it should be checked and sent to PSO, after the daily meeting. The DQR will be ready within 12 (TBC) hours after consolidated data are available at MOC, at about 04:30 CET.

On Sunday the Daily Quality Report will be reviewed on the next day, after the Monday daily meeting. In case no problems resulted from previous steps of analysis (including checks on the "event reports" TM(5,x) or the TM packets production rate), the DQR generated by LIFE will be automatically sent to PSO. After the Monday review the Sunday DQR, or a review in case of discrepancies, will be sent to PSO as an annex to the LFI one.



If a problem is detected, the DPC/IOT person on duty will be in charge of reviewing the DQR as soon as possible in order to understand and possibly solve the problem (see contingency activities described in Par. 5.2.4 and 6.3.1 **Errore. L'origine riferimento non è stata trovata.**). In this case the DQR will not be sent automatically to PSO but it will be sent by the DPC/IOT person on duty after review.

7.2.7. SCS CONVERTED DATA EXPORT VS HFI DPC

Responsible Person:

DPC Manager

Estimated Duration:

About 1 hour

Inputs:

SCS converted data in DMC format

Outputs:

SCS converted data in EFDD format ready to be downloaded by HFI

Procedures:

Ad hoc software

Description:

Export SCS converted data in EFDD format according to the ICD [RD-4].

7.2.8. COMPARISON WITH HFI THERMAL: DOWNLOAD HFI HK DATA

Responsible Person:

DPC Manager

Estimated Duration:

Variable.

Inputs:

HFI converted thermal data available at HFI DPC

Outputs:

HFI converted data at LFI DPC

Procedures:

Run FTP script to download the HFI thermal HK timelines.

Description:

Retrieve converted housekeeping data from HFI data storage as defined in the DPC-DPC ICD [RD-4].



7.2.9. UPLINK OPERATIONS: INSTRUMENT PROCEDURE REQUESTS

Responsible Person:

SCS Operation Manager

Estimated Duration:

Depending on system procedure, see SCS User Manual [RD-2]

Inputs:

Request for the procedure.

Outputs:

ICR ready to be sent to PSO/MOC/HFI with the TC procedure request after the daily meeting.

Procedures:

Prepare Instrument Commanding Request

Description:

Request a cooler procedure to either enhance the performance, improve system monitoring or recover from a contingency. In order to proceed some system parameters need to be changed. In particular:

- SCS input (Heat-up and Desorption) power
- SCS cycle time
- Compressor heat switches timing
- Low Pressure Bed operating point
- Cold End stabilization stage PID parameters or setpoint

All the values to be changed, after approval path, are prepared and checked in advance, filled in a TPF and transmitted to MOC for upload in the next DTCP.

7.2.10. DAILY MEETING

Responsible Person:

DPC Manager

Estimated Duration:

1 hour. To be started at 9 AM (TBC) hour.

Inputs:

Previous and current OD DQR ready, next DTCP Uplink command sequence prepared.

Outputs:

Minutes of the Daily Meeting, DQR transmission to MOC/PSO and uplink command sequence, if any.

Procedures:

To be defined.



Description:

Organize the daily meeting to discuss the previous OD DQR (already sent to PSO), the results of DQR on current OD and the command sequence to be up-linked during next DTCP. It will be organized after the current OD DQR is ready (at about 04:30 CET in the "Mid case"), in the morning, around 09:00 CET. On Saturday the daily meeting will be organized one hour later (TBC) at 10 AM. No meeting is supposed to take place on Sunday.

7.2.11. READ ONE WEEK DATA

Responsible Person:

DPC SGS1 Manager

Estimated Duration:

1 hour

Inputs:

SCS archive at DPC

Outputs:

SCS TOD available for weekly analysis

Procedures:

Read the data form archive

Description:

Read one week of SCS data from archive (around 1 GB).

A week is nominally starting on Wednesday but eventually it can be shifted to another week day.

7.2.12. SCS REDUCED DATA EXPORT VS HFI DPC

Responsible Person:

DPC Manager

Estimated Duration:

Variable, depending on length of TOD file.

Inputs:

SCS reduced data in DMC format (see [RD-4])

Outputs:

SCS reduced data in EFDD format ready to be downloaded by HFI

Procedures:

Ad hoc software

Description:

Export SCS reduced data in EFDD format according to the ICD [RD-4].



7.2.13. WEEKLY HEALTH REPORTS

Responsible Person:

DPC Manager

Estimated Duration:

Less than 2 hours

Inputs:

All Daily Quality Reports and eventually Error Reports of the whole week, Weekly Health Report just produced by LIFE

Outputs:

Final Weekly Health Report

Procedures:

LIFE module to produce the Weekly Health Report

Description:

Combine the reports generated by LIFE trend analysis and daily reports into a Weekly Health Report (WHR) to be sent to PSO/MOC/HFI. As defined in [RD-5], the WHR contains the cooler health status, trend and prediction information, to ensure that the survey performance can be accurately planned and monitored by PSO.

7.2.14. WEEKLY MEETING

Responsible Person:

DPC Manager

Estimated Duration:

1 hour

Inputs:

All Daily Quality Reports, minutes of the Daily meetings, Error Reports of the week, Weekly Health Report, minutes of the last weekly meeting.

Outputs:

Minutes of the Weekly Meeting, WHR sent to PSO/MOC with the LFI one

Procedures:

To be defined

Description:

Organize the weekly meeting on Wednesday morning at about 10 AM, after the daily meeting.



7.2.15. READ ONE MONTH DATA

Responsible Person:

DPC SGS1 Manager

Estimated Duration:

TBD

Inputs:

SCS calibrated TOD archive.

Outputs:

SCS TOD available for trend analysis

Procedures:

Read one month of data

Description:

Read one month of calibrated SCS TOD from TOD archive.

The month is nominally starting on the first Wednesday of each month but eventually it can be shifted to another week day.

7.3. TIMELINE

Timeline sequence is shown in the LFI Operation Plan (see [RD-1]), SCS activities are carried out in the framework of the LFI ones. SCS data, being HK TM, are early available, during the DTCP, from MOC. LFI DPC will download them at the beginning of the Data Transfer (TBC).

7.4. SUMMARY OF ACTIVITIES AND TASKS



8. CONTINGENCY OPERATIONS

8.1. CONTINGENCY REACTION: NCR AND NRB

Responsible Person:
SCS Operation Manager

Estimated Duration:
Process starts right after an anomaly is detected during TM analysis. The duration will depend on the contingency.

Inputs:
Anomaly description

Outputs:
NCR raised, NRB meeting called, specialists informed, contingency solution plan.

Procedures:
Contact specialists (by phone and via e-mail) as soon as possible, raise an NCR, call an NRB meeting (via e-mail). A SCS internal meeting or a tele-conference should be organized to prepare a plan for anomaly investigation and recovery.

Description:
In case of a failure/anomaly or unexpected results, a NCR should be raised and an NRB meeting called. SCS OM or a deputy, always available on call, will contact immediately specialists to analyze and solve the contingency as soon as possible.

8.2. CONTINGENCY REACTION: SCS INTERNAL MEETING

Responsible Person:
SCS Operation Manager

Estimated Duration:
Start immediately after an anomaly occurs. The duration will depend on the contingency

Inputs:
Anomaly description

Outputs:
Plan for contingency investigation and solution.

Procedures:
Organize the meeting with specialists (in person or by phone).

Description:
SCS OM or a deputy, always available on call, contacts specialists and organize a SCS internal meeting to analyze and solve the contingency as soon as possible. This meeting will not



required the presence of LFI IOT members unless involved with the investigation or unless they wish to participate.

8.3. CONTINGENCY REACTION: INSTRUMENT PROCEDURE REQUESTS

Responsible Person:
SCS Operation Manager

Estimated Duration:
Depending on the instrument procedure, see SCS User Manual [RD-2]

Inputs:
Request for the procedure

Outputs:
ICR ready to be sent to PSO/MOC/LFI/HFI with TC procedure request

Procedures:
Write the Instrument Commanding Request

Description:
Request a procedure for quick reaction to the contingency and, after a solution is found, for recovery.