



Rapporti Tecnici INAF INAF Technical Reports

Number	122
Publication Year	2022
Acceptance in OA@INAF	2022-01-25T10:15:39Z
Title	Studio preliminare sulla resistenza strutturale del Gregorian Feed Rotator di SRT
Authors	ATTOLI, ALESSANDRO, MARONGIU, Pasqualino
Affiliation of first author	O.A. Cagliari
Handle	http://hdl.handle.net/20.500.12386/31350 , https://doi.org/10.20371/INAF/TechRep/122

Studio preliminare sulla resistenza
strutturale del
Gregorian Feed Rotator di SRT

Appendice

Alessandro Attoli, Pasqualino Marongiu
INAF - Osservatorio Astronomico di Cagliari

Sommario

Sommario	2
Appendice	2
Allegato 1: DWG_32525_200_09-200	4
Allegato 2: SRT-DWG-32525-200-09-200	6
Allegato 3: SRT-DWG-32522-200-08-200	8
Allegato 4: SRT-DWG-32522-200-08-201-04	10
Allegato 5: SRT-DWG-32522-202-01	11
Allegato 6: SRT-DWG-32522-212-04	12
Allegato 7: SRT-LIS-32522-001-05	13
Allegato 8: SRT-SPE-32525-002-01	16
Allegato 9: SRT-ANA-32525-003-01	26

Appendice

Allegati tecnici

1. Disegno SRT-DWG-32525-200-09-200 Gregorian Assembly Part 1.....pag.
2. Disegno SRT-DWG-32525-200-09-200 Gregorian Assembly Part 2.....pag.
3. Disegno SRT-DWG-32522-200-08-200 Gregorian Positioner From Assembly Part. 1...pag.
4. Disegno SRT-DWG-32522-200-08-201-04 Gregorian Positioner From Assembly Part. 2
5. Disegno SRT-DWG-32522-202-01 Gregorian Positioner Frame Anchorage parts system
6. Disegno SRT-DWG-32522-212-04 Gregorian Positioner Frame Anchorage Points
7. Elenco materiale SRT-LIS-32522-001-05 Gregorian Positioner Frame
8. Documento SRT-SPE-32525-002-01 Techn. Specification for Gregorian Pos. Bearing
9. Documento SRT-ANA-32525-003-01 Gregorian Positioner Bearing Analysis

Allegato 1: DWG_32525_200_09-200

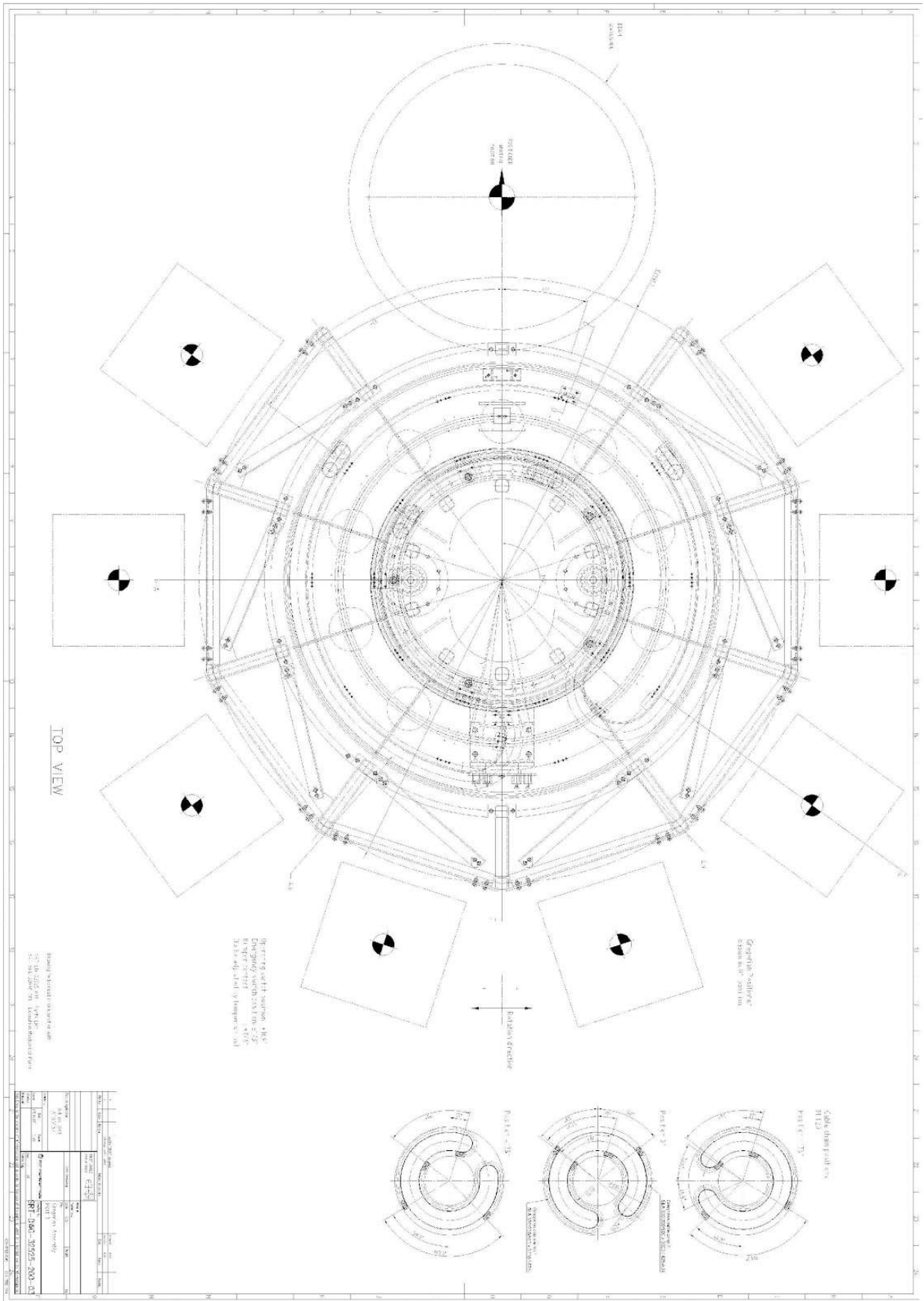

Allegato 2: SRT-DWG-32525-200-09-200

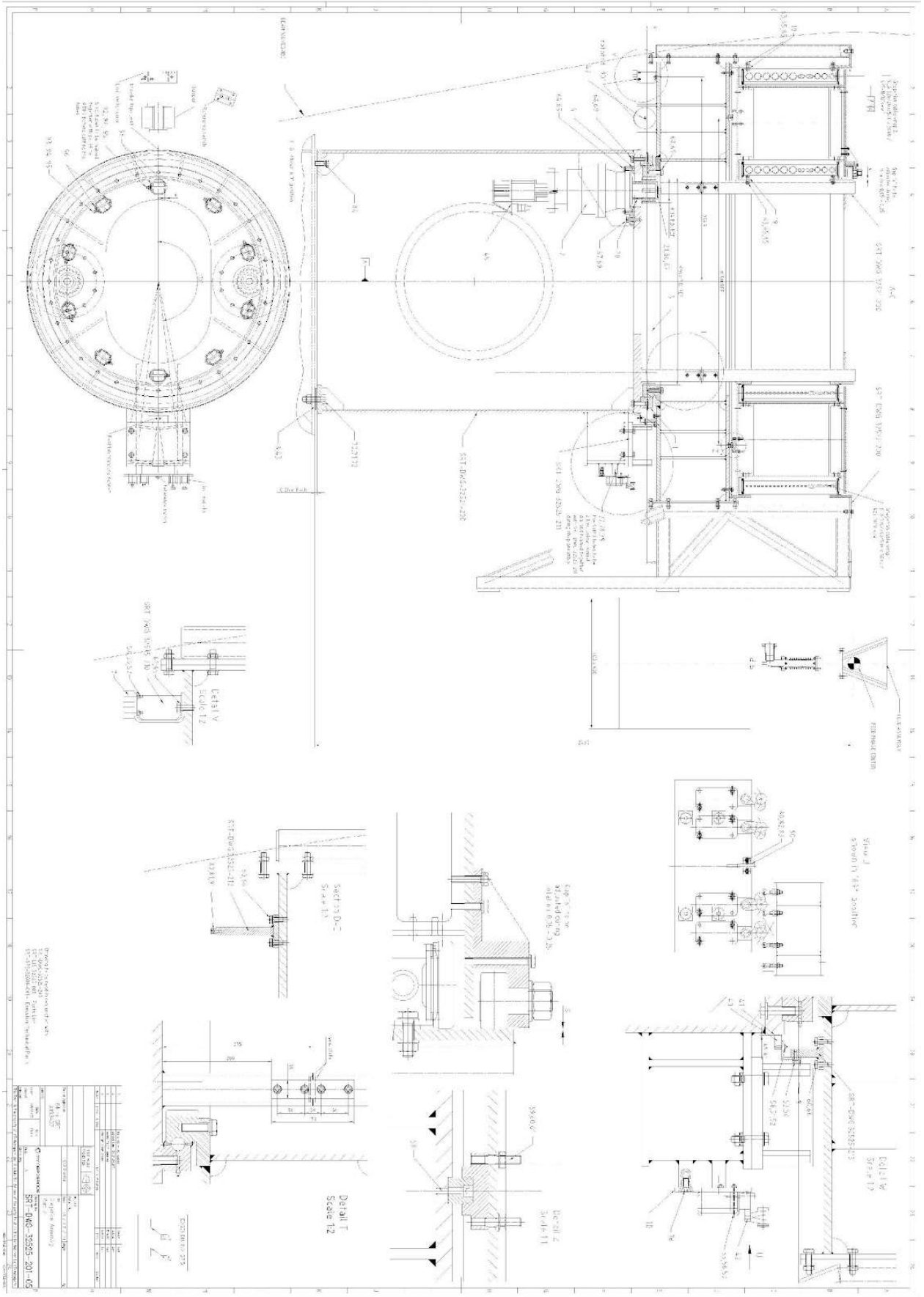

Allegato 3: SRT-DWG-32522-200-08-200

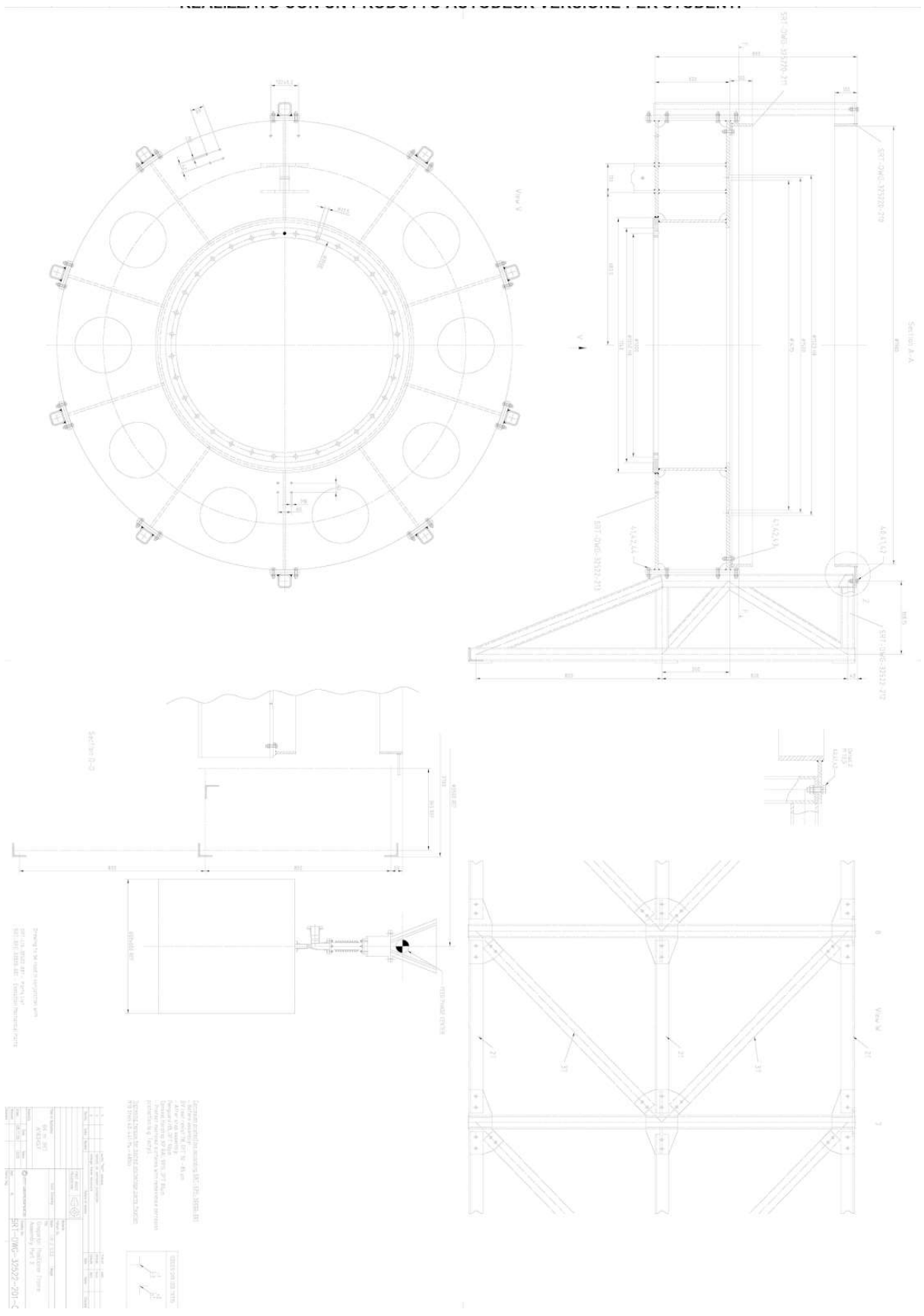

Allegato 7: SRT-LIS-32522-001-05

mt AEROSPACE		Doc. No.: SRT-LIS-32522-001-05					Title PARTS LIST	
WP- / ASSEMBLY Title			DRAWING NO.			WP -No.		
Gergorian Positioner Frame			SRT-DWG-32522-200			32522		
Date of first issue / name		01.03.06 / Doth			Date of last issue / Name		20.08.07 / Doth	
DESCRIPTION	QUANTITY	DIMENSIONS CROSS SECTION x LENGTH (mm)	STANDARD DWG NO	Item	MATERIAL	Weight for 1 part(kg)	Weight-Total(kg)	REMARKS
Sq. Tupe	9	60x60x6x845,7	SRT-DWG-32522-301	1	S355K2G3 (1.0595)	7,950	72	
L-Profile	9	L60x5x559,3	SRT-DWG-32522-302	2	S355K2G3 (1.0595)	2,320	21	
Sq. Tupe	1	60x60x6x872		3	S355K2G3 (1.0595)	8,230	8	
Sq. Tupe	9	60x60x6x268,15	SRT-DWG-32522-304	4	S355K2G3 (1.0595)	2,533	23	
L-Profile	9	L60x5x378,6	SRT-DWG-32522-305	5	S355K2G3 (1.0595)	1,618	15	
Sq. Tupe	9	60x60x6x1700		6	S355K2G3 (1.0595)	16,058	145	
Sq. Tupe	9	60x60x6x873	SRT-DWG-32522-307	7	S355K2G3 (1.0595)	7,579	68	
Plate	1	15x Dia 2010	SRT-DWG-32522-308	8	S235J2G3	206,360	206	
Plate	1	15x Dia 2010	SRT-DWG-32522-309	9	S235J2G3	271,670	272	
Plate	1	25x Dia1140	SRT-DWG-32522-310	10	S235J2G3	56,780	57	
Plate	10	10x300x445	SRT-DWG-32522-311	11	S235J2G3	10,362	104	
Sq. Tupe	9	60x60x6x268,15	SRT-DWG-32522-312	12	S355K2G3 (1.0595)	2,500	23	
Plate	1	10x298x3487,2	SRT-DWG-32522-313	13	S235J2G3	81,580	82	
Plate	20	10x130x415		14	S235J2G3	4,235	85	
Plate	1	10x105x6187		15	S235J2G3	51,000	51	
Plate	4	10x100x300		16	S235J2G3	1,570	6	
Plate	6	8x152x313,6	SRT-DWG-32522-317	17	S235J2G3	1,971	12	
Plate	1	8x100x174,6	SRT-DWG-32522-318	18	S235J2G3	0,946	1	
Plate	1	8x Dia2170		19	S235J2G3	38,890	39	
Plate	6	8x152x313,6	SRT-DWG-32522-317	20	S235J2G3	1,971	12	
L-Profile	24	L60x6x857,8	SRT-DWG-32522-321	21	S355K2G3 (1.0595)	4,645	111	
Plate	2	8x152x174,6	SRT-DWG-32522-322	22	S235J2G3	1,241	2	
Plate	2	8x152x174,6	SRT-DWG-32522-322	23	S235J2G3	1,241	2	
Plate	10	8x60x130		24	S235J2G3	0,490	5	
Plate	19	5x54x54	SRT-DWG-32522-325	25	S235J2G3	0,110	2	
Plate	1	10x92x99,82		26	S235J2G3	0,721	1	

MT REOSPACE		Doc. No.: SRT-LIS-32522-001-05					Title PARTS LIST	
WP- / ASSEMBLY Title			DRAWING NO.			WP -No.		
Gergorian Positioner Frame			SRT-DWG-32522-200			32522		
Date of first issue / name		01.03.06 / Doth		Date of last issue / Name		20.08.07 / Doth		
DESCRIPTION	QUANTITY	DIMENSIONS CROSS SECTION x LENGTH (mm)	STAN- DARD DWG NO	Item	MATERIAL	Weight for 1 part(kg)	Weight- Total(kg)	REMARKS
Plate	1	40x105x110	SRT-DWG-32522-327	27	S235J2G3	3,356	3	
Plate	1	10x84,94x92		28	S235J2G3	0,613	1	
Plate	1	10x90x6187		29	S235J2G3	43,722	44	
Plate	1	10x Dia 1990		30	S235J2G3	26,250	26	
Plate	8	8x100x120	SRT-DWG-32522-331	31	S235J2G3	0,480	4	
L-Profile	8	L60x5x600	SRT-DWG-32522-332	32	S355K2G3 (1.0595)	2,742	22	
Plate	8	8x60x85	SRT-DWG-32522-333	33	S235J2G3	0,330	3	
Plate	2	8x100x315,4	SRT-DWG-32522-334	34	S235J2G3	1,679	3	
Plate	1	8x100x174,6	SRT-DWG-32522-318	35	S235J2G3	0,946	1	
Plate	1	8x244,1x313,6	SRT-DWG-32522-336	36	S235J2G3	3,320	3	
L-Profile	16	L60x5x1024,5	SRT-DWG-32522-337	37	S355K2G3 (1.0595)	4,682	75	
Plate	6	8x244,1x313,6	SRT-DWG-32522-338	38	S235J2G3	2,760	17	
				39				
Hexagon Bolt	212	M10x35	ISO 4017	40	8.8 zinc plated			0
Washer	624	10	ISO 7094	41	200HV zinc plated			0
Hexagon nut	312	M10	ISO 4032	42	8 zinc plated	0,003		1
Hexagon Bolt	20	M10x45	ISO 4017	43	8.8 zinc plated			0
Hexagon Bolt	80	M10x40	ISO 4017	44	8.8 zinc plated			
Total	1							1625
Total	1							1625

The items listed as follows will be supplied by MT at FMC shop:

		Doc. No.: SRT-LIS-32522-001-05				Title PARTS LIST		
WP- / ASSEMBLY Title Gergorian Positioner Frame			DRAWING NO. SRT-DWG-32522-200			WP -No. 32522		
Date of first issue / name		01.03.06 / Doth		Date of last issue / Name		20.08.07 / Doth		
DESCRIPTION	QUANTITY	DIMENSIONS CROSS SECTION x LENGTH (mm)	STANDARD DWG NO	Item	MATERIAL	Weight for 1 part(kg)	Weight-Total(kg)	REMARKS
DESCRIPTION	QUANTITY	DIMENSIONS CROSS SECTION x LENGTH (mm)	STANDARD DWG NO	Item	MT Order Number			
The items listed as follows will be supplied by MT at site:								
DESCRIPTION	QUANTITY	DIMENSIONS CROSS SECTION x LENGTH (mm)	STANDARD DWG NO	Item	MT Order Number			

DOCUMENT CHANGE RECORD

Issue No. / Issue Date	Items changed,	Description of Change	Name
2	1,7,12,17,18,20, 22,23,31 34,35,36,37,38,44 40,41,42	change dimension and quantity new items change quantity	Doth
3	11, 32	quantity changed	Koch
4	11	change dimension, new drawing	Doth
5	34	quantity changed	Doth

	Name	Date	Sign
Approved by			
Released by	Dreyer	03.12.09	

SRT



Doc. No.: SRT-SPE-32525-002-01	Issue No.: 01
Title: Techn. Specification for Gregorian Pos. Bearing	Issue Date: 08.04.04
	Page: 1 of 10

	Name	Date	Sign
Prepared by	H. Merz	09.07.12	<i>H. Merz</i>
Approved by	Dr. H. Kärcher		
Released by	H. Dreger <i>Dr. O. Dreger</i>	09.07.12	<i>H. Dreger</i>

Distribution		
Company	Name	No. of copies
		1

SRT



Doc. No.:	SRT-SPE-32525-002-01	Issue No.:	01
		Issue Date:	08.04.04
Title:	Techn. Specification for Gregorian Pos. Bearing	Page:	2 of 10

DOCUMENT CHANGE RECORD

Issue No.	Issue date	No. Of pages	Pages changed, added, deleted	Description of Change
01	08.04.04	10		Issue 01

Doc. No.:	SRT-SPE-32525-002-01	Issue No.:	01
		Issue Date:	08.04.04
Title:	Techn. Specification for Gregorian Pos. Bearing	Page:	3 of 10

Table of Contents

1	Scope	4
2	Description	4
3	Environmental Conditions	4
4	Kinematic Requirements	5
5	Load Requirements	5
6	Interface and Teeth Requirements	5
7	Compliance Requirements	6
8	Lubrication	6
9	Quality Assurance and Documentation	7
10	Tests	7
11	Protection against Corrosion	8
12	Packing and transport	8
	Figure 1: Gregorian Positioner Assembly	9
	Figure 2: Bearing Interface Requirements	10

Doc. No.:	SRT-SPE-32525-002-01	Issue No.:	01
		Issue Date:	08.04.04
Title:	Techn. Specification for Gregorian Pos. Bearing	Page:	4 of 10

1 Scope

The present specification describes the requirements to be met by the bearing of the Gregorian Positioner assembly.

The Gregorian Positioner bearing is part of the 64m Radio Telescope Sardinia to be built at 600 m altitude.

2 Description

The bearing is a ball bearing type with an internal gear, operating in any positions with axial loads, radial loads and overturning moments.

The inner and the outer rings of the bearing are supported by strong flanges that are welded to the stationary tower and to the rotating frame of the Positioner, see figure 1.

The bearing is lubricated with grease and supplied with seals, grease fittings and lifting eye-bolts for installation and maintenance purpose.

The Gregorian Positioner is driven by two identical pinions. Backlash of the toothing and the pinions itself will be eliminated by the servo system which produces a torque and a counter torque.

3 Environmental Conditions

Site:	Italy – Island of Sardinia appr. 50 km from the city of Cagliari
Ambient temperature	
maximum	+ 50 °C (operation)
minimum	- 15 °C (operation) - 30 °C (survival, no motion, stow position)
Relative atmospheric humidity	100 % with condensation
Atmosphere:	Dusty

Doc. No.:	SRT-SPE-32525-002-01	Issue No.:	01
		Issue Date:	08.04.04
Title:	Techn. Specification for Gregorian Pos. Bearing	Page:	5 of 10

4 Kinematic Requirements

Maximum velocity:	3,5 °/second (0,58 rpm)
Duty cycle:	360 degree rotation, at 3,5 degree/second four times an hour
Lifetime:	20 years

5 Load Requirements

The bearing is designed to meet the following load requirements:

Mode	Radial Load	Axial Load	Moment	Torque	Time	Remark
Unit	N	N	Nm	Nm	%	(-)
Slewing	50.000	50.000	25.000	15.000	100	

6 Interface and Teeth Requirements

The bearing is designed to meet the requirements in figure 2.

Doc. No.:	SRT-SPE-32525-002-01	Issue No.:	01
		Issue Date:	08.04.04
Title:	Techn. Specification for Gregorian Pos. Bearing	Page:	6 of 10

Parameter	Unit	Data	
		Bearing	Pinion
Quantity	--	1	2
Module	m	6	
Number of teeth	z	158	19
Pitch circle diameter	d_o	948	114
Pressure angle	α	20	
Basic rack design	--	DIN 867	
Quality ISO	--	9	8
Addendum modification	x_{m_2}	0.000	3.000
Addendum reduction	k_{m_2}	0.000	0.000
Tip Relief	mm	none	none
Intentional backlash	--	none	none
Outside diameter.	d_k	TBD	TBD
Root circle diameter	d_f	105.000	963.000
Face Width	b	60	60
Load modification	mm	0	0
Theor. Centre distance	a	413,911	
Material	--	46Cr4V	20MnCrS5
Yield limit	σ_s	530	TBD
Tooth surface hardness		280 HB	55-62 RC
Internal backlash	--	none	none
Drawing Number	--	SRT-DWG-32525-301	SRT-DWG-32525-303

7 Compliance Requirements

Repeatable wobble	10 arc-second
Non-repeatable wobble	5 arc second
Radial stiffness	standard, TBD
Axial stiffness	standard, TBD
Friction torque	standard, TBD

8 Lubrication

Lubricant TBD

W:\AuT_Auftrag\SRT\VOL_5_Konfigurierte_Dokumente\10_SPE\SPE_32525_002_01.doc
Technologie

Proprietary of MAN

Doc. No.:	SRT-SPE-32525-002-01	Issue No.:	01
		Issue Date:	08.04.04
Title:	Techn. Specification for Gregorian Pos. Bearing	Page:	7 of 10

9 Quality Assurance and Documentation

The supplier shall have certification according to ISO 9001.

All documentation has to be prepared in English language and shall at least contain.

- Detailed design calculations
- Evidence of quality conformity of the materials in use, according to EN 10204-3.1B
- Dimension data sheets concerning works manufacture
- In-plant test report

The following documentation shall be submitted to the customer on the appropriate dates:

- Tooth geometry data for the pinion
Date: 2 weeks after award of contract
- Mechanical analysis summary showing life and survival margin, axial and radial stiffness and friction torque
Date: 1 month after award of contract
- Bearing drawing showing all main and interface dimensions
Date: 1 month after award of contract
- Operation and maintenance instructions, installation instructions
Date: 1 month before delivery of the bearing
- Material certificates and dimension data sheets concerning works manufacture
Date: at in-plant test
- In-plant test record
Date: 2 weeks after in-plant test

10 Tests

Vendor shall prepare for delivery, FOB shop, acceptance test procedure including test description and measurement data sheets to verify compliance with the technical requirements of this specification.

Test and acceptance will be performed at Vendor shop with MAN and customer representative.

Measured values / inspection results:

- Measurement of interface dimensions
- Measurement of runout
- Friction torque
- Hardness test measurement of tooth surface

Doc. No.:	SRT-SPE-32525-002-01	Issue No.:	01
		Issue Date:	08.04.04
Title:	Techn. Specification for Gregorian Pos. Bearing	Page:	8 of 10

11 Protection against Corrosion

The centering, the contact surfaces and the teeth: treated with a temporary coat easily to remove, e.g. Tectyl

The rest of the outer surfaces: painted (*)

(*) Application of one coat 50 μm of PERMATEX 73082 PVB-EP-Primer

12 Packing and transport

The bearing shall be properly packed suitable for the transport at shop (in Egypt) in order to prevent transport damages (unloading from truck, etc.)

Doc. No.:	SRT-SPE-32525-002-01	Issue No.:	01
Title:	Techn. Specification for Gregorian Pos. Bearing	Issue Date:	08.04.04
		Page:	9 of 10

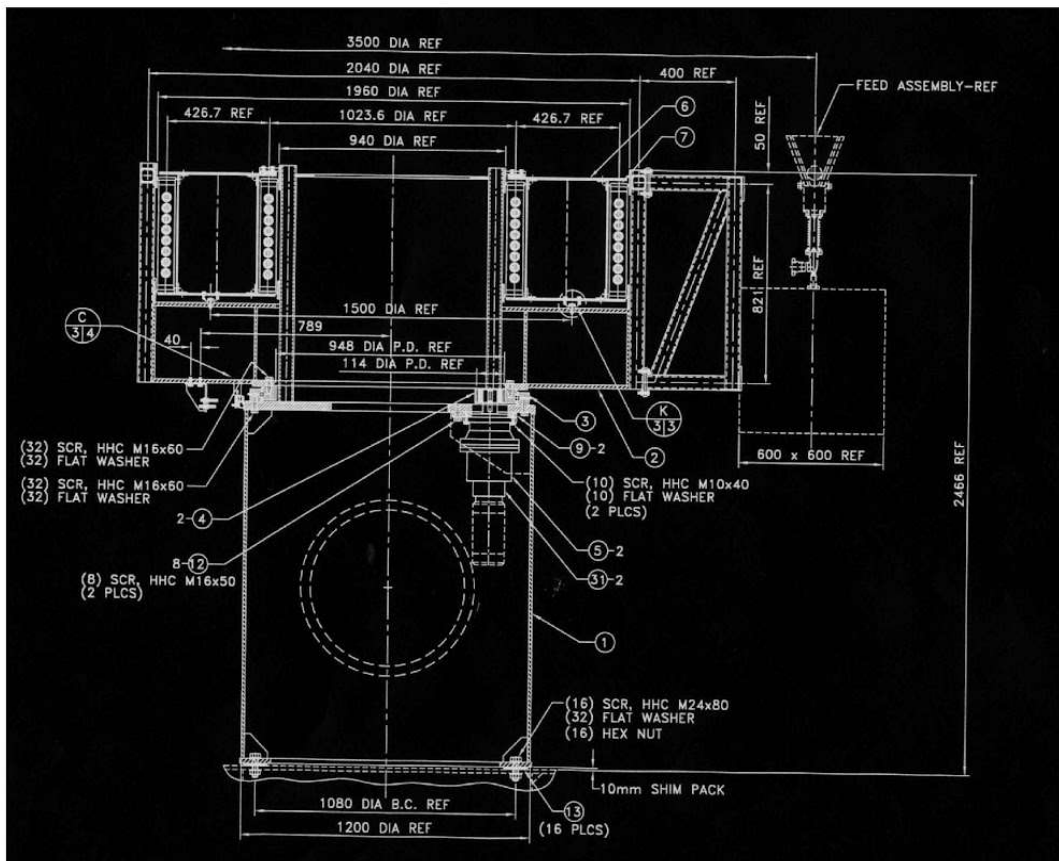

Figure 1 – Gregorian Positioner Assembly

Doc. No.:	SRT-SPE-32525-002-01	Issue No.:	01
		Issue Date:	08.04.04
Title:	Techn. Specification for Gregorian Pos. Bearing	Page:	10 of 10

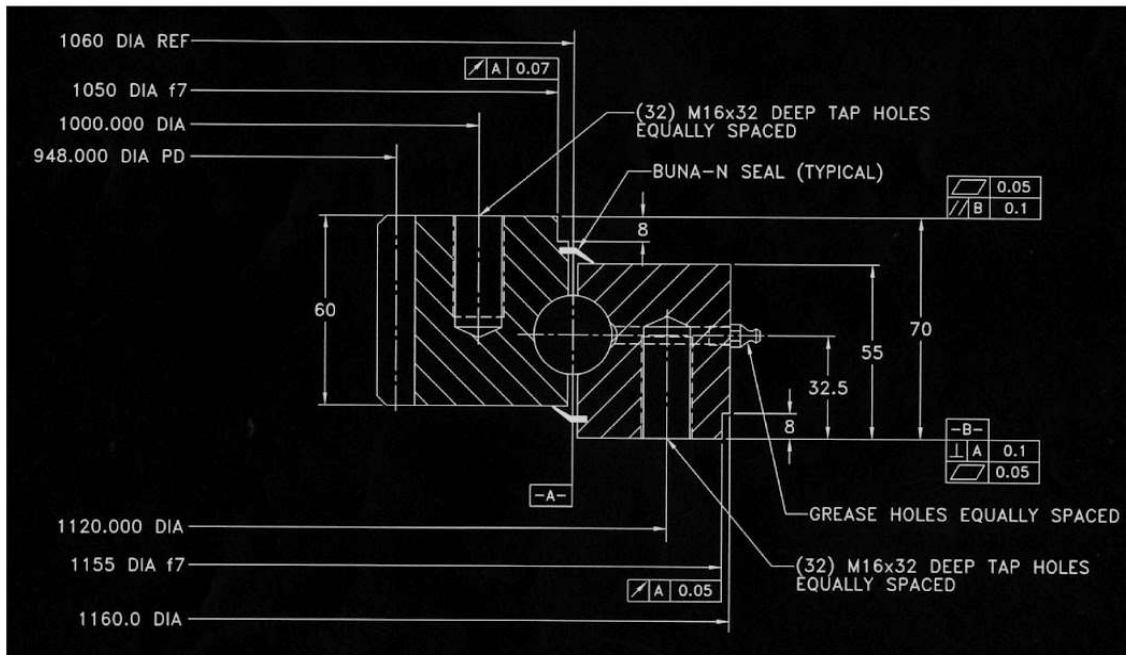

Figure 2 – Bearing Interface Requirements

SRT



Doc. No.:	SRT-ANA-32525-003-01	Issue No.:	01
Title:	Gregorian Positioner Bearing Analysis	Issue Date:	02.06.04
		Page:	1 of 7

	Name	Date	Sign
Prepared by	Bernd Voß (Bearing Supplier Rothe Erde)	02.06.2004	
Approved by	Ulrich Krug (Bearing Supplier Rothe Erde)	02.06.2004	
Released by	Hartmut Dreger <i>Dr. H. Dreger</i>	09.07.12	<i>[Signature]</i>

Distribution		
Company	Name	No. of copies

DOCUMENT CHANGE RECORD				
Issue No.	Issue date	No. Of pages	Pages changed, added, deleted	Description of Change
01	02.06.04	7		Issue 01

W:\AuT_Auftrag\SRT\VOL_5_Konfigurierte_Dokumente\03_ANA\ANA_32525_003_01.doc
 Proprietary of MAN Technologie

Doc. No.: SRT-ANA-32525-003-01	Issue No.: 01
Title: Gregorian Positioner Bearing Analysis	Issue Date: 02.06.04
	Page: 2 of 7

ROTHE ERDE DRWG.-NR.: 062.22.1060.000.41.1123
 ROTHE ERDE ORDER NO.: 63.2.30264

G E A R C A L C U L A T I O N
 PROGRAM STATUS 03.02.2000 GEOMETRY WITH NOMINAL VALUES
 =====
 WHEEL-2 : I N T E R N A L G E A R

HELIX ANGLE AT REFERENCE DIAMETER.....BETA : .000 DEG
 NORMAL PRESSURE ANGLE.....ALFA-0 : 20.000 DEG
 NORMAL MODULE.....MN : 6.000 MM
 TRANSVERSE MODULE.....MT : 6.000 MM
 WORKING TRANSVERSE PRESSURE ANGLE.....ALFA-WT : 18.790 DEG
 WORKING NORMAL PRESSURE ANGLE.....ALFA-WN : 18.790 DEG
 CALCULATED ADD. REDUCTION FROM X1+X2.....*MN : .089 MM

GEAR RATIO Z2/Z1.....U : -8.316
 TRANSVERSE CONTACT RATIO.....EPS-A : 1.595
 OVERLAP RATIO.....EPS-B : .000
 TOTAL CONTACT RATIO (EPS-A) + (EPS-B).....EPS : 1.595
 OPERATING CENTER DISTANCE.....A : -413.911 MM

	WHEEL-1	WHEEL-2
PROVIDED CUTTING TOOL.....	HOB /	
	: RACK CUTTER	PINION CUT.
TOOL ADDENDUM COEFFICIENT.....HAO/MN:	1.250	1.250
TOOL TOOTH TIP RADIUS COEFFICIENT...R/MN:	.250	.000
NO. OF TEETH (PINION CUTTER).....Z0:	.000	25.000
ADDENDUM MODIFIC.COEFF. (PINION CUT.) X0:	.000	.000
FACTOR FOR REMAIN. PROTUBERANCE...PRO/MN:	.000	.000
FACEWIDTH.....B:	63.000	59.000 MM
NO. OF TEETH.....Z:	19.000	-158.000
ADDENDUM MODIFICATION.....XM:	3.000	.000 MM
CONSIDERED ADDENDUM REDUCTION.....KM:	.000	.000 MM
REFERENCE DIAMETER.....D:	114.000	-948.000 MM
WORKING PITCH DIAMETER.....DW:	113.156	-940.978 MM
TIP DIAMETER.....DA:	132.000	-936.000 MM
TIP DIAMETER UTILIZABLE.....DNA:	132.000	-936.000 MM
BASE DIAMETER.....DB:	107.125	-890.829 MM
ROOT DIAMETER UTILIZABLE.....DNF:	109.091	-954.857 MM
FORM DIA. OF DEPENDUM.....DFF:	108.702	-960.336 MM
ROOT DIAMETER.....DF:	105.000	-963.000 MM
NORMAL TOOTH THICKNESS AT TIP.....SAN:	2.742	5.209 MM

W:\AuT_Auftrag\SRT\VOL_5_Konfigurierte_Dokumente\03_ANA\ANA_32525_003_01.doc
 Proprietary of MAN Technologie

Doc. No.:	SRT-ANA-32525-003-01	Issue No.:	01
Title:	Gregorian Positioner Bearing Analysis	Issue Date:	02.06.04
		Page:	3 of 7

TRANSV. TOOTH THICKNESS AT TIP.....SAT:	2.742	5.209 MM
NORMAL SPACEWIDTH AT ROOT DIA.....EFN:	5.208	3.714 MM
TRANSV. SPACEWIDTH AT ROOT DIA.....EFT:	5.208	3.714 MM
SLIDING FACTORS AT TOOTH TIP.....:	.316	.123
SPECIFIC SLIDING AT TIP.....:	.464	.403
SPECIFIC SLIDING AT ROOT.....:	-.675	-.866

G E A R S T R E S S A N A L Y S I S , B A S E D O N N I E M A N N B O O K N O . 2 / 1 9 6 0

=====

W H E E L - 2 : I N T E R N A L G E A R

GENERAL DATA AND MATERIAL DATA

KEY (O.U.K=1, OTHERWISE=0)	:	0
KEY (MATING ST/ST=0, ST/ALU=1)	:	0
KEY (MATING W. HARDENED PINION=1, OTHERW.=0)	:	1
SEATING COEFF. GK=0 PINION SUPP. EACH SIDE	GK:	.30
GK=0.3 PINION OVERHUNG		
CONSIDERED FACE WIDTH AT BENDING (MM)	:	59.00
CONSIDERED FACE WIDTH AT PITTING (MM)	:	59.00

	WHEEL-1	WHEEL-2
GEAR QUALITY AS PER DIN	: 8	9
KEY, CROSS SECTION OF RING (1,2,3)	: 1	1
	: 20MNCR5E	42CRMO4V
HARDENING METHOD	: CASE HARDENED	
FLANK STRENGTH (N/MM2)	K0: 49.00	10.60
ROOT STRENGTH (N/MM2)	SIGMA-0: 461.00	310.00
STATIC STRENGTH (N/MM2)	SIGMA-OB: 1570.00	1080.00
AVAILABLE FLANK HARDNESS	HBV: 650.00	280.00
COMPARISON HARDNESS FOR FLANK	HBT: 650.00	280.00
YIELD STRENGTH (N/MM2)	SIGMA-0,2: 635.00	635.00

Doc. No.: SRT-ANA-32525-003-01	Issue No.: 01
Title: Gregorian Positioner Bearing Analysis	Issue Date: 02.06.04
	Page: 4 of 7

LOADS AND SAFETY FACTORS		WHEEL -1	WHEEL-2
NO. OF DRIVING PINIONS	:	1	
DRIVE TORQUE (N*M)	MD:	1803.80	15000.00
ROTATIONAL SPEED (1/MIN)	DREHZ:	4.82	.58
TANGENTIAL FORCE AT PCD OF ENGAGEM. (KN)	FU:	31.88	
SHOCK COEFFICIENT	CS:	1.00	
LUBRICATION COEFFICIENT	YS:	1.00	
FACTOR	:	.70	
DIRECTION OF ROTATING CHANGING= 0.7			
UNIDIRECTIONAL ROTATING = 1			
SAFETY AGAINST FATIGUE FRACTURE	SB:	1.86	1.45
FULL LOAD LIFE AT SB<1	LHB:*****	*****	*****
SAFETY AGAINST PITTINGS	SG:	2.02	.48
FULL LOAD LIFE AT SG<1	LHG:*****	49641.96	
SAFETY AGAINST FORCED RUPTURE	SBR:	8.84	5.35
HERTZIAN-PRESS. AT PITCH POINT (N/MM2)	PHC:	1058.034	
STRIBECK-PRESS. AT PITCH POINT (N/MM2)	KC:	15.542	

RACEWAY CALCULATION

GENERAL RACEWAY DATA

RACEWAY-Ø (MM)	:1060
BALL-DIAMETER (MM)	:22
NOMINELL NO. OF BALLS	:122

LOAD CASE

FA= AXIAL LOAD	= 50 KN
FR= RADIAL LOAD	= 50 KN
MK= TILTING MOMENT	= 25 KNM

PEAK LOAD ON MAX. LOADED BALL = 2,53 KN

STATIC SAFETY CALCULATION

$$S_{st} = \frac{Q_{03}}{Q_{ges}} = \frac{16,11KN}{2,53KN} = 6,37 \text{ fold}$$

Doc. No.: SRT-ANA-32525-003-01

Issue No.: 01

Issue Date: 02.06.04

Title: Gregorian Positioner Bearing Analysis

Page: 5 of 7

B O L T C A L C U L A T I O N

RACEWAY DIA OF UPLIFTING RACEWAY DL : 1060.00 MM
 FACTOR FOR CALCULATION OF FK-ERF-REIB SMALL K : 4.37

DESCRIPTION	I DIMEN- I SION	I SYMBOL	I	I OUTER	I INNER
BOLT CIRCLE DIA	I MM	I LA/LI	I	1120.00I	1000.00
TIGHTENING FACTOR (FMMAX/FMMIN)	I	I ALPHA-A	I	1.60I	1.60
NO. OF BOLTS	I	I SMALL N	I	32.00I	32.00
BOLT DIA	I MM	I SMALL D	I	16.00I	16.00
NOMINAL CROSS SECTION	I MM2	I AN	I	201.06I	201.06
STRESS CROSS SECTION	I MM2	I AS	I	156.67I	156.67
CROSS SECTION AT MINOR DIA	I MM2	I AD3	I	144.12I	144.12
BOLT STRENGTH GRADE ISO 898 0,2-PROOF STRESS	I N/MM2	I RP0,2	I	10.90I	10.90
FORCE AT 0,2-PROOF STRESS	I N	I F0,2	I	147266.I	147266.
NOMINAL PRELOAD (% RP0,2)	I %	I	I	IABT. 70.00I	IABT. 70.00
DEGREE OF EXPLOITATION OF	I	I NUE	I	.90I	.90
YIELD LOAD DURING TIGHTENG.	I	I	I	I	I
FRICITION COEFF. IN THREAD	I	I MUE-G	I	.140I	.140
INITIAL CLAMPING FORCE OF THE SELECTED BOLT	I N	I FM	I	106582.I	106582.
STRESS AMPLITUDE FOR ENDURANCE LIMIT	I N/MM2	I SIGMA-A	I	47.44I	47.44
DIA OF AREA UNDER BOLT HEAD OR NUT (1.5*D)	I MM	I SMALL DW	I	24.00I	24.00
HOLE DIA (1.155*D)	I MM	I SMALL DH	I	18.48I	18.48
DIA FOR CALCULATION OF AERS (DA = 1.6*DW)	I MM	I DA	I	38.40I	38.40
CLAMPING LENGTH I STEEL	I MM	I SMALL LK1	I	80.00I	80.00
SHARE OF PARTS I KUNSTST.	I MM	I SMALL LK2	I	.00I	.00
BOLTED TOGETHER I ALUMIN.	I MM	I SMALL LK3	I	.00I	.00
ASSOCIATED YOUNG'S MODULUS OF PARTS BOLTED TOGETHER	I N/MM2	I EP1	I	205000.00I	205000.00
	I N/MM2	I EP2	I	.00I	.00
	I N/MM2	I EP3	I	.00I	.00

W:\AuT_Auftrag\SRTVOL_5_Konfigurierte_Dokumente\03_ANA\ANA_32525_003_01.doc
 Proprietary of MAN Technologie

SRT



Doc. No.:	SRT-ANA-32525-003-01	Issue No.:	01
Title:	Gregorian Positioner Bearing Analysis	Issue Date:	02.06.04
		Page:	6 of 7

YOUNG'S MODULUS OF BOLT MATERIAL	I	N/MM2	I	ES	I	205000.00I	205000.00
	I		I		I		I
	I		I		I		I
FRICITION COEFFICIENT BETW. CONTACT SURFACES	I		I	MUE	I	.15I	.15
	I		I		I		I
	I		I		I		I
RING SEGMENTED (0=NO/1=YES)	I		I		I	.00I	.00

LOAD CASE

 FA= AXIAL LOAD = 50 KN
 FR= RADIAL LOAD = 50 KN
 MK= TILTING MOMENT = 25 KNM

DESCRIPTION	I	DIMEN- SION	I	SYMBOL	I	OUTER	I	INNER
AXIAL WORKING FORCE OF BOLTS (CALCULATED ITERATIVELY FROM THE RACEWAY LOADS)	I	N	I	FA	I	3973.69I		3973.69
	I		I		I			I
	I		I		I			I
SUBSTITUTIONAL AREA	I	MM2	I	A-ERS	I	642.40I		642.40
	I		I		I			I
	I		I		I			I
ELASTIC RESILIENCE OF BOLTED PARTS	I	IMUE*M/NI	I	DELTA-P	I	.0006075I		.0006075
	I		I		I			I
	I		I		I			I
ELASTIC RESILIENCE OF BOLT	I	IMUE*M/NI	I	DELTA-S	I	.0025222I		.0025222
	I		I		I			I
	I		I		I			I
LOAD RATIO	I		I	PHI-K	I	.1941I		.1941
	I		I		I			I
	I		I		I			I
EMBEDDING	I	MUE*M	I	SMALL FZ	I	5.69I		5.69
	I		I		I			I
	I		I		I			I
LOSS OF PRELOAD DUE TO EMBEDDING	I	N	I	FZ	I	1816.94I		1816.94
	I		I		I			I
	I		I		I			I
REQUIRED CLAMPING FORCE (TERM: SMALL FE*FA)	I	N	I	FK-ERF	I	952.I		952.
	I		I		I			I
	I		I		I			I
FACTOR (RELATIVE TO BRG.-TYPE AND LOAD COMBINATION)	I		I	SMALL FE	I	.2396I		.2396
	I		I		I			I
	I		I		I			I
CALCULATED CLAMPING FORCE FOR BOLT SELECTION	I	N	I	FMMAX	I	9986.I		9986.
	I		I		I			I

W:\AuT_Auftrag\SRTVOL_5_Konfigurierte_Dokumente\03_ANA\ANA_32525_003_01.doc
 Proprietary of MAN Technologie

SRT



Doc. No.:	SRT-ANA-32525-003-01	Issue No.:	01
		Issue Date:	02.06.04
Title:	Gregorian Positioner Bearing Analysis	Page:	7 of 7

ALTERNATING STRESS OF BOLT	I	I	I	I	I	I
	I	N/MM2	I	SIGMA--	I	3.48I
	I		I	SMALL A	I	3.48
PART OF WORKING FORCE FA WHICH LOADS THE BOLT ADD.	I	N	I	FSA	I	501.I
	I		I		I	501.
RESIDUAL CLAMPING FORCE	I	N	I	FKR	I	61324.I
	I		I		I	61324.
CLAMPING FORCE REQUIRED FOR FRICTIONAL ENGAGEMENT	I	N	I	FK-ERF	I	45521.I
	I		I	REIB	I	45521.