



<b>Publication Year</b>	2006
<b>Acceptance in OA</b>	2024-03-07T10:12:22Z
<b>Title</b>	FM 44GHz RCA26 Data Analysis Report
<b>Authors</b>	VILLA, Fabrizio, BATTAGLIA, Paola Maria, CUTTAIA, FRANCESCO, TERENCE, LUCA, SANDRI, MAURA, Salmon, M., VALENZIANO, Luca
<b>Handle</b>	<a href="http://hdl.handle.net/20.500.12386/34912">http://hdl.handle.net/20.500.12386/34912</a>
<b>Volume</b>	PL-LFI-PST-RP-018



**TITLE:**

# **FM 44GHz RCA26 Data Analysis Report**

**DOC. TYPE:** REPORT

**PROJECT REF.:** PL-LFI-PST-RP-018

**PAGE:** I of III, 40

**ISSUE/REV.:** 1.0

**DATE:** Aug. 2006

<p><b>Prepared by</b></p>	<p><b>F.VILLA, P.BATTAGLIA, F.CUTTAIA, L.TERENZI, M.SANDRI, M.SALMON, L.VALENZIANO LFI Project System Team</b></p>	<p><b>Date:</b> Aug 25<sup>th</sup>, 2006</p> <p><b>Signature:</b></p>
---------------------------	--	--



<b>Agreed by</b>	<b>M. BERSANELLI</b> <b>LFI</b> <b>Instrument Scientist</b>	<b>Date: Aug 25<sup>th</sup>, 2006</b>  <b>Signature:</b>
<b>Agreed by</b>	<b>C. BUTLER</b> <b>LFI</b> <b>Program Manager</b>	<b>Date: Aug 25<sup>th</sup>, 2006</b>  <b>Signature:</b>
<b>Approved by</b>	<b>N. MANDOLESI</b> <b>LFI</b> <b>Principal Investigator</b>	<b>Date: Aug 25<sup>th</sup>, 2006</b>  <b>Signature:</b>







## TABLE OF CONTENTS

<b>TABLE OF CONTENTS</b> .....	<b>3</b>
<b>1 INTRODUCTION AND SCOPE</b> .....	<b>1</b>
<b>2 APPLICABLE DOCUMENTS</b> .....	<b>3</b>
<b>3 REFERENCE DOCUMENTS</b> .....	<b>3</b>
<b>4 TUNING</b> .....	<b>4</b>
4.1 BACK END MODULE OFFSET (OK --- PAOLA) .....	4
<b>5 BASIC PERFORMANCES</b> .....	<b>4</b>
5.1 RCA_OFT: RADIOMETER OFFSET .....	4
5.1.1 <i>Temperature offset</i> .....	4
5.2 RCA_LING: LINEARITY, ISOLATION, NOISE AND GAIN.....	6
5.2.1 <i>FEM performance summary</i> .....	6
5.2.2 <i>Reference temperature steps</i> .....	7
5.2.3 <i>Sky Temperature Steps</i> .....	10
5.2.4 <i>Comparison between RCA data and data extrapolated from measurements on FEM 4F3</i> .....	13
5.2.5 <i>Consistency of the Results based on SKY steps</i> .....	15
5.2.6 <i>Consistency of the Results based on REF steps</i> .....	17
5.3 RCA_SPR: BANDPASS MEASUREMENT.....	18
<b>6 NOISE PROPERTIES</b> .....	<b>18</b>
6.1 RCA_STN.....	18
6.1.1 <i>One-Over-F Noise</i> .....	19
6.1.2 <i>White Noise Level and Equivalent Bandwidth</i> .....	20
6.2 RCA_UNC: UNCHOPPED DATA.....	21
6.2.1 <i>PS/SW ln1 diode reverse, ln2 diode forward on all channels</i> .....	21
6.2.2 <i>PS/SW ln1 diode reverse, ln2 diode forward on Channels M2/S2; ln1 diode forward, ln2 diode reverse on Channels M1/S1</i> .....	23
6.2.3 <i>PS/SW ln1 diode forward, ln2 diode reverse on all channels</i> .....	24
6.2.4 <i>PS/SW ln1 diode reverse, ln2 diode forward on Channels M1/S1; ln1 diode forward, ln2 diode reverse on Channels M2/S2</i> .....	25
<b>7 SUSCEPTIBILIY TESTS</b> .....	<b>26</b>
7.1 RCA_THV: SUSCEPTIBILITY TO V-GROOVE TEMPERATURE VARIATIONS.....	26
7.2 RCA_THB: SUSCEPTIBILITY TO BEM TEMPERATURE VARIATIONS .....	26
7.3 RCA_THF: SUSCEPTIBILITY TO FEM TEMPERATURE VARIATIONS.....	26
7.3.1 <i>Analysis using the SKY_TEMP probe as sky load temperature:</i> .....	28
7.3.2 <i>Analysis using the SMON_TMP probe as sky load temperature:</i> .....	33
7.4 RCA_ELE: SUSCEPTIBILITY TO DISTURBANCE ON BIAS LINES .....	38
<b>8 CONCLUSIONS AND CALIBRATION MATRIX</b> .....	<b>38</b>
<b>9 GAIN MODEL</b> .....	<b>38</b>



## 1 INTRODUCTION AND SCOPE

This document reports on the RCA26 Flight Model on – ground calibration. Tests were performed from 21 April 2006 to 03 May 2006 (including functional tests) at Alcatel Alenia Space – Milano according to the LFI Calibration Plan.

The following tests have been performed:

Date	Filename	Notes
21-apr-06	030LFI26_RCA_FM_AMB_200604211855	RCA functional test at ambient temperature
21-apr-06	044LFI26_RCA_FM_AMB_200604211908	RCA functional test at ambient temperature all channels on
22-apr-06	044LFI26_RCA_FM_AMB_200604221109	RCA SPR check at room temp. on MAIN only, Pol. Plane less than -45deg
22-apr-06	044LFI26_RCA_FM_AMB_200604221145	RCA SPR check at room temp. on SIDE only, Pol. Plane less than -45deg; file USELESS due to RACHEL problems
22-apr-06	044LFI26_RCA_FM_AMB_200604221147	RCA SPR check at room temp. on SIDE only, Pol. Plane less than -45deg
22-apr-06	044LFI26_RCA_FM_AMB_200604221217	RCA SPR check at room temp. on MAIN only, Pol. Plane -45deg; Channel A and B now show good response.
22-apr-06	044LFI26_RCA_FM_AMB_200604221238	RCA SPR check at room temp. on SIDE only, Pol. Plane -45deg;
27-apr-06	044LFI18_RCA_FM_CRY_200604270835	RCA functional test at cryogenic temperature
27-apr-06	044LFI26_RCA_FM_CRY_200604270910	RCA functional test at cryogenic temperature
27-apr-06	044LFI26_RCA_FM_XXX_200604270944	RCA 26 Phase Switch I-V curves 1st check
27-apr-06	044LFI26_RCA_FM_TUN_200604271058	PS/SW tuning
27-apr-06	044LFI26_RCA_FM_TUN_200604271206	VG1 tuning
27-apr-06	044LFI26_RCA_FM_TUN_200604271508	VG2 tuning
27-apr-06	044LFI26_RCA_FM_TUN_200604271822	DAE EBB Tuning
27-apr-06	044LFI26_RCA_FM_ST3_200604271919	RCA ST3 test
28-apr-06	044LFI26_RCA_FM_ST3_200604280358	"
28-apr-06	044LFI26_RCA_FM_THF_200604281128	Test interrupted due to erroneous closure of RACHEL programme. File corrupted
28-apr-06	044LFI26_RCA_FM_THF_200604281235	File corrupted
28-apr-06	044LFI26_RCA_FM_XXX_200604281538	File for testing RACHEL functionality
28-apr-06	044LFI26_RCA_FM_THF_200604281611	RCA THF test. Interrupted to set the correct RACHEL parameters (offset, gain, labels, etc.)
28-apr-06	044LFI26_RCA_FM_THF_200604281615	RCA THF test
28-apr-06	044LFI26_RCA_FM_OFT_200604281722	RCA offset test; search for equal Vout on all Channels
28-apr-06	044LFI26_RCA_FM_SPR_200604281838	RCA SPR test (input power = -32 dBm)
28-apr-06	044LFI26_RCA_FM_XXX_200604281912	Long overnight acquisition in nominal working conditions. File corrupted (during the night a storm caused a power interruption)
29-apr-06	044LFI26_RCA_FM_AMB_200604291042	Check on radiometer functionaity
29-apr-06	044LFI26_RCA_FM_LIS_200604291450	RCA LIS test with steps on sky and reference load
29-apr-06	044LFI26_RCA_FM_LIS_200604292326	"
30-apr-06	044LFI26_RCA_FM_LIS_200604300759	"
30-apr-06	044LFI26_RCA_FM_LIS_200604301632	"
01-mag-06	044LFI26_RCA_FM_LIS_200605010106	"
01-mag-06	044LFI26_RCA_FM_LIS_200605010940	"
01-mag-06	044LFI26_RCA_FM_LIS_200605011813	"
02-mag-06	044LFI26_RCA_FM_LIS_200605020246	"
02-mag-06	044LFI26_RCA_FM_LIS_200605021037	RCA ELE test on VG1 Channel S1
02-mag-06	044LFI26_RCA_FM_LIS_200605021134	RCA ELE test on VG2 Channel S1
02-mag-06	044LFI26_RCA_FM_LIS_200605021210	RCA ELE test on Vdr Channel S1
02-mag-06	044LFI26_RCA_FM_UNC_200605021247	RCA unchoped test (tsky=13k, tref=8.5K); PS/SW In1 diode rev., In2 diode for. On all channels
02-mag-06	044LFI26_RCA_FM_UNC_200605021346	RCA unchoped test (tsky=13k, tref=8.5K); PS/SW In1 diode rev., In2 diode for. On Channels M2/S2; In1 diode for., In2 diode rev. on Channels M1/S1
02-mag-06	044LFI26_RCA_FM_UNC_200605021453	RCA unchoped test (tsky=13k, tref=8.5K); PS/SW In1 diode for., In2 diode rev. on all channels
02-mag-06	044LFI26_RCA_FM_UNC_200605021546	RCA unchoped test (tsky=13k, tref=8.5K); PS/SW In1 diode rev., In2 diode for. on Channels M1/S1; In1



		diode for., In2 diode rev. on Channels M2/S2
02-mag-06	044LFI26_RCA_FM_THV_200605021656	RCA susceptibility test to thermal changes in the VG-3
02-mag-06	044LFI26_RCA_FM_UNC_200605021759	RCA unchopped test 20K-20K (overnight acquisition, 3hrs at 20K-20K)
03-mag-06	044LFI26_RCA_FM_XXX_200605031010	RCA 26 Phase Switch I-V curves 2nd check
03-mag-06	044LFI26_RCA_FM_THB_200605031052	RCA susceptibility to thermal variations in the BEM



## 2 APPLICABLE DOCUMENTS

- [AD 1] M.Bersanelli, *Planck-LFI Calibration Plan*, PL-LFI-PST-PL-008, Issue/Rev 1.0, July 2003
- [AD 2] E.Alippi, P.Guzzi, *Planck LFI 44GHz Radiometer Chain Assembly (RCA) Specification*, Issue/Rev. 2.0, March 2002

## 3 REFERENCE DOCUMENTS

- [RD 1] A.Mennella, et. al, *Data analysis and calibration matrix of LFI 44 GHz QM receiver (LFI24)*, PL-LFI-PST-AN-003, Issue/Rev 1.0, May 2005
- [RD 2] P. Battaglia, *44GHz RCA #26 FM Test Report*, PL-LFI-LAB-RP-059, Issue 1
- [RD 3] F. Cuttaia, A. D'Arcangelo, D. Lawson, L. Stringhetti, *nonlinearity investigation at 44 GHz using prototype units: BEM44\_B3\_DC and BEM44\_B4\_DC*, PL-LFI-PST-TN-073, 1.0



## 4 TUNING

See [RD 2]

### 4.1 BACK END MODULE OFFSET (OK --- PAOLA)

BEM offset is determined by recording each detector output when the FEM is off. The values stored are used in data analysis when required. The values are reported in *Table 5-1*.

*Table 5-1: BEM offset values.*

	BEM offset (Volts)
Detector A	0.0048
Detector B	0.0045
Detector C	0.0048
Detector D	0.0056

## 5 BASIC PERFORMANCES

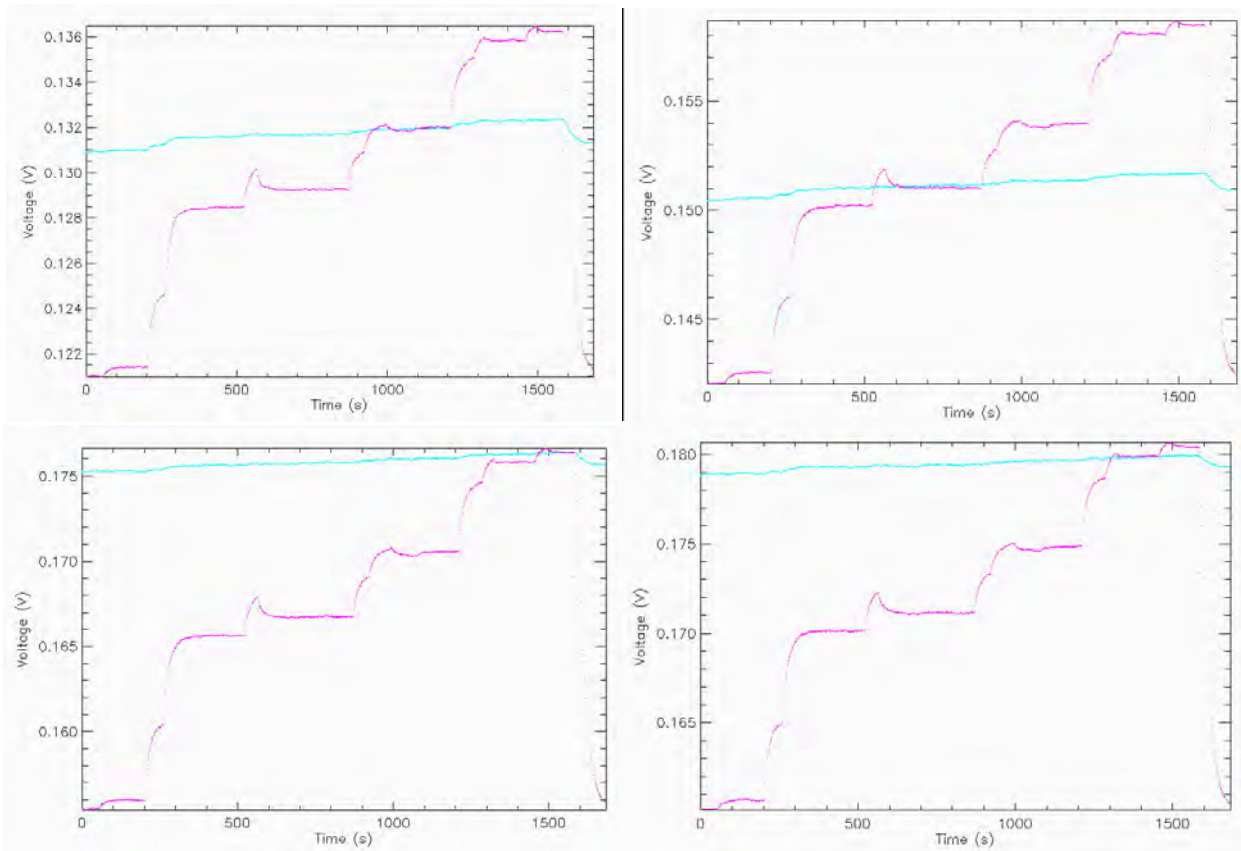
### 5.1 RCA\_OFT: RADIOMETER OFFSET

#### 5.1.1 Temperature offset

Temperature offset is measured as follows:

- DAE gain and offset are set to 1 and 0, respectively
- Sky Load control temperature is kept constant (the actual temperature changes due to the thermal interconnection between the Sky Load and the Reference Load)
- Reference temperature is changed until the Voltage output between sky and load signals is as close as possible.
- This process is repeated for all channels.

The output of the 044LFI26\_RCA\_FM\_OFT\_200604281722 dataset is reported in **Figure 6-1**.



**Figure 6-1:** Voltage output. Upper panel: left, channel A, right, channel B. Lower panel: left, channel C, right, channel D. Changing signal is the reference output.

Data are selected in `Rana_view` where the output is equal within the standard deviation. Temperature data are measured in the same time interval (see Figure 6-2).

Temperature sensors for  $T_{sky}$  and  $T_{ref}$  are mounted on the copper flanges which provide the control stages for the two loads, respectively. SMON sensor is mounted on one of the ECCOSORB pyramids inside the Sky Load. RMON sensor is stucked on the Al case od the Reference Load.

The temperature offset is calculated, in antenna temperature, as  $T_{sky}-T_{ref}$  and  $SMON-RMON$ . Sigma is calculated as  $\sigma = \sqrt{\sigma_{T_{sky}}^2 + \sigma_{T_{ref}}^2}$ . Results are reported in Table 6-1.



**Table 6-1** Voltage offset values are reported in columns  $T_{sky}-T_{ref}$  (Temperature measured at the interface with the control stage) and  $SMON-RMON$  (temperature measured at the tip of a pyramid inside the Sky Load and on the Reference Load Aluminium case, respectively).

Ch	Tsky	Tref	V <sub>sky</sub>	$\sigma_{V_{sky}}$	V <sub>ref</sub>	$\sigma_{V_{ref}}$	$T_{sky}-T_{ref}$	$\sigma$	SMON-RMON	$\sigma$	V <sub>sky</sub> -V <sub>ref</sub>	$\sigma(S-R)$
A	13.078	10.9500	0.1320	0.0003	0.1320	0.0004	2.125	0.002	2.280	0.002	0.0000	0.0005
B	13.032	10.2000	0.1511	0.0003	0.1510	0.0003	2.828	0.001	3.000	0.002	0.0001	0.0004
C	13.1471	12.1000	0.1764	0.0004	0.1764	0.0004	1.046	0.001	1.154	0.002	0.0000	0.0006
D	13.131	12.0000	0.1798	0.0004	0.1799	0.0004	1.130	0.003	1.241	0.003	-0.0001	0.0006

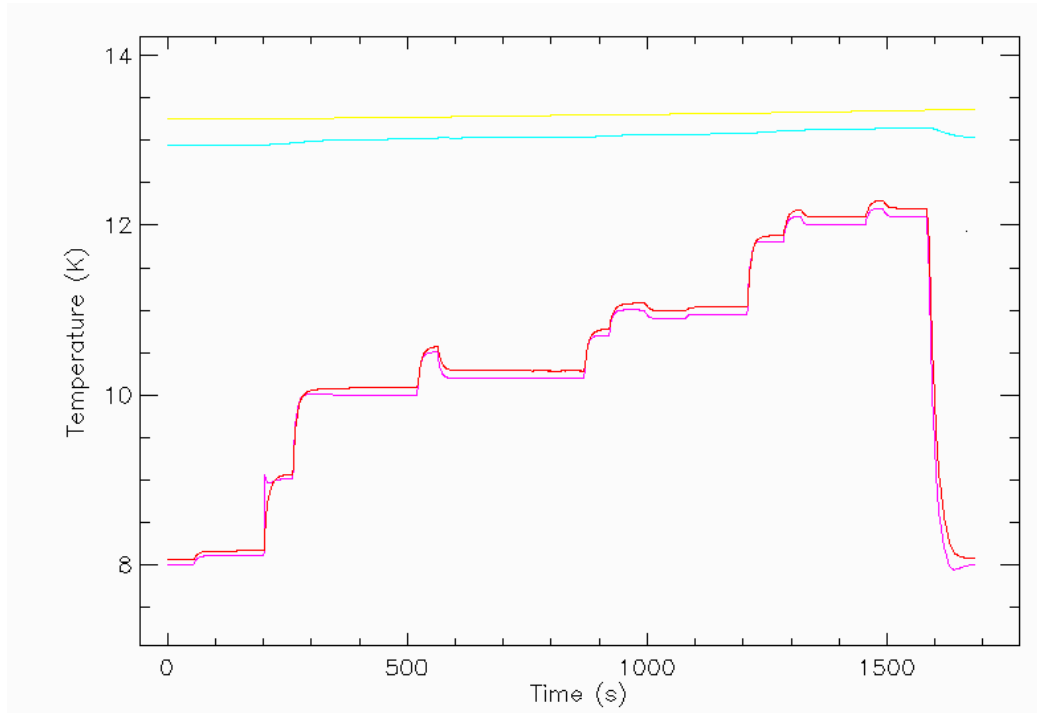


Figure 6-2: Temperature sensor output: yellow: SMON (sky Load Eccosorb pyramid tip); light blue: Tsky (Sky load control temperature); violet: RMON (Reference Load case); red Tref (Reference Load control).

## 5.2 RCA\_LING: LINEARITY, ISOLATION, NOISE AND GAIN

This test includes both the RCA\_LIS and the RCA\_TNG. Files are named LIS. The linearity has been evaluated extensively by changing both the REF and the SKY temperature in several steps. From this data the noise temperature, isolation and gain can be also evaluated.

### 5.2.1 FEM performance summary

Here we report briefly the performances of the Front End Module 4F3 to be used as a reference for the performances measured on the RCA26. Numbers are derived from [RD 4]. The noise temperatures



**Table 6-2:** Noise Temperatures, gains, and Bandwidth derived from FEM after gold re-plating. LNA are listed following JBO naming convention. For Tnoise numbers in between parenthesis are corrected for isolation and measured using REF load steps. Noise temperature are calculated using **Physical Temperature**.

	T Noise FEM (K)	Gain dB	Bandwidth GHz
LNA 1 (OP1)	15.5 (14.7)	30.8	6.9
LNA 4 (OP2)	-	-	-
LNA 2 (OP3)	16.8 (15.1)	32.1	6.8
LNA 3 (OP4)	-	-	-

Specifically the analysis has been performed on the following datasets:

reference load temperature steps:

044LFI26\_RCA\_FM\_LIS\_200604300759  
 044LFI26\_RCA\_FM\_LIS\_200604301632

sky load temperature steps:

044LFI26\_RCA\_FM\_LIS\_200605010106  
 044LFI26\_RCA\_FM\_LIS\_200605020246  
 044LFI26\_RCA\_FM\_LIS\_200605010940  
 044LFI26\_RCA\_FM\_LIS\_200605011813

From these datasets the characteristic curves V output Vs. T input were built for each detector and then linear and parabolic fits have been performed, as reported in next sections.

### 5.2.2 Reference temperature steps

The data were collected from the files 044LFI26\_RCA\_FM\_LIS\_200604300759 and 044LFI26\_RCA\_FM\_LIS\_200604301632

Hereafter the input data used for the analysis are reported:



**Table 6-3:** Input data used to derive the calibration curve of the RCA using temperature steps on REF. All the temperature are Physical (Kelvin). Voltages are in Volts.

Detector A				Detector B			
Tchange REF	Tfixed SKY	Vchange	Vfixed	Tchange REF	Tfixed SKY	Vchange	Vfixed
8.0575094	13.302290	0.12366971	0.13407882	8.0575094	13.302290	0.14559806	0.15435825
9.6763506	13.359097	0.12962312	0.13467341	9.6763506	13.359097	0.15213254	0.15486576
11.903000	13.513477	0.13771096	0.13575673	11.903000	13.513477	0.16097208	0.15586852
14.121634	13.728802	0.14566378	0.13709732	14.121634	13.728802	0.16941352	0.15703295
16.337999	13.977970	0.15337920	0.13849933	16.337999	13.977970	0.17764156	0.15838468
18.558001	14.255000	0.16102002	0.14006398	18.558001	14.255000	0.18573497	0.15988803
20.770071	14.542594	0.16843208	0.14162830	20.770071	14.542594	0.19338134	0.16131446
22.983999	14.842295	0.17575860	0.14327084	22.983999	14.842295	0.20095601	0.16286282
25.194000	15.131333	0.18282317	0.14478077	25.194000	15.131333	0.20825072	0.16432347
27.399000	15.427941	0.18980202	0.14636070	27.399000	15.427941	0.21528711	0.16574268
29.600000	15.709764	0.19672136	0.14793781	29.600000	15.709764	0.22235124	0.16730375
31.820999	15.981098	0.20360143	0.14954036	31.820999	15.981098	0.22926607	0.16880692
34.016998	16.229609	0.21033770	0.15109191	34.016998	16.229609	0.23588753	0.17024092
Detector C				Detector D			
Tchange REF	Tfixed SKY	Vchange	Vfixed	Tchange REF	Tfixed SKY	Vchange	Vfixed
8.0575094	13.302290	0.15910311	0.17919273	8.0575094	13.302290	0.16368928	0.18258663
9.6763506	13.359097	0.16737162	0.17972698	9.6763506	13.359097	0.17183902	0.18313337
11.903000	13.513477	0.17858094	0.18080969	11.903000	13.513477	0.18268061	0.18408401
14.121634	13.728802	0.18942446	0.18213982	14.121634	13.728802	0.19314814	0.18533876
16.337999	13.977970	0.20002405	0.18369068	16.337999	13.977970	0.20324365	0.18675334
18.558001	14.255000	0.21042219	0.18537776	18.558001	14.255000	0.21313924	0.18836793
20.770071	14.542594	0.22035889	0.18698826	20.770071	14.542594	0.22255812	0.18993517
22.983999	14.842295	0.23027451	0.18879941	22.983999	14.842295	0.23177797	0.19159444
25.194000	15.131333	0.23985698	0.19049071	25.194000	15.131333	0.24080998	0.19328149
27.399000	15.427941	0.24937918	0.19232171	27.399000	15.427941	0.24954289	0.19495071
29.600000	15.709764	0.25849525	0.19392446	29.600000	15.709764	0.25790783	0.19647869
31.820999	15.981098	0.26768162	0.19564896	31.820999	15.981098	0.26634881	0.19814979
34.016998	16.229609	0.27680356	0.19743766	34.016998	16.229609	0.27447234	0.19975483

The following fits have been performed (V is voltage in Volt and T is the input antenna temperature in Kelvin):

- linear fit:  $V=a_0+a_1*T$
- parabolic fit V(T):  $V=a_0+a_1*T+a_2*T^2$
- inverse parabolic fit T(V):  $T=a_0+a_1*V+a_2*V^2$

The fit results are reported here:

**Table 6-4:** Fitting parameters for REF steps.

	Linear		Parabolic V(T)			Inverse Parabolic T(V)		
	a0	a1	a0	a1	a2	a0	a1	a2
<b>Detector A</b>	0.10156	0.00334	0.09696	0.0039	-1.40696E-5	-20.13433	173.08466	377.95202
<b>Detector B</b>	0.12333	0.00348	0.11629	0.00433	-2.15272E-5	-17.16131	91.80566	511.81203
<b>Detector C</b>	0.12951	0.00453	0.12220	0.00542	-2.23476E-5	-17.46180	115.76598	240.45995
<b>Detector D</b>	0.13656	0.00426	0.12743	0.00537	-2.78962E-5	-15.09712	76.4956	359.40204

Based on the fit results the noise temperatures have been estimated from the reference load temperature steps and are reported in table

**Table 6-5:** Noise Temperatures estimated from three different fitting function applied on data with REF steps.

	T noise (K) Linear Fit	T noise (K) Parabolic Fit V(T)	T noise (K) Inverse Parabolic Fit T(V)	T noise (K) Parabolic Fit (average)
<b>Detector A</b>	30.41	22.96	20.13	21.55
<b>Detector B</b>	35.44	23.99	17.16	20.58
<b>Detector C</b>	28.59	20.77	17.46	19.11
<b>Detector D</b>	32.06	21.36	15.10	18.23

### 5.2.2.1 Photometric gain with REF variations

The overall photometric gain can be calculated as follows:

- linear fit:  $G0 = a1$  (K/V)
- parabolic fit V(T):  $G1 = dT/dV$  (K/V)
- inverse parabolic fit T(V):  $G2 = dV/dT$  (V/K)

In the case of non linear fit the photometric gain depends on the input temperature. The gain functions are reported hereafter:

#### Photometric Gain from Linear fit

Detector A:  $G0 = 0.00334$  (V/K)  
 Detector B:  $G0 = 0.00348$  (V/K)  
 Detector C:  $G0 = 0.00453$  (V/K)  
 Detector D:  $G0 = 0.00426$  (V/K)

#### Photometric Gain from Parabolic V(T) fit

Detector A:  $G1 = 0.0039 - 2.81E-05 * T$  (V/K)  
 Detector B:  $G1 = 0.00433 - 4.31E-05 * T$  (V/K)  
 Detector C:  $G1 = 0.00542 - 4.47E-05 * T$  (V/K)  
 Detector D:  $G1 = 0.00537 - 5.58E-05 * T$  (V/K)



### 5.2.3 Sky Temperature Steps

The temperature sensor used for the analysis is the SMON\_TMP (ID = 09) which is the thermometer located on the Eccosorb SKY LOAD pyramids. Standard deviation of T and V has not taken into account on the fit.

Data set 044LFI26\_RCA\_FM\_LIS\_200605020246 from 24000 to 24600<sup>1</sup>

Data set 044LFI26\_RCA\_FM\_LIS\_200605010106 from 4500 to 5100 and from 20800 to 21400

Data set 044LFI26\_RCA\_FM\_LIS\_200605010940 from 5900 to 6500 and from 21900 to 22500

Data set 044LFI26\_RCA\_FM\_LIS\_200605011813 from 7400 to 8000 and from 23900 to 24500

Using the RaNa routine `receiver_basic_properties` the temperature (physical) and the voltages have been carried out for each single data file. Then all the values have been combined to perform the fits (in IDL) outside the RaNa environment. The data are reported in the following tables

*Table 6-6: Input data as derived from `receiver_basic_properties` RaNa routine used to perform the fits. Only T change and Vchange data have been used. Temperatures are in Kelvin, Voltages in Volts.*

Detector A				Detector B			
Tchange SKY	Tfixed REF	Vchange	Vfixed	Tchange SKY	Tfixed REF	Vchange	Vfixed
13.408719	8.5640602	0.13534596	0.12612335	13.408719	8.5640602	0.15548713	0.14807330
16.268000	8.5502577	0.14559671	0.12660978	16.268000	8.5502577	0.16655397	0.14846163
19.427620	8.7935648	0.15754849	0.12874723	19.427620	8.7935648	0.17924334	0.15059198
22.601049	9.6386099	0.16867757	0.13252871	22.601049	9.6386099	0.19082749	0.15450276
25.768988	10.502756	0.17895373	0.13596351	25.768988	10.502756	0.20133130	0.15796505
28.954819	11.362653	0.18942235	0.13963884	28.954819	11.362653	0.21199042	0.16171523
33.861866	12.658234	0.20539322	0.14561403	33.861866	12.658234	0.22798208	0.16777854
Detector C				Detector D			
Tchange SKY	Tfixed REF	Vchange	Vfixed	Tchange SKY	Tfixed REF	Vchange	Vfixed
13.408719	8.5640602	0.18072263	0.16235309	13.408719	8.5640602	0.18385409	0.16666709
16.268000	8.5502577	0.19471186	0.16268225	16.268000	8.5502577	0.19745962	0.16709130
19.427620	8.7935648	0.21090623	0.16519876	19.427620	8.7935648	0.21265391	0.16931588
22.601049	9.6386099	0.22589365	0.17002352	22.601049	9.6386099	0.22661113	0.17386342
25.768988	10.502756	0.23954788	0.17429359	25.768988	10.502756	0.23934733	0.17800757
28.954819	11.362653	0.25346631	0.17894373	28.954819	11.362653	0.25215468	0.18242134
33.861866	12.658234	0.27461768	0.18650918	33.861866	12.658234	0.27132590	0.18958374

As in the previous case (Reference steps) the following fits have been performed (V is voltage in Volt and T is the input antenna temperature in Kelvin):

- linear fit:  $V = a_0 + a_1 * T$
- parabolic fit V(T):  $V = a_0 + a_1 * T + a_2 * T^2$
- inverse parabolic fit T(V):  $T = a_0 + a_1 * V + a_2 * V^2$

<sup>1</sup> This point is not sequential w.r.t. to the others. It has been checked that this point does not affect the noise temperature calculation



The parameters of the linear and parabolic fits have been reported hereafter. Note that all the fits have been performed in antenna temperature and not in physical temperature.

**Table 6-7:** Fitting parameters for SKY steps.

	Linear		Parabolic V(T)			Inverse Parabolic T(V)		
	a0	a1	a0	a1	a2	a0	a1	a2
<b>Detector A</b>	0.093806212	0.0034262109	0.086456511	0.0041442143	-1.5980401e-005	-16.011323	155.83204	399.62042
<b>Detector B</b>	0.11302011	0.0035437111	0.10180516	0.0046393166	-2.4384586e-005	-11.928576	70.715667	551.47662
<b>Detector C</b>	0.12534138	0.0045906124	0.11351827	0.0057456289	-2.5706879e-005	-13.716812	96.202260	267.27798
<b>Detector D</b>	0.13279331	0.0042728655	0.11863556	0.0056559566	-3.0783075e-005	-10.836477	53.356924	396.84685

Based on the fit results the noise temperatures have been estimated from the reference load temperature steps and are reported in table

**Table 6-8:** Noise Temperatures estimated from three different fitting function applied on data with REF steps.

	T noise (K) Linear Fit	T noise (K) Parabolic Fit V(T)	T noise (K) Inverse Parabolic Fit T(V)	T noise (K) Parabolic Fit (average)
<b>Detector A</b>	27.38	19.41	16.01	17.71
<b>Detector B</b>	31.89	19.87	11.93	15.90
<b>Detector C</b>	27.30	18.26	13.72	15.99
<b>Detector D</b>	31.08	19.01	10.84	14.92

An additional extrapolation has been performed in the following way: from the parabolic fit  $V = f(T_{ant})$  the voltage and gain at  $T_{ant} = 0$  have been calculated. Then the Noise temperature has been calculated as  $V(0)/G$ . Hereafter the results:

	Tnoise linearly extrapolated form $T_{ant} = 0$
<b>Detector A</b>	20.86
<b>Detector B</b>	21.94
<b>Detector C</b>	19.76
<b>Detector D</b>	20.98

### 5.2.3.1 Photometric Gain with SKY variations

The overall photometric gain can be calculated as follows:

- linear fit:  $G0 = a1 \text{ (K/V)}$
- parabolic fit V(T):  $G1 = dT/dV \text{ (K/V)}$
- inverse parabolic fit T(V):  $G2 = dV/dT \text{ (V/K)}$



In the case of non linear fit the photometric gain depends on the input temperature. The gain functions are reported hereafter:

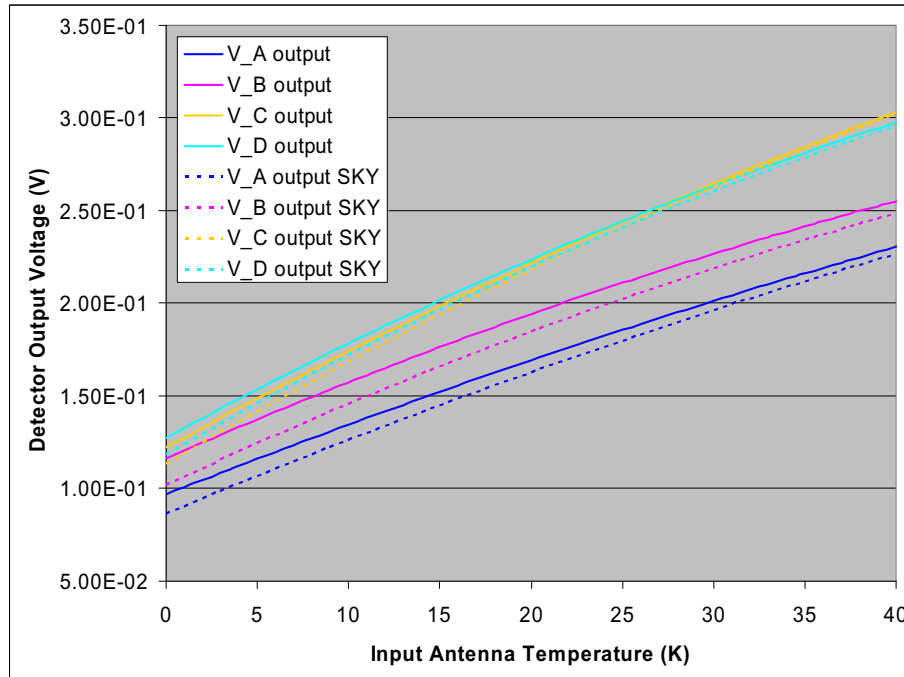
Photometric gain from linear fit

- Detector A:  $G_0 = 0.0034262109 \text{ (V/K)}$
- Detector B:  $G_0 = 0.0035437111 \text{ (V/K)}$
- Detector C:  $G_0 = 0.0045906124 \text{ (V/K)}$
- Detector D:  $G_0 = 0.0042728655 \text{ (V/K)}$

Photometric gain from parabolic  $V = f(T)$  fit

- Detector A:  $G_1 = 0.004144214 - 3.20E-05 * T \text{ (V/K)}$
- Detector B:  $G_1 = 0.004639317 - 4.88E-05 * T \text{ (V/K)}$
- Detector C:  $G_1 = 0.005745629 - 5.14E-05 * T \text{ (V/K)}$
- Detector D:  $G_1 = 0.005655957 - 6.16E-05 * T \text{ (V/K)}$

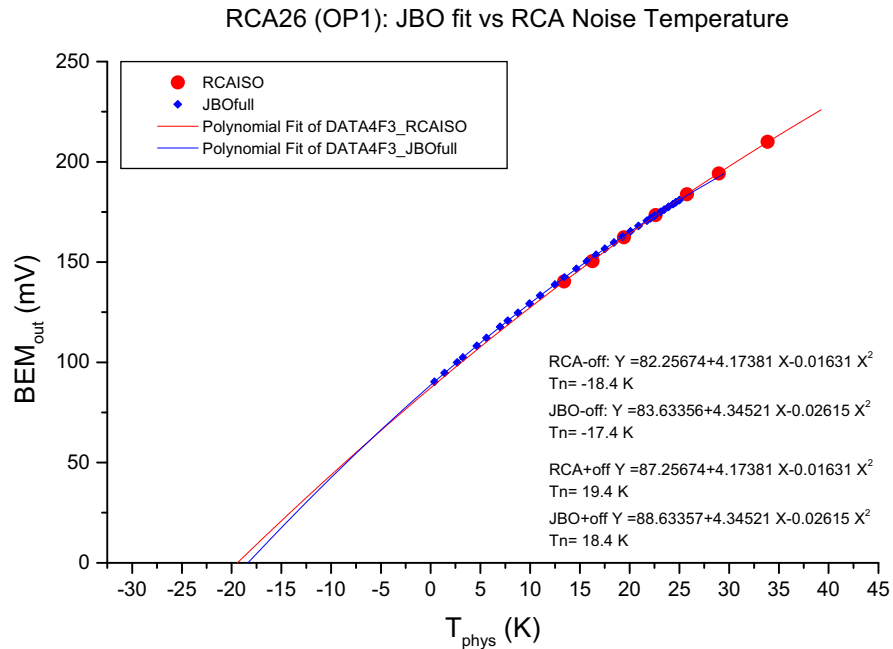
Here we compare the calibration curve  $V = f(T)$  obtained with parabolic fit on data with REF steps with the same curve with SKY steps.



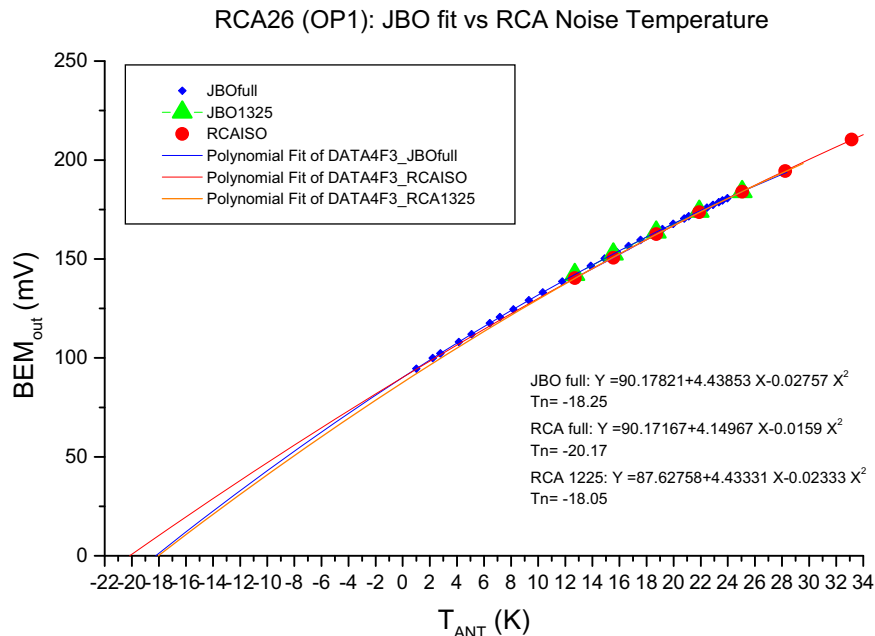
**Figure 6-3:** Calibration functions as derived both from REF steps (continuous line) and from SKY steps (dashed line) using parabolic fit  $T = f(V)$



## 5.2.4 Comparison between RCA data and data extrapolated from measurements on FEM 4F3



**Figure 6-4:** noise temperature based on physical temperatures (both FEM stand alone noise temperature used to calibrate the x-axis and values on x-axis itself); results from removing, or not, BEM offset, are presented. The effect of removing is that of lowering noise temperature by about 1K;



**Figure 6-5:** plot is evaluated converting all temperatures in antenna temperature before doing any extrapolation; as FEM noise temperature, the average noise temperature measured on OP1 and corrected for isolation (14.1K) was used (PL-LFI-



*JBO-RP-099). Also RCA data have been corrected taking into account non perfect isolation (also if the correction is weak). Two extrapolations have been considered for RCA data: the former (RCAfull) considering the full data set (from 13K to 33 K about) ; the latter (RCA1325), considering only the points in the range overlapping with JBO measurements (from 13K to 25K about). For JBO data, only the full data set is here considered (ranging from 0K to 25K about). BEM offset has not been removed.*

The comparison plots shown above (below) are drawn following the same method described in chapter 11 of PL-LFI-PST-TN-073 . §11.1 and 11.2. Numbers found here are in agreement with those reported in the Technical Note.

The basic steps of the method can be summarized in the following terms.

During JBO test campaign on FEM 4F3 (January '06), the FEM was tested coupled with a BEM representative of the 44GHz flight model units: BEM\_44\_B3\_DC. It has not exactly the same architecture of the FM units but should have roughly comparable performance.

The full system has a non-linear response (that means the Voltage measured at the terminals of the BEM is not linearly proportional to the power entering the BEM), such as we say it works in a 'compressed' regime. A dedicated test was performed to estimate the degree of non-linearity and to correct noise temperatures evaluated just by using Y-factor method.

Test was operated using a variable attenuator interposed between the FEM and the BEM. At first, the total power exiting the FEM, for each position of the attenuator, was measured using a power meter, in order to characterise the net power entering the BEM; then, the voltage at the terminals of the BEM was recorded, for each level of attenuation.

In this way, a normalized diagram attenuation A (A=0dB corresponds to attenuation 0) vs  $V_{JBO}^*$  was traced, where  $V_{JBO}^* = V_{out} - V_{off}$  (being  $V_{off}$  the BEM offset measured when FEM currents are switched off)..The best fit of this curve, as expected from a compressed regime, is a parabola.

The normalized input power,  $P_{in}$ , was then converted into thermodynamic temperature, basing on the noise temperature stand-alone measurements performed on the FEM, for that output  $O_{Pi}$ , as follows:

$$T(K)_{OPi} = (T_n + 25K) \cdot [X - T_n / (T_n + 25K)], \quad X = 10^{(A/10)}$$

The method using the variable attenuator allows to reach power inputs corresponding to  $T_{LOAD} = 0K$  (when A=-4.25 dB is applied).

$V_{JBO}^*$  measured at 25 K has been compared with  $V_{RCA}^*$  obtained, at the same temperature, from RCA tests (where  $V_{RCA}^*$  is the total voltage minus the BEM offset): in this way, the ratio  $S_{25K}$  was evaluated, converting  $V_{JBO}^*$  into  $V_{JBO-RCA}^*$  :

$$V_{JBO-RCA}^* = S_{25K} \cdot V_{JBO}^*$$

At the end, two curves have been traced, depending on the BEM offset, measured from RCA tests, has been re-added or not: interception of each curve with the T axis (when V=0) provides the sought noise temperature.

Main limits of this method are:

- the x axis (temperature) calibration of the T-V plot requires an indirect measurement (FEM stand alone noise temperature ); FEM noise temperature is evaluated in the range 39.6 GHz-48.4 GHz.
- ➔ the error committed is at the first order equal to the uncertainty on FEM stand alone noise temperature. Indirect measurements using a filter have shown that only a small amount (about 0.7 dB) of the power coming from outside the FEM's nominal bandwidth enters the BEM.
- loss into transmission waveguides (from FEM to BEM) is not considered.



- losses of about 1-2 dB follow the signal amplification in the FEM: their impact can be considered negligible (and of the same order of RCA setup)
- BEM used is only roughly representative of the FM units.
- measurements reported in PL-LFI-PST-TN-073 using two different representative BEM units BEM\_44\_B3\_DC and BEM\_44\_B4\_DC, provided comparable results.

### 5.2.5 Consistency of the Results based on SKY steps

The white noise limit has been calculated and compared with the requirement. The white noise limit is defined at a given SKY temperature as follows:

$$Eq. 1: \quad \Delta T = \sqrt{2} \cdot \frac{T_{SKY} + T_{SYS}}{\sqrt{B}} \cdot 1000 \left[ \text{mK} \cdot \sqrt{\text{sec}} \right]$$

where B is the bandwidth [Hz],  $\tau$  is the integration time [sec],  $T_{SKY}$  and  $T_{SYS}$  are the Skyload antenna temperature [K] and noise system temperature [K] respectively.

From measurements the white noise limit is calculated as follows:

$$Eq. 2: \quad \Delta T = G[K/V] \cdot \frac{1}{\sqrt{2}} \cdot WN \cdot \sqrt{\frac{\tau}{\tau - \tau_{BT}}}$$

where  $WN$  is the white noise as derived from RaNA,  $\tau$  is the 122 microSec (1/8KHz) integration time and  $\tau_{BT}$  is the blanking time (7.5 microSec). G is the gain (K/V) which needs to be known from RCA\_TNG tests.

The requirements have been calculated assuming  $T_{sys} = 16.6$  Kelvin and  $B = 8.8$  GHz (see [AD 2]), while the white noise limit from measurements has been derived in three ways:

1. From the  $T_{sys}$  and B derived from tests applying the Eq. 1.  $T_{sys}$  values were obtained from parabolic fit V(T) and B were obtained from RCA\_SPR test
2. Directly From WN measurements applying the Eq. 2 where  $WN$  is the white noise level derived from RaNA FFT module when the detector output is calibrated. Firstly the white noise limit has been derived from *RaNA\_FFT* module selecting a stable (~600 sec) calibrated acquisition data chunk. The White noise of differenced calibrated<sup>2</sup> detectors has been selected (A-B and C-D). Then the number has been corrected by the Blanking time.
3. White noise derived from B obtained from WN level (from RaNA FFT) and  $T_{sys}$  from LIS results.

<sup>2</sup> The calibration has been obtained in the following way:



Note that the consistency check has been repeated also using data with SKY = 20K and REF = 20K. Moreover the consistency check has been performed also using the noise temperatures derived from linear extrapolation at  $T_{in} = 0$ .

**Table 6-9:** white noise as derived from measurements ( $T_{sys}$ ,  $B$  from SPR, calibrated WN) compared with the requirements

	Requirement	From Measured $T_{sys}$ & $B$	Ratio over requirement	From Data After calibration	Ratio over requirement	Consistency ratio
	mK* $\sqrt{s}$	mK* $\sqrt{s}$		mK* $\sqrt{s}$		
<b>SKY = 13.32 K REF = 8 K</b>						
Detector A B	0.43551303	0.60996581	1.40	0.66082433	1.52	1.08
Detector C D		0.62667373	1.42	0.62041602	1.44	0.99
<b>SKY = 20.22 K REF = 20 K</b>						
Detector A B	0.53948136	0.74171627	1.37	0.73381244	1.36	0.99
Detector C D		0.76653346	1.42	0.71375301	1.32	0.93

**Table 6-10:** white noise as derived from measurements ( $T_{sys}$ ,  $B$  from WN diff, calibrated WN) compared with the requirements

	Requirement	From Measured $T_{sys}$ & $B$	Ratio over requirement	From Data After calibration	Ratio over requirement	Consistency ratio
	mK* $\sqrt{s}$	mK* $\sqrt{s}$		mK* $\sqrt{s}$		
<b>SKY = 13.32 K REF = 8 K</b>						
Detector A B	0.43551303	0.60339507	1.39	0.66082433	1.52	1.10
Detector C D		0.54623177	1.25	0.62041602	1.42	1.14
<b>SKY = 20.22 K REF = 20 K</b>						
Detector A B	0.53948136	0.73372627	1.36	0.73381244	1.36	1.00
Detector C D		0.66813863	1.24	0.71375301	1.32	1.07

**Table 6-11:** white noise as derived from measurements ( $T_{sys}$  from linear extrapolation at  $T_{in} = 0$ ,  $B$  from SPR, calibrated WN) compared with the requirements

	Requirement	From Measured $T_{sys}$ & $B$	Ratio over requirement	From Data After calibration	Ratio over requirement	Consistency ratio
	mK* $\sqrt{s}$	mK* $\sqrt{s}$		mK* $\sqrt{s}$		
<b>SKY = 13.32 K REF = 8 K</b>						
Detector A B	0.43551303	0.64358888	1.48	0.66082433	1.52	1.03
Detector C D		0.66183382	1.52	0.62041602	1.42	0.94
<b>SKY = 20.22 K REF = 20 K</b>						
Detector A B	0.53948136	1.43719394	1.44	0.73381244	1.36	0.95
Detector C D		0.80159223	1.49	0.71375301	1.32	0.89

Expected White noise at Flight conditions has been calculated using Eq. 1 with  $T_{noise}$  from parabolic  $V(T)$  fit and  $B$  derived from SPR tests because this pair gives the best consistency ratio. Here the results:



**Table 6-12: white noise extrapolated at Flight conditions (SKY = 2.73 K) compared (Tsys from parabolic V(T) fit, B from SPR) compared with the requirements**

	Requirement	From Measured Tsys & B	Ratio over requirement	From Data After calibration	Ratio over requirement	Consistency ratio
	mK* $\sqrt{\text{s}}$	mK* $\sqrt{\text{s}}$		mK* $\sqrt{\text{s}}$		
<b>EXTRAPOLATED AT FLIGHT CONDITIONS</b>						
<b>Detector A B</b>	0.27752534	0.40976110	1.48	N/A	N/A	N/A
<b>Detector C D</b>		0.41430035	1.49	N/A	N/A	N/A

Tsys that gives consistency ratio = 1 (beta from SPR test, value is an average of both channels)						
<i>beta-A (GHz)</i>		6.10				
<i>beta-B (GHz)</i>		4.86				
<b><i>beta A-B (GHz)</i></b>		<b>5.48</b>				
<b><i>Optimal noise temperature</i></b>		<b>22.30</b>		<i>1.00006331</i>		
beta that gives consistency ratio = 1 (Tsys from parabolic fit, value is an average of both channels)						
<i>Tsys-A (K)</i>		19.41				
<i>Tsys-B (K)</i>		19.87				
<b><i>Tsys A-B (K)</i></b>		<b>19.64</b>				
<b><i>Optimal eff bandwidth</i></b>		<b>4.67</b>		<i>1.00011213</i>		

Tsys that gives consistency ratio = 1 (beta from SPR test, value is an average of both channels)						
<i>beta-C (GHz)</i>		4.26				
<i>beta-D (GHz)</i>		5.48				
<b><i>beta C-D (GHz)</i></b>		<b>4.87</b>				
<b><i>Optimal noise temperature</i></b>		<b>18.30</b>		<i>1.00085681</i>		
beta that gives consistency ratio = 1 (Tsys from parabolic fit, value is an average of both channels)						
<i>Tsys-C (K)</i>		18.26				
<i>Tsys-D (K)</i>		19.01				
<b><i>Tsys C-D (K)</i></b>		<b>18.64</b>				
<b><i>Optimal eff bandwidth</i></b>		<b>4.97</b>		<i>1.00012717</i>		

### 5.2.6 Consistency of the Results based on REF steps

Input data

	Tn Linear Fit	Tn Parabolic Fit (V/K)	Tn Parabolic Fit (K/V)	Tn Parabolic Fit (average)
<b>Detector A</b>	30.4072	22.9598	20.1343	21.54705
<b>Detector B</b>	35.4397	23.9945	17.1613	20.5779



Detector C	28.5894	20.7678	17.4618	19.1148
Detector D	32.0563	21.3599	15.0971	18.2285

	SPR Bandwidth	WN Bandwidth @ 8 K	WN Bandwidth @ 20 K
Detector A	6.10	5.67	6.61
Detector B	4.86	5.52	6.85
Detector C	4.26	5.01	5.62
Detector D	5.48	7.40	8.42

Here we report the final results of the consistency check on the reference load.

Ch Id	WN <sub>req</sub> @ 8K (mK*sqrt(s))	WN <sub>mis</sub> @ 8K (mK*sqrt(s))	Ratio over requirements	WN <sub>req</sub> @ 20K (mK*sqrt(s))	WN <sub>mis</sub> @ 20K (mK*sqrt(s))	Ratio over requirement	Consistency Ratio
(A+B)/2	0.35564120	0.63838232	1.80	0.53612862	0.82947339	1.55	
(C+D)/2	0.35564120	0.55015543	1.55	0.53612862	0.80471510	1.50	

Ch Id	Tn @ 8K with BW from SPR test	Tn @ 8 K with BW from spectral analysis
(A+B)/2	26.25	26.75
(C+D)/2	20.1	23.8

Ch Id	Tn @ 20K with BW from SPR test	Tn @ 20 K with BW from spectral analysis
(A+B)/2	24.45	23.5
(C+D)/2	20.75	27.5

Ch Id	BW @ 8K with Tn from Parabolic fit	BW @ 20K with Tn from Parabolic fit
(A+B)/2	3.9	4.75
(C+D)/2	4.35	4.375

### 5.3 RCA\_SPR: BANDPASS MEASUREMENT

SEE ANNEX RCA26\_SPR\_1838.pdf

## 6 NOISE PROPERTIES

### 6.1 RCA\_STN

Long acquisition time has been performed with the aim to derive noise spectra.

The data set analysed are

044LFI26\_RCA\_FM\_ST3\_200604271919

<sup>3</sup> Thanks to ESA – ESTEC

<sup>4</sup> Thanks to Segio Mariotti INAF/IRA - Bologna

<sup>5</sup> Thanks to ESA – ESTEC



044LFI26\_RCA\_FM\_ST3\_200604280358

The temperature step sequence is reported in Table 7-1.

Table 7-1: Reference Temperature steps for Noise properties test (STn)

SKY Temperature	REF Temperature	Duration
13.0 K	8.0 K	≤ 2 hours
13.5 K	15.0 K	≤ 2 hours
14.1 K	20.0 K	≤ 2 hours
20.0 K	20.0 K	≤ 2 hours

RaNA reports (044LFI26\_RCA\_FM\_ST3\_200604271919 and 044LFI26\_RCA\_FM\_ST3\_200604280358) have been uploaded on max.iasfbo.inaf.it (directory RCA026 Docs).

### 6.1.1 One-Over-F Noise

A fourier transform has been applied on data to obtain the 1/f knee frequency and noise properties. The following data set have been used:

13.0 / 8.0 Selected from **3400 – 7000** sec, bin 10 for FFT and 1/f from file  
044LFI26\_RCA\_FM\_ST3\_200604271919  
13.5 / 15.0 Selected from **10400 – 14000** sec, bin 10 for FFT and 1/f from file  
044LFI26\_RCA\_FM\_ST3\_200604271919  
14.1 / 20.0 Selected from **18000 – 21600** sec, bin 10 for FFT and 1/f from file  
044LFI26\_RCA\_FM\_ST3\_200604271919  
20.0 / 20.0 Selected from **3100 – 6700** sec, bin 10 for FFT and 1/f from file  
044LFI26\_RCA\_FM\_ST3\_200604280358

In the following table the 1/f characteristics obtained by an optimized fitting is reported. The numbers of point used for the low frequency fit is reported for each detector. BIN = 10 is used (fsampl = 409.600).

T sky = 13.0 K T ref = 8.0 K	Detector A	Detector B	Detector C	Detector D
N points	100	19	50	50
1/f knee frequency	0.0210287	0.0232209	0.0153601	0.0230673
R factor	1.0854257	1.0608196	1.1305732	1.1190609
1/f Slope	-1.01830	-0.718313	-0.671415	-0.809027

T sky = 13.5 K T ref = 15.0 K	Detector A	Detector B	Detector C	Detector D
N points	100	70	80	100
1/f knee frequency	0.021096363	0.0158893	0.0143715	0.0157626
R factor	0.92194174	0.90872039	0.94093884	0.94027270
1/f Slope	-1.1251525	-1.01465	-1.32050	-1.21265

T sky = 14.1 K T ref = 20.0 K	Detector A	Detector B	Detector C	Detector D
N points	90	90	95	100
1/f knee frequency	0.031423496	0.030098341	0.022639367	0.028690827



R factor	0.84759331	0.83985784	0.85669811	0.86137225
1/f Slope	-1.0363142	-1.2235180	-1.2066979	-1.2795676

T sky = 20.0 K T ref = 20.0 K	Detector A	Detector B	Detector C	Detector D
N points	50	50	21	50
1/f knee frequency	0.012900874	0.0093976476	0.0084720573	0.013875725
R factor	0.96583587	0.95175796	0.98396163	0.98202678
1/f Slope	-1.1665125	-1.3476651	-1.1586086	-1.5453465

Further checks have been done on the following data:

12.8 / 9.5 Selected from **0 – 3600** sec, bin 10 for FFT and 1/f from file

044LFI26\_RCA\_FM\_ST3\_200604271919

T sky = 13.0 K T ref = 8.0 K	Detector A	Detector B	Detector C	Detector D
N points	100	100	130	100
1/f knee frequency	0.040787662	0.0349108	0.0339042	0.0393686
R factor	1.0885601	1.0636618	1.1339902	1.1223192
1/f Slope	-1.2377347	-1.32387	-1.52258	-1.55827

12.8 / 9.5 Selected from **5200 – 7000** sec, bin 10 for FFT and 1/f from file

044LFI26\_RCA\_FM\_ST3\_200604271919

T sky = 13.0 K T ref = 8.0 K	Detector A	Detector B	Detector C	Detector D
N points	31	35	30	35
1/f knee frequency	0.021111714	0.018102599	0.020513719	0.021126425
R factor	1.0847963	1.0602738	1.1299140	1.1184345
1/f Slope	-0.97392841	-1.0176185	-1.0631538	-0.90010935

12.8 / 9.5 Selected from **3400 – 5200** sec, bin 10 for FFT and 1/f from file

044LFI26\_RCA\_FM\_ST3\_200604271919

T sky = 13.0 K T ref = 8.0 K	Detector A	Detector B	Detector C	Detector D
N points	50	30	130	42
1/f knee frequency	0.022525885	0.0324313	0.031853508	0.019194183
R factor	1.0860706	1.0613784	1.1312481	1.1197024
1/f Slope	-1.2138895	-0.87121421	-0.56872296	-0.89623479

## 6.1.2 White Noise Level and Equivalent Bandwidth

The white noise level has been calculated with the *RaNA\_FFT* module using the high frequency part of the amplitude spectrum. From the white noise limit the equivalent bandwidth has been derived. Same data stream as the 1/f calculation has been used. Data were not binned and 10 minutes have been taken for each reference temperature step. For each step the last 600 seconds of the data taken for 1/f noise have been taken for this analysis.



T sky = 13.0 K T ref = 8.0 K	White noise level [V/Sqrt(Hz)]			Effective bandwidth [GHz]		
	<i>Sky</i>	<i>Load</i>	<i>Diff</i>	<i>Sky</i>	<i>Load</i>	<i>Diff</i>
DETECTOR A	3.3778945e-006	3.2938292e-006	4.9229402e-006	6.02	5.38	5.67
DETECTOR B	3.8793142e-006	3.9531096e-006	5.7092196e-006	5.98	5.13	5.52
DETECTOR C	4.9403358e-006	4.3891669e-006	7.0067646e-006	5.04	5.00	5.01
DETECTOR D	4.1146511e-006	3.7222941e-006	5.8622712e-006	7.51	7.34	7.40

T sky = 13.5 K T ref = 15.0 K	White noise level [V/Sqrt(Hz)]			Effective bandwidth [GHz]		
	<i>Sky</i>	<i>Load</i>	<i>Diff</i>	<i>Sky</i>	<i>Load</i>	<i>Diff</i>
DETECTOR A	3.5618125e-006	3.6950930e-006	4.9270648e-006	5.88	6.40	6.14
DETECTOR B	3.9757728e-006	4.4293495e-006	5.6561900e-006	6.11	5.94	6.04
DETECTOR C	5.0578695e-006	5.2592862e-006	7.0887751e-006	5.15	5.35	5.24
DETECTOR D	4.2074265e-006	4.3931513e-006	5.8925307e-006	7.66	7.92	7.81

T sky = 14.1 K T ref = 20.0 K	White noise level [V/Sqrt(Hz)]			Effective bandwidth [GHz]		
	<i>Sky</i>	<i>Load</i>	<i>Diff</i>	<i>Sky</i>	<i>Load</i>	<i>Diff</i>
DETECTOR A	3.6039733e-006	4.0225285e-006	4.9631779e-006	6.05	6.73	6.38
DETECTOR B	4.0222370e-006	4.6536823e-006	5.6226059e-006	6.24	6.59	6.39
DETECTOR C	5.1444410e-006	5.7445899e-006	7.1121956e-006	5.19	5.65	5.43
DETECTOR D	4.2707972e-006	4.7212675e-006	5.9073985e-006	7.74	8.51	8.09

T sky = 20.0 K T ref = 20.0 K	White noise level [V/Sqrt(Hz)]			Effective bandwidth [GHz]		
	<i>Sky</i>	<i>Load</i>	<i>Diff</i>	<i>Sky</i>	<i>Load</i>	<i>Diff</i>
DETECTOR A	3.9876456e-006	4.0945225e-006	5.6128202e-006	6.55	6.65	6.61
DETECTOR B	4.3221660e-006	4.6650581e-006	6.1925689e-006	7.03	6.66	6.85
DETECTOR C	5.7716015e-006	5.7652836e-006	8.0918970e-006	5.52	5.71	5.62
DETECTOR D	4.7172566e-006	4.7752907e-006	6.6447147e-006	8.35	8.44	8.42

## 6.2 RCA\_UNC: UNCHOPPED DATA

Noise properties have been derived also from unchopped data, i.e. with all the phase switches off. The knee frequencies reported in the tables below are in Hz. The following data set have been analysed:

- 044LFI26\_RCA\_FM\_UNC\_200605021247
- 044LFI26\_RCA\_FM\_UNC\_200605021346
- 044LFI26\_RCA\_FM\_UNC\_200605021453
- 044LFI26\_RCA\_FM\_UNC\_200605021546

The corresponding RaNA report sare available on max server (max.iasfbo.inaf.it).

### 6.2.1 PS/SW In1 diode reverse, In2 diode forward on all channels

13.0 / 8.5 Selected from **60 – 3360** sec, bin 10 for FFT and 1/f from file  
044LFI26\_RCA\_FM\_UNC\_200605021247

T sky = 13.0 K T ref = 8.5 K	Detector A	Detector B	Detector C	Detector D
---------------------------------	------------	------------	------------	------------



	SKY			
N points	30000	15	56	22
1/f knee frequency	17.6259	45.0760	48.0902	96.5309
1/f Slope	-0.686465	-0.744832	-0.655769	-0.668252
	REF			
N points	30000	15	54	22
1/f knee frequency	16.9564	74.5279	42.1125	51.5682
1/f Slope	-0.698877	-0.707348	-0.661480	-0.713696

The white noise level has been calculated with the *RaNA\_FFT* module using the high frequency part of the amplitude spectrum. From the white noise limit the equivalent bandwidth has been derived. Same data stream as the 1/f calculation has been used. Data were not binned and 10 minutes have been taken for each reference temperature step. For each step the last 600 seconds of the data taken for 1/f noise have been taken for this analysis.

T sky = 13.0 K T ref = 8.5 K	White noise level [V/Sqrt(Hz)]			Effective bandwidth [GHz]		
	<i>Sky</i>	<i>Load</i>	<i>Diff</i>	<i>Sky</i>	<i>Load</i>	<i>Diff</i>
	DETECTOR A	3.5106267e-006	3.5172291e-006	4.9698744e-006	6.00	5.98
DETECTOR B	4.1705082e-006	4.1719757e-006	5.9130122e-006	5.06	5.06	5.03
DETECTOR C	5.0891075e-006	5.0810359e-006	7.1957427e-006	5.11	5.13	5.11
DETECTOR D	3.9058343e-006	3.9135742e-006	5.5180042e-006	7.31	7.28	7.32



## 6.2.2 PS/SW In1 diode reverse, In2 diode forward on Channels M2/S2; In1 diode forward, In2 diode reverse on Channels M1/S1

13.0 / 8.5 Selected from **60 – 3660** sec, bin 10 for FFT and 1/f from file  
044LFI26\_RCA\_FM\_UNC\_200605021346

T sky = 13.0 K T ref = 8.5 K	Detector A	Detector B	Detector C	Detector D
<b>SKY</b>				
<b>N points</b>	26	30000	30000	110
<b>1/f knee frequency</b>	134.89595	15.8590 <sup>6</sup>	13.3187	118.425
<b>1/f Slope</b>	-0.62137047	-0.722459	-0.715814	-0.586891
<b>REF</b>				
<b>N points</b>	25	30000	30000	135
<b>1/f knee frequency</b>	72.852824	15.7990	13.6177	108.410
<b>1/f Slope</b>	-0.66189663	-0.725272	-0.710005	-0.592705

The white noise level has been calculated with the *RaNA\_FFT* module using the high frequency part of the amplitude spectrum. From the white noise limit the equivalent bandwidth has been derived. Same data stream as the 1/f calculation has been used. Data were not binned and 10 minutes have been taken for each reference temperature step. For each step the last 600 seconds of the data taken for 1/f noise have been taken for this analysis.

T sky = 13.0 K T ref = 8.5 K	White noise level [V/Sqrt(Hz)]			Effective bandwidth [GHz]		
	<i>Sky</i>	<i>Load</i>	<i>Diff</i>	<i>Sky</i>	<i>Load</i>	<i>Diff</i>
<b>DETECTOR A</b>	3.4307664e-006	3.4308245e-006	4.8534339e-006	5.44	5.44	5.44
<b>DETECTOR B</b>	4.0187820e-006	4.0382886e-006	5.6963278e-006	6.06	6.00	6.03
<b>DETECTOR C</b>	4.6292984e-006	4.6358128e-006	6.5514148e-006	4.98	4.96	4.97
<b>DETECTOR D</b>	4.2299334e-006	4.2214604e-006	5.9783033e-006	7.69	7.72	7.70

<sup>6</sup> The red values are underestimated because the right number of points has not been found.



### 6.2.3 PS/SW In1 diode forward, In2 diode reverse on all channels

13.0 / 8.5 Selected from 0 – 2900 sec, bin 10 for FFT and 1/f from file

044LFI26\_RCA\_FM\_UNC\_200605021453

T sky = 13.0 K T ref = 8.5 K	Detector A	Detector B	Detector C	Detector D
<b>SKY</b>				
<b>N points</b>	63	17	44	62
<b>1/f knee frequency</b>	116.910	121.630	62.9841	118.968
<b>1/f Slope</b>	-0.617764	-0.711161	-0.633328	-0.647501
<b>REF</b>				
<b>N points</b>	63	17	44	62
<b>1/f knee frequency</b>	138.839	87.8341	105.530	193.281
<b>1/f Slope</b>	-0.607330	-0.732438	-0.599384	-0.617691

The white noise level has been calculated with the *RaNA\_FFT* module using the high frequency part of the amplitude spectrum. From the white noise limit the equivalent bandwidth has been derived. Same data stream as the 1/f calculation has been used. Data were not binned and 10 minutes have been taken for each reference temperature step. For each step the last 600 seconds of the data taken for 1/f noise have been taken for this analysis.

T sky = 13.0 K T ref = 8.5 K	White noise level [V/Sqrt (Hz)]			Effective bandwidth [GHz]		
	<i>Sky</i>	<i>Load</i>	<i>Diff</i>	<i>Sky</i>	<i>Load</i>	<i>Diff</i>
<b>DETECTOR A</b>	3.4625990e-006	3.4498742e-006	4.8781785e-006	6.36	6.41	6.41
<b>DETECTOR B</b>	4.0568364e-006	4.0630954e-006	5.7373335e-006	5.41	5.39	5.41
<b>DETECTOR C</b>	5.1064529e-006	5.0860497e-006	7.2131763e-006	5.21	5.25	5.22
<b>DETECTOR D</b>	3.9165013e-006	3.9138098e-006	5.5282504e-006	7.41	7.42	7.44



## 6.2.4 PS/SW In1 diode reverse, In2 diode forward on Channels M1/S1; In1 diode forward, In2 diode reverse on Channels M2/S2

13.0 / 8.5 Selected from 0 – 3300 sec, bin 10 for FFT and 1/f from file  
044LFI26\_RCA\_FM\_UNC\_200605021546

T sky = 13.0 K T ref = 8.5 K	Detector A	Detector B	Detector C	Detector D
<b>SKY</b>				
<b>N points</b>	39	32	14	30000
<b>1/f knee frequency</b>	102.97070	81.462627	216.13030	15.4240 <sup>7</sup>
<b>1/f Slope</b>	-0.65568690	-0.66033746	-0.65470978	-0.752533
<b>REF</b>				
<b>N points</b>	21	32	14	30000
<b>1/f knee frequency</b>	226.67269	54.269254	130.92942	14.9335
<b>1/f Slope</b>	-0.60318721	-0.68950161	-0.68816731	-0.762370

The white noise level has been calculated with the *RaNA\_FFT* module using the high frequency part of the amplitude spectrum. From the white noise limit the equivalent bandwidth has been derived. Same data stream as the 1/f calculation has been used. Data were not binned and 10 minutes have been taken for each reference temperature step. For each step the last 600 seconds of the data taken for 1/f noise have been taken for this analysis.

T sky = 13.0 K T ref = 8.5 K	White noise level [V/Sqrt(Hz)]			Effective bandwidth [GHz]		
	<i>Sky</i>	<i>Load</i>	<i>Diff</i>	<i>Sky</i>	<i>Load</i>	<i>Diff</i>
<b>DETECTOR A</b>	3.3982294e-006	3.3823052e-006	4.8014538e-006	5.56	5.62	5.57
<b>DETECTOR B</b>	3.9997028e-006	4.0168615e-006	5.6658854e-006	6.16	6.11	6.14
<b>DETECTOR C</b>	4.5869545e-006	4.5863146e-006	6.4827402e-006	5.03	5.03	5.04
<b>DETECTOR D</b>	4.2140010e-006	4.2262637e-006	5.9629321e-006	7.73	7.68	7.72

<sup>7</sup> The red values are underestimated because the right number of points has not been found.



## 7 SUSCEPTIBILITY TESTS

Any thermal and electrical variation on the RCA subsystem units produces a variation of the output signal from each of the four detector.

The relationship between the thermal (or electrical variation) and the variation of the output signal is:

$$(\bullet T_{meas}^{param}) = f_{param} \times (\bullet P)$$

where the  $f_{param}$  represents a transfer function that can also be derived from analytical models of the LFI receivers and  $\bullet P$  the variation of the parameter.

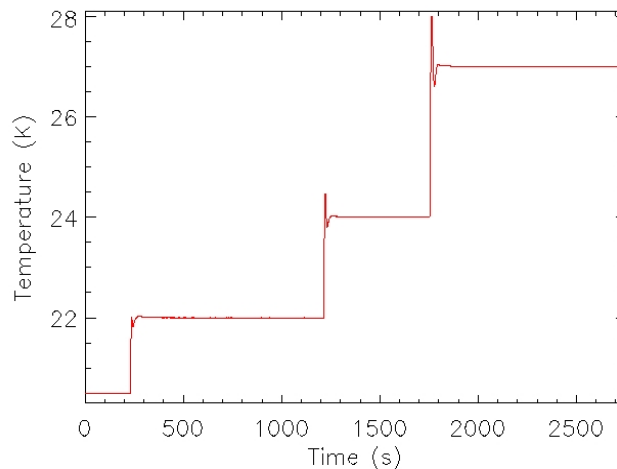
### 7.1 RCA\_THV: SUSCEPTIBILITY TO V-GROOVE TEMPERATURE VARIATIONS

### 7.2 RCA\_THB: SUSCEPTIBILITY TO BEM TEMPERATURE VARIATIONS

### 7.3 RCA\_THF: SUSCEPTIBILITY TO FEM TEMPERATURE VARIATIONS

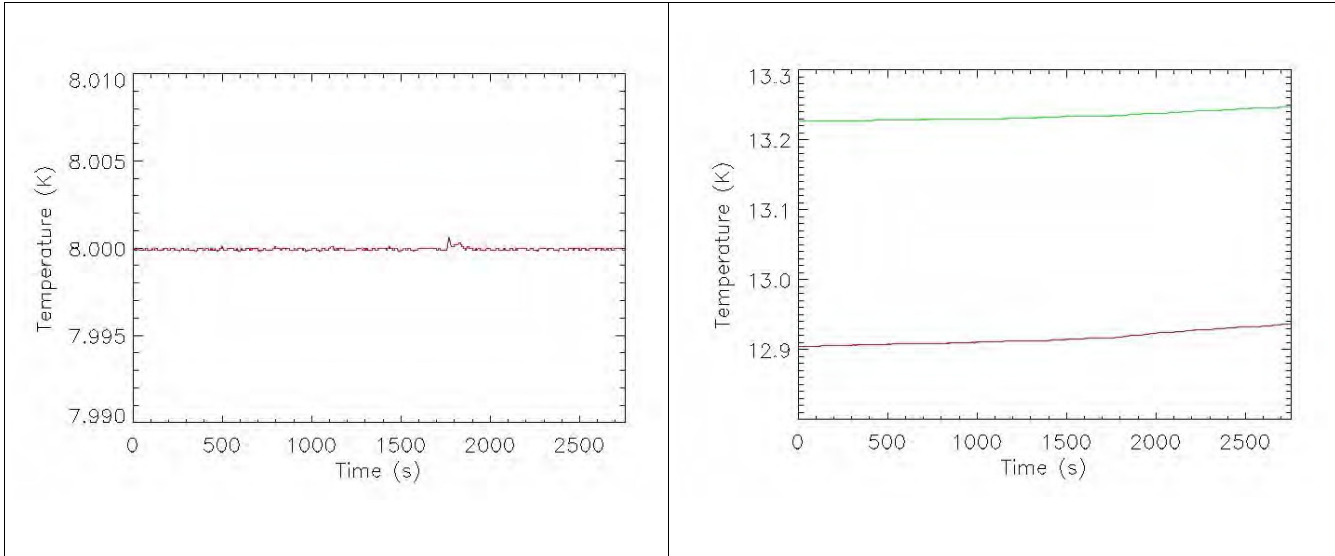
The test has been performed by varying the temperature of the FEM keeping constant the temperatures of the other thermal interfaces.

The temperature of the FEM has been set to 20K (nominal), 22K, 24K, and 27K as seen in Figure -8

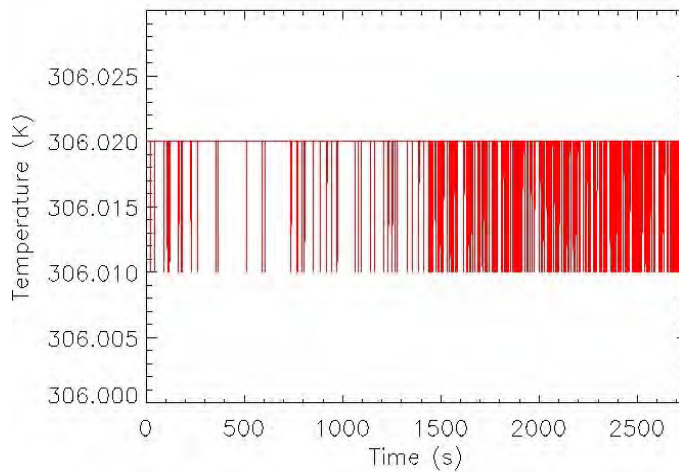


*Figure -8: FEM temperature step during the RCA\_THF test*

The temperature behaviour of the other thermal interfaces are reported in the next figures (Figure -9 and Figure -10) showing the sky load (SKY\_TEMP and SMON\_TMP) and reference load temperatures, and the BEM temperature.



**Figure -9:** Left – Reference Load temperature behaviour during the RCA\_THF test; right – SKY\_TEMP probe (red) and SMON\_TMP probe (green)



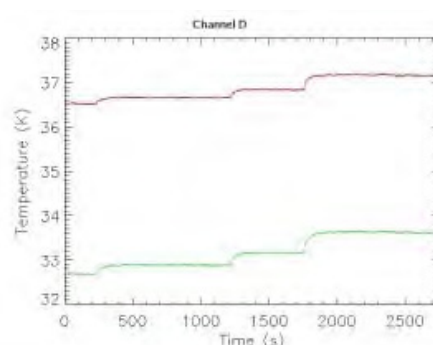
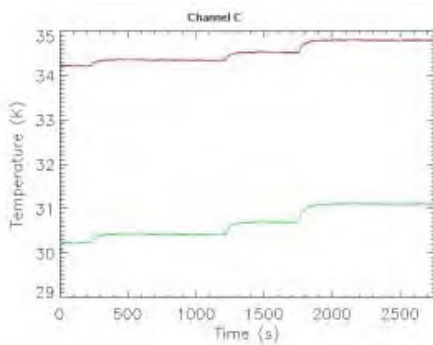
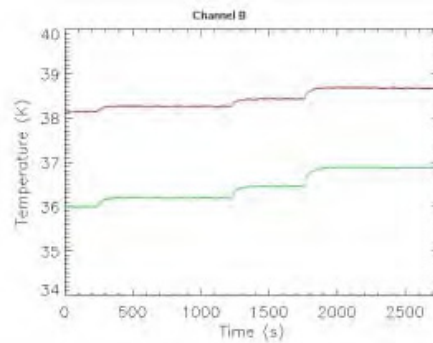
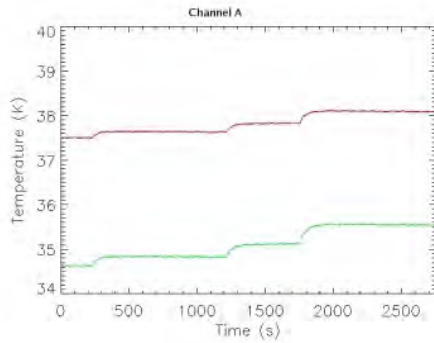
**Figure -10:** BEM temperature behaviour during the RCA\_THF test

To do the analysis, the radiometric output for each channel in the three steps was recorded. We can see the output of the channels in the figures below:

**Figure -11:** Radiometric output of the 4 detectors during the RCA\_THF test. Sky



(red) and Ref (green)



### 7.3.1 Analysis using the SKY\_TEMP probe as sky load temperature:

The default parameters for the four channels are:

	Ch. A	Ch. B	Ch. C	Ch. D
Freq. (GHz)	44			
L <sub>feed-OMT</sub> (dB)	0.1			
L <sub>sk</sub> (dB)	0.1			
r	1.0830277	1.0594471	1.1322518	1.1176707
T <sub>sky</sub> (K)	12.9055			
T <sub>ref</sub> (K)	7.9999			
G <sub>F1</sub> <sup>dB</sup> (dB)	35			
G <sub>F2</sub> <sup>dB</sup> (dB)	35			
T <sub>nF1</sub> (K)	20	20	20	20
T <sub>nF2</sub> (K)	20	20	20	20
$\partial G_{F1}^{dB} / \partial T_{phys}^{FE}$ (dB/K)	-0.05	-0.05	-0.05	-0.05
$\partial G_{F2}^{dB} / \partial T_{phys}^{FE}$ (dB/K)	-0.05	-0.05	-0.05	-0.05



$\partial T_{nF1} / \partial T_{phys}^{FE}$ (K/K)	0.08	0.08	0.08	0.08
$\partial T_{nF2} / \partial T_{phys}^{FE}$ (K/K)	0.08	0.08	0.08	0.08
Gain Calibration Factor (V/K)	0.0035	0.0038	0.005	0.00486

Table -2: Default input parameters for RCA\_THF analysis

Calculating the theoretical and the measured transfer functions with RaNA, we obtain:

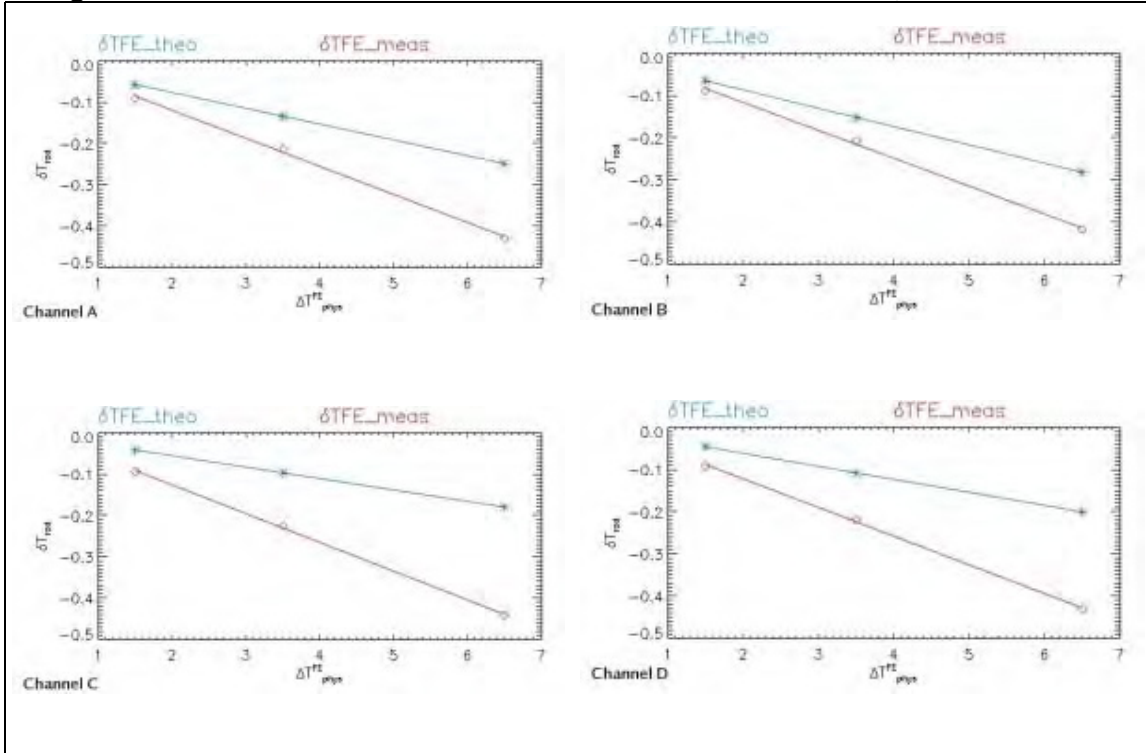


Figure -12: RCA\_THF theoretical (blue) Vs measured (red) transfer function

Table -3: RCA\_THF Analysis Result based on default parameters

	Channel A	Channel B	Channel C	Channel D
$f_{therm}^{front-end}$ (K/K) theoretical	-0.0383	-0.04341	-0.02765	-0.03081
$f_{therm}^{front-end}$ (K/K) measured	-0.06799	-0.06614	-0.06972	-0.06807

The complete RaNA output:

<pre> FEM susceptibility INPUT Frequency (GHz) =      44 Receiver: LFI Channel : A Load correct : Yes r =      1.0830277 Model: FM Gain calibration factor (V/K) = value of RaNA_View LfeedOMT_dB =      0.100000 L4K_dB =      0.100000 GF1_dB =      35 GF2_dB =      35 TnF1_K =      20 TnF2_K =      20         </pre>	<pre> FEM susceptibility INPUT Frequency (GHz) =      44 Receiver: LFI Channel : B Load correct : Yes r =      1.0594471 Model: FM Gain calibration factor (V/K) = value of RaNA_View LfeedOMT_dB =      0.100000 L4K_dB =      0.100000 GF1_dB =      35 GF2_dB =      35 TnF1_K =      20 TnF2_K =      20         </pre>
---	---



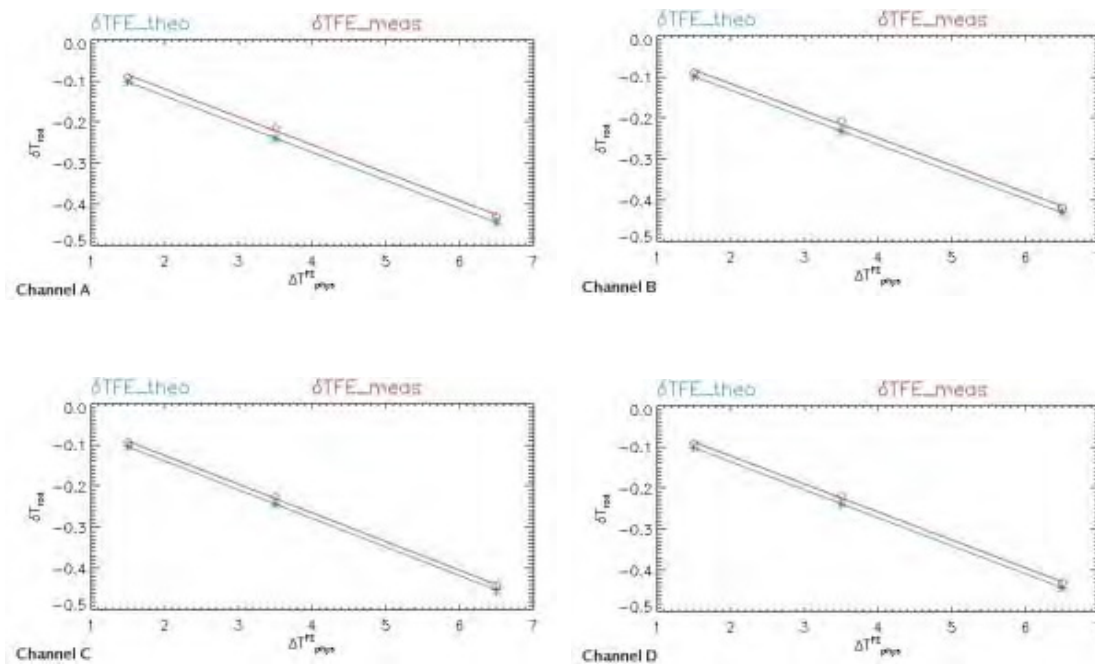
<pre> dGF1_dB_dTFEphys_K = -0.0500000 dGF2_dB_dTFEphys_K = -0.0500000 dTn1_dTFEphys_K = 0.0800000 dTn2_dTFEphys_K = 0.0800000  There are 4 time windows tmin tmax 25.00 211.00 346.00 1203.00 1318.00 1732.00 1913.00 2707.00  Sky Sensor = SKY_TEMP Ref Sensor = REF_TEMP FEM Sensor = FEM_TEMP  SKY_TEMPREF_TEMP FEM_TEMP 12.90548801 7.99992561 20.50028610 12.90922451 7.99997711 22.00064087 12.91474056 7.99996519 24.00156212 12.92889786 7.99997425 27.00092316  Radiometer outputs (K) Tsky Tref 37.503393 34.628286 37.635268 34.833788 37.813190 35.111307 38.077015 35.554044  Tsky-r*Tref -0.090688742 -0.21332812 -0.42899926  OUTPUT ftheo (K/K) fmeas (K/K) -0.038304 -0.067993 </pre>	<pre> dGF1_dB_dTFEphys_K = -0.0500000 dGF2_dB_dTFEphys_K = -0.0500000 dTn1_dTFEphys_K = 0.0800000 dTn2_dTFEphys_K = 0.0800000  There are 4 time windows tmin tmax 25.00 211.00 346.00 1203.00 1318.00 1732.00 1913.00 2707.00  Sky Sensor = SKY_TEMP Ref Sensor = REF_TEMP FEM Sensor = FEM_TEMP  SKY_TEMPREF_TEMP FEM_TEMP 12.90548801 7.99992561 20.50028610 12.90922451 7.99997711 22.00064087 12.91474056 7.99996519 24.00156212 12.92889786 7.99997425 27.00092316  Radiometer outputs (K) Tsky Tref 38.135236 35.995413 38.259913 36.196441 38.419205 36.459620 38.653722 36.878813  Tsky-r*Tref -0.088301141 -0.20783378 -0.41742839  OUTPUT ftheo (K/K) fmeas (K/K) -0.043408 -0.066142 </pre>
<pre> FEM susceptibility INPUT Frequency (GHz) = 44 Receiver: LFI Channel : C Load correct : Yes r = 1.1322518 Model: FM Gain calibration factor (V/K) = value of RaNA_View LfeedOMT_dB = 0.100000 L4K_dB = 0.100000 GF1_dB = 35 GF2_dB = 35 TnF1_K = 20 TnF2_K = 20 dGF1_dB_dTFEphys_K = -0.0500000 dGF2_dB_dTFEphys_K = -0.0500000 dTn1_dTFEphys_K = 0.0800000 dTn2_dTFEphys_K = 0.0800000  There are 4 time windows tmin tmax 25.00 211.00 346.00 1203.00 1318.00 1732.00 1913.00 2707.00  Sky Sensor = SKY_TEMP Ref Sensor = REF_TEMP FEM Sensor = FEM_TEMP  SKY_TEMPREF_TEMP FEM_TEMP 12.90548801 7.99992561 20.50028610 12.90922451 7.99997711 22.00064087 12.91474056 7.99996519 24.00156212 12.92889786 7.99997425 27.00092316  Radiometer outputs (K) Tsky Tref 34.220738 30.223612 34.350506 30.421420 34.523009 30.689473 34.779168 31.106957  Tsky-r*Tref -0.094200633 -0.22520089 -0.44173944  OUTPUT ftheo (K/K) fmeas (K/K) -0.027650 -0.069716 </pre>	<pre> FEM susceptibility INPUT Frequency (GHz) = 44 Receiver: LFI Channel : D Load correct : Yes r = 1.1176707 Model: FM Gain calibration factor (V/K) = value of RaNA_View LfeedOMT_dB = 0.100000 L4K_dB = 0.100000 GF1_dB = 35 GF2_dB = 35 TnF1_K = 20 TnF2_K = 20 dGF1_dB_dTFEphys_K = -0.0500000 dGF2_dB_dTFEphys_K = -0.0500000 dTn1_dTFEphys_K = 0.0800000 dTn2_dTFEphys_K = 0.0800000  There are 4 time windows tmin tmax 25.00 211.00 346.00 1203.00 1318.00 1732.00 1913.00 2707.00  Sky Sensor = SKY_TEMP Ref Sensor = REF_TEMP FEM Sensor = FEM_TEMP  SKY_TEMPREF_TEMP FEM_TEMP 12.90548801 7.99992561 20.50028610 12.90922451 7.99997711 22.00064087 12.91474056 7.99996519 24.00156212 12.92889786 7.99997425 27.00092316  Radiometer outputs (K) Tsky Tref 36.527650 32.681942 36.658009 32.879958 36.835192 33.153305 37.150232 33.624005  Tsky-r*Tref -0.090956591 -0.21928645 -0.43033382  OUTPUT ftheo (K/K) fmeas (K/K) -0.030806 -0.068068 </pre>

To improve the results obtained with the default parameters, I am going to change any of them. In particular, I change the  $\partial G_{FE}^{dB}/\partial T_{phys}^{FE}$  and  $\partial T_{nFE}/\partial T_{phys}^{FE}$ . The best values will be:

**Table -4: Optimized parameters of RCA\_THF test**

	Ch. A	Ch. B	Ch. C	Ch. D
$\partial G_{F1}^{dB}/\partial T_{phys}^{FE}$ (dB/K)	-0.098	-0.079	-0.121	-0.13
$\partial G_{F2}^{dB}/\partial T_{phys}^{FE}$ (dB/K)	-0.098	-0.079	-0.121	-0.13
$\partial T_{nF1}/\partial T_{phys}^{FE}$ (K/K)	0.1	0.1	0.246	0.145
$\partial T_{nF2}/\partial T_{phys}^{FE}$ (K/K)	0.1	0.1	0.246	0.145

and calculating the transfer functions, the new results:



**Figure -13: RCA\_THF theoretical Vs measured transfer function after optimisation of the parameters.**

**Table -5: RCA\_THF Optimal transfer function Vs. theoretical**

	Channel A	Channel B	Channel C	Channel D
$f_{therm}^{front-end}$ (K/K) theoretical	-0.068393	-0.066175	-0.06963	-0.068124



$f_{\text{therm}}^{\text{front-end}}$	(K/K) measured	-0.067993	-0.066142	-0.069716	-0.068068
---------------------------------------	----------------	-----------	-----------	-----------	-----------

The complete RaNA output:

<pre> FEM susceptibility INPUT Frequency (GHz) =      44 Receiver: LFI Channel : A Load correct : Yes r =      1.0830277 Model: FM Gain calibration factor (V/K) = value of RaNA_View LfeedOMT_dB =      0.100000 L4K_dB =      0.100000 GF1_dB =      35 GF2_dB =      35 TnF1_K =      20 TnF2_K =      20 dGF1_dB_dTFEphys_K = -0.0980000 dGF2_dB_dTFEphys_K = -0.0980000 dTn1_dTFEphys_K =      0.100000 dTn2_dTFEphys_K =      0.100000  There are      4 time windows tmin tmax   25.00   211.00   346.00  1203.00   1318.00 1732.00   1913.00 2707.00  Sky Sensor = SKY_TEMP Ref Sensor = REF_TEMP FEM Sensor = FEM_TEMP  SKY_TEMPREF_TEMP FEM_TEMP 12.90548801      7.99992561    20.50028610 12.90922451      7.99997711    22.00064087 12.91474056      7.99996519    24.00156212 12.92889786      7.99997425    27.00092316  Radiometer outputs (K) Tsky Tref   37.503393      34.628286   37.635268      34.833788   37.813190      35.111307   38.077015      35.554044  Tsky-r*Tref -0.090688742 -0.21332812 -0.42899926  OUTPUT ftheo (K/K) fmeas (K/K) -0.068393 -0.067993 </pre>	<pre> FEM susceptibility INPUT Frequency (GHz) =      44 Receiver: LFI Channel : B Load correct : Yes r =      1.0594471 Model: FM Gain calibration factor (V/K) = value of RaNA_View LfeedOMT_dB =      0.100000 L4K_dB =      0.100000 GF1_dB =      35 GF2_dB =      35 TnF1_K =      20 TnF2_K =      20 dGF1_dB_dTFEphys_K = -0.0790000 dGF2_dB_dTFEphys_K = -0.0790000 dTn1_dTFEphys_K =      0.100000 dTn2_dTFEphys_K =      0.100000  There are      4 time windows tmin tmax   25.00   211.00   346.00  1203.00   1318.00 1732.00   1913.00 2707.00  Sky Sensor = SKY_TEMP Ref Sensor = REF_TEMP FEM Sensor = FEM_TEMP  SKY_TEMPREF_TEMP FEM_TEMP 12.90548801      7.99992561    20.50028610 12.90922451      7.99997711    22.00064087 12.91474056      7.99996519    24.00156212 12.92889786      7.99997425    27.00092316  Radiometer outputs (K) Tsky Tref   38.135236      35.995413   38.259913      36.196441   38.419205      36.459620   38.653722      36.878813  Tsky-r*Tref -0.088301141 -0.20783378 -0.41742839  OUTPUT ftheo (K/K) fmeas (K/K) -0.066175 -0.066142 </pre>
<pre> FEM susceptibility INPUT Frequency (GHz) =      44 Receiver: LFI Channel : C Load correct : Yes r =      1.1322518 Model: FM Gain calibration factor (V/K) = value of RaNA_View LfeedOMT_dB =      0.100000 L4K_dB =      0.100000 GF1_dB =      35 GF2_dB =      35 TnF1_K =      20 TnF2_K =      20 dGF1_dB_dTFEphys_K = -0.121000 dGF2_dB_dTFEphys_K = -0.121000 dTn1_dTFEphys_K =      0.246000 dTn2_dTFEphys_K =      0.246000  There are      4 time windows tmin tmax   25.00   211.00   346.00  1203.00   1318.00 1732.00   1913.00 2707.00  Sky Sensor = SKY_TEMP Ref Sensor = REF_TEMP FEM Sensor = FEM_TEMP  SKY_TEMPREF_TEMP FEM_TEMP </pre>	<pre> FEM susceptibility INPUT Frequency (GHz) =      44 Receiver: LFI Channel : D Load correct : Yes r =      1.1176707 Model: FM Gain calibration factor (V/K) = value of RaNA_View LfeedOMT_dB =      0.100000 L4K_dB =      0.100000 GF1_dB =      35 GF2_dB =      35 TnF1_K =      20 TnF2_K =      20 dGF1_dB_dTFEphys_K = -0.130000 dGF2_dB_dTFEphys_K = -0.130000 dTn1_dTFEphys_K =      0.145000 dTn2_dTFEphys_K =      0.145000  There are      4 time windows tmin tmax   25.00   211.00   346.00  1203.00   1318.00 1732.00   1913.00 2707.00  Sky Sensor = SKY_TEMP Ref Sensor = REF_TEMP FEM Sensor = FEM_TEMP  SKY_TEMPREF_TEMP FEM_TEMP </pre>



12.90548801	7.99992561	20.50028610	12.90548801	7.99992561	20.50028610
12.90922451	7.99997711	22.00064087	12.90922451	7.99997711	22.00064087
12.91474056	7.99996519	24.00156212	12.91474056	7.99996519	24.00156212
12.92889786	7.99997425	27.00092316	12.92889786	7.99997425	27.00092316
Radiometer outputs (K)			Radiometer outputs (K)		
Tsky Tref			Tsky Tref		
34.220738	30.223612		36.527650	32.681942	
34.350506	30.421420		36.658009	32.879958	
34.523009	30.689473		36.835192	33.153305	
34.779168	31.106957		37.150232	33.624005	
Tsky-r*Tref			Tsky-r*Tref		
-0.094200633			-0.090956591		
-0.22520089			-0.21928645		
-0.44173944			-0.43033382		
OUTPUT			OUTPUT		
ftheo (K/K) fmeas (K/K)			ftheo (K/K) fmeas (K/K)		
-0.069630	-0.069716		-0.068124	-0.068068	

### 7.3.2 Analysis using the SMON\_TMP probe as sky load temperature:

The default parameters for the four channels are:

*Table -6: Default input parameters for RCA\_THF analysis*

	Ch. A	Ch. B	Ch. C	Ch. D
<b>Freq. (GHz)</b>	30			
<b>L<sub>feed-OMT</sub> (dB)</b>	0.1			
<b>L<sub>4k</sub> (dB)</b>	0.1			
<b>r</b>	1.0830277	1.0594471	1.1322518	1.1176707
<b>T<sub>sky</sub> (K)</b>	13.227			
<b>T<sub>ref</sub> (K)</b>	7.9999			
<b>G<sub>F1</sub><sup>dB</sup> (dB)</b>	35			
<b>G<sub>F2</sub><sup>dB</sup> (dB)</b>	35			
<b>T<sub>nF1</sub> (K)</b>	20	20	20	20
<b>T<sub>nF2</sub> (K)</b>	20	20	20	20
<b>∂G<sub>F1</sub><sup>dB</sup>/∂T<sub>phys</sub><sup>FE</sup> (dB/K)</b>	-0.05	-0.05	-0.05	-0.05
<b>∂G<sub>F2</sub><sup>dB</sup>/∂T<sub>phys</sub><sup>FE</sup> (dB/K)</b>	-0.05	-0.05	-0.05	-0.05
<b>∂T<sub>nF1</sub>/∂T<sub>phys</sub><sup>FE</sup> (K/K)</b>	0.08	0.08	0.08	0.08
<b>∂T<sub>nF2</sub>/∂T<sub>phys</sub><sup>FE</sup> (K/K)</b>	0.08	0.08	0.08	0.08
<b>Gain Calibration Factor (V/K)</b>	0.0035	0.0039	0.005	0.00486

Calculating the theoretical and the measured transfer functions with RaNA, we obtain:

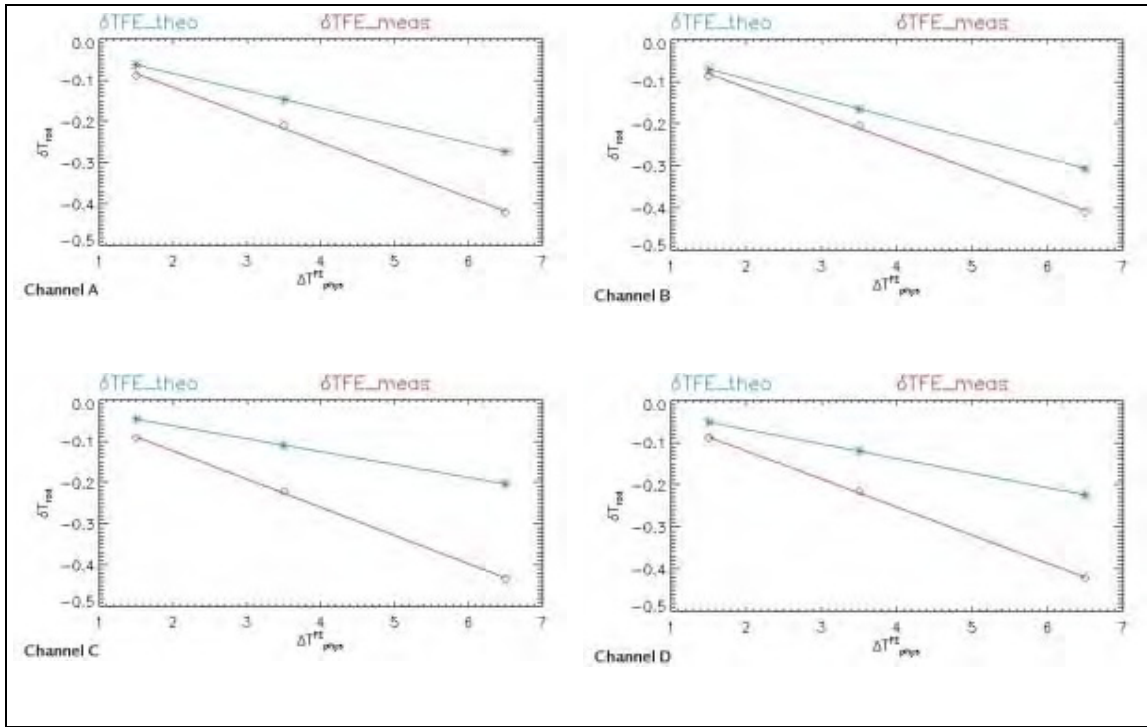


Figure -14: RCA\_THF theoretical (blue) Vs measured (red) transfer function

Table -7: RCA\_THF Analysis Result based on default parameters

	Channel A	Channel B	Channel C	Channel D
$f_{\text{therm}}^{\text{front-end}}$ (K/K) theoretical	-0.041998	-0.04710	-0.03134	-0.0345
$f_{\text{therm}}^{\text{front-end}}$ (K/K) measured	-0.066585	-0.06473	-0.06831	-0.06667

The complete RaNA output:

<pre> FEM susceptibility INPUT Frequency (GHz) = 44 Receiver: LFI Channel : A Load correct : Yes r = 1.0830277 Model: FM Gain calibration factor (V/K) = value of RaNA_View LfeedOMT_dB = 0.100000 L4K_dB = 0.100000 GF1_dB = 35 GF2_dB = 35 TnF1_K = 20 TnF2_K = 20 dGF1_dB_dTFEphys_K = -0.0500000 dGF2_dB_dTFEphys_K = -0.0500000 dTn1_dTFEphys_K = 0.0800000 dTn2_dTFEphys_K = 0.0800000  There are 4 time windows tmin tmax 25.00 211.00 346.00 1203.00 1318.00 1732.00 1913.00 2707.00           </pre>	<pre> FEM susceptibility INPUT Frequency (GHz) = 44 Receiver: LFI Channel : B Load correct : Yes r = 1.0594471 Model: FM Gain calibration factor (V/K) = value of RaNA_View LfeedOMT_dB = 0.100000 L4K_dB = 0.100000 GF1_dB = 35 GF2_dB = 35 TnF1_K = 20 TnF2_K = 20 dGF1_dB_dTFEphys_K = -0.0500000 dGF2_dB_dTFEphys_K = -0.0500000 dTn1_dTFEphys_K = 0.0800000 dTn2_dTFEphys_K = 0.0800000  There are 4 time windows tmin tmax 25.00 211.00 346.00 1203.00 1318.00 1732.00 1913.00 2707.00           </pre>
---	---



<p>Sky Sensor = SMON_TMP Ref Sensor = REF_TEMP FEM Sensor = FEM_TEMP</p> <p>SMON_TMPREF_TEMP FEM_TEMP 13.22702599 7.99992561 20.50028610 13.22896767 7.99997711 22.00064087 13.23277760 7.99996519 24.00156212 13.24173832 7.99997425 27.00092316</p> <p>Radiometer outputs (K) Tsky Tref 37.503393 34.628286 37.637063 34.833788 37.816691 35.111307 38.085712 35.554044</p> <p>Tsky-r*Tref -0.088893927 -0.20982718 -0.42030175</p> <p>OUTPUT ftheo (K/K) fmeas (K/K) -0.041998 -0.066585</p>	<p>Sky Sensor = SMON_TMP Ref Sensor = REF_TEMP FEM Sensor = FEM_TEMP</p> <p>SMON_TMPREF_TEMP FEM_TEMP 13.22702599 7.99992561 20.50028610 13.22896767 7.99997711 22.00064087 13.23277760 7.99996519 24.00156212 13.24173832 7.99997425 27.00092316</p> <p>Radiometer outputs (K) Tsky Tref 38.135236 35.995413 38.261707 36.196441 38.422706 36.459620 38.662420 36.878813</p> <p>Tsky-r*Tref -0.086506326 -0.20433284 -0.40873088</p> <p>OUTPUT ftheo (K/K) fmeas (K/K) -0.047102 -0.064733</p>
<p>FEM susceptibility INPUT Frequency (GHz) = 44 Receiver: LFI Channel : C Load correct : Yes r = 1.1322518 Model: FM Gain calibration factor (V/K) = value of RaNA_View LfeedOMT_dB = 0.100000 L4K_dB = 0.100000 GF1_dB = 35 GF2_dB = 35 TnF1_K = 20 TnF2_K = 20 dGF1_dB_dTFEphys_K = -0.0500000 dGF2_dB_dTFEphys_K = -0.0500000 dTn1_dTFEphys_K = 0.0800000 dTn2_dTFEphys_K = 0.0800000</p> <p>There are 4 time windows tmin tmax 25.00 211.00 346.00 1203.00 1318.00 1732.00 1913.00 2707.00</p> <p>Sky Sensor = SMON_TMP Ref Sensor = REF_TEMP FEM Sensor = FEM_TEMP</p> <p>SMON_TMPREF_TEMP FEM_TEMP 13.22702599 7.99992561 20.50028610 13.22896767 7.99997711 22.00064087 13.23277760 7.99996519 24.00156212 13.24173832 7.99997425 27.00092316</p> <p>Radiometer outputs (K) Tsky Tref 34.220738 30.223612 34.352301 30.421420 34.526510 30.689473 34.787865 31.106957</p> <p>Tsky-r*Tref -0.092405818 -0.22169996 -0.43304193</p> <p>OUTPUT ftheo (K/K) fmeas (K/K) -0.031344 -0.068308</p>	<p>FEM susceptibility INPUT Frequency (GHz) = 44 Receiver: LFI Channel : D Load correct : Yes r = 1.1176707 Model: FM Gain calibration factor (V/K) = value of RaNA_View LfeedOMT_dB = 0.100000 L4K_dB = 0.100000 GF1_dB = 35 GF2_dB = 35 TnF1_K = 20 TnF2_K = 20 dGF1_dB_dTFEphys_K = -0.0500000 dGF2_dB_dTFEphys_K = -0.0500000 dTn1_dTFEphys_K = 0.0800000 dTn2_dTFEphys_K = 0.0800000</p> <p>There are 4 time windows tmin tmax 25.00 211.00 346.00 1203.00 1318.00 1732.00 1913.00 2707.00</p> <p>Sky Sensor = SMON_TMP Ref Sensor = REF_TEMP FEM Sensor = FEM_TEMP</p> <p>SMON_TMPREF_TEMP FEM_TEMP 13.22702599 7.99992561 20.50028610 13.22896767 7.99997711 22.00064087 13.23277760 7.99996519 24.00156212 13.24173832 7.99997425 27.00092316</p> <p>Radiometer outputs (K) Tsky Tref 36.527650 32.681942 36.659804 32.879958 36.838693 33.153305 37.158929 33.624005</p> <p>Tsky-r*Tref -0.089161776 -0.21578551 -0.42163631</p> <p>OUTPUT ftheo (K/K) fmeas (K/K) -0.034500 -0.066660</p>

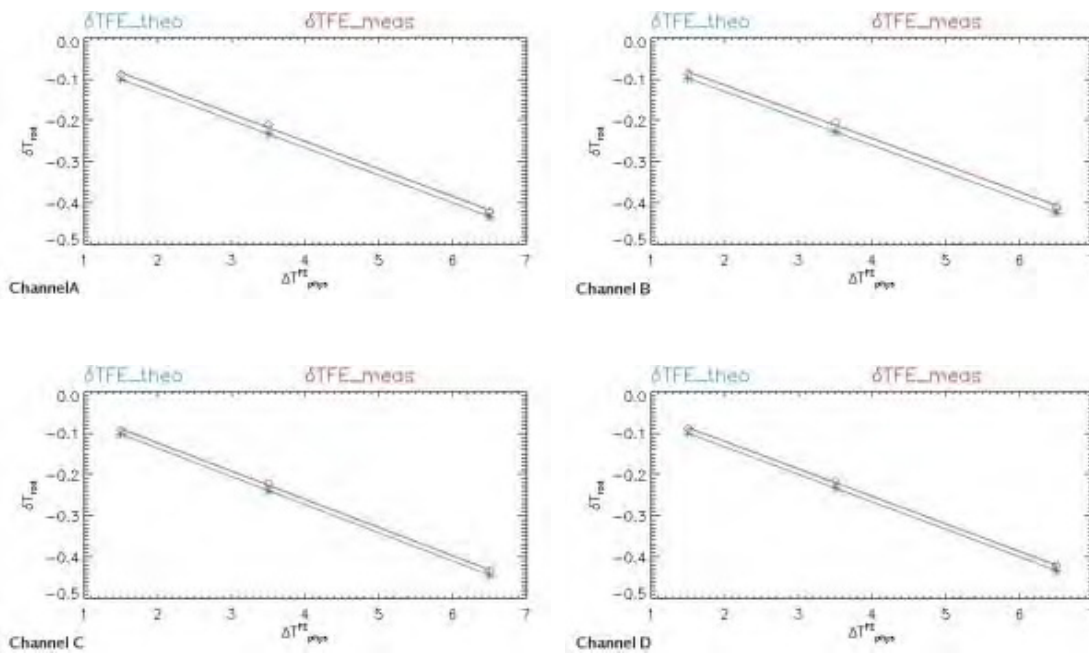


To improve the results obtained with the default parameters, I am going to change any of them. In particular, I change the  $\partial G_{FE}^{dB} / \partial T_{phys}^{FE}$  and  $\partial T_{nFE} / \partial T_{phys}^{FE}$ . The best values will be:

**Table -8: Optimized parameters of RCA\_THF test**

	Ch. A	Ch. B	Ch. C	Ch. D
$\partial G_{F1}^{dB} / \partial T_{phys}^{FE}$ (dB/K)	-0.085	-0.073	-0.09	-0.11
$\partial G_{F2}^{dB} / \partial T_{phys}^{FE}$ (dB/K)	-0.085	-0.073	-0.09	-0.11
$\partial T_{nF1} / \partial T_{phys}^{FE}$ (K/K)	0.095	0.067	0.25	0.126
$\partial T_{nF2} / \partial T_{phys}^{FE}$ (K/K)	0.095	0.067	0.25	0.126

and calculating the transfer functions, the new results:



**Figure -15: RCA\_THF theoretical Vs measured transfer function after optimization of the parameters.**

**Table -9: RCA\_THF Optimal transfer function Vs. theoretical**

	Channel A	Channel B	Channel C	Channel D
$f_{therm}^{front-end}$ (K/K) theoretical	-0.066559	-0.065102	0.0683	-0.06659
$f_{therm}^{front-end}$ (K/K) measured	-0.066585	-0.064733	-0.068308	-0.06666

The complete RaNA output:

FEM susceptibility INPUT Frequency (GHz) = 44	FEM susceptibility INPUT Frequency (GHz) = 44
---	---



<pre> Receiver: LFI Channel : A Load correct : Yes r = 1.0830277 Model: FM Gain calibration factor (V/K) = value of RaNA_View LfeedOMT_dB = 0.100000 L4K_dB = 0.100000 GF1_dB = 35 GF2_dB = 35 TnF1_K = 20 TnF2_K = 20 dGF1_dB_dTFEphys_K = -0.0850000 dGF2_dB_dTFEphys_K = -0.0850000 dTn1_dTFEphys_K = 0.0950000 dTn2_dTFEphys_K = 0.0950000  There are 4 time windows tmin tmax 25.00 211.00 346.00 1203.00 1318.00 1732.00 1913.00 2707.00  Sky Sensor = SMON_TMP Ref Sensor = REF_TEMP FEM Sensor = FEM_TEMP  SMON_TMPREF_TEMPFEM_TEMP 13.22702599 7.99992561 20.50028610 13.22896767 7.99997711 22.00064087 13.23277760 7.99996519 24.00156212 13.24173832 7.99997425 27.00092316  Radiometer outputs (K) Tsky Tref 37.503393 34.628286 37.637063 34.833788 37.816691 35.111307 38.085712 35.554044  Tsky-r*Tref -0.088893927 -0.20982718 -0.42030175  OUTPUT ftheo (K/K) fmeas (K/K) -0.066559 -0.066585 </pre>	<pre> Receiver: LFI Channel : B Load correct : Yes r = 1.0594471 Model: FM Gain calibration factor (V/K) = value of RaNA_View LfeedOMT_dB = 0.100000 L4K_dB = 0.100000 GF1_dB = 35 GF2_dB = 35 TnF1_K = 20 TnF2_K = 20 dGF1_dB_dTFEphys_K = -0.0730000 dGF2_dB_dTFEphys_K = -0.0730000 dTn1_dTFEphys_K = 0.0670000 dTn2_dTFEphys_K = 0.0670000  There are 4 time windows tmin tmax 25.00 211.00 346.00 1203.00 1318.00 1732.00 1913.00 2707.00  Sky Sensor = SMON_TMP Ref Sensor = REF_TEMP FEM Sensor = FEM_TEMP  SMON_TMPREF_TEMPFEM_TEMP 13.22702599 7.99992561 20.50028610 13.22896767 7.99997711 22.00064087 13.23277760 7.99996519 24.00156212 13.24173832 7.99997425 27.00092316  Radiometer outputs (K) Tsky Tref 38.135236 35.995413 38.261707 36.196441 38.422706 36.459620 38.662420 36.878813  Tsky-r*Tref -0.086506326 -0.20433284 -0.40873088  OUTPUT ftheo (K/K) fmeas (K/K) -0.065102 -0.064733 </pre>
<pre> FEM susceptibility INPUT Frequency (GHz) = 44 Receiver: LFI Channel : C Load correct : Yes r = 1.1322518 Model: FM Gain calibration factor (V/K) = value of RaNA_View LfeedOMT_dB = 0.100000 L4K_dB = 0.100000 GF1_dB = 35 GF2_dB = 35 TnF1_K = 20 TnF2_K = 20 dGF1_dB_dTFEphys_K = -0.0900000 dGF2_dB_dTFEphys_K = -0.0900000 dTn1_dTFEphys_K = 0.250000 dTn2_dTFEphys_K = 0.250000  There are 4 time windows tmin tmax 25.00 211.00 346.00 1203.00 1318.00 1732.00 1913.00 2707.00  Sky Sensor = SMON_TMP Ref Sensor = REF_TEMP FEM Sensor = FEM_TEMP  SMON_TMPREF_TEMPFEM_TEMP 13.22702599 7.99992561 20.50028610 13.22896767 7.99997711 22.00064087 13.23277760 7.99996519 24.00156212 13.24173832 7.99997425 27.00092316  Radiometer outputs (K) Tsky Tref 34.220738 30.223612 34.352301 30.421420 34.526510 30.689473 </pre>	<pre> FEM susceptibility INPUT Frequency (GHz) = 44 Receiver: LFI Channel : D Load correct : Yes r = 1.1176707 Model: FM Gain calibration factor (V/K) = value of RaNA_View LfeedOMT_dB = 0.100000 L4K_dB = 0.100000 GF1_dB = 35 GF2_dB = 35 TnF1_K = 20 TnF2_K = 20 dGF1_dB_dTFEphys_K = -0.1100000 dGF2_dB_dTFEphys_K = -0.1100000 dTn1_dTFEphys_K = 0.1260000 dTn2_dTFEphys_K = 0.1260000  There are 4 time windows tmin tmax 25.00 211.00 346.00 1203.00 1318.00 1732.00 1913.00 2707.00  Sky Sensor = SMON_TMP Ref Sensor = REF_TEMP FEM Sensor = FEM_TEMP  SMON_TMPREF_TEMPFEM_TEMP 13.22702599 7.99992561 20.50028610 13.22896767 7.99997711 22.00064087 13.23277760 7.99996519 24.00156212 13.24173832 7.99997425 27.00092316  Radiometer outputs (K) Tsky Tref 36.527650 32.681942 36.659804 32.879958 36.838693 33.153305 </pre>



34.787865	31.106957	37.158929	33.624005
Tsky-r*Tref		Tsky-r*Tref	
-0.092405818		-0.089161776	
-0.22169996		-0.21578551	
-0.43304193		-0.42163631	
OUTPUT		OUTPUT	
ftheo (K/K) fmeas (K/K)		ftheo (K/K) fmeas (K/K)	
-0.068300 -0.068308		-0.066590 -0.066660	

## 7.4 RCA\_ELE: SUSCEPTIBILITY TO DISTURBANCE ON BIAS LINES

The file considered is 044LFI26\_RCA\_FM\_ELE\_200605021037

Module used: Rana\_FFT, fast and normal FFT, no windowing

Binning: 5 ( $v < 100$  Hz), 1 above

Disturbance applied on Vg1 channel S1

Temperatures: Sky: 13 K, Ref: 8.5 K

I\_drain: stable on alla channels

By observing the FFT on selected data, a signal is present on SKY and LOAD data at the perturbing frequency. Amplitude is of the order of  $10E-4$  V/Sqr(Hz). Perturbing signal is not present in S-L data.

50 Hz signal is observed in SKY , LOAD and unscrambled data. It is not observed, as expected, in S-L data.

Spikes are present on LOAD data only around 30Hz. These effect, as for the other RCAs, is due to the data acquisition of housekeeping data. This effect is not observed when 2kHz disturbance is applied on C and D channels.

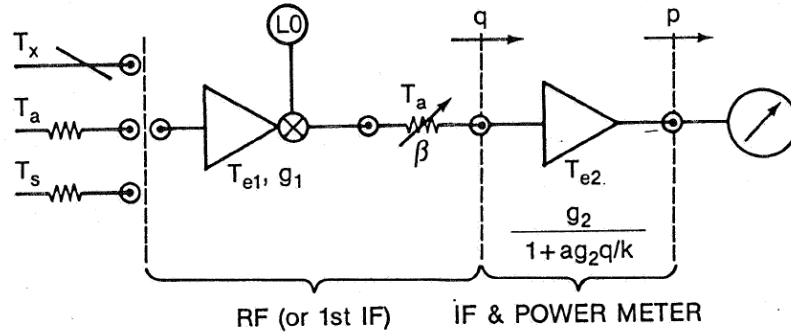
Spikes (amplitude of the order of  $10e-4$  V/Sqr(Hz)) are also observed at high frequency in unscrambled data for  $v_{dist} < 4$ kHz. Peaks are centered at a frequency of  $4096 - v_{dist}$ . When  $v_{dist}$  is above 4kHz, no ‘direct’ disturbance is observed in SKY and LOAD data. Still, peaks at frequency  $4096 - v_{dist}$ . are observed. These spikes do not disappear in SKY – LOAD data. This effect is still to be studied in detail.

## 8 CONCLUSIONS and CALIBRATION MATRIX

## 9 GAIN MODEL

A new gain model has been developed based on paper of “William C. Daywitt, *Radiometer Equation and Analysis of Systematic Errors for the NIST Automated Radiometers*, 1989 ” modified for the case of LFI.

The gain model is the following:



Basically the hypothesis are the following:  
 The FEM has constant gain and Tnoise.

$$FEM : \begin{cases} Gain = G^{(FEM)} \\ Noise = T_N^{(FEM)} \end{cases}$$

The BEM has a gain which depends on the BEM input power as follows

$$BEM : \begin{cases} Gain = G^{BEM} = \frac{G_0^{BEM}}{1 + b \cdot G_0^{BEM} \cdot p} \\ Noise = T_N^{BEM} \end{cases}$$

Where  $p$  is the power entering the BEM and  $a$  is a parameter defining the non linearity of the BEM. Of course this is a particular gain model but some consideration can be appointed:

- 1) For  $b = 0$  the radiometer is linear.
- 2) For  $b = \text{infinity}$  the BEM has a  $G = 0$
- 3) For  $p = \text{infinity}$  the BEM is completely compressed and  $G = 0$  has expected

Now the power entering the BEM (we neglect the attenuation of the WGs which may be included in the FEM parameters) is:

$$p = k \cdot B \cdot G_0^{FEM} \cdot (T_A + T_N^*), \text{ Where } T_N^* = T_N^{BEM} + \frac{T_N^*}{G_0^{FEM}}$$

So at the output of the BEM we have (the diode constant is considered inside the BEM gain)

$$V_{out} = k \cdot B \cdot G_0^{FEM} \cdot \frac{G_0^{BEM} \cdot (T_A + T_N^*)}{1 + b \cdot k \cdot B \cdot G_0^{BEM} \cdot (T_A + T_N^*)} = G_0 \cdot \left[ \frac{1}{1 + b \cdot G_0 \cdot (T_A + T_N^*)} \right] \cdot (T_A + T_N^*)$$

$$G_0 = G_0^{FEM} \cdot G_0^{BEM} \cdot k \cdot B$$

Or in a compact way

$$V_{out} = G_{tot} \cdot (T_A + T_N^*)$$

$$G_{tot} = G_0 \cdot \left[ \frac{1}{1 + b \cdot G_0 \cdot (T_A + T_N^*)} \right]$$



$G_{tot}$  is the radiometer gain which depends on the input antenna temperature.

A fit on the data has been performed with this following function:

$$V_{out} = G_0 \cdot \left[ \frac{1}{1 + b \cdot G_0 \cdot (T_A + T_N^*)} \right] \cdot (T_A + T_N^*)$$

And  $G_0$ ,  $T_N^*$  and  $b$  have been derived from data taken on sky temperature steps.

Here the results:

	$G_0$	$T_N^*$	$b$
Detector A	0.00523	18.1	1.11376
Detector B	0.00674	17.2	1.42726
Detector C	0.00755	16.6	0.9632
Detector D	0.00828	16.3	1.2297

The gain functions have been derived and the white noise levels have been calculated:

$$G_{tot}^A = \left[ \frac{0.00532}{1 + 0.0058249648 \cdot (T_A + 18.1)} \right]$$

$$G_{tot}^B = \left[ \frac{0.00674}{1 + 0.0096197324 \cdot (T_A + 17.2)} \right]$$

$$G_{tot}^C = \left[ \frac{0.00755}{1 + 0.0072721600 \cdot (T_A + 16.6)} \right]$$

$$G_{tot}^D = \left[ \frac{0.00828}{1 + 0.0101819160 \cdot (T_A + 16.3)} \right]$$

```
[17/05/2006 15:23 "/ChA" (2453872)]
Data: Data1_B
Model: Villa
```

```
Chi^2    R^2
-----
8.9024E-8 0.9999
-----
```

Parameter	Value	Error
G	0.00523	0.00034
T0	18.1037	1.29112
b	1.11376	0.15519

```
[17/05/2006 15:25 "/ChB" (2453872)]
Data: Data1_C
Model: Villa
```

```
Chi^2    R^2
-----
1.129E-7 0.99988
-----
```



Parameter	Value	Error
G	0.00674	0.00047
T0	17.24716	1.34017
b	1.42726	0.13155

[17/05/2006 15:27 "/ChC" (2453872)]  
Data: Datal\_D  
Model: Villa

Chi <sup>2</sup>	R <sup>2</sup>
1.8724E-7	0.99989

Parameter	Value	Error
G	0.00755	0.00051
T0	16.59703	1.29069
b	0.9632	0.1165

[17/05/2006 15:28 "/ChD" (2453872)]  
Data: Datal\_E  
Model: Villa

Chi <sup>2</sup>	R <sup>2</sup>
1.2334E-7	0.99991

Parameter	Value	Error
G	0.00828	0.00049
T0	16.32751	1.10625
b	1.2297	0.09297