

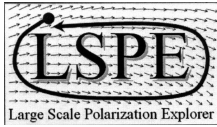

Publication Year	2016
Acceptance in OA	2024-03-05T16:12:00Z
Title	LSPE – STRIP Cryostat mass and CoG estimation
Authors	MORGANTE, GIANLUCA, VILLA, Fabrizio
Handle	http://hdl.handle.net/20.500.12386/34893
Volume	LSPE-STRIP-TN-002



IASF-BO

Document No.: LSPE-STRIP-
Issue/Rev. No.: TN-002 1.0
Date: December 2016
Page: 1/7

TITLE: LSPE – STRIP Cryostat mass and CoG estimation

PROJECT REF.: LSPE-STRIP-TN-002 PAGE: 1 of 7

ISSUE/REV.: 1.0 DATE: December 2016

Prepared by G. Morgante, F. Villa	Date: 19 December 2016
Agreed by	Date:
Released by	Date:

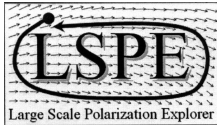

Table of contents

Mass estimation	2
Center of gravity	3

Mass estimation

The cryostat vacuum shell is made of Aluminum alloy (TBD) with an average thickness of 10 mm. This is a conservative value as the stiffening rings designed should allow to reduce the thickness up to a factor of 2. This value will be relaxed, if possible, after the mechanical analysis of the cryostat made by the provider.

A conservative evaluation of the whole STRIP cryostat assembly (including the cryostat, its external supports, the cold head, the electronics etc.), based on up-to-date assumptions, is reported in the following table:

Aluminum alloy case				
Item	Material	n	M _{unit} [kg]	M _{tot} [kg]
Vacuum shell body	Al alloy	1	70.1	70.1
VShell Top Flange	Al alloy	1	8.3	8.3
VShell Bottom Flange	Al alloy	1	20.1	20.1
Window holder	Al alloy	1	3.6	3.6
100K Shield body	Cu	1	20.2	20.2
100K shield top flange	Cu	1	6.6	6.6
100K shield bottom flange	Cu	1	16.7	16.7
Filter holder	Cu	1	2.5	2.5
FPU supporting structure	G10	1	4	4

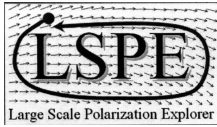

Window	UHMWP	1	16.7	16.7
Filter	TBD	1	0.9	0.9
Cold head	SS/Cu	1	20.7	20.7
FPU	Al + Cu	1	64	64
Vacuum flanges/valves/Feed thru's	Al/SS	8	2.5	20
Vacuum sensor	SS	1	0.5	0.5
Harness	Manganine/Cu	5	1.2	6
MLI	Mylar/Al	4	1	4
Struts to mount	SS/AL	2	15	30
T_Control Flange	Cu	1	5.6	5.6
Thermal Straps	Cu	20	0.5	10
Electronics Boxes	Al/other	4	5	20
Compressed air piping	SS	1	1	1
Weather protection	Al	1	1.5	1.5
		Total		353
		Total w/margin		423.6

A 20% margin has been applied to the total mass resulting in the table. As some light-weighting is expected to be carried out on the final design at the time of fabrication, the STRIP cryostat mass can be assumed to be:

Center of gravity

In the present configuration (see Figures below) the center of gravity of the cryostat can be assumed to fall in a region of space defined by a sphere with a radius of 75 mm around the point:

$$X_{\text{CoG}} = - 35 \text{ mm} ; Y_{\text{CoG}} = + 35 \text{ mm} ; Z_{\text{CoG}} = - 242.5 \text{ mm}$$

with the origin of the coordinates reference frame corresponding to the telescope focal point, Z being the optical axis and the gravity vector acting in the XY plane at various angles around the Z axis (cold head oriented with tip downward).

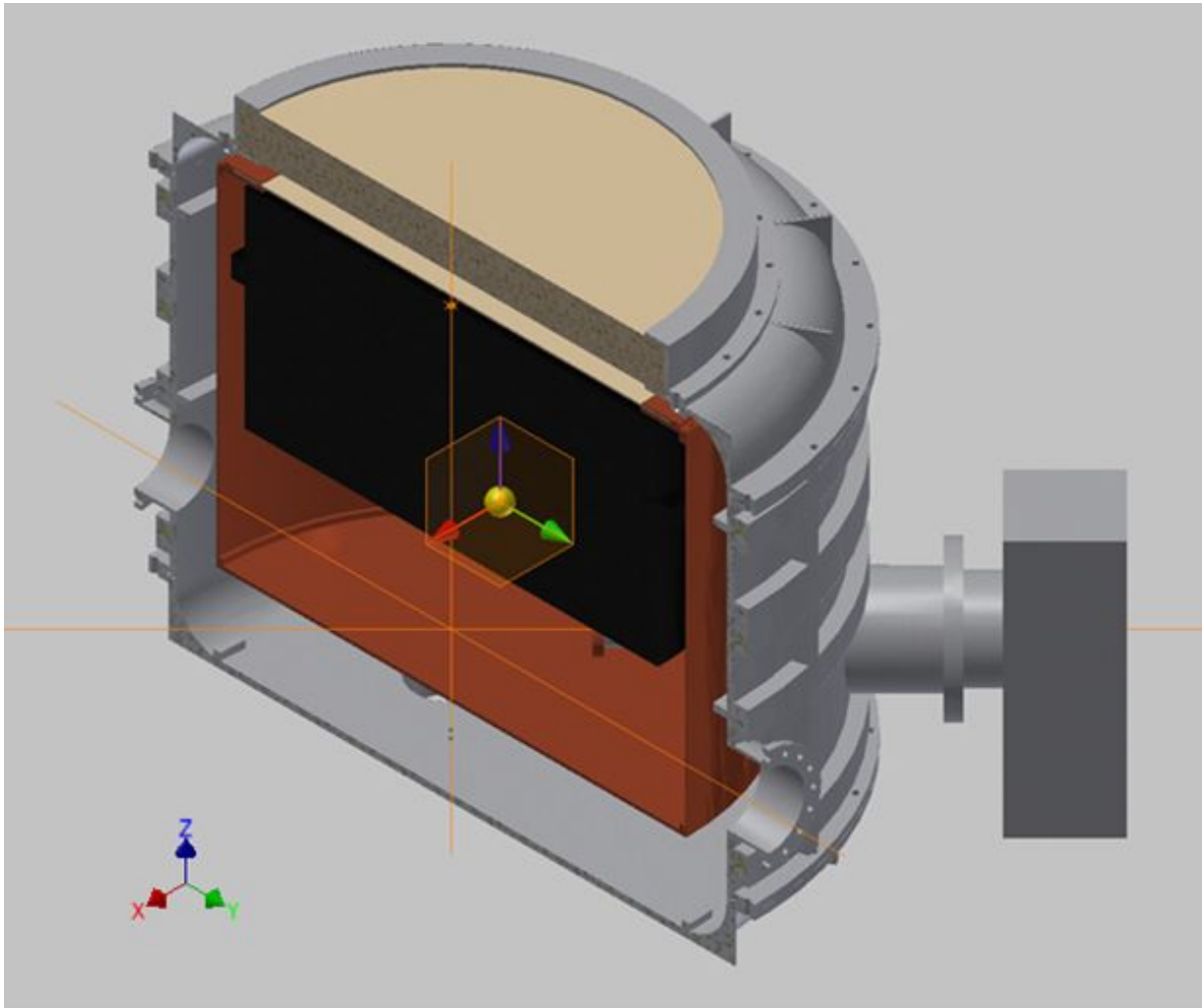

Figure 1. CAD view of the STRIP cryostat CoG

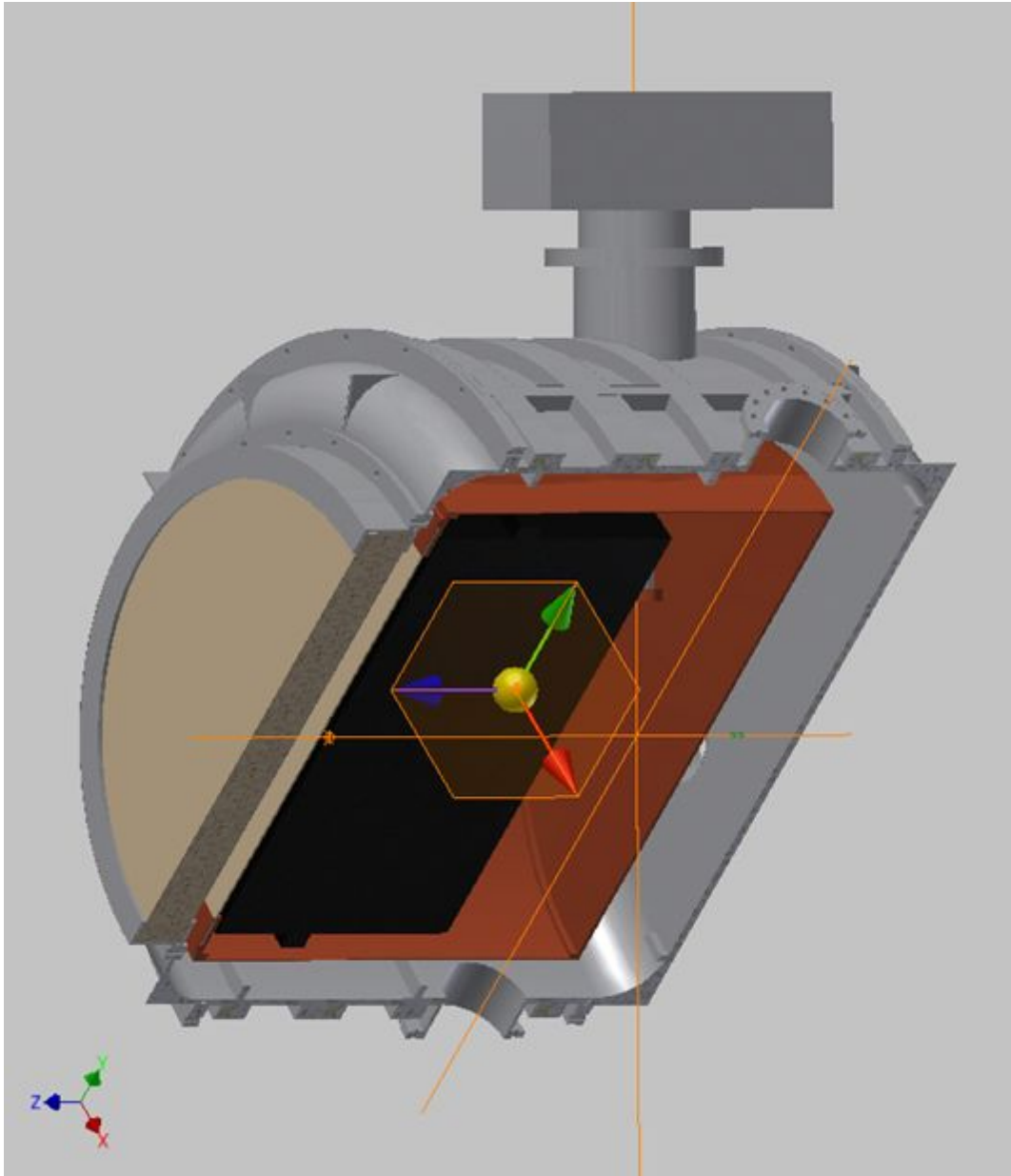

Figure 2. STRIP cryostat CoG with gravity along the vertical direction (Front view)

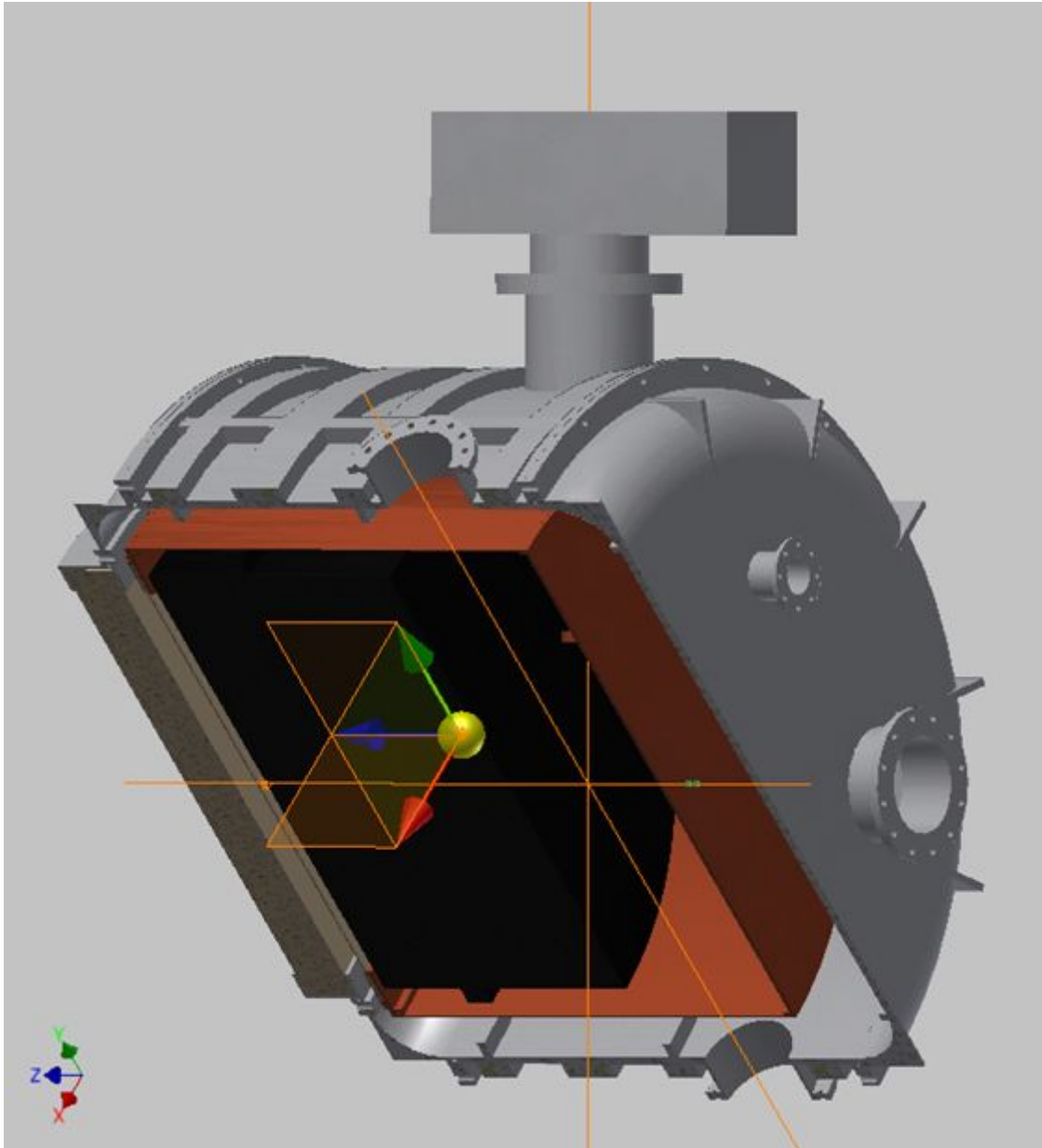

Figure 3. STRIP cryostat CoG with gravity along the vertical direction (Rear view)

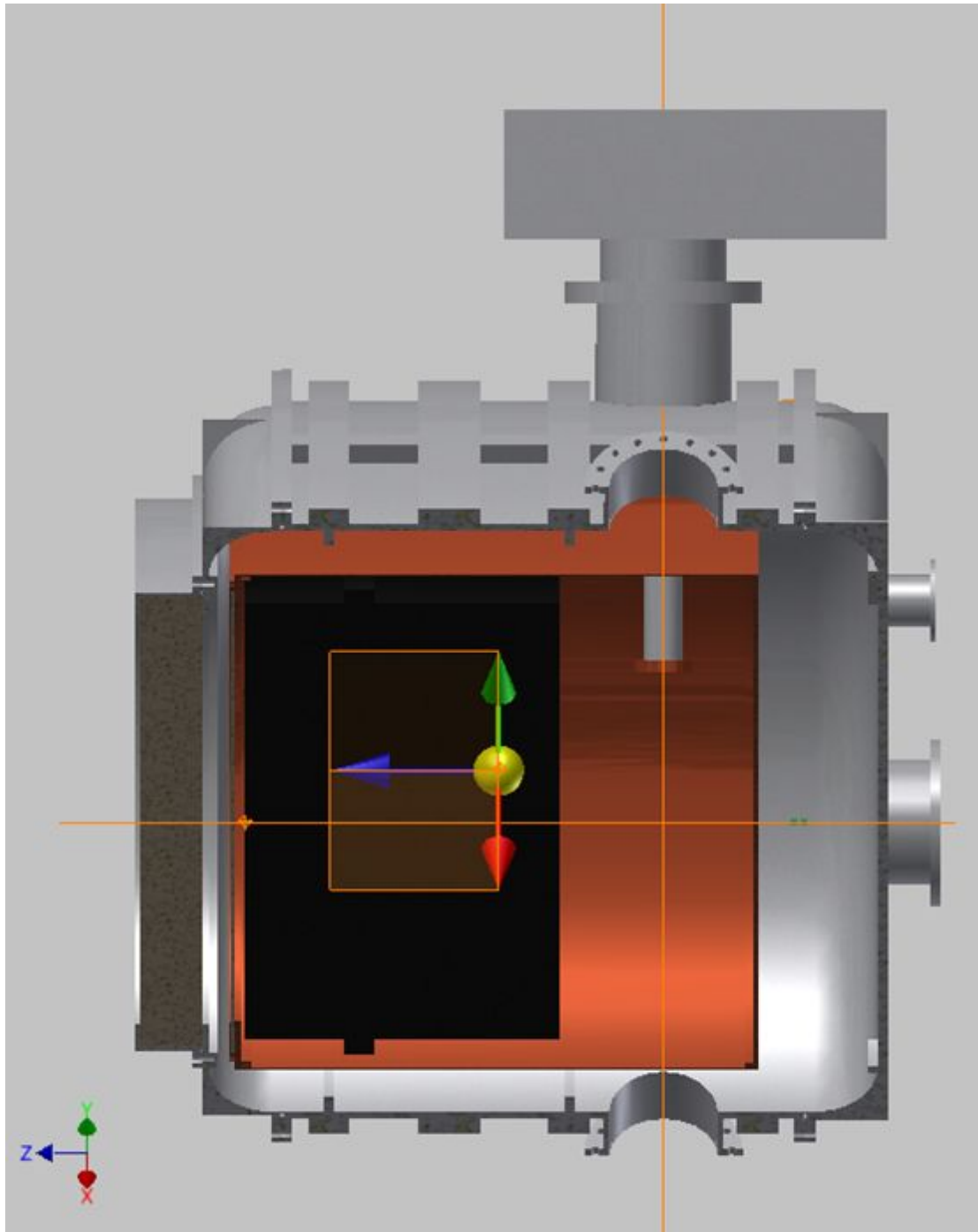

Figure 4. STRIP cryostat CoG with gravity along the vertical direction (Side view)