



Publication Year	2015
Acceptance in OA	2020-06-01T15:15:58Z
Title	EAS array of the NEVOD Experimental Complex
Authors	Yashin, I. I., Amelchakov, M. B., Ampilogov, N. V., Barbashina, N. S., Bogdanov, A. G., Chiavassa, A., Fomenko, S. V., Kamlev, N. N., Khokhlov, S. S., Kindin, V. V., Kokoulin, R. P., Kompaniets, K. G., Kutovoy, V. Yu, Likiy, O. I., Mannocchi, G., Ovchinnikov, V. V., Petrukhin, A. A., Saavedra, O., TRINCHERO, GIAN CARLO, Shestakov, V. V., Shulzhenko, I. A., Shutenko, V. V.
Publisher's version (DOI)	10.1088/1742-6596/632/1/012029
Handle	http://hdl.handle.net/20.500.12386/25857
Journal	JOURNAL OF PHYSICS. CONFERENCE SERIES
Volume	632

PAPER • OPEN ACCESS

EAS array of the NEVOD Experimental Complex

To cite this article: I I Yashin *et al* 2015 *J. Phys.: Conf. Ser.* **632** 012029

View the [article online](#) for updates and enhancements.

Related content

- [Measuring module of the Cherenkov water detector NEVOD](#)
V V Kindin, M B Amelchakov, N S Barbashina *et al.*
- [Investigation of cascade showers in the Cherenkov water detector NEVOD](#)
S S Khokhlov, M B Amelchakov, N S Barbashina *et al.*
- [Cherenkov water detector NEVOD](#)
A A Petrukhin

Recent citations

- [Status of the Russian-Italian experiment NEVOD-EAS](#)
A Chiavassa *et al*
- [The array of scintillation detectors with natural boron for EAS neutrons investigations](#)
D.M. Gromushkin *et al*
- [Multisector scintillation detector with fiber-optic light collection](#)
N.V. Ampilogov *et al*



IOP | ebooks™

Bringing together innovative digital publishing with leading authors from the global scientific community.

Start exploring the collection—download the first chapter of every title for free.

EAS array of the NEVOD Experimental Complex

I I Yashin¹, M B Amelchakov¹, N V Ampilogov¹, N S Barbashina¹,
A G Bogdanov¹, A Chiavassa^{2,3}, S V Fomenko¹, N N Kamlev¹, S S Khokhlov¹,
V V Kindin¹, R P Kokoulin¹, K G Kompaniets¹, V Yu Kutovoy¹, O I Likiy¹,
G Mannocchi⁴, V V Ovchinnikov¹, A A Petrukhin¹, O Saavedra², G Trincherio⁴,
V V Shestakov¹, I A Shulzhenko¹ and V V Shutenko¹

¹ National Research Nuclear University MEPhI (Moscow Engineering Physics Institute), 115409 Moscow, Russia

² Dipartimento di Fisica dell' Università degli Studi di Torino, 10125 Torino, Italy

³ Sezione di Torino dell' Istituto Nazionale di Fisica Nucleare – INFN, 10125 Torino, Italy

⁴ Istituto di Fisica dello Spazio Interplanetario – INAF, 10133 Torino, Italy

E-mail: IYashin@mephi.ru

Abstract. A new setup for registration of the electromagnetic component of the EAS at the “knee” region of the energy spectrum of primary cosmic rays (PCR) is now under construction on the basis of the experimental complex NEVOD-DECOR (Moscow, Russia). The EAS array detecting system has a cluster organization. Clusters are located in the MEPhI campus. The specific features of the array registering system that provides particle detection, data acquisition, cluster synchronization and events selection are discussed. The results of counter characteristics study are also presented.

1. Introduction

In 2002-2009, a method of EAS registration based on a new variable (local muon density spectra (LMDS) at large zenith angles) was developed [4] at the experimental complex NEVOD-DECOR [1-3] (Moscow). The obtained results analysis of has demonstrated some anomalous behavior of LMDS at energies of 10^{15} - 10^{18} eV. It had been noticed that the intensity of muon bundles at high primary particle energies exceeds their estimated amount, even for heavy PCR composition (iron nuclei). However, the primary energy estimation based on the analysis of local density spectra of muons registered at different zenith angles is of very low accuracy ($\sigma(\lg E_0) \sim 0.4$). This is due to the contribution of the EAS to events with a fixed local muon density. This EAS have different energies and are registered at various (random) distances from their axis.

The construction of the NEVOD-EAS setup around the NEVOD-DECOR complex will provide for registering and determining of characteristics of extensive air showers with energies of 10^{15} - 10^{17} eV using a traditional scintillation counter technique. The introduction of the new setup in the structure of the NEVOD-DECOR complex will enable to reduce the range of PCR energies in which the change in the muon component behavior occurs.



2. NEVOD-EAS shower array

The NEVOD-EAS setup for registration of extensive air showers is an array of scintillation counters placed on the roofs of laboratory buildings in the MEPhI campus. The measuring system of the setup is organized according to a cluster principle (figure 1). Each cluster includes 16 counters combined in 4 detector stations (DS) and is served by the Local Post (LP) of preliminary data acquisition. The cluster dimensions are $\sim 20 \times 20 \text{ m}^2$. The characteristic distances between the clusters are $\sim 50 \text{ m}$. Creation of the setup will be carried out in 3 stages: central part (5 clusters, area $\sim 10^4 \text{ m}^2$, 2014-2015), 1st step of the peripheral part (7 clusters, area $\sim 2 \times 10^4 \text{ m}^2$, 2016-2017), 2nd step of the peripheral part (area $\sim 2 \times 10^5 \text{ m}^2$, 2018-2020).

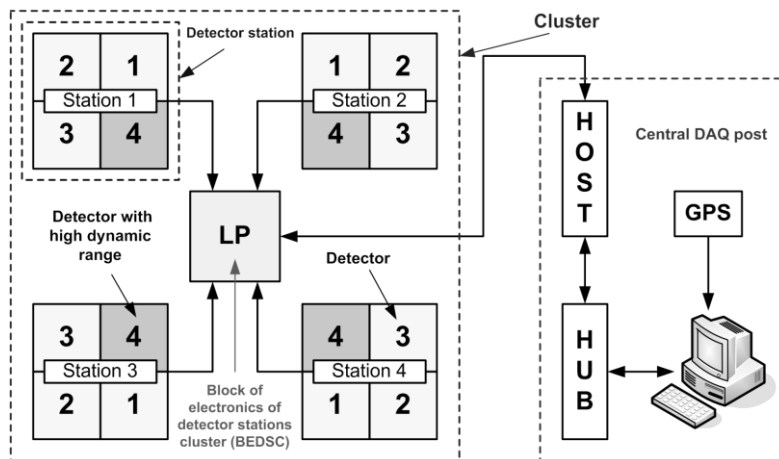

Figure 1. Structure of the NEVOD-EAS cluster.

2.1. Scintillation counter and detector station of the NEVOD-EAS shower array

Particles of the EAS electron-photon component are registered with scintillation counters [5] (figure 2a) which were previously used in the EAS-TOP [6] and KASCADE-Grande experiments [7]. The counter consists of the NE102A plastic scintillator with dimensions of $800 \times 40 \times 800 \text{ mm}^3$ and the Philips XP3462 PMT enclosed in a light-tight pyramidal housing made from stainless steel.

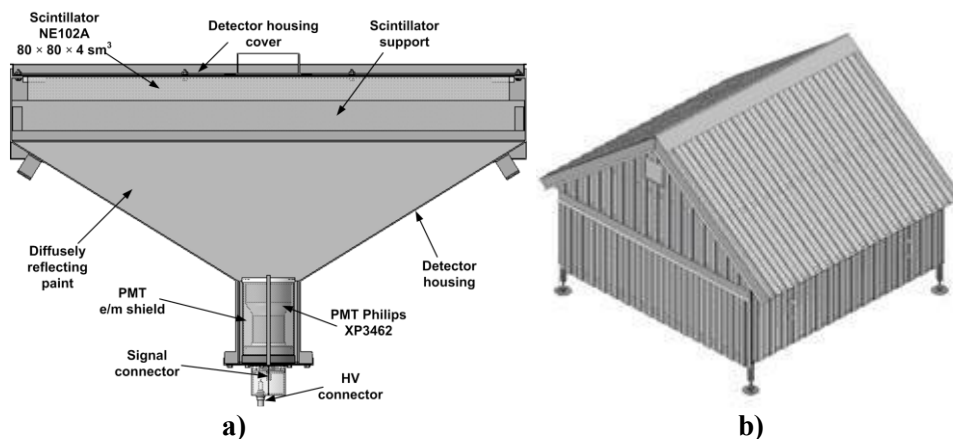

Figure 2. Counter (a) and detector station (b) of the NEVOD-EAS setup.

The inner surface of the counter housing is painted with a special diffuse-reflective coating to improve the collection of light from the flashes in the scintillator caused by the passage of particles through its sensitive volume. The scintillator is located at a distance of 30 cm above the PMT photocathode. The construction of the scintillation counter housing enables to install an additional Philips XP3462 PMT.

Detector stations are formed of 4 scintillation counters, three of them being equipped with only a “standard” photomultiplier, while the fourth one has both a “standard” and an “additional” PMT. Standard photomultipliers are selected and configured so that the most probable values of charge distributions of the responses of all four counters were almost the same. These photomultipliers are used to measure the particle density and arrival time of the detected EAS. The additional photomultiplier has a dynode system gain of approximately 90 times smaller than the standard PMT. This PMT provides a wide linearity range of the measured signals at high particle densities and allows to achieve a dynamic range of the DS ~ 10000 particles/m². Counters of the DS are enclosed in special housings that provide protection from moisture (figure 2b). Inside the DS housing, the DC/DC converter providing high voltage supply of the PMT and the temperature sensor measuring the DS temperature during the setup operation monitoring are installed.

2.2. Cluster of the NEVOD-EAS shower array

The NEVOD EAS cluster is formed of 4 DS placed in the vertices of a rectangle with characteristic dimensions of 20×20 m². Analog signals from the DS PMTs come via cables to the cluster LP. Local Post provides selection of events according to the intracluster trigger conditions, digitizes the amplitude information and transmits data to the Central DAQ Post via optical link. LP includes 2 boards of amplitude analysis (BAA), summator-multiplexer (SM), BAA controller (C), SM controller and power supply (+5 V and ± 12 V). Figure 3 shows the scheme of the cluster Local Post.

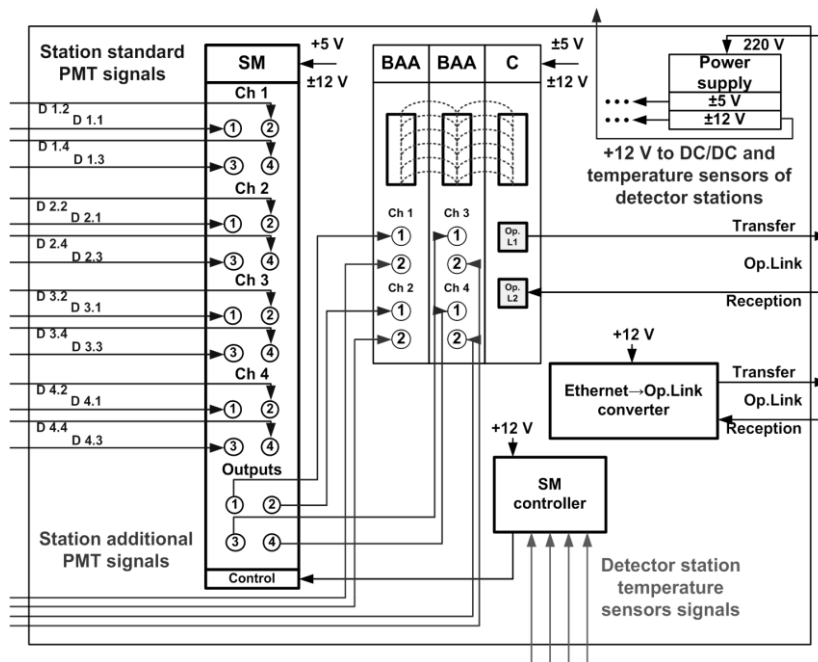

Figure 3. Scheme of the NEVOD-EAS Local Post.

BAA includes 2 channels with 2 inputs: active and passive. The signals on the inputs are digitized using 12-bit FADC with a sampling frequency of 0.2 GHz. For the active input, a 12-bit DAC is used to set the registration threshold.

The BAA controller selects events according to the specified triggering multiplicity of DS (from 1 to 4) within a time gate from 10 ns to 2 ms and transmits the data to the storage system. Each event is time-stamped with an accuracy up to 10 ns.

SM is intended for summing of analog signals from 4 standard PMTs of the DS and has 4 channels on 4 inputs. The summed signal from 4 standard PMTs of the DS is fed to the active input of the corresponding channel of BAA. The signal from the additional PMT is fed to the passive input. The SM also allows to turn on a defined input of each channel for registration of spectra from the selected

detector of the DS during the setup operation monitoring. Control of the SM is performed using the SM controller. SM controller also receives and transmits data from the DS temperature sensors.

2.3. Central DAQ post of the NEVOD-EAS shower array

The main functions of the Central Post of the data acquisition are: cluster synchronization; LP control; reception and storage of experimental and monitoring data. Central Post includes: server, GPS/GLONASS sensor, communication unit and module of LP control and synchronization.

The communication unit is intended for connection of server with clusters of the setup and includes hub and media converters (Ethernet→Opt.Link), which transmit control commands to the SM controllers of Local Posts and receive information about temperature inside the detector stations.

The module of LP control and synchronization consists of several units - Hosts. Each host has 4 optical channels for control and receiving of the experimental data from the LP. Each Host serves 4 LP. The Host has an Ethernet port for connection to the communication unit.

Time synchronization of clusters is performed using a GPS/GLONASS sensor connected to the server. The sensor generates a PPS signal with a frequency of 1 Hz. When receiving the PPS signal, the server sends a synchronization signal to the main Host of the group. The main Host synchronizes other Hosts using the clock generator. Hosts send synchronization pulses to the BAA controllers of the clusters that in their turn synchronize BAA. Thus, the NEVOD-EAS registering system operates in a synchronous mode. Synchronization accuracy of the cluster is 10 ns.

3. Characteristics of the NEVOD-EAS scintillation counter

At the preliminary stage of the NEVOD-EAS creation, the characteristics of photomultiplier tubes and scintillators have been studied.

3.1. Characteristics of the PMTs and scintillators

During the Philips XP3462 PMT testing the following characteristics have been studied: the high voltage which provides a gain of the photomultiplier dynode system $\sim 2 \times 10^6$; the spread of the PMT triggering delays (jitter) during its operation in the single photoelectron mode; the linearity range; the relative sensitivity (the response of the PMT to the photocathode illumination with a fixed intensity); the dependence of dark noise counting rate on the registration threshold.

At the initial stage of each PMT testing the value of high voltage providing the gain of the PMT $\sim 2 \times 10^6$ was determined using the technique of single photoelectron illumination of the PMT photocathode. The other characteristics were investigated at the high voltage defined at the initial stage. Figures 4-8 show distributions of 240 tested PMTs on the high voltage, single photoelectron jitter, upper limit of linearity range, relative (to the complete sample average) sensitivity of the photocathode and dark noise counting rate at the fixed threshold.

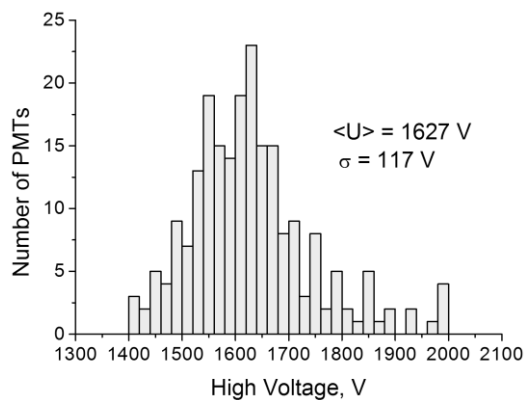

Figure 4. Distribution of the PMTs high voltage providing the PMT gain $\sim 2 \times 10^6$.

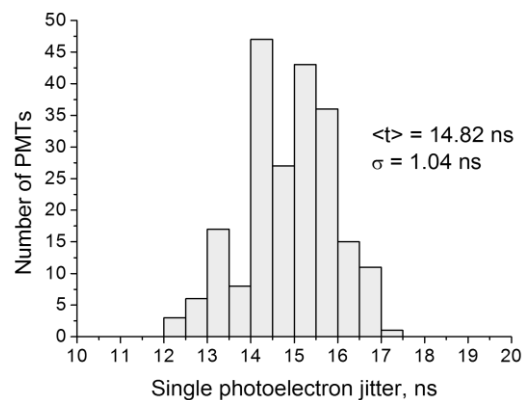

Figure 5. Distribution of the PMTs single photoelectron time jitter.

During the scintillator plate testing, the charge spectrum of counter response to the passage of near-vertical muon located by the muon telescope has been measured. The muon telescope consists of two scintillation counters with dimensions $10 \times 10 \text{ cm}^2$ placed in the central area of the studied scintillator. Figure 9 shows the distribution of the most probable values of the measured charge spectra for 192 scintillators divided by the complete sample average charge of the muon peak (distribution of the relative light yield of the scintillators).

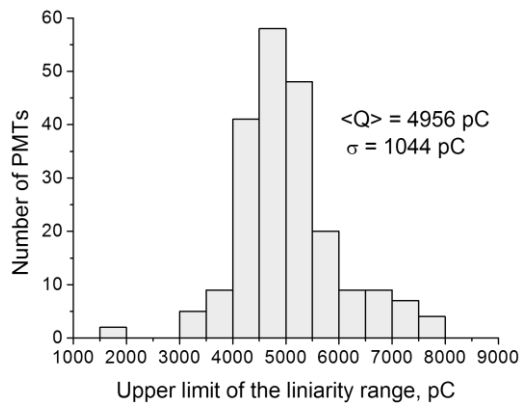

Figure 6. Distribution of the PMTs upper limit of linearity range.

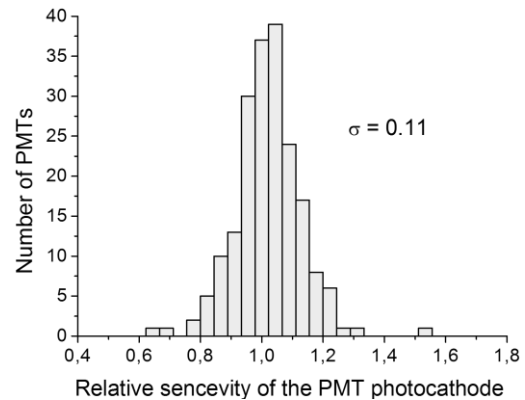

Figure 7. Distribution of the PMTs relative photocathode sensitivity.

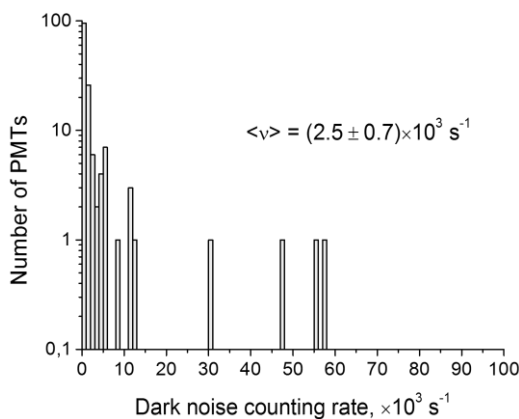

Figure 8. Distribution of the PMTs dark noise counting rate.

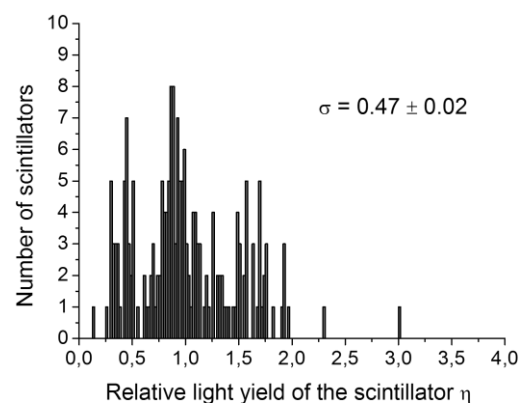

Figure 9. Distribution of the relative light yield of the scintillators.

3.2. Counter light collection non-uniformity

One of the most important tasks of the NEVOD-EAS array is to estimate the size of registered EAS which is associated with the energy deposit of the EAS fragment, fallen onto a single counter of the setup. For the accurate estimation of the energy deposit in the counter it is important that its response was independent on the place where the detected particle had passed through the scintillator. To determine the degree of the difference of the NEVOD-EAS counter response to the passage of particles through various areas of the sensitive volume of the scintillator, the light collection non-uniformity was studied. This study was performed using the muon hodoscope URAGAN [8].

Good spatial resolution of the hodoscope (1 cm for the coordinates and about 1° for the angle) enables to investigate the response of various detectors in the muon flux with known track parameters and to study in detail the structure of the scintillation counter by placing it on the surface of the hodoscope. Figure 10 shows the layout of the setup for the NEVOD-EAS counter light collection non-uniformity measurement with the coordinate detector URAGAN.

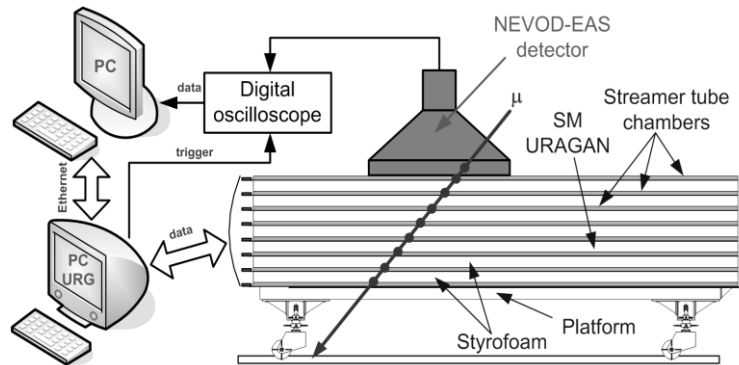

Figure 10. Layout of the setup for counter light collection non-uniformity measurement.

The main elements of this setup are: the URAGAN coordinate detector, the investigated counter, a digital oscilloscope and two computers. At the passage of the particle through the allocated triggering area, URAGAN generates a trigger signal which goes to the trigger input of the oscilloscope. On this trigger, the oscilloscope digitizes the signal of the NEVOD-EAS counter response. Then the oscilloscope buffer that stores the sweep of the counter signal is transferred to the PC. Also information about the track of the particle registered by the hodoscope is fed to the PC via Ethernet. So the event with amplitude and coordinate information is formed.

For the analysis of light collection non-uniformity of the NEVOD-EAS counter only these events in which muon has passed through the scintillator under a zenith angle less than 15° were selected.

Figure 11 shows the matrix of mean values of the charge of the counter response to the passage of single muons obtained using the URAGAN. Axes on the left bottom block of the matrix represent the geometric dimensions of the triggering area in cm. The tone shows the average charge of the detector response in pC. The top and right side blocks show the changes of the average charge of the counter response in two orthogonal sections. On the matrix this sections are marked with light lines.

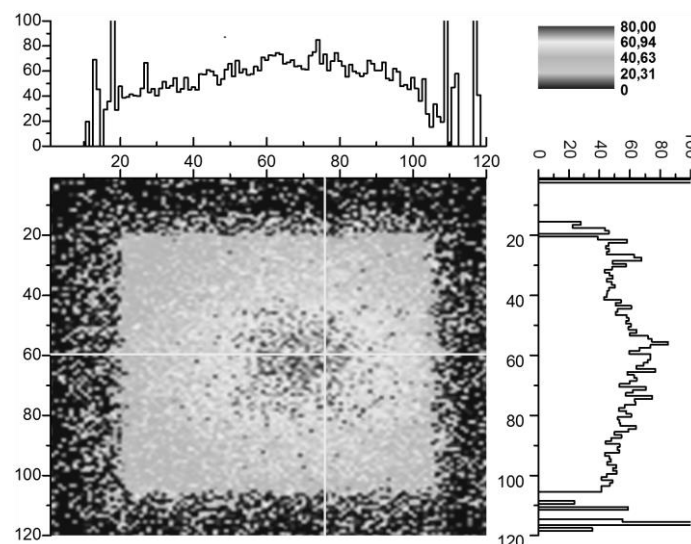

Figure 11. Matrix of the average charge of the counter response to the passage of near-vertical muons.

The increase of the counter response to particles passing through the area of the scintillator under the photomultiplier (1.5 - 2 times in comparison with the remaining area) is seen. According to this matrix, the r.m.s. light collection non-uniformity is $\sim 20\%$.

4. Assembling and adjustment of the NEVOD-EAS counter

The assembling of the NEVOD-EAS is performed using the following principle: lower light yield of the scintillator (relative to the complete sample) should be compensated by higher sensitivity of the PMT (relative to the complete sample average), and lower PMT sensitivity should be compensated by higher scintillator light yield. The selection of scintillators and photomultipliers is based on the distributions shown in figures 7 and 9. After the assembling, the most probable response of the counter to the passage of a single muon is adjusted to the value of $\sim 13 \pm 1$ pC by varying the PMT supply voltage. Such response value provides the dynamic range of the counter of up to ~ 100 detected particles (vertical equivalent muon). Figure 12 shows the charge spectra of the counter response to the passage of charged particles measured in the self-triggering mode before (a) and after (b) the adjustment. During the adjustment of this counter the supply voltage has been reduced by 105 V.

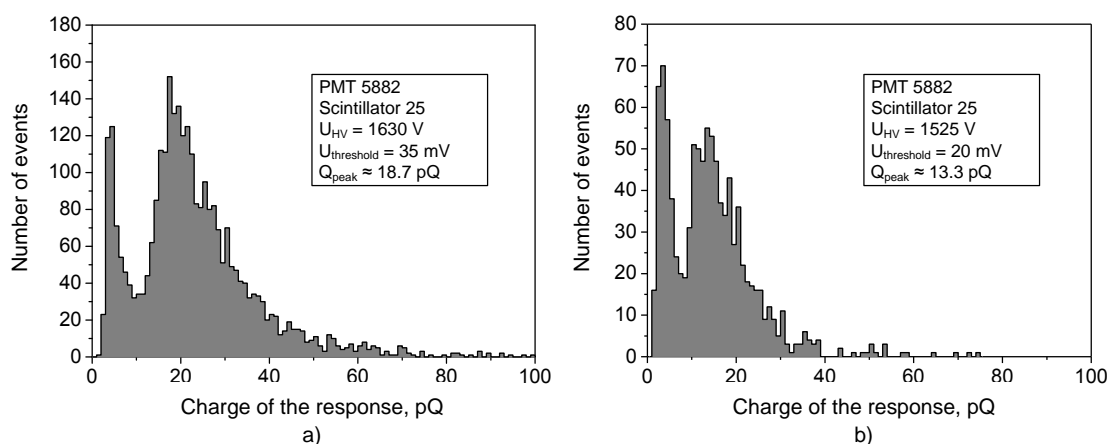

Figure 12. Charge spectra of the counter response to the passage of charged particles measured in self-triggering mode before (a) and after (b) the adjustment.

5. Conclusion

The NEVOD-EAS setup for registration of extensive air showers being created on the basis of the experimental complex NEVOD-DECOR will allow determination of the size, position of the axis and the arrival direction of EAS. The setup will be operated in conjunction with other installations of the experimental complex NEVOD and will enable to register EAS with energies of 10^{15} - 10^{17} eV, as well as to verify the technique of muon bundle registration using the DECOR detector. New data obtained with NEVOD-EAS setup will allow to reduce the energy range of PCR particles responsible for generation of muon bundles with certain multiplicity arriving at different zenith angles.

Acknowledgements

This work was performed at the NEVOD Scientific and Educational Center with the financial support from the State provided by Russian Ministry of Education and Science (government task and project No. RFMEFI59114X0002) and the grant of the Leading Scientific School NSh-4930.2014.2.

References

- [1] Aynutdinov V M *et al* 1997 *Astrophysics and Space Science* **258** 105
- [2] Khokhlov S S *et al* 2011 *Astrophys. Space Sci. Trans.* **7** 271
- [3] Barbashina N S *et al* 2000 *Instrum. Exp. Tech.* **43** 743
- [4] Bogdanov A G *et al* 2010 *Phys. Atom. Nucl.* **73** 1862
- [5] Shulzhenko I A *et al* 2013 *J. Phys.: Conf. Ser.* **409** 012098
- [6] Aglietta M *et al* 1990 *Nucl. Phys. B (Proc. Suppl.)* **16** 493.
- [7] Chiavassa A *et al* 2003 *Proc. 28th ICRC (Tsukuba)* vol 2 p 992
- [8] Barbashina N S *et al* 2008 *Instrum. Exp. Tech.* **51** 180