



Publication Year	2018
Acceptance in OA	2024-02-19T09:49:39Z
Title	Upgrading the Italian BIRALES system to a pulse compression radar for space debris range measurements
Authors	PISANU, Tonino, SCHIRRU, Luca, URRU, Enrico, GAUDIOMONTE, Francesco, ORTU, Pierluigi, BIANCHI, GERMANO, BORTOLOTTI, Claudio, ROMA, MAURO, Muntoni, G., Montisci, G., Protopapa, F., Podda, A., Sulis, A., Valente, G.
Publisher's version (DOI)	10.23919/MIKON.2018.8405212
Handle	http://hdl.handle.net/20.500.12386/34768

Upgrading the Italian BIRALES System to a Pulse Compression Radar for Space Debris Range Measurements

Tonino Pisanu, Luca Schirru, Enrico Urru, Francesco Gaudiomonte, Pierluigi Ortu
Istituto Nazionale di Astrofisica – Osservatorio Astronomico di Cagliari (INAF – OAC)
Via della Scienza 5, 09047 Selargius (CA), Italy

Giacomo Muntoni, Giorgio Montisci
University of Cagliari - Department of Electrical and Electronic Engineering (DIEE)
Via Marengo 2, Cagliari (CA), Italy

Germano Bianchi, Claudio Bortolotti, Mauro Roma
Istituto Nazionale di Astrofisica – Istituto di Radioastronomia (INAF – IRA)
Via Fiorentina 3513, 40059 Medicina (BO), Italy

Fabio Protopapa, Angelo Podda, Andrea Sulis
Vitrociset spa
Strada Statale 125 Km 78, 09040 Capo San Lorenzo Villaputzu (CA), Italy

Giuseppe Valente
Italian Space Agency (ASI)
Via del Politecnico snc, 00133 Rome, Italy

Abstract—Space debris represent a major risk for every spacecraft and satellite. In fact, other than cause serious damages to these structures, new collisions could exponentially increase the amount of debris and so the level of threat represented by the objects. To avoid new impacts, the monitoring of the space environment with space-based and ground-based measurement campaigns is necessary. The ground-based measurement can be implemented with optical or radar technologies. In this paper the upgrade of the Italian BIRALES radar system for space debris, that initially performed only Doppler measurements, is described. With its new features the BIRALES will be able to perform even range measurements.

Keywords — *space debris; bistatic radar; pulse compression radar; Northern Cross Radio Telescope; range measurements*

I. INTRODUCTION

October 1st 1957, when the first Russian satellite Sputnik was launched, set the beginning of the “Space Era”. Since then, human space missions neglected the possible congestion of the space environment caused by the operations discards. Space debris represent a serious issue for space mission security. Currently, there are more than 21,000 officially catalogued space debris in Low Earth Orbit (LEO) with size down to 10 cm. The latter are all manmade objects with variable sizes and shapes that orbit around the Earth, i.e. rocket stages, satellite fragments and other objects originated from human space activities that have ended their purpose. The problem represented by the space debris is the risk of possible collisions with spacecrafts or with other debris resulting in the creation of even new fragments [1]. One of the most used and known solutions for this problem is the collision avoidance, namely a set of countermeasures that

permits to avoid impacts between spacecraft and space debris. This procedure can be carried on by means of space-based [2] and ground-based measurements that allows to estimate the debris orbits, the collision probability, the miss distance, the approach geometry. These data are important to establish if is necessary to execute a collision avoidance maneuver on the satellite or spacecraft. In this way is possible to reduce the main problem described above.

Ground-based space debris measurements fall in two categories: optical measurements [3] and radar measurements. Radar measurements have been typically utilized to detect objects in LEO between 200 and 2000 km [4], [5] while optical measurements are preferred for higher orbits. The reason of this discrepancy is strictly tied to the operational conditions of the two types of measurement, highly dependent on power budget in the first case and on the “environmental conditions” in the second (e.g. weather conditions, time of the day, etc.).

In order to prevent the space debris problem, in 2015 the European Commission started a dedicated framework for Space Surveillance and Tracking (SST). Within this framework, a network of dedicated sensors for the surveillance and the tracking of objects in LEO has been implemented. Among the sensors selected for the network, the Italian radar Bistatic Radar for LEO Survey (BIRALES) has been chosen to monitor the space environment in survey mode. This system is a P band (at 410 MHz) bi-static radar composed by a transmitter antenna situated in the Italian Joint Test Range in the region “Salto di Quirra” (Cagliari, Sardinia) and the Northern Cross Radio Telescope as a receiver antenna situated in Medicina (Bologna, Emilia-Romagna). The BIRALES system can generate a set of data concerning every debris

observed, i.e. Doppler shift, illumination time and measured power intensity [6].

In this paper the upgrade of the BIRALES system to a pulse compression radar that permits to implement space debris range measurements is presented. In this way, is possible to improve the knowledge of the orbit of the space debris observed in the measurement campaign [7].

II. BIRALES ARCHITECTURE

The BIRALES system is a bistatic radar composed by two distinct antennas (see Fig. 1), the transmitter and the receiver, with a baseline of about 580 km.

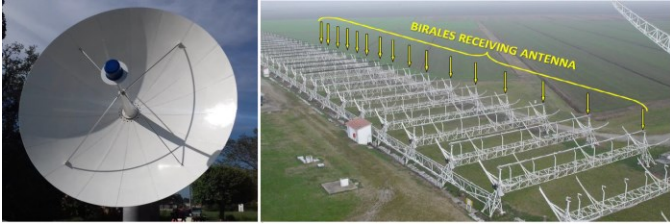

Fig. 1. BIRALES transmitter and receiver.

A. Transmitter system

The transmitter is the Radio Frequency Transmitter (TRF) located in Italian Joint Test Range in the region “Salto di Quirra” (Cagliari, Sardinia). It is a 7 m dish fully steerable wheel-and-track parabolic antenna (see Fig. 1), with a maximum speed of 3 deg/sec. Fundamentally, the system is composed by a set of powerful amplifiers, installed in a cooled shelter, able to supply a maximum power of 10 kW in the bandwidth 410-415 MHz. In greater detail, there is a control unit (CCU) in Fig. 2) that takes as input the signal generated by a vector signal generator. The CCU is connected with the Automatic Gain Control (AGC) that permits to send the signal to the radio frequency splitter. This block creates seven signals, that previously entered in a phase adjust block, each one for every power amplifier available (with nominal power of 2 kW). After the amplification block, the signals are combined, filtered and sent to the antenna.

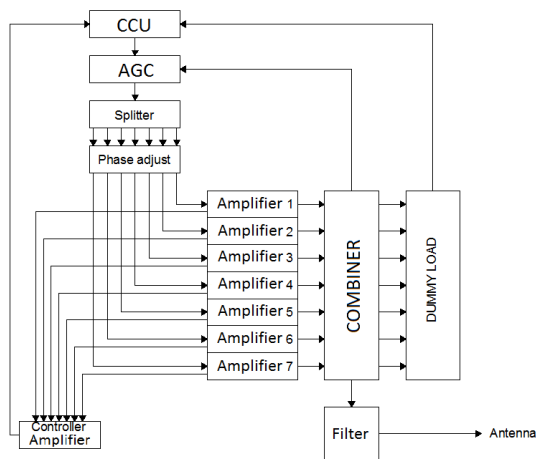

Fig. 2. Block diagram of the transmitter system.

To date, the transmitter has been employed in Continuous Wave (CW) mode and, consequently, this prevented the measurement of the object range, but allows only the Doppler shift and Signal-to-Noise ratio (SNR) received measurements.

B. Receiver system

The receiver is a portion of the Northern Cross Radio Telescope (see Fig. 1) situated at the Medicina Radio Astronomical Station, close to Bologna (Emilia-Romagna). This is currently one of the largest UHF-capable antenna in the world. It consist of two perpendicular branches: the East-West (E/W) one is 564 m long and consists of a single cylindrical antenna with a width of 35 m, whereas the North-South (N/S) branch is made of 64 parallel antennas with a length of 23.5 m and width of 7.5 m each. The portion dedicated for the BIRALES receiver is actually composed of 16 parabolic cylindrical antennas of the N/S branch, with a total collecting area of about 2800 square meters and with a Field of View (FoV) of $6.6^\circ \times 2.2^\circ$. The signals received from these 16 antennas are converted in optical fiber and sent to the receiving room. In this state, the signals are reconverted in electric signals with a bandwidth of 16 MHz at 410 MHz and down converted at an intermediate frequency (IF) of 30 MHz with a bandwidth of 5 MHz.

The BIRALES system works in survey mode and exploits an innovative concept based on multi-beam technique. In fact, there are four receivers in each N/S antenna for a total of 64 receivers used in BIRALES receiver, that permit to populate the antenna FoV with many independent beams. When a space debris transits inside the antenna FoV, its echo radar illuminates a certain number of beams. Thus, by looking at the beam illumination sequence, it is possible to estimate the ground track of the transiting objects, with a higher level of details with respect to a single-beam system. The information about the sequence of illuminated beams allows to recognize the trajectory of the object with an estimated orbit accuracy below 100 m.

III. UPGRADING THE BIRALES SYSTEM TO A PULSE COMPRESSION RADAR

As described above, the original BIRALES system worked in CW mode. This configuration prevented range measurements and allowed only Doppler shift and received SNR measurements. In this paper, an upgrade of the BIRALES system to a pulse compression radar [8] is proposed, in order to detect debris at range equal to 2000 km with a measurement accuracy of about 30 m. To perform this type of measurements a pulse repetition frequency (PRF) [8] of

$$PRF = c/2d \cong 70 \text{ Hz} \quad (1)$$

is necessary, where c is the speed of light and d is the maximum range, in this case equal to 2000 km. This value of PRF prevents the possibility of Doppler measurement with this pulse compression radar because typical space debris Doppler measurements in LEO are in the order of few kilohertz. With this upgrade, the system will be able to work

as a pulsed radar (for range measurement) and as CW radar (for Doppler measurement). To obtain a proper SNR at the receiver, the duration of the pulse, that later will be compressed, is of about 200-500 microsecond. The duration t of the compressed pulse is dictated by the already mentioned measurement accuracy and is given by

$$t = 2r/c \cong 200 \text{ ns} \quad (2)$$

where r is the measurement accuracy equal to 30 m.

The overall performance of the bistatic radar is determined by the precision in the synchronization between transmitter and receiver blocks. In this respect, a maximum error of 10^{-7} s is guaranteed by an integrated GPS hardware, installed in every block. Moreover, transmitter and receiver must communicate to exchange essential information such as the parameters of the transmitted signal, the pointing coordinates of the transmitting antenna and the start epoch of the transmission. Sharing this information is crucial for the evaluation of the correlation between the transmitted signal and the received signal.

A. Upgrade of the transmitter system

The upgraded transmitter architecture is composed by a workstation and a commercial Field Programmable Gate Array (FPGA) board named USRP (see Fig. 3).

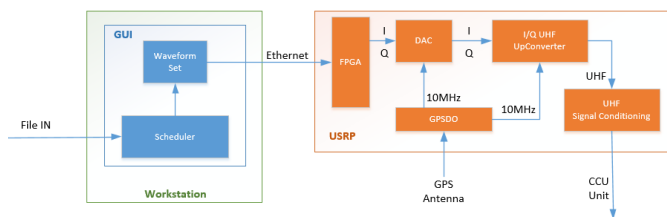

Fig. 3. The transmitter architecture.

The transmitter Workstation block is composed by the Scheduler and the Waveform Set. The Scheduler generates the data that will be shared with the receiver, i.e. the epoch, the transmission start and stop time, the signal power, the signal frequency, the pointing coordinates of the antenna and the waveform parameters (pulse repetition frequency, pulse duration, etc.). The Waveform Set allows the creation of the waveform following the characteristics defined in the Scheduler. The Workstation block synthesizes the I/Q signal in baseband and sends it to the USRP block via Ethernet connection. The USRP block generates the UHF signal to be sent to the CCU block depicted in Fig. 2. Inside the USRP block of the transmitter, the FPGA mixes, filters and interpolates the signal received by the workstation through a Digital Up-Converter (DUC). The Digital-to-Analog Converter (DAC) executes the signal conversion from digital to analogic with 16 bit. Inside the I/Q UHF Up-Converter, that up converts the signal to a radio frequency one, a low pass filter reduces the overall noise. The GPS-Disciplined Oscillator (GPSDO) guarantees the internal synchronization at 10 MHz and the synchronization with the receiver system. The

UHF Signal Conditioning amplifies the signal and sends it to the CCU block (see Fig. 2) for a further amplification and the final transmission.

B. Upgrade of the receiver system

The hardware architecture of the upgraded receiver system is similar to the transmitter (see Fig. 4). The received signal, at an IF of 30 MHz with a bandwidth of 5 MHz, enters in the USRP block of the receiver for the down conversion and the digitalization. This block works in a specular way with respect to the USRP block of the transmitter.

The receiver Workstation block is quite different from the transmitter. The schematic of the block is depicted in Fig. 4. The correlation process that allows the development of a matched filter [8] for the radar waveforms is possible thanks to a Pulse Compressor. The characteristics of the pulse compression depends from the knowledge of the transmitted pulse. In fact, the greater the knowledge of the transmitted pulse, the greater the quality of the pulse compression. The Coherent Integrator samples and adds the signals returning from each one of the N transmitted pulses at a spacing equal to the range resolution of the radar. After it accumulates the N pulse sum, it performs the amplitude detection and threshold check. The difference in time (or frequency) between the returning pulses can give the Doppler shift of the pulses. This range-Doppler map can be analyzed by the Extractor for the identification of possible targets. At this point the bistatic range measurement can be performed.

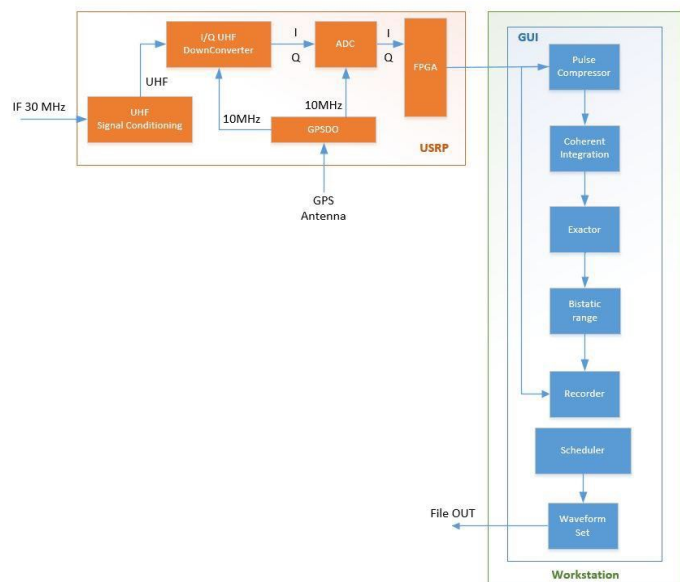

Fig. 4. The receiver architecture.

The control software is provided with an “ad hoc” Graphic Unit Interface (GUI). Although the software is the same for transmitter and receiver, the GUI is different. A lighter and more simple version on the transmission side while for the receiver, do to the data processing functions, a more complex one. The basic macro functions (available for both the transmitter and the receiver) are the Scheduler, the Waveform

Set and the Diagnostic; the additional macro functions for the receiver are the Player and the Post processing (see Fig. 5).

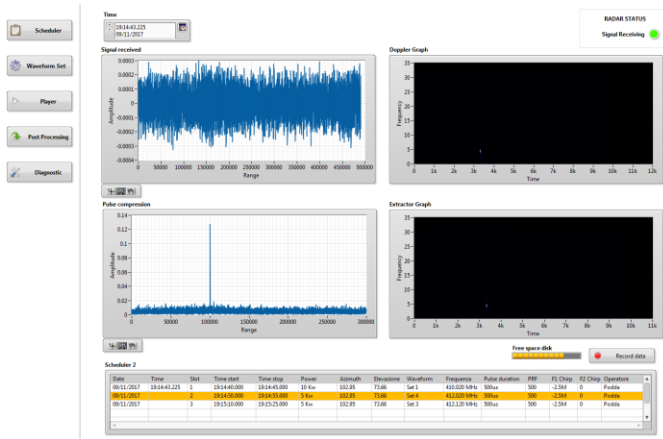

Fig. 5. Example of the receiver GUI.

IV. CONCLUSION

In this work the upgrade of the BIRALES system for space debris range measurements is presented. Thanks to the upgrade, the system will be able to work as a pulsed radar other than CW radar. The key point of the upgrade is the synchronization between the transmitter and the receiver that has to ensure a maximum error of 10^{-7} s. By means of the modification of the system will be possible to perform bistatic range measurements of the space debris.

Acknowledgment

We want to acknowledge the company Vitrociset spa for the good prototype realized with the subcontract "Common upgrading of receiving elements of BIRALES and

BIRALET", funded by the H2020 Action of European Commission in the framework of the SST Grant Agreement 713762-3SST2015.

References

- [1] G. Muntoni, L. Schirru, T. Pisanu, G. Montisci, G. Valente, F. Gaudiomonte, G. Serra, E. Urru, P. Ortu, A. Fanti, "Space debris detection in Low Earth Orbit with the Sardinia Radio Telescope", *Electronics*, 6(3), 59, August 2017.
- [2] H. Kayal, "A nano satellite constellation for detection of objects in earth orbit", 4th International Conference on Recent Advances in Space Technologies, Istanbul, Turkey, 11-13 June 2009, pp. 95-99.
- [3] F. Piergentili, A. Ceruti, F. Rizzitelli, T. Cardona, M. L. Battagliere, F. Santi, "Space debris measurement using Joint Mid-Latitude and Equatorial Optical observations", *IEEE Transactions on Aerospace and Electronic Systems*, vol. 50 (1), pp. 664-675, 2014.
- [4] M. Grassi, E. Cetin, A. G. Dempster, "Enabling orbit determination of space debris using narrowband radar", *IEEE Transactions on Aerospace and Electronic Systems*, vol. 51 (2), pp. 1231-1240, 2015.
- [5] J. Zhu, S. Zhu, G. Liao, "High-resolution radar imaging of space debris based on sparse representation", *IEEE Geoscience and Remote Sensing Letters*, vol. 12 (10), pp. 2090-2094, October 2015.
- [6] A. Morselli, P. Di Lizia, G. Bianchi, C. Bortolotti, S. Montebugnoli, G. Naldi, F. Perini, G. Pupillo, M. Roma, M. Schiaffino, A. Mattana, E. Salerno, A. Magro, K. Z. Adami, R. Armellin, A. Lazzareschi Sergiusti, W. Villadei, F. Dolce, M. Reali, J. Paoli, "A new high sensitivity radar sensor for space debris detection and accurate orbit determination", In *Proceedings of the 2015 IEEE Metrology for Aerospace (MetroAeroSpace)*, Benevento, Italy, 4-5 June 2015, pp. 562-567.
- [7] A. Morselli, R. Armellin, P. Di Lizia, B. Zazzera, E. Salerno, G. Bianchi, S. Montebugnoli, A. Magro, K.Z. Adami, "Orbit determination of space debris using a bi-static radar configuration with a multiple-beam receiver", In *Proceedings of the International Astronautical Congress, IAC 2014, Toronto, Canada, 29 September-3 October 2014*; pp. 1-11.
- [8] M. I. Skolnik, *Radar Handbook*. McGraw-Hill, Boston, Massachusetts, 1990.