



| | |
|----------------------------------|--|
| Publication Year | 2022 |
| Acceptance in OA | 2024-02-14T12:14:39Z |
| Title | Status of the multibeam S band receiver for the Sardinia Radio Telescope |
| Authors | PISANU, Tonino, Valente, G., MARONGIU, Pasqualino, MAXIA, PAOLO, ORTU, Pierluigi, NAVARRINI, Alessandro, LADU, Adelaide, SCHIRRU, Luca, Ghiani, R., CONCU, Raimondo, GAUDIOMONTE, Francesco, Angius, G., CABRAS, Alessandro, EGRON, Elise Marie Jeanne, Iacolina, N., VACCA, VALENTINA |
| Publisher's version (DOI) | 10.23919/AT-AP-RASC54737.2022.9814341 |
| Handle | http://hdl.handle.net/20.500.12386/34754 |



Status of the multibeam S band receiver for the Sardinia Radio Telescope

T. Pisanu^{* (1)}, G. Valente⁽²⁾, P. Marongiu⁽¹⁾, P. Maxia⁽¹⁾, P. Ortu⁽¹⁾, A. Navarrini⁽¹⁾, A. Ladu⁽¹⁾, L. Schirru⁽¹⁾, R. Ghiani⁽²⁾, R. Concu⁽¹⁾, F. Gaudiomonte⁽¹⁾, G. Angius⁽¹⁾, A. Cabras⁽¹⁾, E. Egron⁽¹⁾, N. Iacolina⁽²⁾, V. Vacca⁽¹⁾

(1) INAF- Cagliari Astronomical Observatory, via della Scienza n. 5, 09047 Selargius (CA), e-mail: tonino.pisanu@inaf.it;

(2) ASI - Italian Space Agency, Via del Politecnico snc 00133 - Roma (RM), Italy, giuseppe.valente@asi.it

Abstract

We describe the development status of the S-band (3-4.5 GHz) seven-beam cryogenic receiver for the primary focus of the Sardinia Radio Telescope (SRT). The main scientific goals for the SRT at S-band include the search for new pulsars, the evaluation of the pulsar dispersion for gravitational wave measurements, the mapping of galactic supernova remnants, and the study of magnetic field of galaxy clusters.

1. Introduction

In this paper, we present the updated design version of the S band seven-beam receiver for SRT, which is currently in a very advanced development phase. Several modifications and improvements have been made in this final receiver version compared to previous ones. The most important changes concern the RF front-end chain and the cryostat, whose designs have been modified to get an easier construction and assembly procedure. We will provide a detailed description and simulation of the whole modified receiver chain.

The SRT [1] is a 64-meter diameter fully steerable radio telescope (Figure 1) currently equipped with four cryogenic receivers [2]: the primary focus L-P-band (1.31.8 GHz, 305-410 MHz) coaxial receiver, the Gregorian focus K-band (1826.5 GHz) seven-beam receiver, and the Beam Waveguide C-band (5.7-7.7 GHz) and X-band (8.28.6 GHz) receivers.



Figure 1. Sardinia Radio Telescope

By the end of 2022, we plan to install four additional receivers [3] in the Gregorian focal position: a W-band (70116 GHz) 16-beam receiver, a Q-band (33-50 GHz) 19beam receiver, a W-band (77-103 GHz) bolometric camera and a simultaneous triple band system operating in the K- Q- and W- bands (18-26 GHz, 34-50 GHz and 80-116 GHz).

Thanks to its seven dual-linearly polarized beams and its predicted low system noise temperature, the S-band receiver will enable the SRT to carry out fast mapping of weak radio astronomy sources over large areas of the sky. It will be an extremely valuable receiver to add to the well-equipped SRT instrumentation pool, that will enable conducting forefront scientific discoveries in a not yet well-explored frequency range of the radio frequency spectrum.

2. The S band receiver

A first design version of the S-band receiver is described in [4], where the authors analyzed the status of the RFI situation at the SRT site, the electromagnetic analysis of the feed for an optimal aperture efficiency, the spatial configuration and the maximum number of feeds for the SRT optical configuration. After a series of studies, a new upgraded version of the system was presented in [5], with a detailed description of the front-end, focusing on the electromagnetic, electronic, cryogenic, mechanical and thermal designs and laboratory measurements. In [5], the authors shifted the operating frequency band from 2.3-4.3 GHz to 3.0-4.5 GHz, due to the presence of new relatively strong radio frequency interferences (RFIs) that had not been detected in previous RFI campaigns. The S-band feeds are arranged in a compact hexagonal configuration with a central one and with a single external corrugation. The feeds are placed at the telescope primary focus focal plane. The receiver includes a mechanical derotator (visible in Figure 7: Mechanical derotator) allowing to rotate the cryostat (with the seven feeds) and track the parallactic angle. The electromagnetic simulations of the SRT telescope

optical performance illuminated with the array feeds were presented in [6].

Figure 2 shows one of the seven dual linear polarization RF feed-horns of the receiver, consisting of a circular waveguide feed with 64 mm aperture diameter, a circular to quad-ridge waveguide transition and the orthomode transducer with four output ports. The total length of the feed system is 302.8 mm. The main changes with respect to the architecture presented in [5], is the fact that the feeds are now external to the cryogenic section. This modification was necessary to improve the illumination of the primary reflector and avoid beam truncation problems that were identified through simulations to limit the optical performance and the SRT antenna efficiency. Also, the modification allowed to reduce the size of the vacuum window and ease the assembly of the parts. To do this, it was necessary to include two thermal gaps in the feed chain, one to isolate the ambient temperature feeds section from the 70 K quad-ridge section, and the other to isolate the 70 K from the 20 K OMT section.

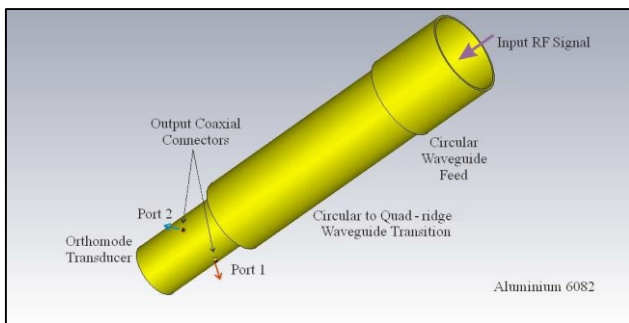

Figure 2. RF Front end of the receiver

The OMT section incorporates four output coaxial ports (only two are visible in Figure 2), two for extracting the Horizontal and the Vertical linear polarizations, and the other two to inject a noise source calibration signal (one per polarization channel).

In Figure 3, we present the full architecture of one of the seven chains of the receiver. The main sections are the RF cryogenic front end section, the noise generator section, the Local Oscillator (LO) distribution, and the two (Horizontal and Vertical) down converting sections.

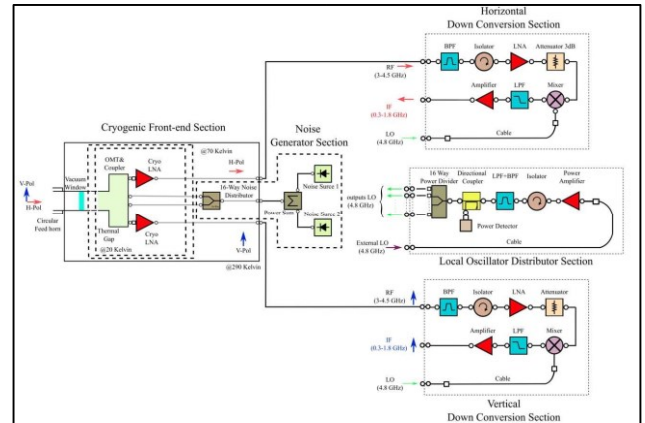

Figure 3. Schematic of the full S band receiver.

The signal extracted from the OMT will be amplified by a commercial LNA in the cryogenic section and later down converted to the IF frequency range of 0.3 – 1.8 GHz by a mixer pumped with a 4.8 GHz local oscillator. In the following Figure 4 you can see an internal view of the cylindrical cryogenic dewar where is easy to identify in yellow the seven feeds, in green the isolating fiberglass supports used to create a thermal separation between the 300 K, 70 K and 20 K temperature sections and in brown the copper contacts between the LNA's and the 20 Kelvin cold head stage.

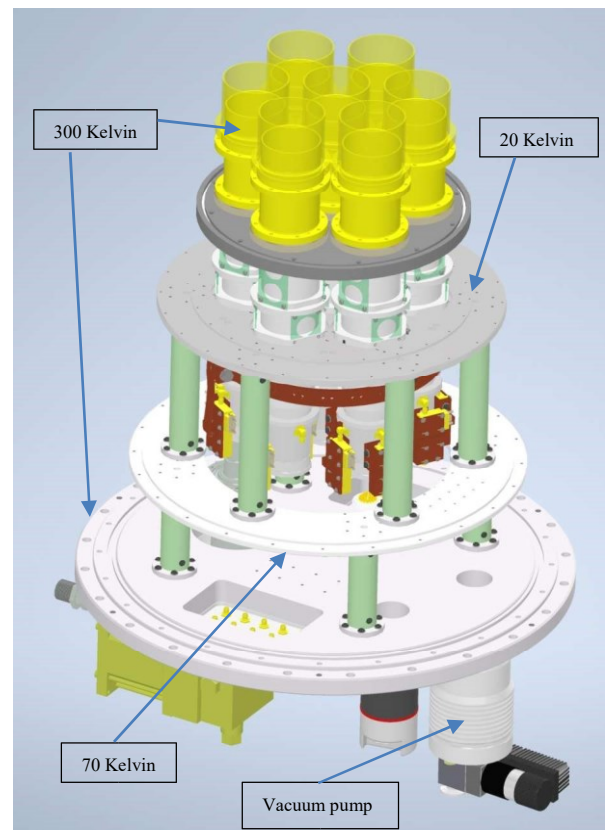

Figure 4: Internal view of the dewar section

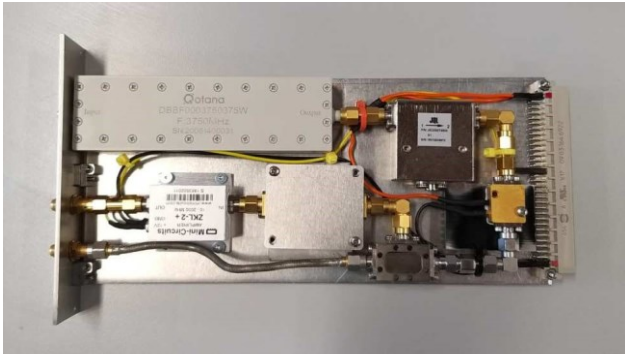

Figure 5: assembled RF down converting board

The conversion system designed is composed of commercial and homemade devices [11], in Figure 5 we show the first prototype of one of the 14 down-conversion boards. The system was measured with a local oscillator @ 4.8 GHz to allow us place the RF bandwidth of 1.5 GHz into the IF bandwidth of SRT (0.1-2.1 GHz). The measurement was conducted into the laboratory at the observatory of Cagliari, and the author used a spectrum analyzer and two signal generators to measure the conversions gain of the down-conversion chain. The measurement was done with an automatic test bench [12] which controlled different radio frequency instrumentation and allowed us the processing of data after the measurements. For the measurements, the author estimated a maximum power signal at the input of the conversion system equal to -45dBm and a 10dBm power at 4.8 GHz for the local oscillator. The resulting conversion gain is shown in Figure 6 and the value is about 53dB.

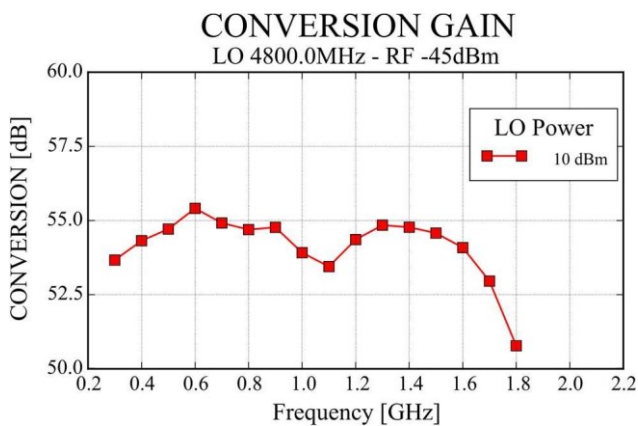

Figure 6: Measured conversion Gain of whole down conversion system

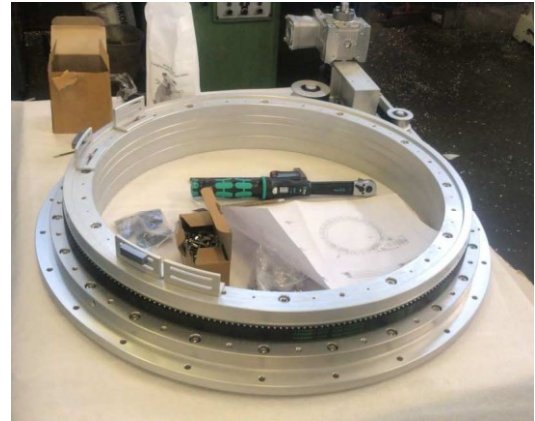

Figure 7: Mechanical derotator

3. Conclusion

The S-band seven beam multifeed receiver for the primary focus of the SRT is in a well advanced construction phase. We modified the instrument design with respect to a previous version, as we identified issues related to blockage of the beams radiated by the feed due to the cryostat. The design modification allowed to reduce the vacuum window size and simplify the fabrication and assembly procedure of the feed system. The RF front end chain is now well defined and we are working to finalize the mechanical design and construction procedures. All the components to build the down conversion and local oscillator distribution sections have already been purchased and are available in our laboratory. The mechanical derotator has been fabricated. Our next steps are to complete fabrication of the cryostat and of its mechanical interface support structure to which the receiver will be bolted to hold it in place at the defined primary focus of the SRT. The conversion section is finalized and full characterized.

The assembly and test of the seven receiver sections is about to start. The front ends will be tested separately, before the final construction and test of the full receiver.

References

- [1] P. Bolli et al., "Sardinia Radio Telescope: General Description, Technical Commissioning and First Light," *Journal of Astronomical Instrumentation*, 4, 1550008-880, Jan. 2016, DOI: 10.1142/S2251171715500087.
- [2] A. Navarrini et al., "Front-Ends and Phased Array Feeds for the Sardinia Radio Telescope," *Proceedings of 32nd URSI GASS Conference*, Montreal, 19-26 August 2017.
- [3] F. Govoni et al., "The high-frequency upgrade of the Sardinia Radio Telescope," *Journal of Astronomical*

Instrumentation, Vol. 4, (2015) doi:
10.23919/URSIGASS51995.2021.9560570.

- [4] G. Valente et al. "A Multifield S-Band Cryogenic Receiver for the Sardinia Radio Telescope Primary Focus", Proceedings of SPIE Vol. 9153, 2014 – Montreal, Quebec, Canada, doi: 10.1117/12.2056557.
- [5] G. Valente et al. "The 7-beam S-band cryogenic receiver for the SRT primary focus: project status" Proceedings of SPIE Vol. 9914, 20 July 2016 – Edinburgh, United Kingdom, doi: 10.1117/12.2232625.
- [6] A. Navarrini et al., "Optical design of S-band multifield for the Sardinia Radio Telescope primary focus" NEMO2017 IEEE MTT-S International Conference on Numerical Electromagnetic and Multiphysics Modeling and Optimization for RF, Microwave, and Terahertz Applications, May 17-19, 2017, Sevilla, Spain.
- [7] G. Valente et al., "The Coaxial L-P Cryogenic Receiver of the Sardinia Radio Telescope" December 2021 IEEE Access PP(99) DOI: 10.1109/ACCESS.2021.3139744.
- [8] A. Orfei et al., "A Multi-Feed Receiver in the 18 to 26.5 GHz Band for Radio Astronomy" September 2010 IEEE Antennas and Propagation Magazine 52(4):62 – 72 DOI: 10.1109/MAP.2010.5638236
- [9] G. Valente et al., "Status of the radio receiver system of the Sardinia Radio Telescope", Proc. SPIE 9914, Millimeter, Submillimeter, and Far-Infrared Detectors and Instrumentation for Astronomy VIII, 991425 (20 July 2016); <https://doi.org/10.1117/12.2232880>
- [10] G. Valente, "Sardinia deep space antenna: Current program status and results," in Proc. 70th Int. Astron. Congr. (IAC), Washington, DC, USA, Oct. 2019, pp. 21–25.
- [11] S. Dessi, et al "Low Cost Elliptic Filter for Wireless Application", 22nd Telecommunication forum TELFOR 2014, Serbia; Belgrade, Nov. 25-27, 2014.
- [12] A. Saba, G. Valente, "RFLab" OAC Internal Report N.60 December 2016;