



Publication Year	2020
Acceptance in OA	2021-08-27T10:54:07Z
Title	Use of the Peak-Detector mode for gain calibration of SiPM sensors with ASIC CITIROC read-out
Authors	IMPIOMBATO, Domenico, SEGRETO, ALBERTO, CATALANO, OSVALDO, GIARRUSSO, SALVATORE, MINEO, TERESA
Publisher's version (DOI)	10.1088/1748-0221/15/04/C04007
Handle	http://hdl.handle.net/20.500.12386/30985
Journal	JOURNAL OF INSTRUMENTATION

15TH TOPICAL SEMINAR ON INNOVATIVE PARTICLE AND RADIATION DETECTORS
14-17 OCTOBER 2019
SIENA, ITALY

Use of the Peak-Detector mode for gain calibration of SiPM sensors with ASIC CITIROC read-out

D. Impiombato,^{a,1} A. Segreto,^a O. Catalano,^a S. Giarrusso,^a and T. Mineo^a on behalf of the ASTRI Project

^aINAF, Istituto di Astrofisica Spaziale e Fisica Cosmica di Palermo, via U. La Malfa 153, I-90146 Palermo, Italy

E-mail: Domenico.Impiombato@inaf.it

ABSTRACT: The ASIC CITIROC is a 32-channel fully analogue front-end ASIC dedicated to the read-out of silicon photo-multiplier (SiPM) sensors that can be used in a variety of experiments with different applications: nuclear physics, medical imaging, astrophysics, etc. For each channel, two parallel AC coupled voltage preamplifiers, one for the high gain and one for the low gain, ensure the read-out of the charge from 160 fC to 320 pC (i.e. from 1 to 2000 photo-electrons with SiPM gain = 10^6 , with a photo-electron to noise ratio of 10). The signal in each of the two preamplifier chains is shaped and the maximum value is captured by activating the peak detector for an adjustable time interval. In this work, we illustrate the peak detector operation mode and, in particular, how this can be used to calibrate the SiPM gain without the need of external light sources. To demonstrate the validity of the method, we also present and discuss some laboratory measurements.

KEYWORDS: Front-end electronics for detector read-out, Photon detectors for UV-visible and IR photons (solid-state)-Solid state detectors

¹Corresponding author.

Contents

1	Introduction	1
2	The CITIROC chip	2
3	The Peak detector mode	3
4	Peak detector output	4
5	Dark count spectra	6
6	Evaluation of the pixel gains using the peak detector	8
7	Conclusion	10

1 Introduction

The calibration of the signals of any Cherenkov camera is of considerable importance for the proper reconstruction of the recorded images. A suitable calibration procedure involves measurements of the pixel electronics baseline, the linearity, the uniformity of the response to incident light, and the value of the equivalent photo-electrons (pe), typically expressed in terms of analog-to-digital (ADC) counts. Usually silicon photo-multipliers (SiPMs) have a good amplitude resolution showing a peaked distribution for multiple photo-electron entries, thanks to a very low excess noise factor resulting from the Geiger mode operation and a high uniformity in the response of the individual micro-cells of each SiPM pixel. One of the techniques that allows the gain calibration of a Cherenkov camera without the need of an external light source is based on dark acquisitions runs. In dark spectra one can observe a percentage of events with amplitudes larger than one photo-electron because of the so-called optical cross-talk effect. Secondary photons [1] emitted in the primary avalanche can reach neighboring micro-cells, either directly or after a reflection, and trigger avalanches almost simultaneously to the primary one. This gives rise to high-amplitude pulses equivalent to the one produced by several incident photons. The dark spectrum shows therefore several peaks (with a Gaussian shape, to a good approximation) where the distance between two neighboring peaks corresponds to the pixel gain.

2 The CITIROC chip

The CITIROC (Cherenkov Imaging Telescope Integrated Read Out Chip) [2, 3], designed by WEEROC¹, is a 32-channel fully analogue front-end ASIC dedicated to the SiPM sensors read-out. It is designed with a 0.35 μm SiGe technology from AustriaMicroSystems. It is an evolution of the EASIROC (the Extended Analogue Silicon photo-multiplier Integrated Read Out Chip)[4–8] which was available since 2010 and used in a variety of nuclear physics and astrophysics and medical imaging applications. It has been adopted as front-end for the focal plane detectors of the ASTRI-Horn Cherenkov telescope [9, 10] and, in this context, it was modified implementing the peak detector reading mode to satisfy the instrument requirements. However, due to the low cross-talk probability of the today SiPMs and the CITIROC architecture, which adopts a multiplexed readout, long acquisition time are required in order to accumulate spectra with sufficient statistics in the peaks for an accurate determination of pixel gains. It is however possible to solve the problem, by means of a proper use of the peak detector mode implemented in the readout chip. Fine-tuning of each pixel gain is obtained adjusting the voltage applied to the SiPM through an 8-bit Digital-to-Analog Converter (DAC) ranging from 0 to 4.5 V. For each channel, two parallel AC coupled voltage preamplifiers the High Gain (HG) and Low gain (LG) electronics chains ensure the read out of the charge from 160 fC to 320 pC (i.e. from 1 to 2000 photoelectrons with SiPM Gain = 10^6 , with a photo-electron to noise ratio of 10). Two operation modes are implemented in the ASIC: the peak detector and the Track&Hold circuit. The peak detector mode provides the maximum pulse height reached by the signal in a predefined time window (plus an electronics offset from the circuit), whereas the Track&Hold mode returns the level of the shaped pulse height at the given sampling time. The analog processed data of the 32 channels are readout, in a multiplexed way, by two external Analog-to-Digital Converter (ADC). The trigger path that can be switched between either the LG or HG preamplifiers is composed of a 15 ns peaking time fast shaper followed by two discriminators. One discriminator provides trigger and hit information, with a programmable mask to block unwanted channels, while the other provides accurate time information. An internal 10-bit threshold common to all 32 channels can be set for each of the two discriminators. Fine-trimming of each channel's discriminator is also possible with a 4-bit DAC. The 32 analogue channel paths are multiplexed into one output each for HG and LG (see Fig. 1)

¹<http://www.weeroc.com>

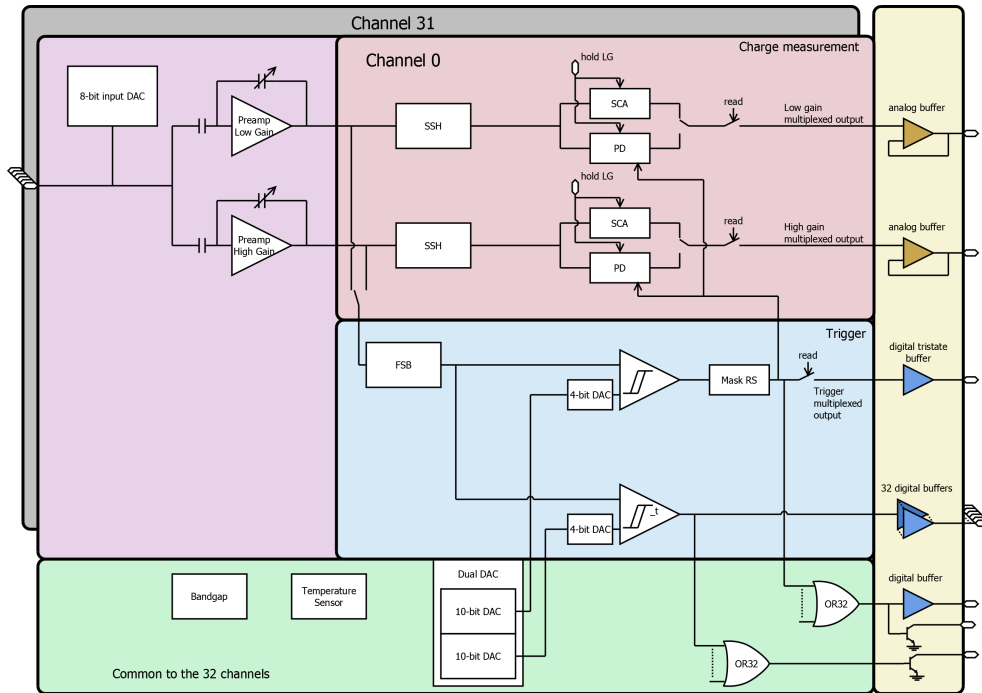

Figure 1. Architecture of the front-end CITIROC showing the presence of two alternative processing blocks, the Peak Detector (PD) and the Track&Hold (SCA) (courtesy of WEEROC).

3 The Peak detector mode

The peak detector working mode implemented in CITIROC is illustrated in Fig. 1. The signal generated by the SiPM is shaped with a time constant that can be varied from 12.5 to 87.5 ns, depending on the user requirements (black curve in Fig. 2). The peak detector is activated, within a few ns, by a "trigger signal" (red curve in Fig. 2) and is stopped after a predefined selectable delay, by the rising edge of the "hold signal" (blue curve in Fig. 2). During the "hold" signal the ADC conversion of the peak detector output is performed. The falling edge of the "hold" signal switches the chain back to track phase for the next acquisition. The delay between the trigger and the hold signals can be varied up to a few microsecond depending on the application of the ASIC.

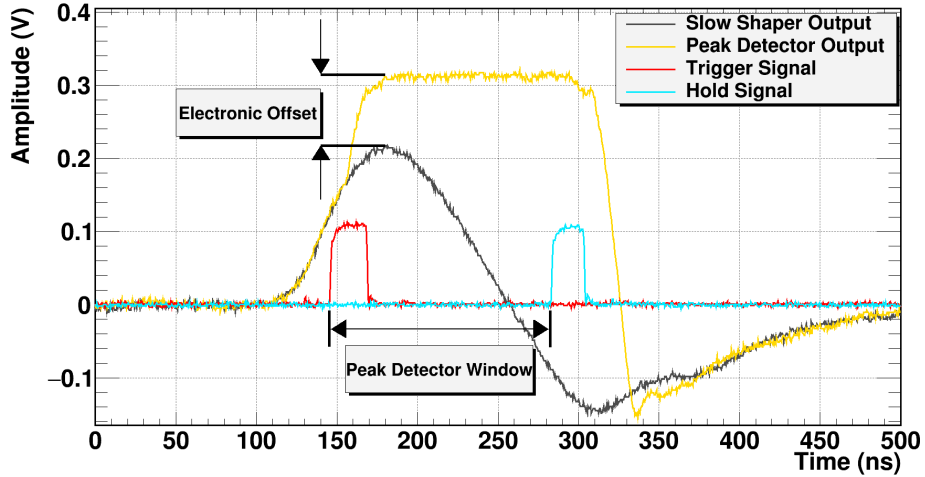

Figure 2. Analog output of CITIROC signals in peak detector working mode. The black curve shows a SiPM pulse signal after the slow shaper as observed in Track&Hold operation mode. The yellow curve shows the output signal observed when the peak detector circuit is first activated by a trigger signal (the red curve) and then disabled by the falling edge of the hold signal (the blue curve).

4 Peak detector output

To study the characteristics of the peak detector output when multiple pulses at close time distance are generated by the SiPM, we injected into one channel of CITIROC an electronic signal simulating four pulses, with different amplitudes, by using a pulse-function generator. The shape of the four pulses was tailored to the shape of a real SiPM output pulse i.e. with a very fast rise time (a few hundreds of ps) followed by an exponential decay with a time constant of about 150 ns (see Fig. 3). The trigger and hold signals, provided by the pulse generator, were used to activate/deactivate the peak sensing circuit of the ASIC. The delay of the hold signal was set to a value of about 2550 ns so that all the four simulated pulses were inside the peak detector activation time window. As shown in Fig. 4, the peak detector output depends only on the pulse with the highest amplitude. In Fig. 5 we show the peak detector analog output as observed with real SiPM pulses generated in dark conditions.

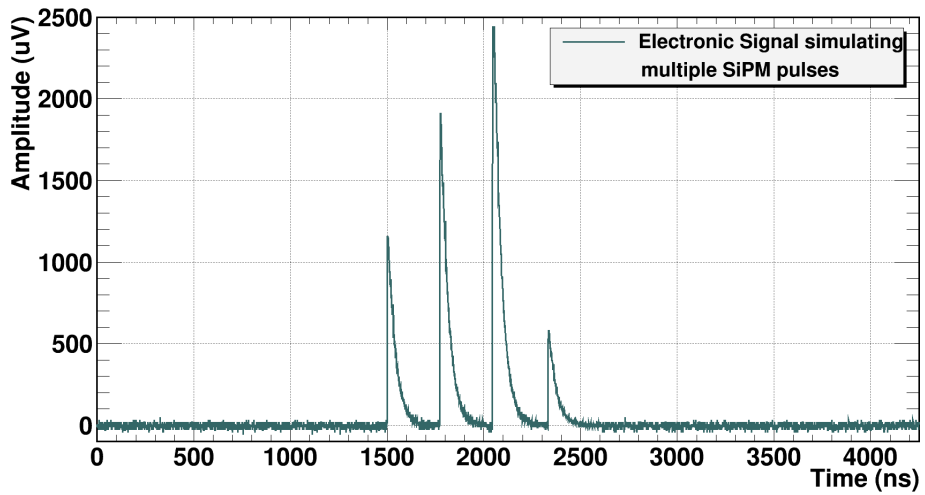

Figure 3. Electronic signal injected into an ASIC channel to study the peak detector output in presence of multiple SiPM pulses detected within short time distance.

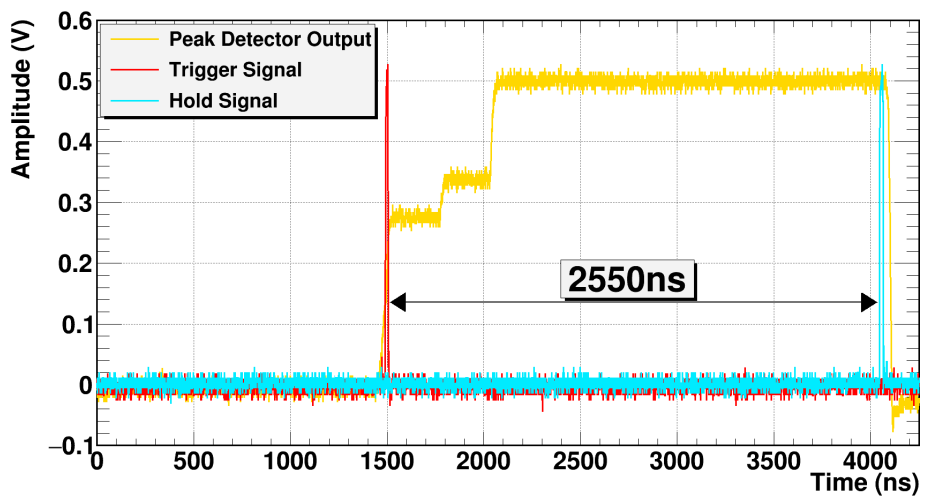

Figure 4. Peak detector analog output when an electronic signal with multiple pulses (having different amplitudes) is injected. The yellow curve shows the analog signal of the peak detector. The red and blue curves are the trigger and hold signals, injected from the pulse generator. As evident, after the injection of the highest amplitude pulse, the peak detector output stays constant, without any appreciable decay in the considered time intervals, until the falling edge of the Hold signal.

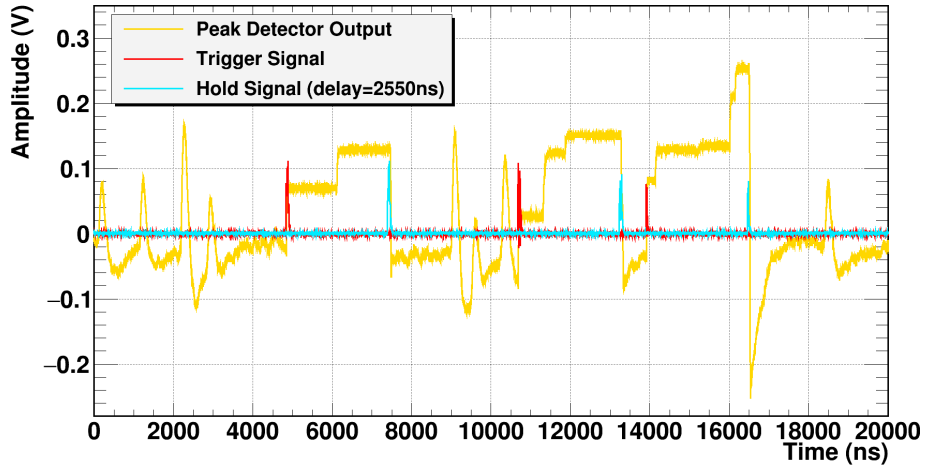

Figure 5. Peak detector analog output with real SiPM pulses in dark condition. The yellow curve represents the peak detector output, while the red and blue curves are the trigger and hold signals, respectively. The delay between trigger and hold signal has been set to 2550 ns. In the peak detector signal, it is evident the detection of several pulses with amplitude higher than 1 pe generated by the cross-talk effect.

5 Dark count spectra

In peak detector working mode, the output is always the highest signal value in the time interval between the trigger and the rising edge of hold signal. The increase of the time interval between the trigger and the hold signal strongly affects therefore the pulsed height distribution. In Fig. 6 it is clearly visible how the number of events accumulated in the first and second peak increases significantly with the hold delay. In Fig. 7 we show the evolution of the dark count spectrum by varying the hold signal delay from 0 to 2550 ns in steps of 10 ns.

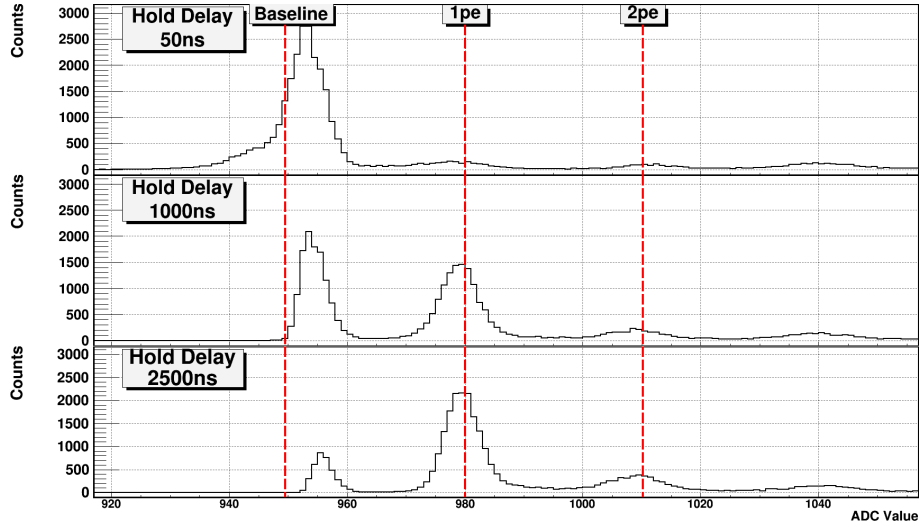

Figure 6. Example of the pulse height distribution of SiPM signals observed with an hold delay of 50 ns, 1000 ns, 2500 ns, in dark condition. The red dashed line indicates the peak positions of the spectra relative to 1pe and 2pe. The 0pe counts are not expected to be gaussian centered on the baseline due the fact that when no SiPM pulses are detected, the peak detector output will depend on the highest noise fluctuaction in the peak detector activation window. Therefore its statistical distribution will be biased toward values higher than the baseline.

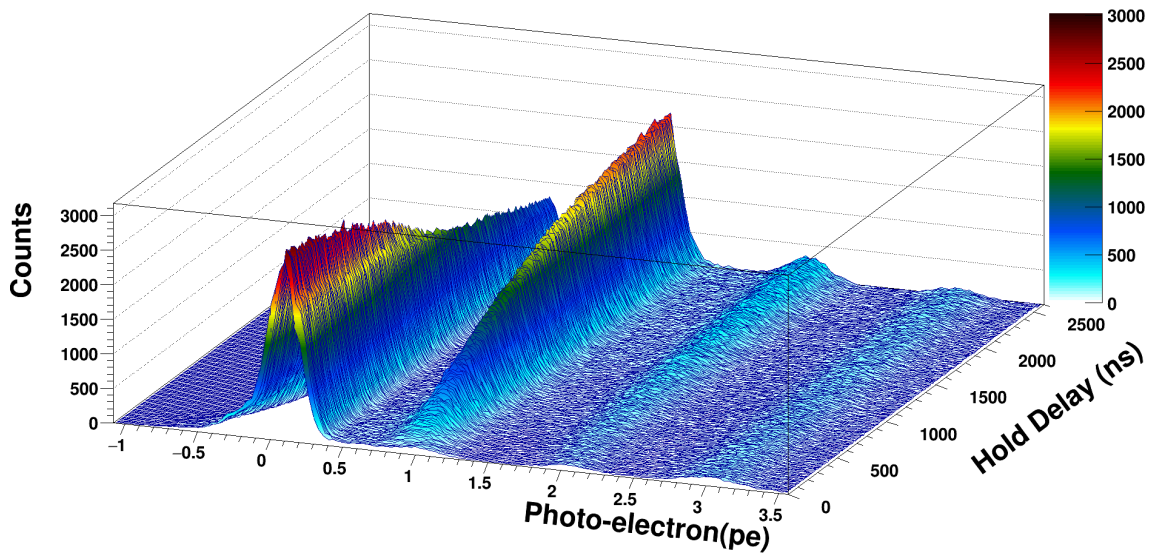

Figure 7. Three-dimensional pulse height spectrum as a function of the hold delay for real SiPM pulses in dark condition. It is evident that, by increasing the hold delay, it is possible to decrease the number of counts in the pedestal peak in favour of the counts at multiple pe values.

6 Evaluation of the pixel gains using the peak detector

The peak detector behaviour shown in the previous section can be exploited for a precise evaluation of the SiPM pixel gain without using any external light source. In fact, just increasing the delay time between the trigger and the hold signal, it is possible to obtain dark count spectra with good statistical significance of the peaks at 1pe, 2pe, etc. To check the validity of this method, we accumulated the dark pulse height spectra relative to an hold delay of 2550 ns. The dark spectrum is analysed with a multiple peaks Gaussian fit. The ADC values of the peaks are then plotted as a function of the number of photo-electrons and fitted (with the exclusion of the baseline peak) to a straight line. The slope of the resulting fit line gives the pixel gains, while its extrapolation at 0pe provides the true baseline.

As first test for a consistency check, we applied the same method to the spectrum obtained by illuminating the SiPM with a ns pulsed blue-light-emitting diode (LED) setting the hold delay to 90 ns (see Fig. 9).

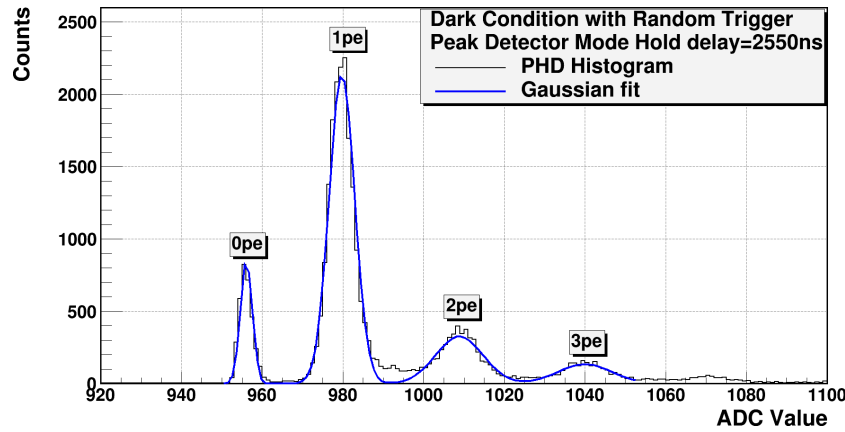

Figure 8. Single photo-electron peak spectrum taken in peak detector mode with a Hold delay time of 2550 ns with SiPM pulses in dark condition. The black curve represents the distribution of the peak detector output and the blue curve shows the corresponding multiple peaks Gaussian fit.

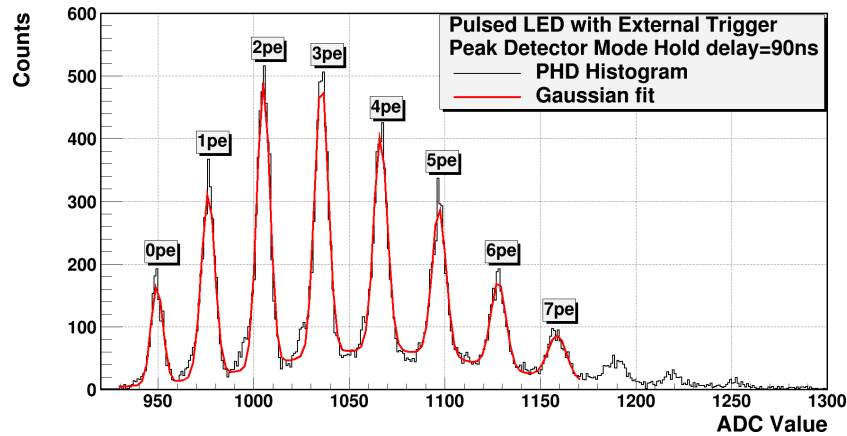

Figure 9. Pulse height spectrum acquired by illuminating the SiPM with a ns pulsed light source. The black curve represents the distribution of the peak detector output and the red curve shows the corresponding multiple peaks Gaussian fit.

As shown in Fig. 10, the pixel gain obtained from the dark counts (29.9 ± 3.4) ADC/pe is in good agreement, within the statistical errors, with the value achieved from the external pulsed light (30.4 ± 0.9) ADC/pe.

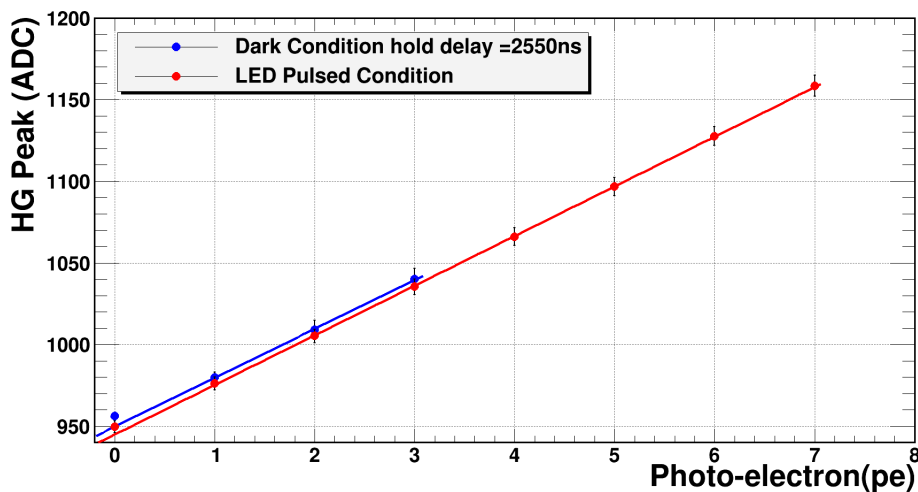

Figure 10. Values in ADC unit of the peaks of the spectrum distribution as a function of the number of photo-electrons, for the case of the spectrum obtained keeping the sensor in dark (blue points) and with the external pulsed light (red points).

Note that the value corresponding to the peak at 0pe, is not considered in the fit since it is, as expected, systematically higher than the baseline due to the positive bias induced by the peak detector working mode when no SiPM pulses are detected. The true baseline can be however easily obtained as the value assumed by the fitting line at 0 pe.

The two methods present different advantages\disadvantages that must be taken into account in designing a calibration system for a given experiment.

The method with the external pulsed light provides rather smaller statistical errors than the "dark method" because more peaks can be produced in the spectra distribution. However, if the scientific instrument has a large dimension, it may be difficult to deliver the ns light pulses to illuminate the detection plane without a significant spreading of the photon pulses along their travel. If excessive, the optical pulses broadening can therefore introduce systematic effects in the pixel gains measured with an external light source. On the contrary, the dark pulses generated by the cross-talk effect have the same temporal structure for all pixels and, therefore, the method allows us to measure the pixel gains with a lower level of systematic. An artificial pulsed light source able to provide large illumination levels is clearly necessary to extend the gain measurement, from a few pe, up to the full working range of the instrument and to verify the response linearity.

7 Conclusion

We have shown that by simply increasing the activation time of peak detector working mode it is possible to obtain dark count spectra that allow calibrating the SiPM gain without an external light source. This calibration method is particularly useful for all experiments where the use of an external calibration light to illuminate the SiPM is not simple due to, e.g. the extended dimensions of the SiPM covered area.

In the context of Astri-Horn the proposed method will be used to complement and cross-check the results obtained with a pulsed light source illuminating the detection plane [11]. Further tests with other types of SiPM pixels will be performed and presented in a future article, where we will describe and verify the validity of the method in a more extended way.

Acknowledgments

This work is supported by the Italian Ministry of Education, University, and Research (MIUR) with funds specifically assigned to the Italian National Institute of Astrophysics (INAF) for the Cherenkov Telescope Array (CTA), and by the Italian Ministry of Economic Development (MISE) within the "Astronomia Industriale" program. We acknowledge support from the Brazilian Funding Agency FAPESP (Grant 2013/10559-5) and from the South African Department of Science and Technology through Funding Agreement 0227/2014 for the South African Gamma-Ray Astronomy Programme.

D.I., A.S., O.C., S.G. and T.M. thank S. Lombardi for his contribution as internal referee of the paper.

References

- [1] Mirzoyan,R., Kosyra,R. and Moser,H.-G., "Light emission in Si avalanches", Nuclear Instruments and Methods in Physics Research Section A 610 (2009) 98-100
[doi: <https://doi.org/10.1016/j.nima.2009.05.081>]
- [2] Fleury, J. et al., "Petiroc and Citiroc : Front-end ASICs for SiPM readout and ToF applications", Journal of Instrumentation, Vol. 9, C01049, (2014)
[doi: <https://doi.org/10.1088/1748-0221/9/01/C01049>]

- [3] Impiombato, D. et al., "Characterization and performance of the ASIC (CITIROC) front-end of the ASTRI camera" Nuclear Instruments and Methods in Physics Research Section A 794 September, (2015), 185
[doi: <https://doi.org/10.1016/j.nima.2015.05.028>]
- [4] Callier, S. et al., "EASIROC, an easy & versatile readout device for SiPM", in proceedings of Technology and Instrumentation in Particle Physics, Chicago, IL, U.S.A., 9-14 June 2011, Phys. Proc. 37 (2012) 1569.
[doi: <https://doi.org/10.1016/j.phpro.2012.02.486>]
- [5] Impiombato, D. et al., on behalf of the ASTRI Collaboration, "Characterization of the front-end EASIROC for readout of SiPM in the ASTRI camera", Procs. SciNeGHE 2012 Workshop, 20-22 June 2012, Lecce, Italy, Nucl. Physics B (Proceedings Supplements), Vol. 239, Pages 254-257, June 2013
[doi: <https://doi.org/10.1016/j.nuclphysbps.2013.05.039>]
- [6] Impiombato, D. et al., on behalf of the ASTRI Collaboration, "Characterization of EASIROC as front-end for the readout of the SiPM at the focal plane of the Cherenkov telescope ASTRI" Nuclear Instruments and Methods in Physics Research Section A , Vol. 729, Pages 484-490, November 2013
[doi: <https://doi.org/10.1016/j.nima.2013.07.029>]
- [7] Marano, D. et al., "PSPICE High-Level Model and Simulations of the EASIROC Analog Front-End", International Journal of Modelling and Simulations 34 (4), 2014
[doi: [10.2316/Journal.205.2014.4.205-6005](https://doi.org/10.2316/Journal.205.2014.4.205-6005)]
- [8] Impiombato, D. et al., on behalf of the ASTRI Collaboration, "Evaluation of the optical cross talk level in the SiPMs adopted in ASTRI SST-2M Cherenkov Camera using EASIROC front-end electronics" Journal of Instrumentation 9 (02), (article id. C02015)
[doi: <https://doi.org/10.1088/1748-0221/9/02/C02015>]
- [9] Pareschi, G., "The ASTRI SST-2M prototype and mini-array for the Cherenkov Telescope Array (CTA)" SPIE Astronomical Telescopes + Instrumentation, Proceedings Volume 9906, Ground-based and Airborne Telescopes VI; 99065T (2016)
[doi: <https://doi.org/10.1117/12.2232275>]
- [10] Scuderi, S., "From the Etna volcano to the Chilean Andes: ASTRI end-to-end telescopes for the Cherenkov Telescope Array" SPIE Astronomical Telescopes + Instrumentation, Proceedings Volume 10700, Ground-based and Airborne Telescopes VII; 107005Z (2018)
[doi: <https://doi.org/10.1117/12.2312453>]
- [11] Catalano, O. et al., "The ASTRI camera for the Cherenkov Telescope Array" SPIE Astronomical Telescopes + Instrumentation, Proceedings Volume 10702, Ground-based and Airborne Instrumentation for Astronomy VII; 1070237 (2018)
[doi: <https://doi.org/10.1117/12.2314984>]