



Publication Year	2010
Acceptance in OA	2023-02-06T10:14:38Z
Title	Marsis radar: Level 2 Processor Requirements
Authors	CARTACCI, MARCO, CICCHETTI, ANDREA, NOSCHESE, RAFFAELLA
Handle	http://hdl.handle.net/20.500.12386/33164



Date 01/09/2010
Issue 1
Revision 0
Page 1 of 22

MARSIS radar: Level 2 Processor Requirements

Issue 3, Rev 0

PREPARED by : Marco Cartacci¹, Andrea Cicchetti¹, Raffaella Noschese¹

CHECKED by : Roberto Orosei²

APPROVED by : Roberto Orosei²

¹INAF-IAPS Via Fosso del Cavaliere 100, 00133, Rome, Italy

²INAF-IRA Via Piero Gobetti, 101, 40129 Bologna, Italy



Date 01/09/2010
Issue 1
Revision 0
Page 2 of 22

1. Introduction	3
2. Level 2 Elements	3
2.1 Data Decompression	3
2.2 Acquisition-Tracking Control Loop	3
2.3 ADC correction	4
2.4 Hardware Calibration.....	4
2.5 Ionospheric Dispersion Correction	5
2.5.1 Contrast Method	5
2.6 Range Compression	6
2.7 Power Control	6
3. Level 2 Input	6
4. Level 2 Output.....	7
4.1 Software output.....	7
4.2 Graphic output.....	10
5. Ionosphere Sounding Data Product.....	11



Date 01/09/2010
Issue 1
Revision 0
Page 3 of 22

1. Introduction

The primary task of Level 2 data processor is the Range Compression of the Marsis collected echoes during the subsurface modes (except for the SS2 Mode) and transmitted to the ground. These data are only compressed in azimuth on board (Doppler Filters output).

Since these data have been distorted by the Ionosphere, we cannot use an ideal reference function (the ideal chirp) for range compression.

Therefore we shall use the Contrast Method to estimate the Ionospheric distortion and to calculate a complex correction to modify the Ideal Reference Function in order to optimize the compressed signal.

Note that the data related to the SS2 Mode will not be processed by the Level 2 processor, because they will be transmitted to the ground already compressed in time and also after a multilooking procedure.

In conclusion the Level 2 processor could elaborate the same data more times, using the information elaborated during the mission on the ionosphere and the instrument. This will signify a progressive improvement of the Level 2 data product.

2. Level 2 Elements

The Level 2 processing can be resumed in seven steps (see Fig. 1):

- Data Decompression
- Acquisition-Tracking Control Loop
- ADC Correction
- Hardware Calibration
- Ionospheric Dispersion Correction (Contrast Method)
- Range Compression
- Power Control

2.1 Data Decompression

First of all the Level 2 processor shall convert the 8 bit data format of the Level 1B in a 32 bit (floating point) data format.

2.2 Acquisition-Tracking Control Loop

In this phase the processor will elaborate all the frames of all the Subsurface Mode (SS1, SS2, SS3, SS4 and SS5) of a selected orbit, to control if the sequence of Acquisition (or Preset Tracking) and Tracking frames are correct or less (in first approximation). For example if there



Date	01/09/2010
Issue	1
Revision	0
Page	4 of 22

is a sequence of two or more Acquisition frames, or the radar return to the Acquisition after only one frame in Tracking, the processor set a dedicated flag of warning to one (see Fig. 2).

2.3 ADC correction

Level 2 processor will be able to reject the low-frequency ripple induced by the ADC up to 100 KHz if this operation has not been performed by the on board processing.

In detail this phase will consist in a filter that will set to zero the first samples (whose number will correspond to the threshold defined above) of each Doppler Filters output.

The threshold value will be stored in the CALIB Directory of the Level 1B.

2.4 Hardware Calibration

The instrument (TX, RX, antennas...) calibration will be performed starting during the cruise, the Commissioning and the operation phases. The mainly output of this activities will be: the amplitude and phase distortion for each bands and for each antennas; an estimations of the system gain and antennas radiation factor and in particularly the position of the Monopole null.

All these data will be contained in the Level 1B.

These information will allow to modify, if necessary, the reference function used for the Ionospheric Correction and the Range Compression.

In fact the chirp is distorted by the matching network during transmission and receiving phase.

A possible solution is the use of a sets of functions dedicated to this aim.

This operation shall be performed in frequency with the use of different correction function (called Calibration Function) in order to select the function that optimize the reference function.

This phase shall be done during the Contrast Method loop.

In detail the Contrast will be repeated for each calibration function of the defined set available for the band of interest (see Fig. 3).

The best calibration function will correspond to the minimum value of signal energy. The calibration function selected in this way shall be used also to correct the reference function used for the Range Compression phase.

It is worth noting that these calibration function of 512 samples will be in numeric form and will be stored in the CALIB Directory of the Level 1B.

The Hardware Calibration phase shall be repeated in successive periods of the Marsis mission, in order to match the modification occurred to the matching network distortion due to the age of the electronic components.

In conclusion, the use of the Contrast Method in the Hardware Calibration Phase, will lead to the necessity to save in a local memory all the parameters, and in particular the function necessary to correct the effect of the ionosphere, estimated for each calibration function. Of course only the data corresponding to the best calibration function shall be stored in the Level 2 data product (see section 4.1).



2.5 Ionospheric Dispersion Correction

As it is well known if a radio-frequency pulse, of frequency f , propagates through a section a ionized medium with plasma frequency f_p , it will be subjected to an extra-phase shift with respect to the free-space propagation, causing a distortion of the range compressed signal. In order to maximize the penetration depth, MARSIS will use low transmission frequencies, as close as possible to the plasma frequency. Therefore, the chirp code transmitted by MARSIS will suffer a phase distortion that, if not compensated, will result in an unacceptable loss of performance on the compressed waveform (see Fig. 4).

For this aim two compensation procedures are available:

2.5.1 Contrast Method

The starting point of this method is the use of the “gamma” model in order to characterize the distribution of the plasma frequency vs. height and to quantify the amount of distortion due to the ionosphere propagation.

$$f_p(z) = f_{p\text{-max}} \frac{z - h_0}{b} e^{1 - \frac{z-h_0}{b}} \delta_{-1}(z - h_0)$$

Where $f_{p\text{-max}}$ is the maximum plasma frequency, b is the shape factor and h_0 is the beginning of the ionosphere layer. We can remember that the phase distortion induced by plasma layer of thickness L as a function of the frequency f depends on the profile of the plasma frequency and can be expressed as:

$$\Delta\phi_{GAMMA}(f, b, f_{P,MAX}) = \frac{4\pi}{c} f \int_0^L \left[\sqrt{1 - \left(\frac{f_p(z)}{f} \right)^2} - 1 \right] dz$$

In order to reduce the estimation complexity has been introduced an alternative simplified model (Uniform model) and his development in series (for more detail see [1]).

$$\Delta\phi_{EQ}(f) = \frac{4\pi L_{EQ}}{c} f \left(\sqrt{1 - \left(\frac{f_{p,eq}}{f} \right)^2} - 1 \right) = 2\pi\tau_0 \left(\sqrt{f^2 - f_{p,eq}^2} - f \right)$$

$$\Delta\phi_{EQ}(f) = 2\pi\tau_0 \left(\sqrt{f^2 - f_{p,eq}^2} - f \right) \cong a_0 + a_1(f - f_0) + a_2(f - f_0)^2 + a_3(f - f_0)^3 + a_4(f - f_0)^4 + \dots$$



Date 01/09/2010
Issue 1
Revision 0
Page 6 of 22

Where the ionosphere equivalent thickness is fixed to an average value $L_{EQ}=L_m$ (80 km) ($\tau_0=533 \mu\text{sec}$).

In particular the estimation procedure is reduced to the estimation of the quadratic term a_2 (which correspond to the chirp slope). In addition the cubic and fourth term of frequency series development of ionosphere model are estimated. The last version of Contrast flow-chart with the related tables is in appendix 1.

2.6 Range Compression

In this phase the ideal reference function modified by the correction term, obtained by the Ionospheric Correction phase, will be used for the range compression of all the Doppler Filters output.

In particular there are two ways to obtain the range compression:

- The classical matched filter
- The inverse filter

In both cases the signal will be weighed with the Hanning function to reduce the side lobe level:

- In time after compression for the matched filter
- In frequency before compression in the case of inverse filter (in this case it is the reference function to be weighed).

2.7 Power Control

The task of this step will be to control if the power of the signal of the Doppler Filter 0, after range compression, it is subject to strange variation considering successive frames. If this variation occurs another flag of warning will be set to one (see fig. 5).

The threshold value will be stored in the CALIB Directory of the Level 1B.

This phase shall be done also for the SS2 mode.

3. Level 2 Input

The main source of inputs for the Level 2 is the Level 1B, that is in PDS format.

The Level 1B contain all the data produced by the Marsis instrument (Subsurface Data, Active Ionosphere Sounding Data, Passive Ionosphere Sounding Data, Auxiliary Data...), reconstructed from the scientific telemetry. Moreover there are many other spacecraft telemetry relevant for calibration and processing, as spacecraft position, radial and tangential velocity, altitude... (Geometry Data).

Not all these information are useful for Level 2.

Then in this section we will consider only the data necessary for Level 2 processor.

The Level 1B structure will be as illustrated in the fig. 6.

The Data directory will be organized in set of ten orbits, while the subdirectories named EDR_XXXX (Experiment Data Record) will contain the instrument data sorted by operative mode for each orbit.



Date 01/09/2010
Issue 1
Revision 0
Page 7 of 22

Then for each Operative Mode there will be the collection, for different status (acquisition or tracking), of the relative frames in a dedicated file.

The structure of these files is described in fig.7, for the frames collected during the subsurface modes.

Therefore, according to the operative modes used in the timeline, a different amount of data will be transmitted from Marsis and then the information of the orbit subdirectory will vary.

It is worth noting that, according with the Operative Mode SS1, SS3, SS4 and SS5, the scientific information will consist in a variable number of Doppler Filter that represent the signal after the on board azimuth compression. As it is show in fig. 7 the signal will be given in frequency and will be represented by 512 samples for the Real and the Imaginary part, in a 8 bit format (compressed).

Only exception is the Operative Mode SS2, where the signal is transmitted to the ground already compressed in time and also after a multilooking processing. In this case the 512 samples represent the power of the signals obtained with two different frequencies.

In conclusion as described in fig. 7 and 8 the radar signals of a single frame will be stored in the files named Marsis Data FRM with the correspondent Ancillary and Geometry data.

- The Marsis Ancillary Data File shall contain characteristic parameters used and/or estimated on board during the operational activity of Marsis (Acquisition Phase, Tracking Phase, Individual Echoes, Active Ionosphere Sounding, Receive Only and Calibration).
- The Geometry Data File shall contain orbital parameters (tangential velocity, radial velocity, altitude...) coming from MEX.
- The PIS data files shall contain the information collected during the Passive Ionosphere Sounding mode.

Furthermore, for each EDR_XXXX stored in the DATA directory there is an equivalent EDR_XXXX in the CALIB directory that shall contain a LOG file with a set of parameters estimated on board during, for instance, the Contrast Method or the FSR Method. These LOG file shall contain also the a set of Reference Functions calibrated during the Calibration Phase and the information necessary to the ADC Correction and the HW Calibration phases).

4. Level 2 Output

The Level 2 processing will produce two type of output:

- Software output: this is the main data product of Level 2 and will be stored for the following phases of signal elaboration as Level 3 (data inversion);
- Graphic output: the task of this interface will be to control and validate the Level 2 processing.

4.1 Software output

The Level 2 software output is in PDS format and maintain the organization of the Level 1B as illustrated in the following scheme:

As it is well known the primary task of Level 2 data processor is the Range Compression of the Marsis collected echoes during the subsurface modes (except for the SS2 Mode).



Date 01/09/2010
Issue 1
Revision 0
Page 8 of 22

Since these data have been distorted by the Ionosphere the Level 2 processor shall use the Contrast Method to estimate the Ionospheric distortion and to calculate a complex correction to modify the Ideal Reference Function in order to optimize the signal compression.

This means that each file of raw data (the echoes compressed in azimuth) will be replaced with a file containing the same data compressed in range too. Obviously, the subdirectories will change the names, in fact the EDR_XXXX will be replaced with RDR_XXXX.

The Level 2 will be in PDS format and will maintain the organization of the Level 1B as illustrated in the fig. 8, moreover the Level 2 processor shall convert the 8 bit data format of the Level 1B in a 32 bit (floating point) data format.

The only change in the Level 1B structure is the introduction of all the information about the Level 2 steps in the LOG file.

It is worth noting that, even if the Level 1B data shall be given in their complex (I and Q) components, the data product of the Level 2 shall be represent the signal in module and phase (see fig. 9).

Note that even if the raw data provided by Level 1B are in frequency, the output of Level 2 is in time.

The last thing to note is that, as anticipated in the previous section, the signals collected during the Operative Mode SS2 has been already compressed in range, then the only variation about these information is related to the passage from the original 8 bit format to the new 32 bit format.

Compression Data (TBC)			
Symbol	Value	Units	Notes
W	1→ Acquisition_Tracking transition not normal 0→ Acquisition - Tracking transition normal	-	General information about Range Compression
PW	1→ Power Control Warning 0→ Power Control Normal	--	
X	Threshold for Power Control	dB	
ADC_Thresh	ADC Correction Threshold	KHz	
Cal_Fun	Calibration Function selected	512 samples	
CM	1→ Contrast Method 0→ FSR Method	-	
FLA	1→ first loop after Acquisition or Preset Tracking 0→ Tracking Phase	-	
IF	1→ Inverse Filter 0→ Matched Filter	-	
f ₀	-	MHz	
f _d	-	MHz	
OPT	1→compensation with optimized formulas 0→compensation with standard formulas	-	Information about Contrast Method
A ₄	1→compensation up to term a ₄ 0→compensation up to term a ₃	-	
a _{2_start}	-	rad/Hz ²	
τ ₀	-	μsec	
Dim_win	-	μsec	
offset	-	μsec	
\hat{a}_2	-	rad/Hz ²	
\hat{a}_3	-	rad/Hz ²	



Date 01/09/2010
Issue 1
Revision 0
Page 9 of 22

\hat{a}_4	—	rad/Hz ²	
b_{opt}	—		
f_{01}	—	MHz	
τ_{01}	—	μ sec	
α	—	—	
β	—	—	
Thresh	—	—	Information about FSR Method
Thresh_1	—	—	
Thresh_2	—	—	
δt	—	—	
S_f	—	—	

Table



4.2 Graphic output

Even if the Level 2 processor will be fully automatic, a graphic interface will allow to monitor the results obtained. In detail this graphic facility will be able to show the signal after the range compression, for one or more Doppler Filter output and for one or more frames.

However the most important goal of this interface will be to control if the Ionosphere Correction work in the right way.

In particular shall be important to verify if the value of a_2 (and then a_3 and a_4) estimated by the Contrast Method is wrong.

For example we can see that in Fig. 10 the Contrast has worked well, while in Fig. 11 is evident that the value of a_2 estimated is wrong.

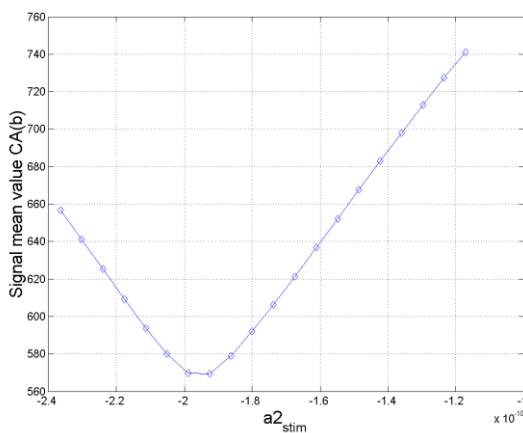

Fig. 10

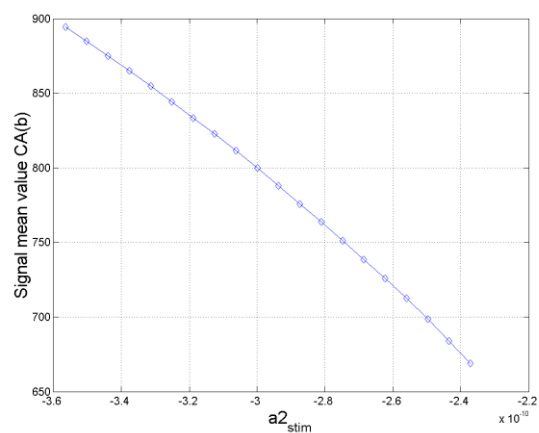

Fig. 11

In fact if the minimum of $CA(b)$, that represents the signal energy, is on the borders of the interval of investigation, surely the corresponding value of a_2 is not right.

Of course we cannot control the Contrast Method results for every frame but only when the parameter ' b_{opt} ', stored in the Compression Data file, assume some values (1, 2, 19, 20).

In this case the Level 2 processor will send a warning to the operator automatically.

Another situation to monitor occur when, during the FSR method, the square modulus of the signal after range compression doesn't overcome none of the two thresholds (see App. 2 pag. 31).

In that case, in fact, the ionospheric correction term will be the same estimated in the previous frame and the possibility of a wrong Range Compression phase is high.

For this reason the Level 2 processor will send a warning to the operator automatically when the term ' S_f ' is equal to zero.

In conclusion the options for the graphic interface will be as follows:



- The plot of the behaviour of CA(b) vs. a_2 (estimated) during the Contrast Method, with the indication of the orbit, the operative mode, the frequency, the S/C height, the frame and also the Compression Data parameters (see Tab. 1). This plot will be available on request or in consequence of a warning. Note that there could be two plots according with the operative mode selected.
- The plot of the Doppler Filter 0 output after the range compression during the Ionospheric Correction loop, with the indication of the orbit, the operative mode, the frequency, the S/C height, the frame and also the Compression Data parameters (see Tab. 1). This plot will be available on request or in consequence of a warning ($b_{opt} = 1,2,19,20$ or $S_f = 0$). Note that there could be two plots according with the operative mode selected.
- The plots of all the Doppler Filters output (all frequencies in use, Dipole and Monopole) after range compression. The graphic interface will show all the parameters listed in the previous points with the indication of the filter and the antenna. These plots will be available only on request by the operator.

All the plots regarding the signal after range compression will represent his square module. For the sake of simplicity, in Table 1 and in Table 2 there are all the parameters that will be shown by the graphic interface.

offset			
Symbol	Value	Units	Notes
ON	___	___	Orbit Number
OPM	1,3,4,5	___	Operative Mode
H	___	Km	S/C height
FRN	___	___	Frame Number
DFN	-1,-2,0,1,2	___	Doppler Filter Number
AN	1,0	___	Antenna: AN = 1 → Dipole AN = 0 → Monopole

Tab. 2

Now all the graphical output will not be saved or stored in any memory.

5. Ionosphere Sounding Data Product

According to the agreement between the University of Iowa and the Istituto Nazionale di Astrofisica (INAF), the Level 2 Ionosphere Sounding Data product will be furnished by Iowa. In detail:



Date 10/01/2023
Issue 1
Revision 0
Page 12 of 22

The Ionospheric Sounding data products that will be generated by Iowa are the following:

1. Passive Ionospheric Sounding (PIS)
 - Calibrated E-Field values *Level 2 (standard)*
 - Frequency/Time spectrograms *Level 2 (standard)*
 - Values derived from features (f_p) *Higher level*
 - Calculated values (N_e , etc.) *Higher level*

2. Active Ionospheric Sounding
 - Calibrated E-Field values *Level 2 (standard)*
 - Ionograms time delay vs. frequency) *Level 2 (standard)*
 - Frequency/Time spectrograms *Level 2 (standard)*
 - Values derived from features (f_p , $t_{\text{delay}}(f)$) *Higher level*
 - Calculated values (N_e , scale height (H), etc.) *Higher level*

The data product will be organized in binary files.

In conclusion the processed Level 2 and higher-level Ionospheric Data files elaborated by Iowa, will be directly store in the ESA PDS node.

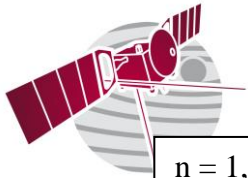

Date 10/01/2023
Issue 1
Revision 0
14 d

ACQUISITION-TRACKING CONTROL LOOP

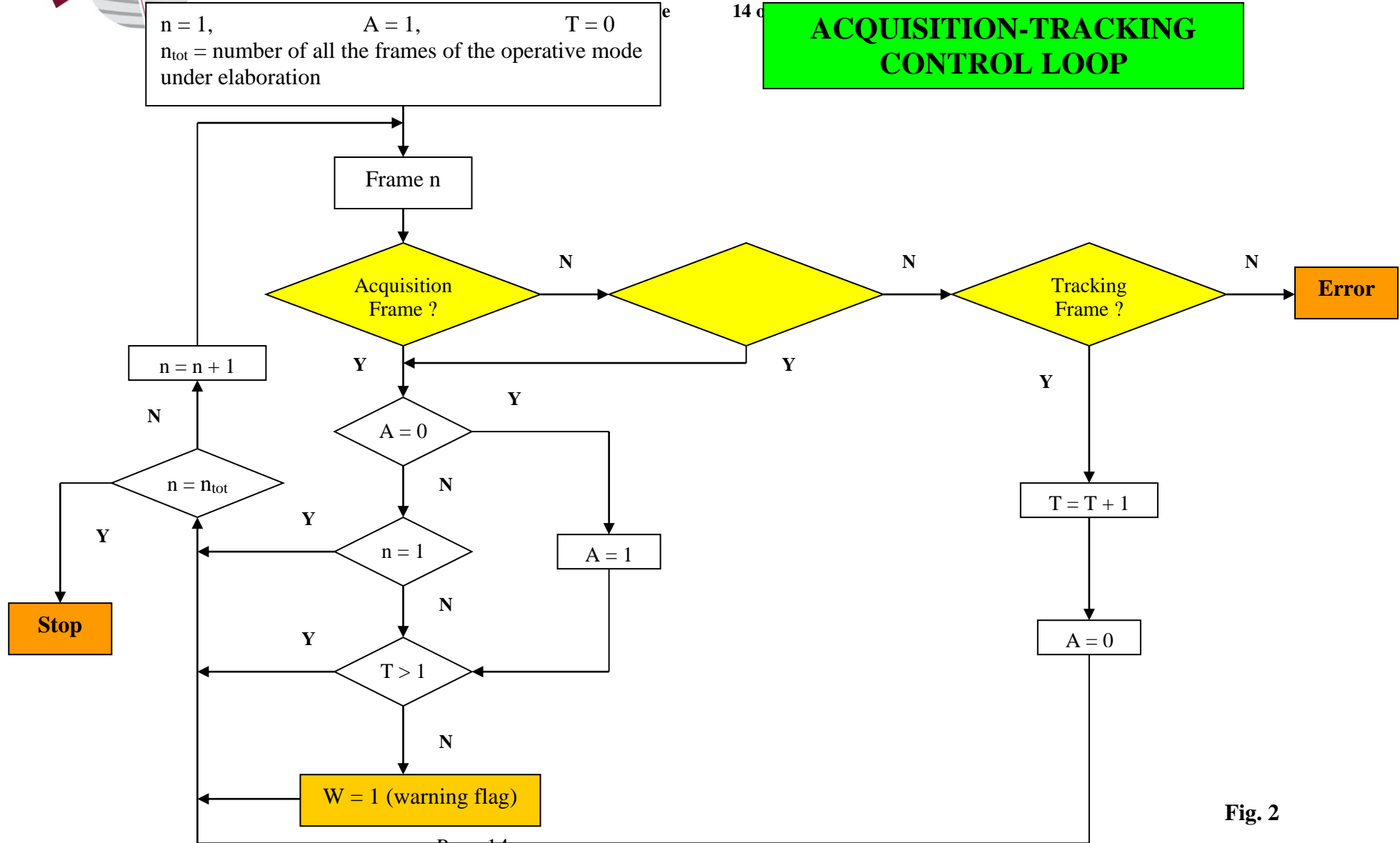

Fig. 2



HARDWARE CALIBRATION PHASE

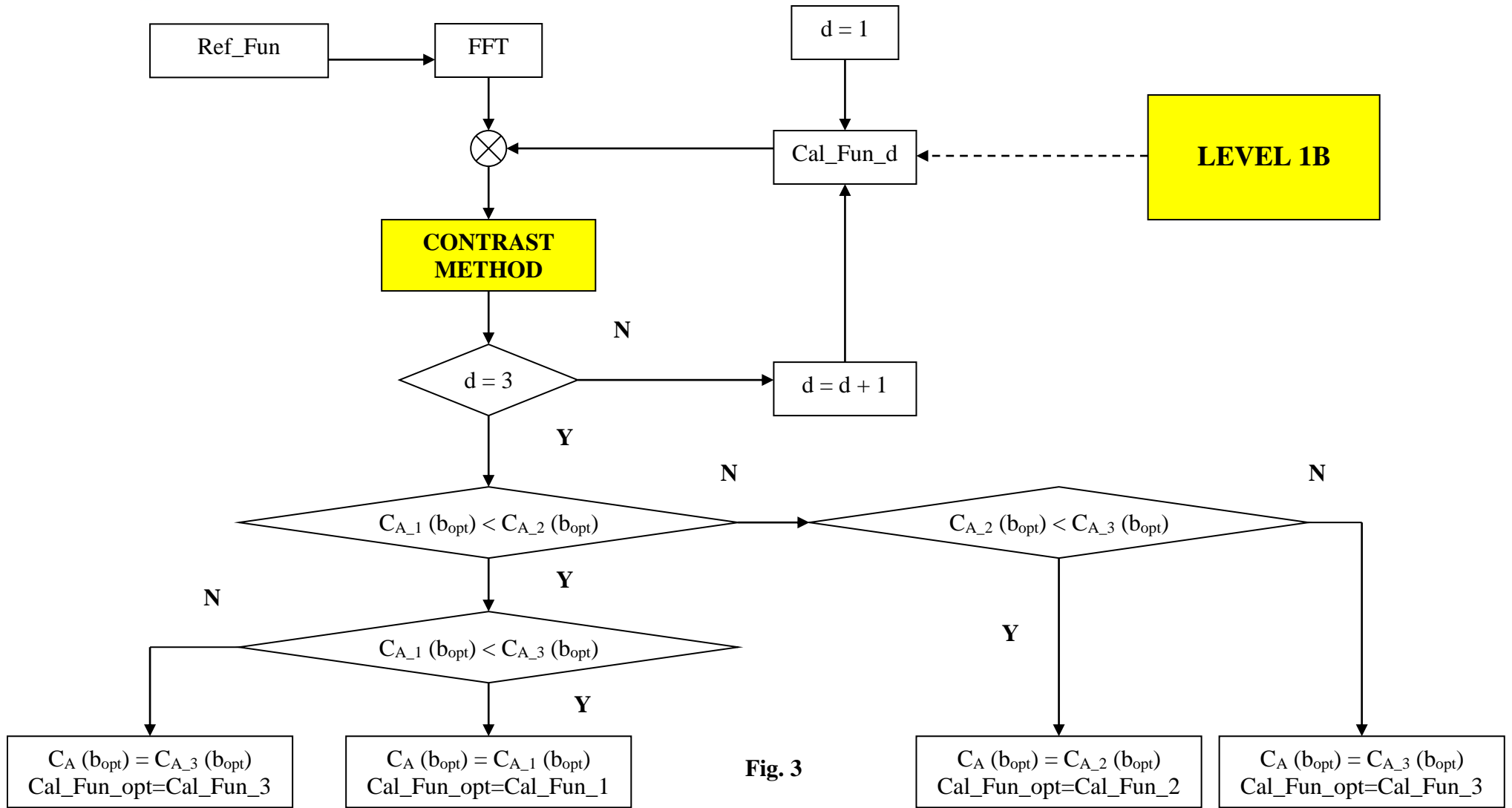

Fig. 3



Date 10/01/2023
Issue 1
Revision 0
Page 16 of 22

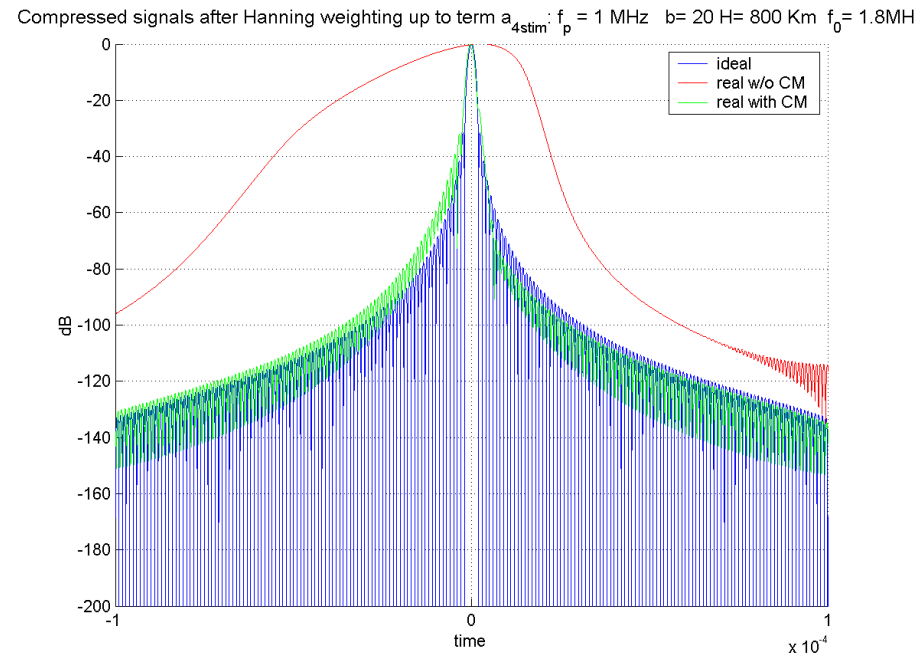

Fig. 4 : the blue line correspond to the ideal chirp compressed in range; the red line correspond to the real chirp compressed in range with the effect of the Ionosphere Distortion without compensation; the green line correspond to the real chirp compressed in range with the effect of the Ionosphere Distortion compensated by the Contrast Method.

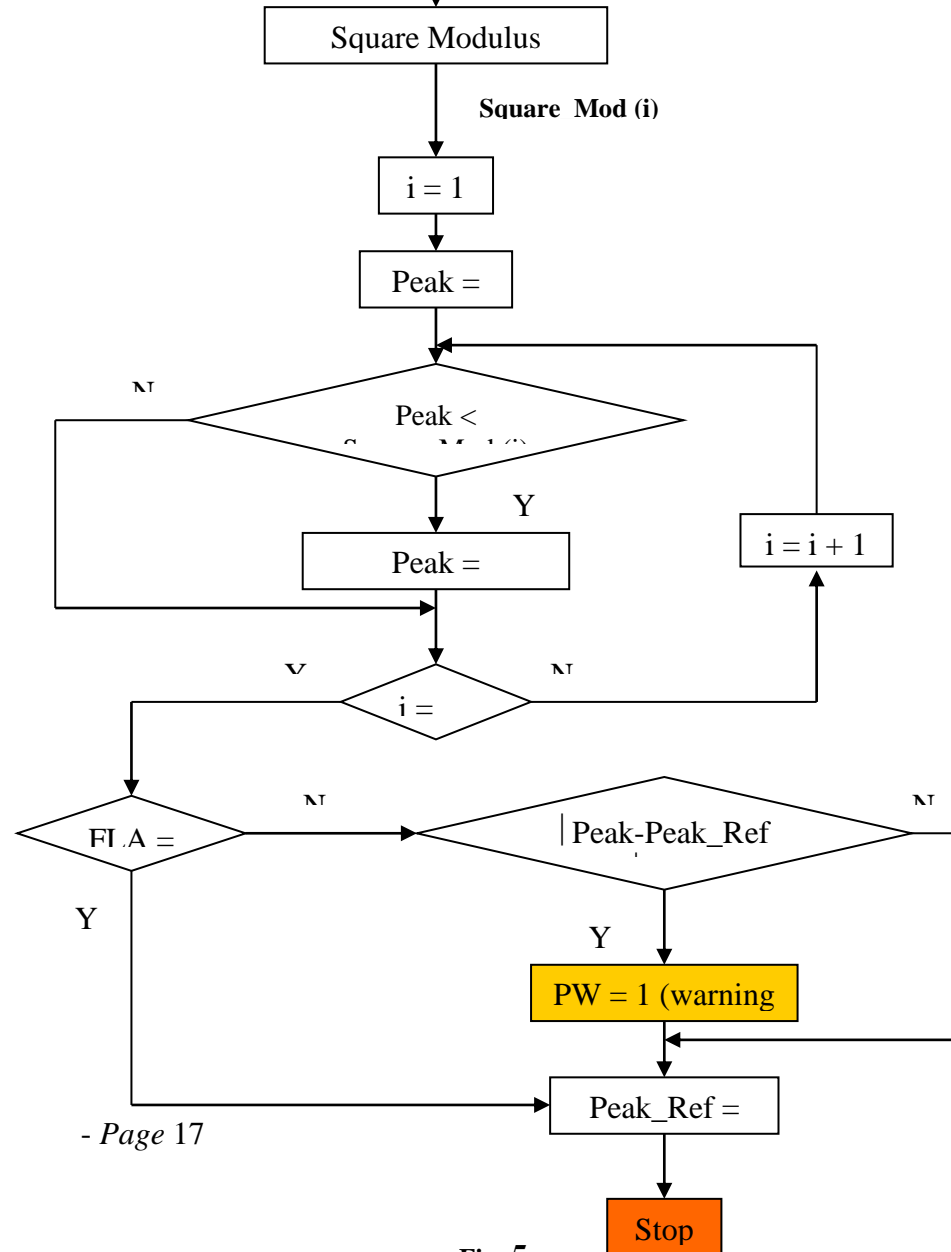

Fig. 5

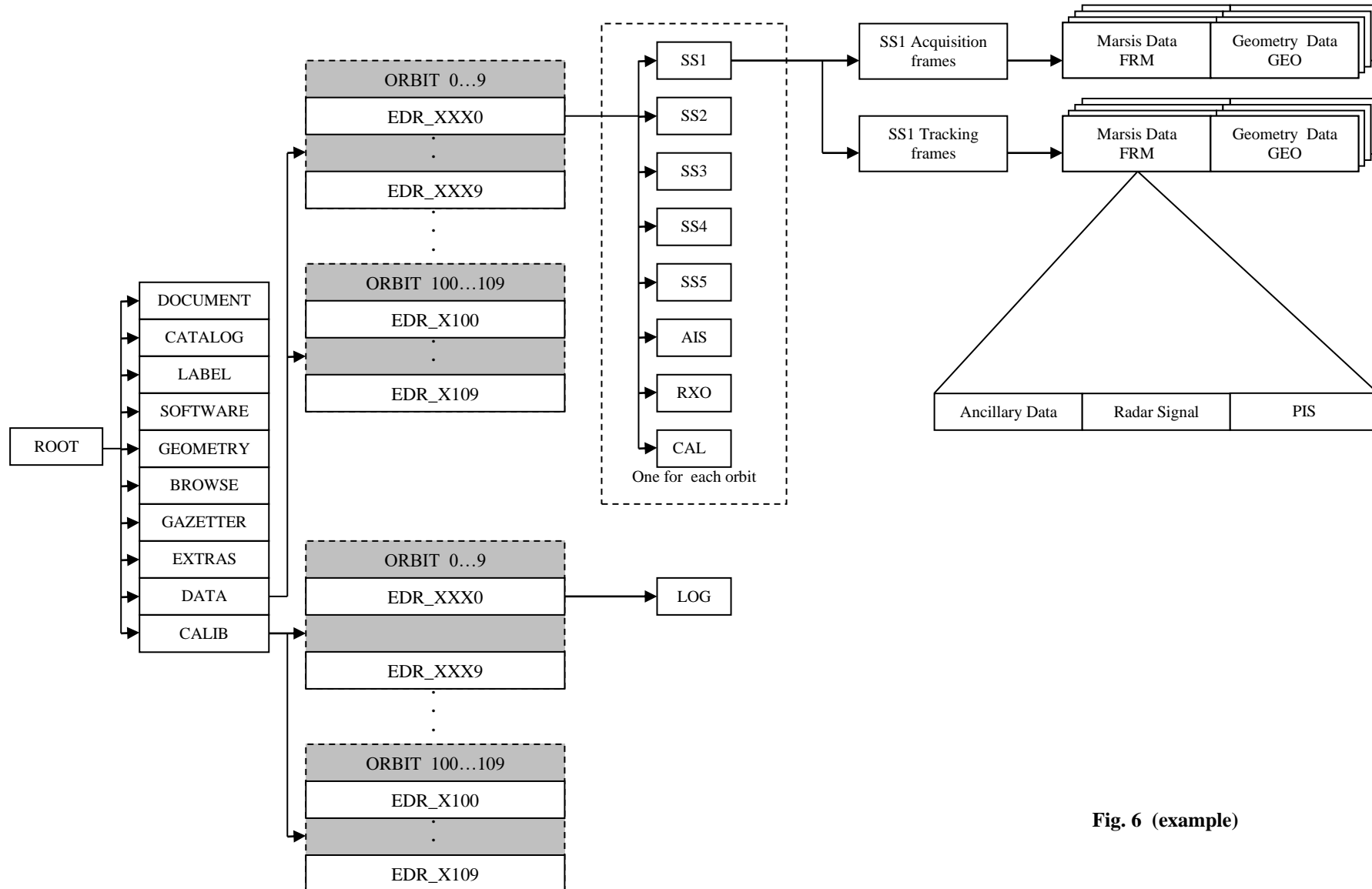

Fig. 6 (example)



Date 10/01/2023
 Issue 1
 Revision 0

RADAR SIGNAL (SS1, SS3, SS4, SS5)							
DIPOLE F1 Doppler Filters (-2, -1, 0, 1, 2)		DIPOLE F2 Doppler Filters (-2, -1, 0, 1, 2)		MONOPOLE F1 Doppler Filters (-2, -1, 0, 1, 2)		MONOPOLE F2 Doppler Filters (-2, -1, 0, 1, 2)	
512 samples (8 bit/sa RE)	512 samples (8 bit/sa IM)	512 samples (8 bit/sa RE)	512 samples (8 bit/sa IM)	512 samples (8 bit/sa RE)	512 samples (8 bit/sa IM)	512 samples (8 bit/sa RE)	512 samples (8 bit/sa IM)

MARSIS DATA FRAME (SS1 MODE)							
DF 0 Dipole f_{01}		DF 0 Dipole f_{02}		DF 0 Monopole f_{01}		DF 0 Monopole f_{02}	
RE	IM	RE	IM	RE	IM	RE	IM

MARSIS DATA FRAME (SS2 MODE)			
Dipole f_{01}		Dipole f_{02}	
512 samples (8 bit/sa POWER)		512 samples (8 bit/sa POWER)	

MARSIS DATA FRAME (SS3 MODE)											
DF -1 Dipole f_{01}		DF 0 Dipole f_{01}		DF +1 Dipole f_{01}		DF -1 Dipole f_{02}		DF 0 Dipole f_{02}		DF +1 Dipole f_{02}	
RE	IM	RE	IM	RE	IM	RE	IM	RE	IM	RE	IM

MARSIS DATA FRAME (SS4 MODE)																					
DF -2 Dipole f_0		DF -1 Dipole f_0		DF 0 Dipole f_0		DF +1 Dipole f_0		DF +2 Dipole f_0		DF -2 Monopole f_0		DF -1 Monopole f_0		DF 0 Monopole f_0		DF +1 Monopole f_0		DF +2 Monopole f_0			
RE	IM	RE	IM	RE	IM	RE	IM	RE	IM	RE	IM	RE	IM	RE	IM	RE	IM	RE	IM	RE	IM

MARSIS DATA FRAME (SS5 MODE)											
DF -1 Dipole f_0		DF 0 Dipole f_0		DF +1 Dipole f_0		DF -1 Monopole f_0		DF 0 Monopole f_0		DF +1 Monopole f_0	
RE	IM	RE	IM	RE	IM	RE	IM	RE	IM	RE	IM

Fig. 7

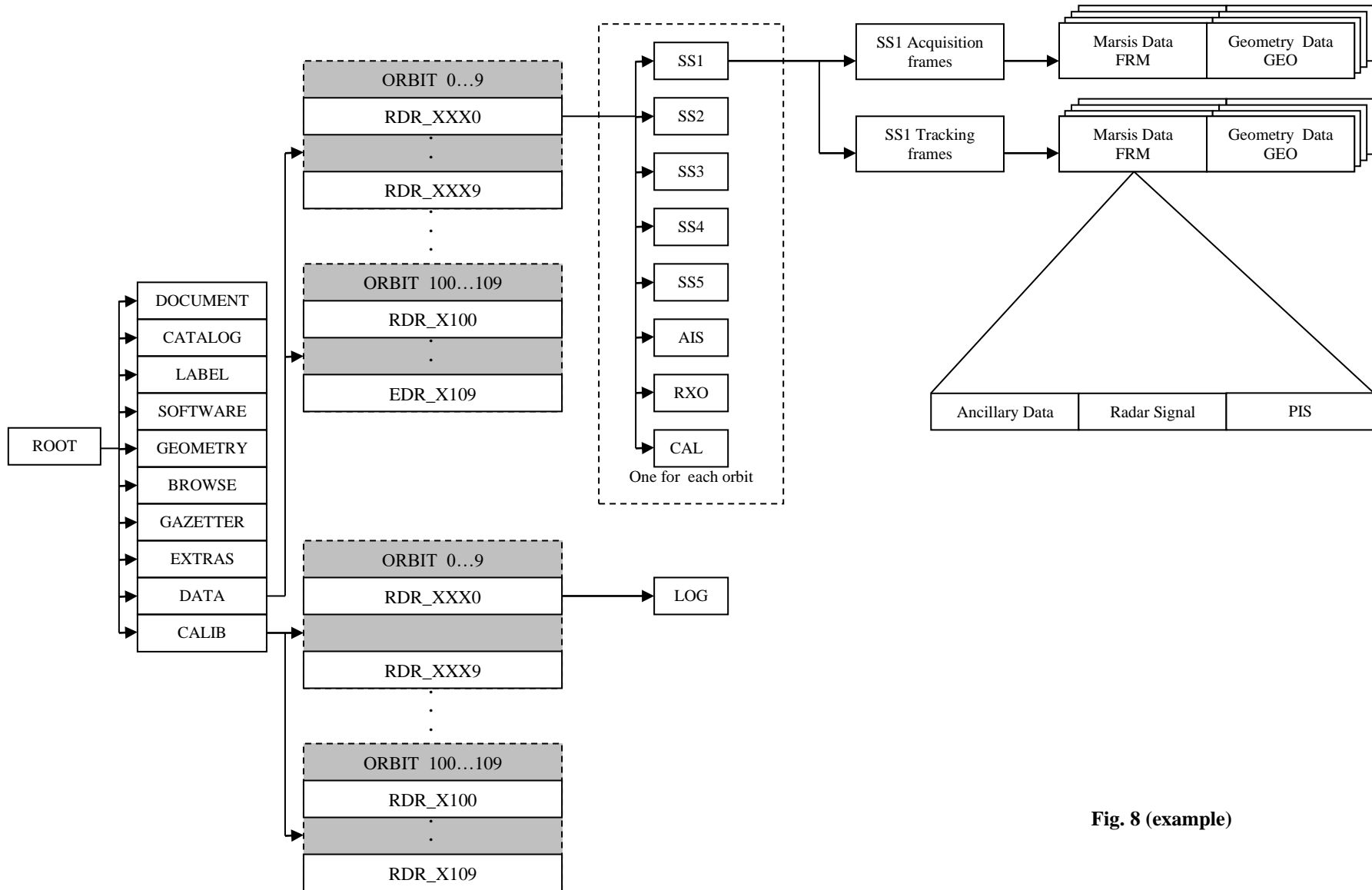

Fig. 8 (example)



Date 10/01/2023
 Issue 1
 Revision 0

RADAR SIGNAL (SS1, SS3, SS4, SS5)							
DIPOLE F1 Doppler Filters (-2, -1, 0, 1, 2)		DIPOLE F2 Doppler Filters (-2, -1, 0, 1, 2)		MONOPOLE F1 Doppler Filters (-2, -1, 0, 1, 2)		MONOPOLE F2 Doppler Filters (-2, -1, 0, 1, 2)	
512 samples (32 bit/sa Module)	512 samples (32 bit/sa Phase)	512 samples (32 bit/sa Module)	512 samples (32 bit/sa Phase)	512 samples (32 bit/sa Module)	512 samples (32 bit/sa Phase)	512 samples (32 bit/sa Module)	512 samples (32 bit/sa Phase)

MARSIS DATA FRAME (SS1 MODE)							
DF 0 Dipole f_{01}		DF 0 Dipole f_{02}		DF 0 Monopole f_{01}		DF 0 Monopole f_{02}	
Mo	Ph	Mo	Ph	Mo	Ph	Mo	Ph

MARSIS DATA FRAME (SS2 MODE)			
Dipole f_{01}		Dipole f_{02}	
512 samples (8 bit/sa POWER)		512 samples (8 bit/sa POWER)	

MARSIS DATA FRAME (SS3 MODE)											
DF -1 Dipole f_{01}		DF 0 Dipole f_{01}		DF +1 Dipole f_{01}		DF -1 Dipole f_{02}		DF 0 Dipole f_{02}		DF +1 Dipole f_{02}	
Mo	Ph	Mo	Ph	Mo	Ph	Mo	Ph	Mo	Ph	Mo	Ph

MARSIS DATA FRAME (SS4 MODE)																			
DF -2 Dipole f_0		DF -1 Dipole f_0		DF 0 Dipole f_0		DF +1 Dipole f_0		DF +2 Dipole f_0		DF -2 Monopole f_0		DF -1 Monopole f_0		DF 0 Monopole f_0		DF +1 Monopole f_0		DF +2 Monopole f_0	
Mo	Ph	Mo	Ph	Mo	Ph	Mo	Ph	Mo	Ph	Mo	Ph	Mo	Ph	Mo	Ph	Mo	Ph	Mo	Ph

MARSIS DATA FRAME (SS5 MODE)											
DF -1 Dipole f_0		DF 0 Dipole f_0		DF +1 Dipole f_0		DF -1 Monopole f_0		DF 0 Monopole f_0		DF +1 Monopole f_0	
Mo	Ph	Mo	Ph	Mo	Ph	Mo	Ph	Mo	Ph	Mo	Ph

Fig. 9



Date 10/01/2023
Issue 1
Revision 0
Page 22 of 22