



Publication Year	2015
Acceptance in OA	2020-04-10T12:59:25Z
Title	Signal compensation in CZT detectors grown by the Vertical Bridgman method using a twin-shaping filter technique
Authors	AURICCHIO, NATALIA, SCHIAVONE, FILOMENA, CAROLI, EZIO, BASILI, ANGELO, STEPHEN, JOHN BUCHAN, Zappettini, A.
Publisher's version (DOI)	10.1109/NSSMIC.2015.7582271
Handle	http://hdl.handle.net/20.500.12386/23986
Serie	PROCEEDINGS..IEEE NUCLEAR SCIENCE SYMPOSIUM AND MEDICAL IMAGING CONFERENCE

Signal Compensation in CZT Detectors Grown by the Vertical Bridgman Method Using a Twin-Shaping Filter Technique

N. Auricchio, F. Schiavone, E. Caroli, A. Basili, John B. Stephen and A. Zappettini

Abstract– CdTe/CZT is now a material consolidated for the detectors realization operating at room temperature, which find a large variety of applications in astrophysics, medical imaging and security.

An Italian collaboration, involving the CNR/IMEM and INAF/IASF institutes, was born several years ago with the aim to develop a national capability to produce CZT detectors starting from the material growth to the final detection device.

The collection efficiency of the charge carriers affects some important features of these detectors, such as the pulse height, energy resolution, photoppeak efficiency. In fact the low mobility of the charge carriers (particularly the holes) and trapping/detrapping phenomena can degrade the CdTe/CZT detector response, depending on the distance between the charge formation position and the collecting electrodes.

Two kinds of techniques can be used to improve both the collection efficiency and the energy resolution, based on the optimization of the electrode geometry and/or signal compensation methods.

We have implemented a biparametric method that uses a twin pulse shaping active filter to analyze the same signal from the detector: one “*slow*”, which is proportional to the energy of the incident photon, and one “*fast*”, which depends on the position of the interaction with respect to the collecting electrode.

We present this biparametric technique applied on planar CZT detectors grown by the Vertical Bridgman method at CNR/IMEM (Parma), the experimental results obtained as a function of the bias voltage, photon energy, shaping time pairs and the compensated spectra.

I. INTRODUCTION

CdZnTe is a semiconductor material with a high atomic number and high density well suited for realizing efficient and compact room temperature hard- X and γ -ray detectors covering the energy range from a few keV to the MeV region. The fields of application of these detectors are various, such as astrophysics, nuclear medicine and material safeguards.

The spectroscopic performance in terms of energy resolution depends strongly on the detector geometry and on the quality of the semiconductor material: the detector capacitance and the leakage current produced at room temperature by the sensor contribute to the total noise of the system. The trapping centers in the semiconductor, in addition

to these factors, produce a loss in charge collection efficiency because of the low mobility of the charge carriers (particularly the holes) degrading the CdZnTe detectors response as it depends on the distance between the charge formation position and the collecting electrodes.

The deterioration of the spectroscopic performances can be reduced by both using hardware (HW) and software (SW) techniques. The bi-parametric method described is based on a hybrid HW and SW technique by utilizing a double pulse shaping active filter in order to analyze the detector signals. Using this method we can have an indirect measurement of the interaction position of an incident photon in the detector active volume.

An Italian collaboration, involving the CNR/IMEM and the INAF/IASF institutes, was born some years ago, in 2005 with the aim to develop a national capability to produce CZT detectors starting from the material growth to the final detection device.

We present the bi-parametric distributions obtained with the application of this technique on CdZnTe detectors grown by the standard vertical Bridgman method by CNR/IMEM as a function of the shaping time pair values, for different primary photon energies and bias voltages. The detector performances have been evaluated at several energies with calibration radioactive sources and the charge transport properties have been studied by mobility-lifetime product measurements. We report the corrected maps and compensated spectra obtained by a preliminary analysis.

II. PRINCIPLE OF THE TWIN-SHAPING TIME METHOD

The twin-shaping time method here described can be considered as a particular case of the rise time technique based on the correlation between the rise time of a signal from the detector and the loss in its pulse height because of the incomplete charge collection. The rise time technique is usually applied to improve the performance of planar semiconductor detectors.

The signal from CSP (charge sensitive preamplifier) coupled with the detector is shaped by two parallel amplifiers with different shaping time constants: one “fast” and one “slow”. The “slow” component of the signal represents the integrated charge collected at the detector anode which is proportional to the total energy of the incoming photon, while the “fast” value mainly depends on the position of the interaction with respect to the collecting electrode. The ratio

Manuscript received

Natalia Auricchio, Filomena Schiavone, Ezio Caroli, Angelo Basili and John B. Stephen are with INAF/IASFBologna, Bologna, 40129 Italy. (tel.: +390516398779, e-mail: auricchio@iasfbo.inaf.it).

Andrea Zappettini is with IMEM/CNR, Parma, 43100 Italy.

between the two signals ($R = V_{Fast}/V_{Slow}$) is an indirect measurement of the interaction position between the collecting electrodes [1, 2]. The off-line analysis of both signal components allows us to recover the loss of the charge inside the crystal and, as a consequence, to reconstruct the energy of the primary photon.

III. EXPERIMENTAL SET-UP

We report in Fig. 1 the experimental set-up used for the bi-parametric data acquisition.

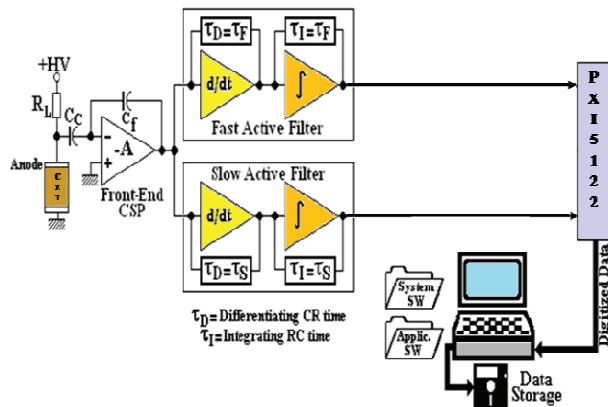

Fig. 1. Experimental set-up utilized for the bi-parametric data acquisition.

The cathode is connected to the ground while the anode signals are coupled to a charge sensitive preamplifier (eV-5093), through a decoupling capacitor. The analogue post-processing is performed with standard NIM instrumentation. A National Instruments PXI-5122 Digitizer is used to perform the 14 bit A-to-D conversion of each amplitude pair and a dedicated LABVIEW procedure is used both to control the acquisition and to handle the data collection by means of a graphics user interface (GUI), as we can see in Fig. 2.

We have tested three CdZnTe detectors realized by CNR/IMEM with sputtered platinum contacts, of area 5 mm x 5 mm, thickness from 2.15 mm to 2.75 mm and grown by the Vertical Bridgman technique. These detectors were glued with silver paste on a lexan support and bonded with Au wire of 25 μ m to the electrodes [3, 4].

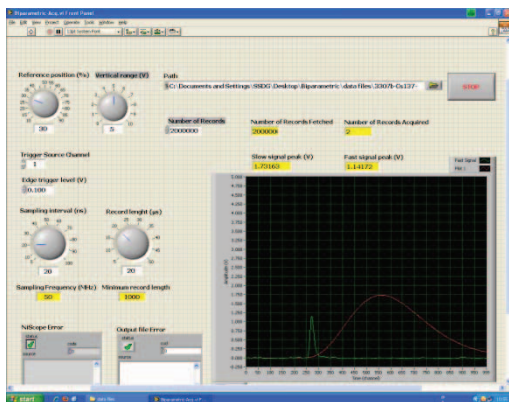

Fig. 2. Graphics User Interface used to control the acquisition and to handle the data collection.

IV. DETECTOR CHARACTERIZATION

The electrical and transport properties ($\mu\tau$ product) have been studied by acquiring the leakage currents as well as by determining the response to the irradiation with different calibration sources (^{241}Am , ^{57}Co , ^{109}Cd , ^{133}Ba and ^{137}Cs) at different shaping times. We have carried out this spectroscopic characterization for all three detectors.

The I-V measurements have been performed by means of a current generator-voltage gauge unit (Keithley 236). Data acquisition was automatic and performed connecting a Macintosh computer with the Keithley unit. In Fig. 3 the leakage current is displayed as a function of the bias voltage.

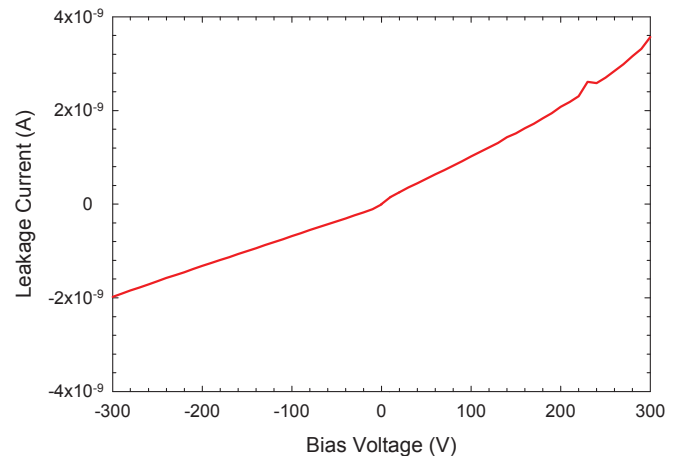

Fig. 3. Leakage current vs. bias voltage.

Some spectra acquired by irradiating through the cathode are illustrated in Fig. 4 and 5. We can see the main lines at ~ 31 keV, 81 keV and 356 keV in the spectrum reported at the bottom of Fig. 5, obtained by illuminating a detector with the ^{133}Ba radioactive source.

The electron mobility-lifetime product measurement is reported in Fig. 6: $(\mu\tau)_e$ is $(2.6 \pm 0.2) 10^{-3} \text{ cm}^2/\text{V}$.

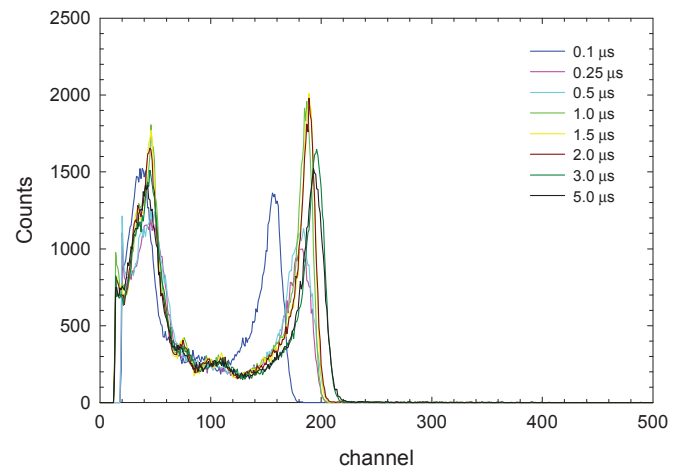

Fig. 4. ^{241}Am energy spectra recorded at different shaping times, by irradiating a sample.

The values of the energy resolution (FWHM) calculated at ~ 22.1 , 59.54, 88 and 122 are reported in Table I.

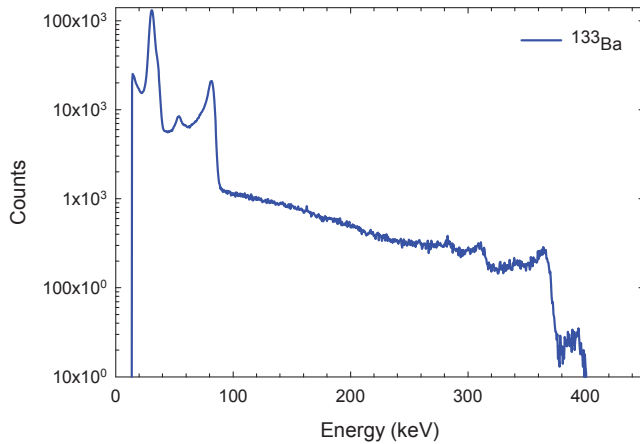
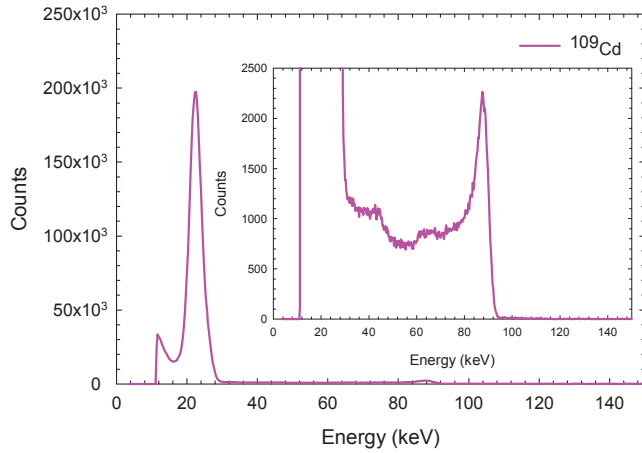
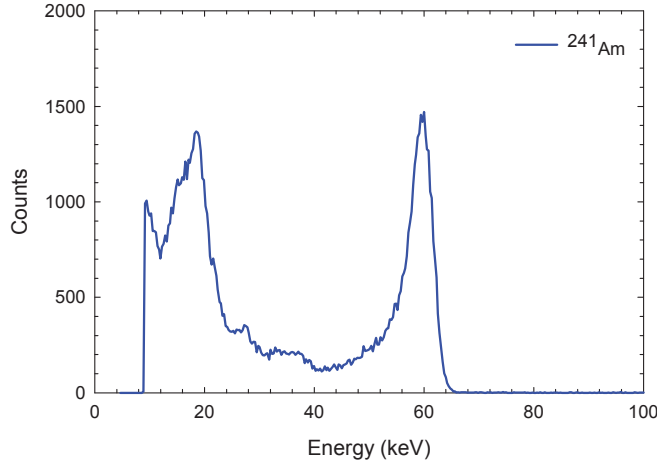

Fig. 5. Energy spectra recorded at different energies of the incident photons, by irradiating the detector with ^{241}Am (top), ^{109}Cd (center) and ^{133}Ba (bottom).

TABLE I
FWHM AT DIFFERENT ENERGIES.

Energy (keV)	FWHM (keV)
22.10	4.3
59.54	3.9
88.04	4.7
122.06	5.4

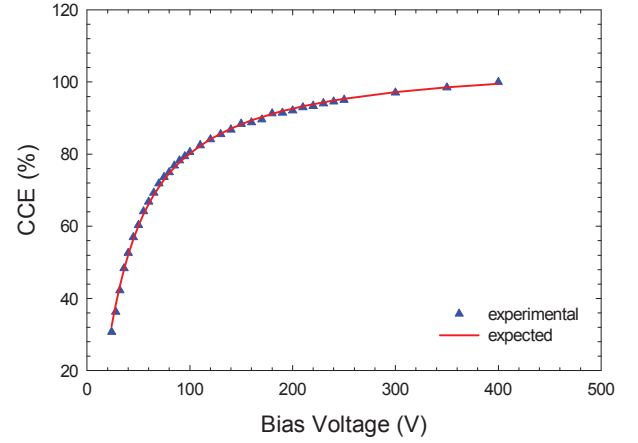

Fig. 6. Charge Collection Efficiency as a function of the bias voltage applied to one of the three detectors. $(\mu\tau)_e = (2.6 \pm 0.2) 10^{-3} \text{ cm}^2/\text{V}$.

V. BI-PARAMETRIC DATA

The data collected with the experimental set-up displayed in Fig. 1 are used to fill a two-dimensional map in which the horizontal axis reports the “slow” signals while the vertical axis represents the “fast/slow” ratios ($R = V_{\text{Fast}}/V_{\text{Slow}}$).

The bi-parametric distribution acquired with ^{137}Cs at the bias voltage of 300 V is shown in Fig. 7. In this map it is possible to distinguish the photopeak structure at 662 keV and the Compton edge. We have also increased the bias voltage up to 600 V to improve the charge collection, as we can see in Fig. 8 in the map recorded with the same shaping time pair, where the interaction depth is enhanced.

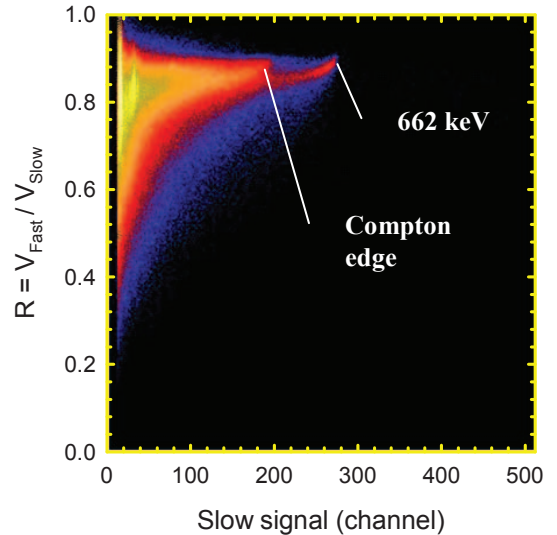

Fig. 7. Ratio $V_{\text{Fast}} / V_{\text{Slow}}$ versus slow signal map obtained with a ^{137}Cs source, shaping time pair of 0.25–3.0 μs and by biasing the detector at 300 V.

To compensate the maps we have applied a compensation algorithm to each pair (fast, slow), calculated by using (1):

$$E_{\text{comp}} = \left[\frac{E_{\text{max}}}{E_{\text{slow}}} \right] \times G(\text{ratio}) \quad (1)$$

where E_{max} corresponds to the centroid in the best spectroscopy region and $G(\text{ratio})$ is a function which represents the best fit of E_{slow} as a function of the ratio values.

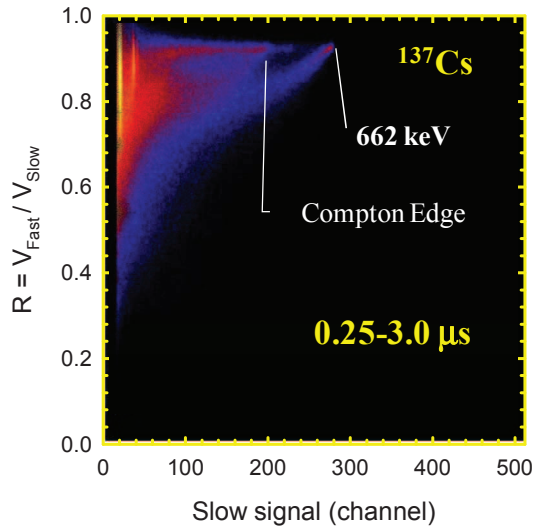

Fig. 8. Ratio V_{Fast}/V_{Slow} versus slow signal map obtained with a ^{137}Cs source, using the same 0.25–3.0 μs shaping time pair at 600 V.

In Fig. 9 we report the corrected maps obtained by applying two different fits, a polynomial and a power law respectively. It is worth noting that the photopeak structure is compensated.

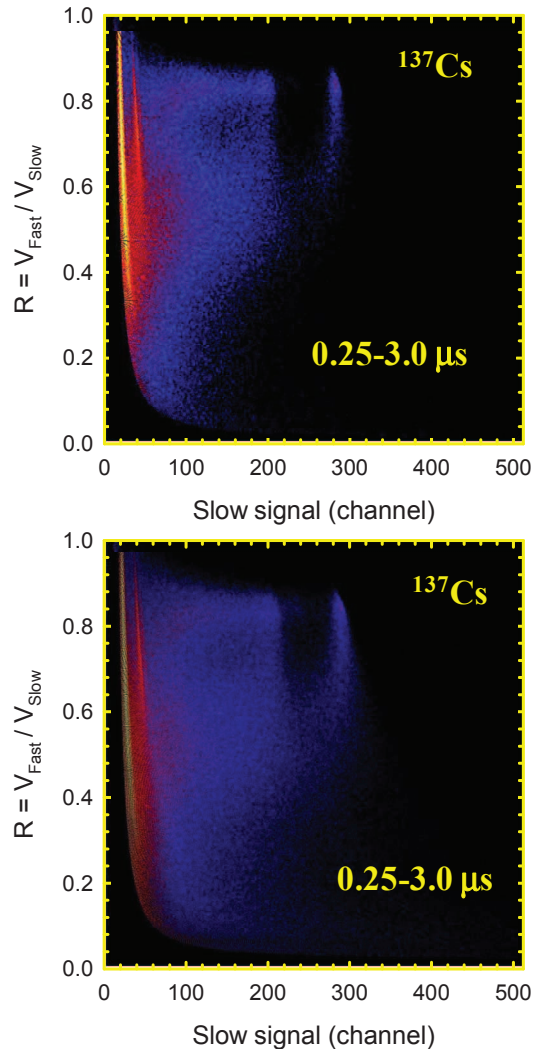

Fig. 9. Corrected maps obtained with a ^{137}Cs source. The data were acquired by using the 0.25–3.0 μs shaping time pair at 600 V. $G(\text{ratio})$ is fitted with a polynomial law (top) and a power law (bottom).

Fig. 10 shows the compensated spectra by applying both laws.

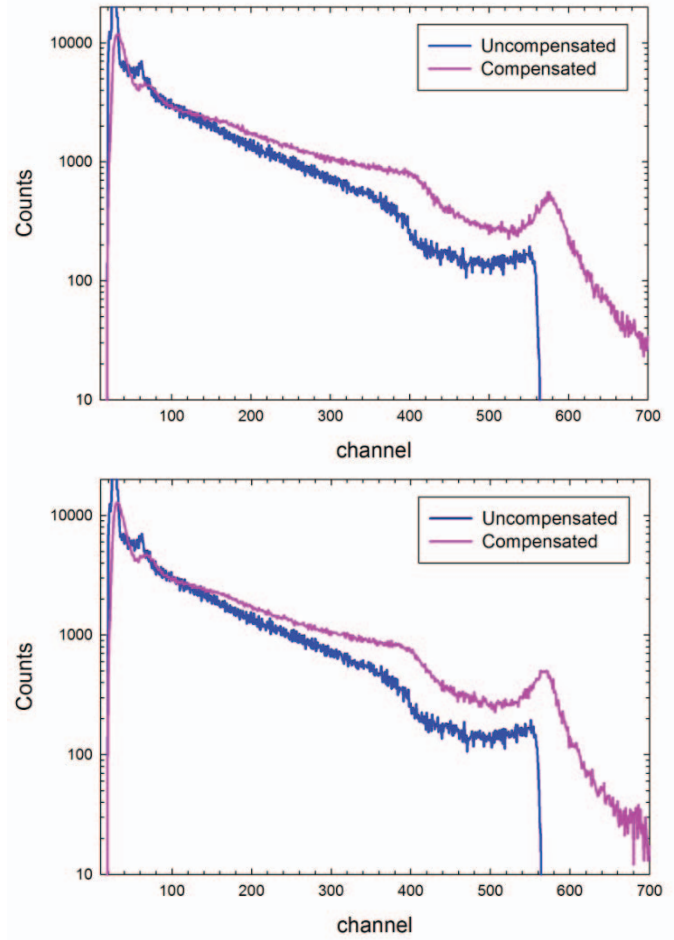

Fig. 10. ^{137}Cs spectra acquired at 600V with a 0.25–3.0 μs shaping time pair. The pink plot represents the original spectrum, while the blue one is the spectrum after the compensation.

VI. WORK IN PROGRESS

The data analysis is in progress in order to obtain the corrected spectra acquired at several bias voltages, with different shaping time pairs and compare the results with those achieved by detectors of different quality grades.

We want to point out that this technique could be implemented in an array of detectors, with front-end electronics composed of ASICs where the shaping time can be selected for each channel, like the RENA-3 IC (NOVA R&D).

REFERENCES

- [1] N. Auricchio, et al., “Compensation of CdZnTe Signals using a Twin Shaping Filter Technique”, *IEEE Trans. Nucl. Sci.*, Vol. 51, No. 5, pp. 2485-2491 (2004).
- [2] N. Auricchio, et al., “Twin Shaping Filter Techniques to Compensate the Signals from CZT/CdTe Detectors”, *IEEE Trans. Nucl. Sci.*, Vol. 52, No. 5, pp. 1982-1988 (2005).
- [3] A. Zappettini, et al., “Growth and Characterization of CZT Crystals by the Vertical Bridgman Method for X-Ray Detector Applications.”, *IEEE Trans. Nucl. Sci.*, Vol. 58, No. 5, pp. 2352- 2356 (2011).
- [4] N. Auricchio, et al., “Twin Shaping Filter Technique for signals compensation in CZT Detectors Grown by the Vertical Bridgman method”, *IEEE Nuclear Science Symposium Conference Record*, RTSD.S-292, pp. 4642- 4645 (2011).