



<b>Publication Year</b>	2022
<b>Acceptance in OA</b>	2025-03-07T11:15:51Z
<b>Title</b>	The instrument control unit of the ARIEL payload: design evolution following the unit and payload subsystems SRR (system requirements review)
<b>Authors</b>	NOCE, Vladimiro, FOCARDI, Mauro, DI GIORGIO, Anna Maria, GALLI, Emanuele, FARINA, Maria, GIUSI, Giovanni, VELA NUNEZ, Marina, NAPONIELLO, LUCA, LORENZANI, Andrea, Serafini, Luca, DEL VECCHIO BLANCO, CARLO, Verna, Marco, Cara, Christophe, Berthé, Michel, Martignac, Jerome, Ottensamer, Roland, MICELA, Giuseppina, MALAGUTI, GIUSEPPE, Pace, Emanuele, Preti, Giampaolo, Miceli, Federico, Pascale, Enzo, Tinetti, Giovanna, Eccleston, Paul, Tommasi, Elisabetta, De Persio, Fulvio, BOLLI, Pietro, NESTI, Renzo, IUZZOLINO, Marcella, CARBONARO, Luca, DEL VECCHIO, Ciro, FERRUZZI, Debora, BRUCALASSI, Anna, FALCINI, Gilberto, TOZZI, Andrea, GOTTINI, Daniele
<b>Publisher's version (DOI)</b>	10.1117/12.2628172
<b>Handle</b>	<a href="http://hdl.handle.net/20.500.12386/36477">http://hdl.handle.net/20.500.12386/36477</a>
<b>Serie</b>	PROCEEDINGS OF SPIE
<b>Volume</b>	12180

# The Instrument Control Unit of the ARIEL payload: design evolution following the Unit and Payload subsystems SRR (System Requirements Review)

Vladimiro Noce<sup>a</sup>, Mauro Focardi<sup>a</sup>, Anna Maria Di Giorgio<sup>h</sup>, Emanuele Galli<sup>h</sup>, Maria Farina<sup>h</sup>, Giovanni Giusi<sup>h</sup>, Marina Vela Nunez<sup>a</sup>, Luca Naponiello<sup>i</sup>, Andrea Lorenzani<sup>a</sup>, Luca Serafini<sup>b</sup>, Carlo Del Vecchio Blanco<sup>b</sup>, Marco Verna<sup>b</sup>, Christophe Cara<sup>c</sup>, Michel Berthé<sup>c</sup>, Jerome Martignac<sup>c</sup>, Roland Ottensamer<sup>j</sup>, Giuseppina Micela<sup>k</sup>, Giuseppe Malaguti<sup>l</sup>, Natalia Auricchio<sup>l</sup>, Emanuele Pace<sup>d</sup>, Giampaolo Preti<sup>d</sup>, Federico Miceli<sup>a,d</sup>, Enzo Pascale<sup>i</sup>, Giovanna Tinetti<sup>g</sup>, Paul Eccleston<sup>e</sup>, Elisabetta Tommasi<sup>f</sup>, Fulvio De Persio<sup>f</sup>, Pietro Bolli<sup>a</sup>, Renzo Nesti<sup>a</sup>, Marcella Iuzzolino<sup>a</sup>, Luca Carbonaro<sup>a</sup>, Ciro Del Vecchio<sup>a</sup>, Debora Ferruzzi<sup>a</sup>, Anna Brucalassi<sup>a</sup>, Gilberto Falcini<sup>a</sup>, Andrea Tozzi<sup>a</sup>, Daniele Gottini<sup>a</sup>, and the ARIEL team

<sup>a</sup>INAF - Osservatorio Astrofisico di Arcetri, Largo Enrico Fermi 5, Firenze, Italy

<sup>b</sup>Kayser Italia, Via di Popogna 501, Livorno, Italy

<sup>c</sup>CEA-Irfu - Department of Astrophysics, Gif-sur-Yvette, France

<sup>d</sup>University of Florence - Department of Physics and Astronomy, L.go E. Fermi 2, Firenze, Italy

<sup>e</sup>UKRI-RAL - Rutherford Appleton Laboratory, Harwell Campus, Didcot, UK

<sup>f</sup>ASI - Italian Space Agency, Via Ravà 106, Roma, Italy

<sup>g</sup>UCL - University College London, Astrophysics group, London, UK

<sup>h</sup>INAF/IAPS - Institute of Space Astrophysics and Planetology, Via del Fosso Cavaliere 100, Roma, Italy

<sup>i</sup>La Sapienza University, Piazzale Aldo Moro 5, Roma, Italy

<sup>j</sup>University of Vienna - Institute of Astronomy, Türkenschanzstraße 17, Vienna, Austria

<sup>k</sup>INAF-OAPa, Palermo Astronomical Observatory, P.zza del Parlamento 1, Palermo, Italy

<sup>l</sup>INAF-OAS, Astrophysical and Space Science Observatory, Via Gobetti 93/3, Bologna, Italy

## ABSTRACT

ARIEL (Atmospheric Remote-sensing InfraRed Large-survey) is a medium-class mission of the European Space Agency, part of the Cosmic Vision program, whose launch is foreseen by early 2029. ARIEL aims to study the composition of exoplanet atmospheres, their formation and evolution. The ARIEL's target will be a sample of about 1000 planets observed with one or more of the following methods: transit, eclipse and phase-curve spectroscopy, at both visible and infrared wavelengths simultaneously. The scientific payload is composed by a reflective telescope having a 1m-class elliptical primary mirror, built in solid Aluminium, and two focal-plane instruments: FGS and AIRS.

FGS (Fine Guidance System)<sup>1</sup> has the double purpose, as suggested by its name, of performing photometry (0.50-0.55  $\mu\text{m}$ ) and low resolution spectrometry over three bands (from 0.8 to 1.95  $\mu\text{m}$ ) and, simultaneously, to provide data to the spacecraft AOCS (Attitude and Orbit Control System) with a cadence of 10 Hz and contributing to reach a 0.02 arcsec pointing accuracy for bright targets.

AIRS (ARIEL InfraRed Spectrometer) instrument will perform IR spectrometry in two wavelength ranges: between 1.95 and 3.9  $\mu\text{m}$  (with a spectral resolution  $R > 100$ ) and between 3.9 and 7.8  $\mu\text{m}$  with a spectral resolution  $R > 30$ .

---

Further author information: (Send correspondence to M.F. or V.N.)

M.F.: E-mail: mauro.focardi@inaf.it, Telephone: +39 055 275 2260

V.N.: E-mail: vladimiro.noce@inaf.it, Telephone: +39 055 275 2240

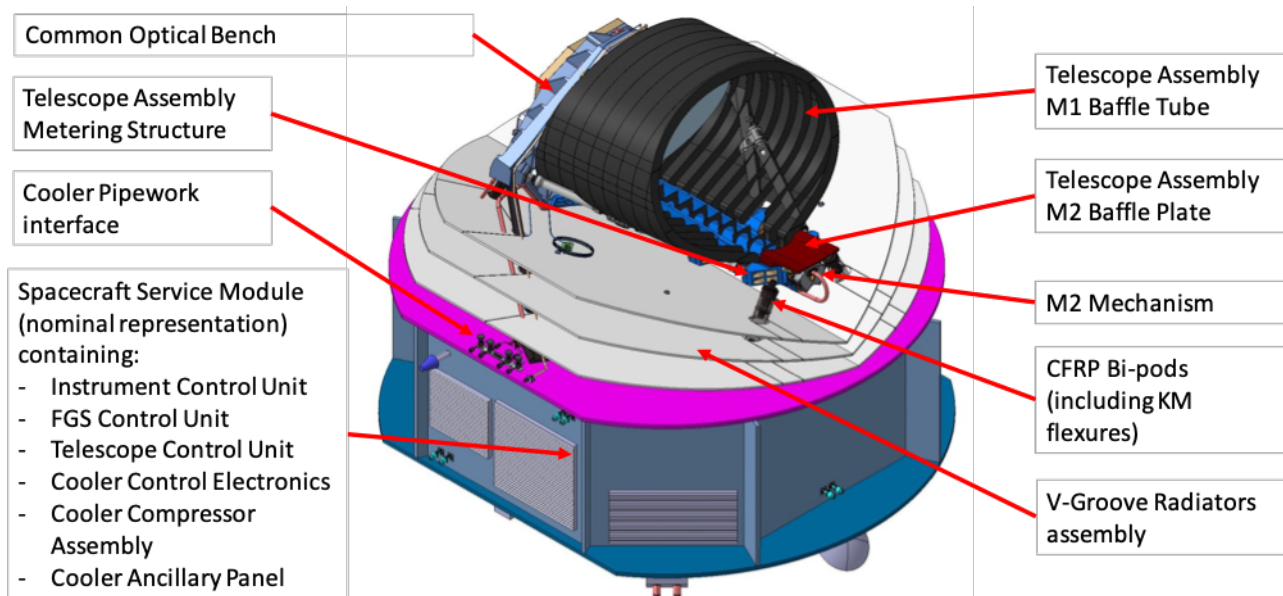

Figure 1: An image representing the ARIEL S/C with the main components. The ICU is hosted inside the SVM (bottom).

This paper provides the status of the ICU (Instrument Control Unit), an electronic box whose purpose is to command and supply power to AIRS (as well as acquire science data from its two channels) and to command and control the TCU (Telescope Control Unit).

**Keywords:** Exoplanets atmospheres, NIR spectroscopy, Infrared radiation, Infrared telescopes, Remote sensing, Instrument Control Unit

## 1. INTRODUCTION

ARIEL (Atmospheric Remote-sensing InfraRed Large-survey)<sup>23</sup> is a medium-class (M4) mission part of the Cosmic Vision program of the European Space Agency. The launch is planned by early 2029 and the duration is 4 years plus 2 years of extended mission.

ARIEL's scientific purpose is the study of the composition of exoplanet atmospheres,<sup>4</sup> their formation and evolution, by performing infrared spectroscopy of a large number of transiting exoplanets with temperatures from  $\sim 500\text{ K}$  to  $\sim 3000\text{ K}$ . During its mission ARIEL will observe about 1000 planets with one or more of the following methods: transit, eclipse and phase-curve spectroscopy.

The ARIEL<sup>56</sup> spacecraft hosts an off-axis Cassegrain IR telescope with an elliptic  $1\text{ m} \times 0.7\text{ m}$  primary mirror, built in Aluminium and feeding, by means of a system of optics (dichroics, mirrors and prisms) two instruments:

- AIRS (ARIEL InfraRed Spectrometer) that will perform IR spectrometry in two wavelength ranges: between  $1.95$  and  $3.9\ \mu\text{m}$  and between  $3.9$  and  $7.8\ \mu\text{m}$ .
- FGS (Fine Guidance System), an instrument with three narrow-band (from visible to near-infrared) photometer channels (two of these are used as guidance sensors as well as for science) and a low-resolution near-infrared spectrometer.

This paper reports the AIRS ICU design status and gives an overview of its development stage just before the Payload and Instrument PDRs (Preliminary Design Reviews)<sup>7</sup> that represent a milestone for the ICU design definition and for the construction of the engineering model (EM), the first between the ones foreseen by the model philosophy illustrated in Section 4.1. In Section 2 we describe the AIRS instrument, in Sections 3.1 and

3.2 we go in detail with the internal architecture of the boards composing the ICU and in Section 4 we illustrate the ICU development plan, including a description of the past, present and future activities.

## 2. THE INSTRUMENT CONTROL UNIT ROLE

The ARIEL IR Spectrometer (AIRS)<sup>3</sup> is an instrument performing high stability spectroscopy in two different wavelength bands: from 1.95 to 3.9  $\mu\text{m}$  (channel 0, CH0), and from 3.9 to 7.9  $\mu\text{m}$  (channel 1, CH1). The resolving power is greater than 100 for channel 0 and greater than 30 for channel 1. The scientific data will result in cropped windows of about  $300 \times 64$  pixels for CH0 and  $100 \times 64$  pixels for CH1. The number of levels (depth) for H2RG detectors is 16 bits.

### 2.1 AIRS structure

The light collimated by the telescope is folded by mirrors and split in the various wavelength components by an optic system based on dichroics. The component with larger wavelength ( $> 1.95\mu\text{m}$ ) is fed to the AIRS box. The AIRS instrument is composed of:

1. A metallic enclosure situated in the cold part of the payload (@ 55 K) in the instrument bay, a cavity carved in the Telescope Optical Bench (TOB), containing, for each channel:
  - (a) The final parts of the optics (slits, folding mirrors, prisms (the dispersive elements), filters etc.);
  - (b) Two H2RG (Teledyne) detectors, cooled down to 42 K by a cold finger;
  - (c) The cold Front-End Electronics (cFEE).
2. The DCU (warm Front-End Electronics): an electronic box accommodated in the “warm” side of the spacecraft,<sup>5</sup> at a temperature of about 300 K. The two DCU modules control and read out the detectors.

Figure 2 shows a scheme of the AIRS system, from the cold part of the Payload Module containing the detectors and the cFEE to the warm FEE (A-DCUs). ICU connects to A-DCU on the right of the figure by means of two SpW connectors (MDM9) and two Power connectors (DSub9) for each A-DCU module.

The ICU is the interface with AIRS, managing the data streams (Science and *Housekeeping*, HK) coming from the AIRS instrument and commanding the two DCU, each one demanded to processing the data of one AIRS channel.

### 2.2 ARIEL DCU

Into the cFEE it is implemented the preamplifier for the ROIC (ReadOut Integrated Circuit). Others functions, such as the readout clock sequencer and bias voltages generation reside into the warm electronics (A-DCU). Figure 3 illustrates the distribution of functions between the A-DCU and the CFEE.

The A-DCU main functions are:

- Send commands and the necessary secondary voltages to the cold Front-End Electronics;
- Digitize the scientific data from the detector prior the formatting of the Science Data Packets done by ICU;
- Ensure the proper interface with the ICU for Telecommands (TC) reception, Science and HK Data Packet transmission;
- Control of the thermal stability of detectors (duplicated to increase reliability).

The ICU is connected to the DCUs by means of four SpW (SpaceWire) links, two of them come from the nominal CDPUs and two from the redundant one. The ICU provides also the secondary power to the DCUs (analog  $\pm 6\text{V}$  and digital +5V). See Figure 4.

Beside the DCUs, the ICU is also connected downstream by a cross-strapped serial link to the Telescope Control Unit (TCU), a warm electronics box managing the Thermal Control System (TCS) and the Mirror#2 refocusing Mechanism (M2M).

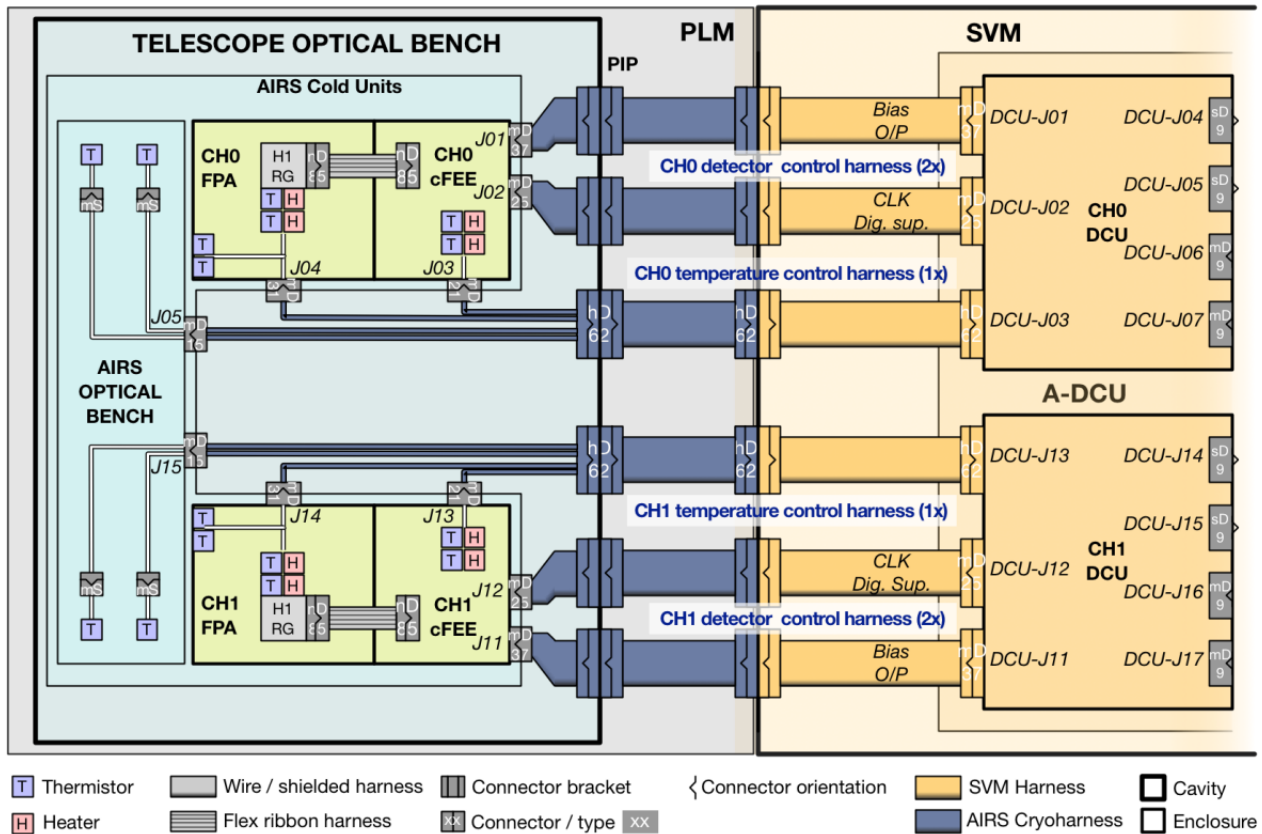

Figure 2: AIRS structure (Courtesy CEA).

### 2.3 TCU

The Telescope Control Unit is another warm electronic box depending from the ICU that is in charge of:

- Driving the Mirror#2 Mechanism (M2MD);
- Managing the Payload Thermal Control System (TCS).

The TCU logic is based on a FPGA and it is completely dependent from ICU for what concerns receiving telecommands from the Service Vehicle Module (SVM) and sending back housekeeping data (HK/TM). The M2M Driver interprets the telecommands received from the ICU providing the switching sequences to the M2M motors and acquiring the status information in form of housekeeping telemetries to be provided to the FPGA and forwarded to the ICU.

With respect to the power supply generation, the TCU is completely autonomous from ICU: in fact, the TCU receives the primary voltage (+28V) directly from the S/C and operates all the necessary conversions through a dedicated internal board.

TCU is a fully redundant system and is connected to ICU by means of a cross-strapped SPI (Serial Peripheral Interface) based on LVDS signals and implementing a custom protocol derived from the one used on Euclid-VIS. The TCU design and realization responsibilities are in charge of IECC (Spain) and part of the boards are realized by the industry (SENER).

## 3. ICU DESCRIPTION

The ICU<sup>8</sup> system is made up of two redundant boards: the CDPU (Control and Data Processing Unit) and the PSU (Power Supply Unit). Its total estimated mass is 6.7 kg (8 kg including Design Maturity Margin) and it

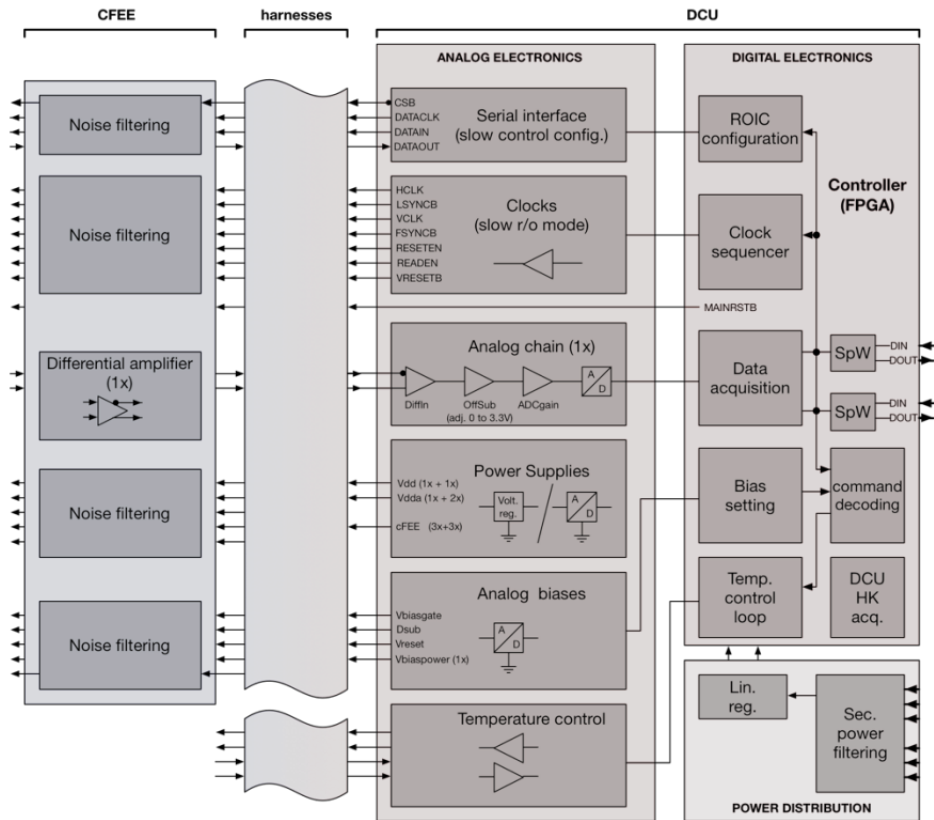

Figure 3: ARIEL DCU Electrical Block Diagram (Courtesy CEA).

has an allocated power of 37 W. The ICU is connected to the SVM through four cross-strapped SpW links for data transmission, while the ICU is powered by two DSub9 connectors (Nominal and Redundant) carrying the +28V primary voltage.

### 3.1 CDPU board

The CDPU hosts a CPU (GR-712RC dual-core processor from Cobham Gaisler) and a FPGA (Microsemi RTAXS1000 type). It is equipped with several types of memory:

- **PROM** to host permanently the Boot Software (128kB);
- **MRAM** Magnetic RAM (Non-Volatile Memory) to store the Application Software (8MB);
- **SDRAM** to buffer data (256MB);
- **SRAM** working memory for ASW processing (4MB).

All these memories (with the exception of the PROM that is One Time Programmable) are protected against events caused by radiation by an EDAC system (Error Detection and Correction). The two main CDPU components, that is the CPU and the FPGA, are connected through an internal SPI bus.

The CPU is based on the Leon3-FT (Fault Tolerant), a synthesizable 32-bit SPARC-V8 processor, suitable for space applications. It will run the Application SW in charge of the AIRS instrument and of the TCU management. It will also process data (science and housekeeping) collected from the monitored subsystems.

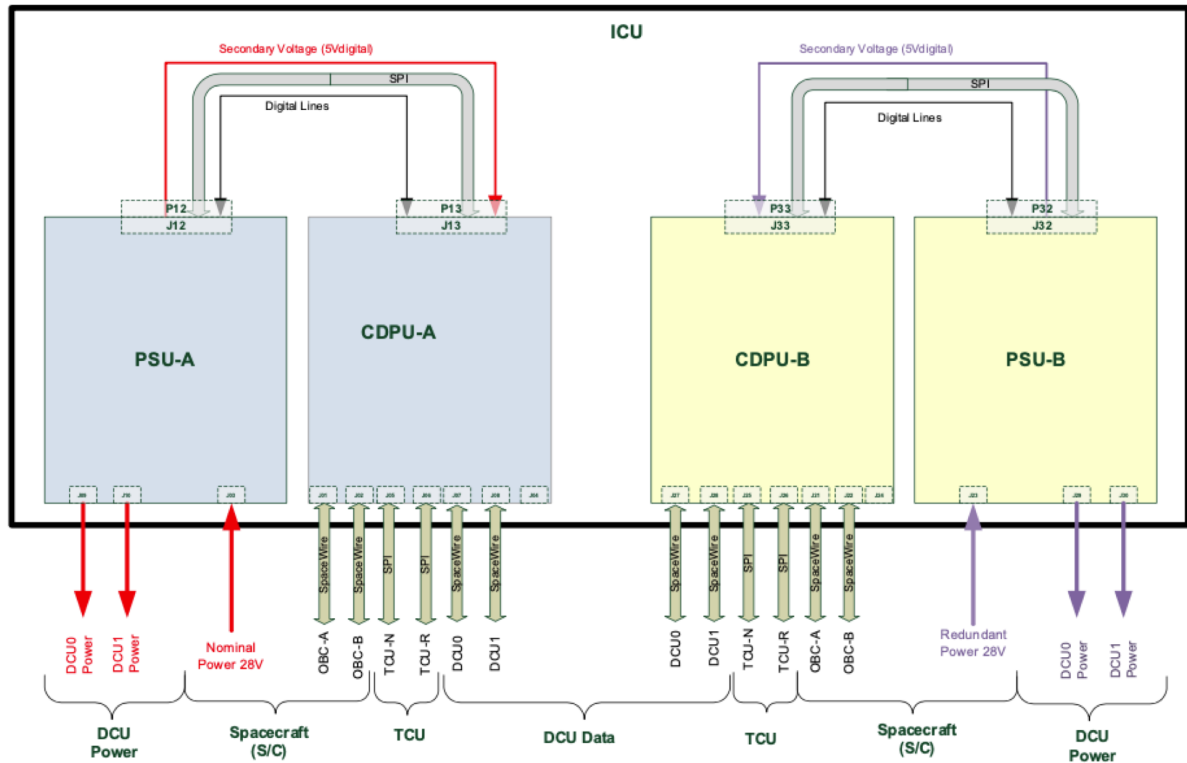

Figure 4: ICU internal architecture and data interfaces (Courtesy KI).

The FPGA role is to provide additional computational resources to accomplish the compression task on scientific data (2.5 compression ratio), but, also, to add ports for communications. In fact, the GR712RC has only six SpaceWire ports, not sufficient for all the communication needs as shown in Figure 4. The FPGA modules shall be developed using VHDL language, so it will be possible to test the design using reprogrammable (A3PE3000) devices for prototyping phases and migrate easily the design to flight representative models (RTAXS1000, programmable only once) devices.

### 3.2 PSU board description

The PSU (Power Supply Unit) is the (redundant) board present in the ICU and whose purpose is to transform the primary voltage (+28V) into secondary voltages to supply the internal electronics (CDPU) as well as the AIRS wFEE (A-DCU) and, by means of the latter, the cFEE and the AIRS detectors.

The PSU hosts DC/DC converters for internal power regulation and an isolated section to provide secondary voltages to the A-DCUs. The power conditioning sections is protected against polarity inversion and has EMI filtering at its input. The PSU is also in charge of monitoring currents, voltages and temperature on internal and secondary outputs, to convert them using a 12-bit serial ADC and to provide housekeeping data to CDPU to be further transmitted to the SVM. Concerning the isolated section, the HK acquisition represented an additional challenge in design due to the need to use optoisolators.

The distributed power is equipped with over-voltage protection and LCLs (Latching Current Limiters, see Figure 6), switching off the power in case the currents exceed the limit. No active limitation of the in-rush current is foreseen (that is controlled upstream by the SVM LCL function); the maximum variation ( $1A/\mu s$ ) is guaranteed by the passive circuitry of the input EMI filter. The CDPU over-voltage protection is based on a comparator with hysteresis without latching. In case of a temporary over-voltage, the CDPU and the DCUs are switched off and re-enabled by an automatic reset. The power status of the DCUs is sent via telemetry to the SVM, provided that the CDPU is on, otherwise no telemetry can be sent.



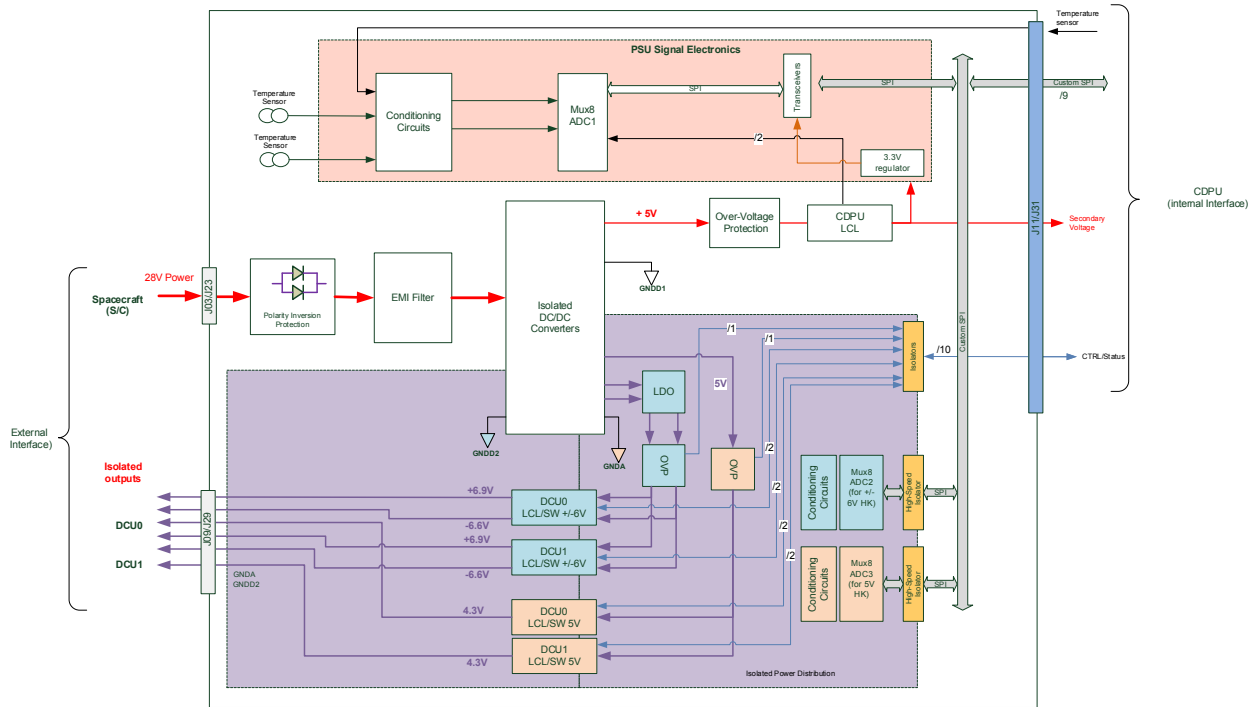

Figure 6: PSU module block diagram (Courtesy KI).

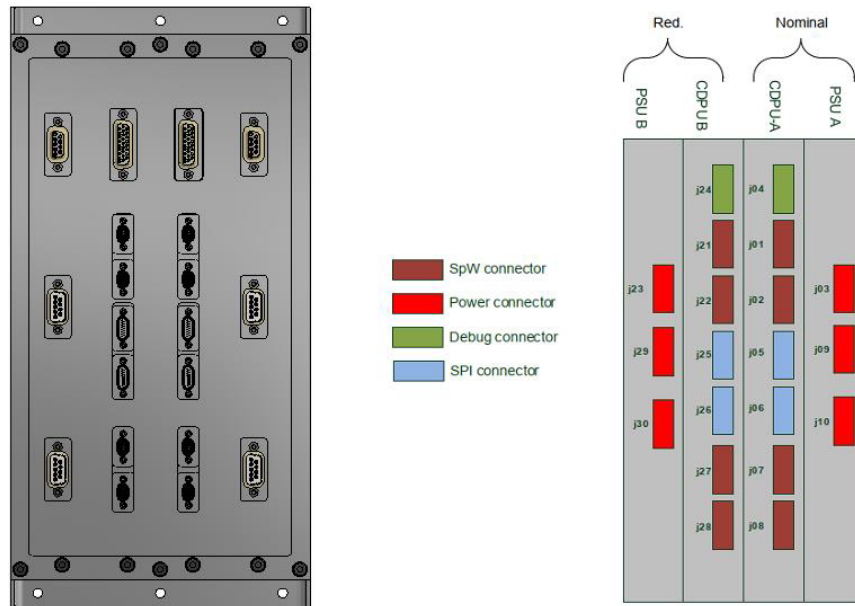
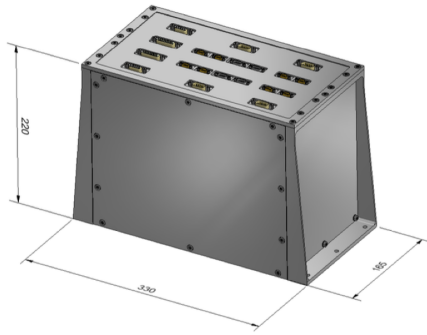

Figure 7: Connectors allocation on the top of the ICU box (Courtesy KI).

on the module's frames (made of the same type of Aluminium, but chromatised, as per MIL-DTL-5541F). The thermo-mechanical coupling with the lateral panels of the box structure is guaranteed by the *Card-Lok* retainers mounted on each frame.

The allocated dimensions for the box are 330 mm x 220 mm x 220 mm (length x width x height). The present dimensions of the box are 330 mm x 165 mm x 220 mm, so some margin in width is still available.



(a) The ICU box mechanical drawing.

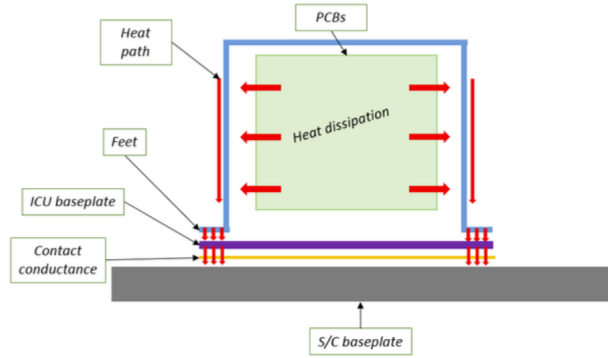

(b) A sketch of the mechanical enclosure, showing the heat fluxes through the lateral *Card-Lok* retainers.

Figure 8: Two images of the ICU mechanical structure (Courtesy KI).

## 4. ICU ACTIVITIES

### 4.1 ICU Model Philosophy

The ICU Model Philosophy, comprises the following models:

1. **Breadboard (BB)** a Cobham-Gaisler GR712RC development board, used for Application SW development;
2. **Engineering Model (EM)**, functional and electrical representative of flight standard, used for Application SW development (one board) and for EM campaign at RAL;
3. **Engineering Qualification Model (EQM)**, flight representative in form, fit and functions, i.e. including electrical, printed circuit boards, thermal, mechanical fidelity, used for SW development, not a deliverable, can be used for qualification activities;
4. **Avionics Verification Model (AVM)**, EM build standard, functionally representative and with flight representative interfaces. Contributes to the spacecraft AVM campaign;
5. **Flight Model (FM)**, final model for integration in ARIEL PL and launch;
6. **Flight Spare (FS)**, flight spare, ready to substitute one of the FM boards in case of major problems.

Table 1: ICU models utilization summary.

Model	# of ch.	Purpose	Notes
EM	2	assess design & SW development	deliv. to RAL for EM camp.
AVM	2	contributes to S/C AVM camp.	deliv. to ESA/ADS
EQM	2	SW development	not deliverable to RAL
PFM	2	complete acceptance tests at box level	integrated in PL FM
FS	1	limited acceptance tests at board level	

### 4.2 SW development

All the hardware described until now needs, to be functional, different kind of SW.

The OS (Operative System) is a commercial components, but the Boot SW and the drivers (Basic Support Package, BSP) interfacing the Application Software with the OS are custom and are developed by the same industry realizing the ICU (Kayser Italia).

The Boot SW, which is responsible to boot the ICU Application Software, is a simple but, at the same time, very critical piece of software because it is not replaceable when in space. Due to its uniqueness, it has to be carefully developed and extensively tested before the final version. The flight BSW is burned in an OTP (One Time Programmable) PROM.

The Application SW (ASW), developed by INAF-IAPS (Institute for Astrophysics and Space Planetology), is the software running on the CPU that implements all the features needed to satisfy the mission needs. It is also responsible to implement the FDIR (Fault Detection Isolation and Recovery) procedures for the ICU, the A-DCUs and the TCU, to manage the SpaceWire network and routing etc. The Compression Software (CSW) is the part of the ASW implementing the lossless compression routines. Finally, the FPGA is programmed in VHDL language (FW provided by KI as well).

#### 4.2.1 EGSE

The EGSE (Electrical Ground Support Equipment) are HW and SW equipment designed and developed to support the ICU tests and integration at board and at system level.

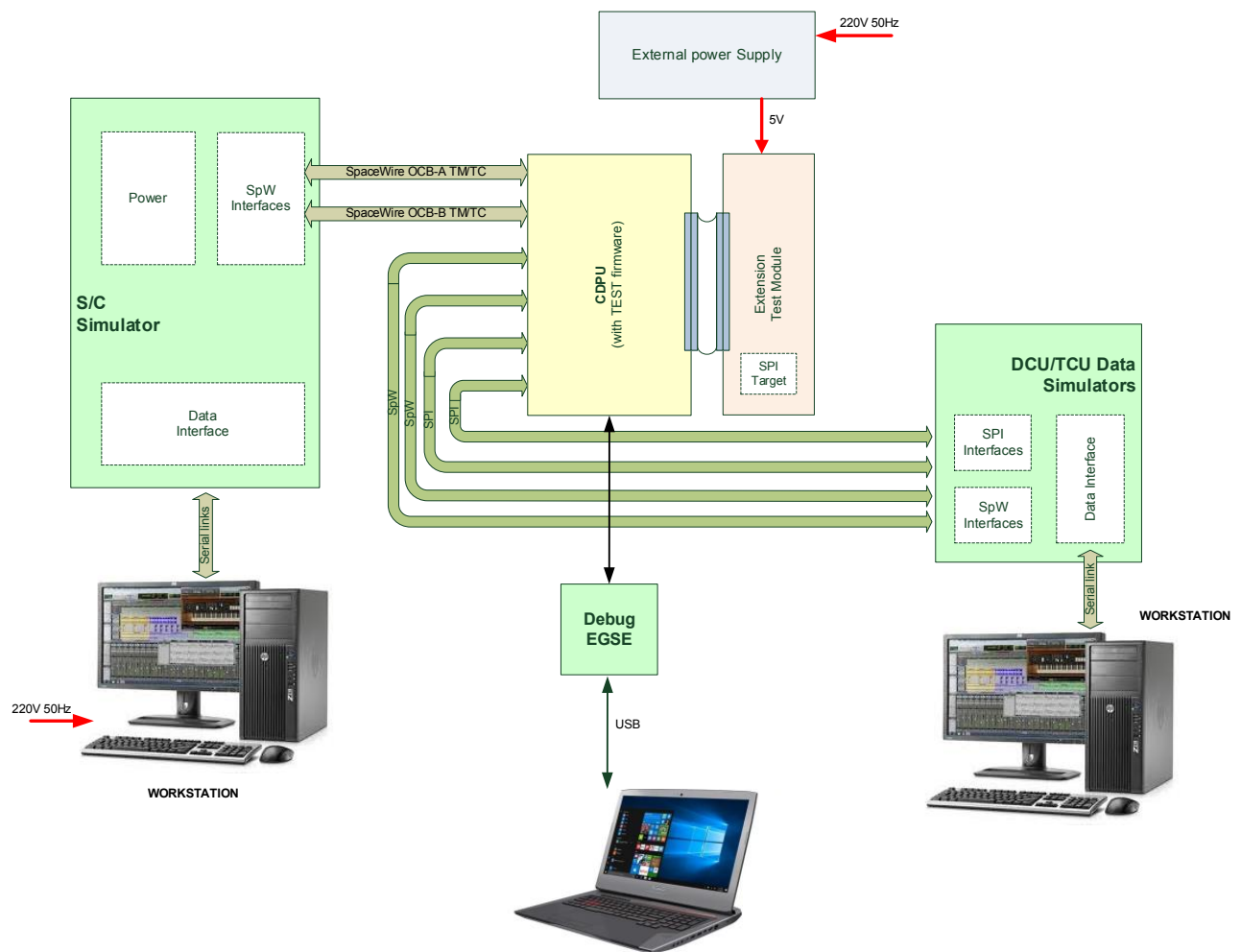

Figure 9: Example of EGSE usage for CDPU testing at board level (Courtesy KI).

The main EGSEs created to support the ICU development are:

1. An ARIEL S/C Simulator composed by:

- A workstation simulating S/C data transmission that will communicate with the ICU implementing the CCSDS/PUS protocol over SpaceWire;
  - 4 SpW link @ 100Mbps;
  - A power supply to provide the primary +28V to ICU.
2. A DCU or TCU simulator composed by:
- A workstation simulating A-DCU (TCU) data transmission implementing high-level protocols over SpW (SPI) links and generating dummy telemetry.
  - 4 SpW (@100 Mbps for A-DCUs) and 4 SPI (@1 Mbps for TCU) interfaces;
  - A-DCU simulated power loads.
3. ARIEL Debug EGSE, used to debug and monitor the ICU during development.

In general, the EGSE are not deliverable, but some EGSE, such as the debug boards, could be delivered with the EM and AVM models, so they will be developed in a number and format compatible with the related model.

Other EGSE are developed in order to test the subsystems (CDPU and PSU) at board level before the integration.

## 5. SUMMARY AND CONCLUSIONS

The ICU project has just passed the SRR (System Requirements Review) and is going to face the PDR (Preliminary Design Review) in the second half of this year (2022).

The detailed design of the boards (CDPU and PSU) is on-going and their dimensions and budgets are consolidated. The metallic box has been draft (see Figure 8a) and several analyses (thermal and structural-FEM) have already been performed on this design.

At the beginning of 2023 the first EM model will be produced and, in parallel to the realization of the hardware, several pieces of SW, to be integrated in the ICU, will be developed:

- The Boot SW, the Basic Support Package and the VHDL FPGA code will be developed by the ICU provider (Kayser Italia);
- The Application Software, running on the CPU, will be realized by IAPS;
- The Compression Software is in charge of the University of Vienna.

## ACKNOWLEDGMENTS

This study has been supported by the Italian Space Agency (within the ASI-INAF agreement n. 2021-5-HH.0 “Scientific activity for the ARIEL Mission – B2/C Phases” ).

## REFERENCES

- [1] Rataj, M., Wawer, P., Skup, K., and Sobiecki, M., “Design of fine guidance system (FGS) for ARIEL mission,” in *[Photonics Applications in Astronomy, Communications, Industry, and High-Energy Physics Experiments 2019]*, Romaniuk, R. S. and Linczuk, M., eds., **11176**, 1007 – 1013, International Society for Optics and Photonics, SPIE (2019).
- [2] Puig, L., Pilbratt, G. L., Heske, A., Sanz, I. E., and Crouzet, P.-E., “ARIEL: an ESA M4 mission candidate,” in *[Space Telescopes and Instrumentation 2016: Optical, Infrared, and Millimeter Wave]*, MacEwen, H. A., Fazio, G. G., Lystrup, M., Batalha, N., Siegler, N., and Tong, E. C., eds., **9904**, 649 – 657, International Society for Optics and Photonics, SPIE (2016).

- [3] Pascale, E., Bezawada, N., Barstow, J., Beaulieu, J.-P., Bowles, N., du Foresto, V. C., Coustenis, A., Decin, L., Drossart, P., Eccleston, P., Encrenaz, T., Forget, F., Griffin, M., Güdel, M., Hartogh, P., Heske, A., Lagage, P.-O., Leconte, J., Malaguti, P., Micela, G., Middleton, K., Min, M., Moneti, A., Morales, J. C., Mugnai, L., Ollivier, M., Pace, E., Papageorgiou, A., Pilbratt, G., Puig, L., Rataj, M., Ray, T., Ribas, I., Rocchetto, M., Sarkar, S., Selsis, F., Taylor, W., Tennyson, J., Tinetti, G., Turrini, D., Vandenbussche, B., Venot, O., Waldmann, I. P., Wolkenberg, P., Wright, G., Osorio, M.-R. Z., and Zingales, T., “The ARIEL space mission,” in [*Space Telescopes and Instrumentation 2018: Optical, Infrared, and Millimeter Wave*], Lystrup, M., MacEwen, H. A., Fazio, G. G., Batalha, N., Siegler, N., and Tong, E. C., eds., **10698**, 169 – 178, International Society for Optics and Photonics, SPIE (2018).
- [4] Tinetti, G., Drossart, P., Eccleston, P., Hartogh, P., Heske, A., Leconte, J., Micela, G., Ollivier, M., Pilbratt, G., Puig, L., Turrini, D., Vandenbussche, B., Wolkenberg, P., Pascale, E., Beaulieu, J.-P., Güdel, M., Min, M., Rataj, M., Ray, T., Ribas, I., Barstow, J., Bowles, N., Coustenis, A., du Foresto, V. C., Decin, L., Encrenaz, T., Forget, F., Friswell, M., Griffin, M., Lagage, P. O., Malaguti, P., Moneti, A., Morales, J. C., Pace, E., Rocchetto, M., Sarkar, S., Selsis, F., Taylor, W., Tennyson, J., Venot, O., Waldmann, I. P., Wright, G., Zingales, T., and Zapatero-Osorio, M. R., “The science of ARIEL (Atmospheric Remote-sensing Infrared Exoplanet Large-survey),” in [*Space Telescopes and Instrumentation 2016: Optical, Infrared, and Millimeter Wave*], MacEwen, H. A., Fazio, G. G., Lystrup, M., Batalha, N., Siegler, N., and Tong, E. C., eds., **9904**, 658 – 667, International Society for Optics and Photonics, SPIE (2016).
- [5] Eccleston, P., Tinetti, G., Beaulieu, J.-P., Güdel, M., Hartogh, P., Micela, G., Min, M., Rataj, M., Ray, T., Ribas, I., Vandenbussche, B., Auguères, J.-L., Bishop, G., Deppo, V. D., Focardi, M., Hunt, T., Malaguti, G., Middleton, K., Morgante, G., Ollivier, M., Pace, E., Pascale, E., and Taylor, W., “An integrated payload design for the Atmospheric Remote-sensing Infrared Exoplanet Large-survey (ARIEL),” in [*Space Telescopes and Instrumentation 2016: Optical, Infrared, and Millimeter Wave*], MacEwen, H. A., Fazio, G. G., Lystrup, M., Batalha, N., Siegler, N., and Tong, E. C., eds., **9904**, 1015 – 1030, International Society for Optics and Photonics, SPIE (2016).
- [6] Eccleston, P., Drummond, R., Middleton, K., Bishop, G., Caldwell, A., Desjonqueres, L., Tosh, I., Cann, N., Crook, M., Hills, M., Pearson, C., Simpson, C., Stamper, R., Tinetti, G., Pascale, E., Swain, M., Holmes, W. A., Wong, A., Puig, L., Pilbratt, G., Linder, M., Boudin, N., Ertel, H., Gambicorti, L., Halain, J.-P., Pace, E., Vilardell, F., Gómez, J. M., Colomé, J., Amiaux, J., Cara, C., Berthe, M., Moreau, V., Morgante, G., Malaguti, G., Alonso, G., Álvarez, J. P., Ollivier, M., Philippon, A., Hellin, M.-L., Roose, S., Frericks, M., Krijger, M., Rataj, M., Wawer, P., Skup, K., Sobiecki, M., Jessen, N. C., Pedersen, S. M., Hargrave, P., Griffin, M., Ottensamer, R., Hunt, T., Rust, D., Saleh, A., Winter, B., Focardi, M., Deppo, V. D., Zuppella, P., and Czapalla, M., “The ARIEL payload: A technical overview,” in [*Space Telescopes and Instrumentation 2020: Optical, Infrared, and Millimeter Wave*], Lystrup, M., Perrin, M. D., Batalha, N., Siegler, N., and Tong, E. C., eds., **11443**, International Society for Optics and Photonics, SPIE (2020).
- [7] Puig, L., Pilbratt, G., Ratti, F., Scharnberg, C., Boudin, N., Crouzet, P.-E., Halain, J.-P., Haag, M., Escudero, I., Bielawska, K., Kohley, R., Symonds, K., Renk, F., Findlay, R., Ertel, H., and Biesbroek, R., “The ESA Ariel mission is ready for implementation,” in [*Space Telescopes and Instrumentation 2020: Optical, Infrared, and Millimeter Wave*], Lystrup, M., Perrin, M. D., Batalha, N., Siegler, N., and Tong, E. C., eds., **11443**, 189 – 199, International Society for Optics and Photonics, SPIE (2020).
- [8] Naponiello, L., Noce, V., Focardi, M., Giorgio, A. M. D., Preti, G., Lorenzani, A., Tozzi, A., Vecchio, C. D., Farina, M., Galli, E., Morgante, G., Scippa, A., Redigonda, G., Giusi, G., Amiaux, J., Cara, C., Berthe, M., Ottensamer, R., Eccleston, P., Caldwell, A., Bishop, G., Desjonqueres, L., Drummond, R., Brienza, D., and Pace, E., “The role of the instrument control unit within the ARIEL Payload and its current design,” in [*Space Telescopes and Instrumentation 2020: Optical, Infrared, and Millimeter Wave*], Lystrup, M., Perrin, M. D., Batalha, N., Siegler, N., and Tong, E. C., eds., **11443**, 759 – 770, International Society for Optics and Photonics, SPIE (2020).