



Publication Year	2015
Acceptance in OA	2020-08-26T11:02:46Z
Title	Commissioning of ARGOS at LBT: adaptive optics procedures
Authors	BUSONI, LORENZO, BONAGLIA, MARCO, Borelli, Jose, Deysenroth, Matthias, ESPOSITO, Simone, Gaessler, Wolfgang, Gemperlien, H., Kulas, M., Lefebvre, M., Mazzoni, T., Organ de Xivry, G., Peter, D., PUGLISI, Alfio Timothy, Raab, W., Rabien, S., Rahmer, G., Sivitilli, A., Storm, J., Ziegleder, J.
Publisher's version (DOI)	10.20353/K3T4CP1131725
Handle	http://hdl.handle.net/20.500.12386/26834

UCLA

Adaptive Optics for Extremely Large Telescopes 4 - Conference Proceedings

Title

Commissioning of ARGOS at LBT: adaptive optics procedures

Permalink

<https://escholarship.org/uc/item/6js4k5m5>

Journal

Adaptive Optics for Extremely Large Telescopes 4 - Conference Proceedings, 1(1)

Authors

Busoni, Lorenzo
Bonaglia, Marco
Borelli, Jose
et al.

Publication Date

2015

DOI

10.20353/K3T4CP1131725

Peer reviewed

Commissioning of ARGOS at LBT: adaptive optics procedures

L. Busoni^a, M. Bonaglia^a, J. Borelli^c, M. Deysenroth^b, S. Esposito^a, W. Gaessler^c, H. Gemperlein^b, M. Kulas^c, M. Lefebvre^d, T. Mazzoni^a, G. Orban de Xivry^b, D. Peter^c, A. Puglisi^a, W. Raab^e, S. Rabien^b, G. Rahmer^d, A. Sivitilli^c, J. Storm^f, and J. Ziegleder^b

^aINAF Osservatorio Astrofisico di Arcetri, L.go E. Fermi 5, 50125 Firenze, Italy

^bMax Planck Institut für extraterrestrische Physik, Giessenbachstrasse 1, 85748, Garching, Germany

^cMax-Planck-Institut für Astronomie, Königstuhl 17, 69117 Heidelberg, Germany

^dLarge Binocular Telescope Observatory, Tucson, Arizona, USA

^eEuropean Space Agency, ESTEC Keplerlaan 1 2201AZ Noordwijk The Netherlands

^fLeibniz-Institut für Astrophysik, Postdam, Germany

ABSTRACT

ARGOS is the laser guide star facility of the Large Binocular Telescope (LBT). It implements a Rayleigh Laser Guide Star system that provides Ground Layer Adaptive Optics (GLAO) correction for the LUCIs, the 2 wide-field near-infrared imagers and multi-object spectrographs installed on the 2 eyes of LBT. In this paper we describe how LBT's adaptive optics operations have been tailored to ARGOS's use cases based on the experience developed during over the ARGOS commissioning. We focus on all the aspects that are influenced by the use of the Laser Guide Stars, from collimation to acquisition and LGS guiding and we details the sequences to start, pause and resume the adaptive correction.

Keywords: Ground Layer Adaptive Optics, Laser Guide Star, Large Binocular Telescope

1. INTRODUCTION

ARGOS^{1*} aims at realizing a uniform correction over the full field-of-view (FoV) of the LUCI,² a near-infrared imager and multi object spectrograph with a wide 4'x4' field, by means of a laser-assisted GLAO^{3,4} correction based on a tomographic sensing of the atmospheric turbulence realized through 3 Rayleigh Laser Guide Star (LGS) forming an asterism of 2' radius at 12 km altitude. The design and development of ARGOS subsystem has been described in the proceedings: the LGS Wave Front Sensor⁵⁻⁷ (LGSW), the Laser and Launch system,⁸⁻¹⁰ the control software.^{11,12}

ARGOS is currently in the commissioning phase, with first on-sky results obtained during 2015 that confirm the expected performances and anticipate the boost in LUCI's scientific return that will be made available once ARGOS will be released for science. For a complete description of ARGOS's first commissioning results see Ref. 13 in this proceedings.

The system has been designed to be suited for routine usage under most conditions both in term of hardware and control software, with the goal of having a reliable system operated automatically by the LUCI observing script, requiring a very limited intervention of a human operator. To make the best scientific use of the advantages generated by ARGOS a great care has been spent in minimizing the overheads related to the operational procedures of such a complex laser-assisted adaptive optics system. The telescope collimation, the acquisition of natural and lasers guide stars, the sequences to start the adaptive optics correction and performing dithering and offsets have been carefully designed and tested at the telescope, becoming a good fraction of the commissioning

Further author information: (Send correspondence to Lorenzo Busoni)

Lorenzo Busoni: E-mail: lbusoni@arcetri.astro.it, Telephone: +39 055 2752 202

*The Advanced Rayleigh Ground layer adaptive Optics System for the LBT

effort. The satellite and airplane avoidance system events, in spite of their asynchronous nature that make a synchronization with the observing sequence impossible, are automatically managed by the ARGOS control SW that reacts in a safe way while at the same time minimizing the impact on the observation.

In the next sections, after a summary of ARGOS main sub-units, we present the details of the ARGOS operating procedures, following the chronological order of a LUCI observation sequence, from collimation of the telescope to laser propagation, NGS and LGS acquisition and adaptive optics correction.

2. ARGOS AND OTHER LBT AO MODULES

ARGOS has been designed to fully exploit the functionality provided by the pre-existing active and adaptive optics modules of the LBT. In particular ARGOS relies on the Adaptive Secondary Mirror¹⁴(ASM) as adaptive corrector whose 672 actuators and optical conjugation at 150m above ground perfectly fit the needs of a GLAO system. The ASM electronics host a powerful real-time-computer (RTC) that can be used by every AO system at LBT for wavefront reconstruction: the RTC is based on Microgate’s Basic Computing Unit¹⁵ (BCU) and can be interfaced with ARGOS’s slope computer, also based on BCU, that also acts as frame grabber and assembles the full ARGOS slope vector that is sent to the ASM RTC.

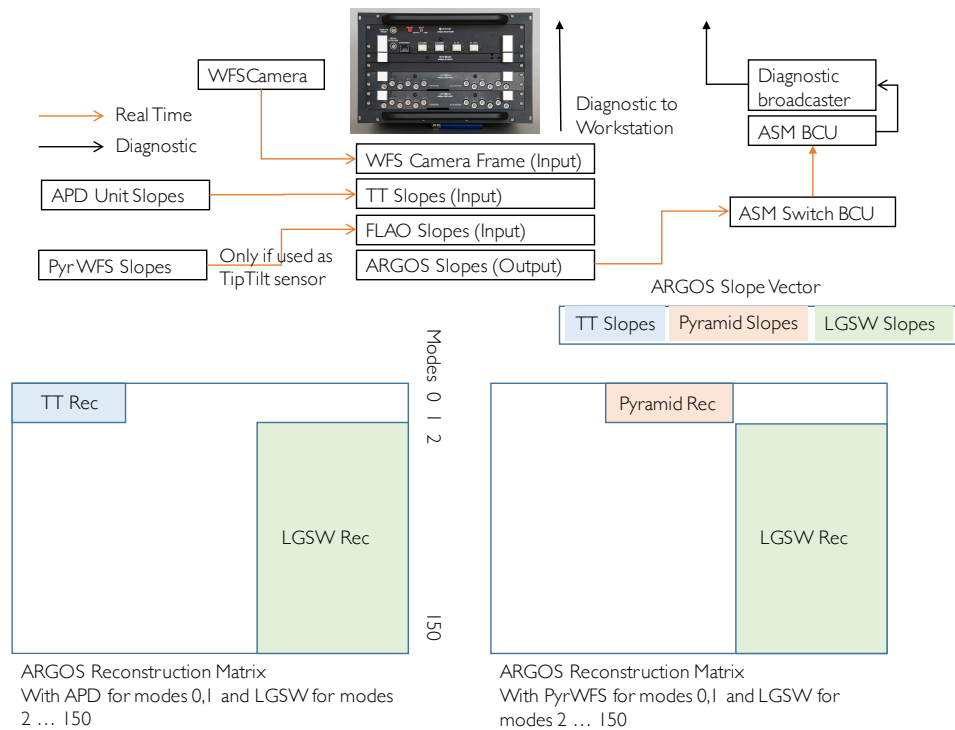

Figure 1. Scheme of the ARGOS real time communication link. The ARGOS BCU receives data from the LGS WFS camera and compute the LGSW signals. In the meanwhile, signals from the APD quad-cell unit and from the pyramid WFS may asynchronously be received and are copied together with the LGSW signals in the global ARGOS slopes vector that is transmitted to the ASM RTC BCU.

The ARGOS reconstructor matrix loaded into the RTC for modal wavefront reconstruction is a block-matrix obtained as a combination from the single reconstructors of the 3 WFSs: APD, Pyramid and LGSW. In the figure (bottom left) a scheme of the combined reconstructor for the baseline mode in which tip-tilt modes are controlled by the APD quad-cell sensor and the other modes are controlled by the LGSW. In the bottom right a similar scheme for the alternative mode in which the Pyramid WFS serves as tip-tilt sensor. Several other schemes are possible, including an LGSW-only mode and a mixed mode with tip-tilt controlled by the APD and a few low-order modes controlled by the FLAO before the LGSW modes.

ARGOS makes also use of the First Light Adaptive Optics system (FLAO) pyramid wavefront sensors^{16,17} for all the needs related to the natural guide star: the NGS board mounted on motorized stages is used to acquire the single ARGOS tip-tilt star on a $3' \times 2'$ FoV and it hosts a quad-cell tip-tilt sensor based on APDs specifically developed for ARGOS.¹ The FLAO pyramid WFS is also used as Truth Sensor: it receives 10% of the NGS flux to sense the residual wavefront aberrations close to LUCI and update the reference slopes of the LGSW. As a backup solution, the FLAO pyramid WFS can also be used to sense tip-tilt: a real-time fiber channel connects the FLAO BCU to the ARGOS BCU that asynchronously appends the tip-tilt slopes to the LGSW slope vector.

The real-time link diagram concerning Pyramid WFS, ARGOS and ASM is shown in Fig. 1, together with the typical scheme of reconstruction matrices for the 2 cases: tip-tilt sensed by the APD Quad Cell module (left) and tip-tilt sensed by the pyramid WFS module (right).

3. TELESCOPE COLLIMATION

In a seeing-limited LUCI observation the collimation of the telescope is performed by the active optics and guiding unit (AGW) that picks up the guiding star in a large semi-annular area around the LUCI field right before the LUCI entrance window; in the case of ARGOS-assisted observations, a dichroic window¹⁸ is slid in front of the LUCI focal station to reflect the laser guide star beams in the direction of the LGSW that sits on an optical bench aside the LUCI focal station (see Fig. 2 for the layout of the above described part of the system). Because of volume constraints and system economy the dichroic's size is not large enough to transmit entirely the large patrol field of the AGW that becomes vignetted by the dichroic mount. The consequence of this design choice is that, when the dichroic is deployed in the telescope optical path, the field available to pick-up the guiding and collimation star is reduced to the transmitted central field of $6.5'$ diameter. Only about half of this area is reachable by the AGW probe, most of which is actually overlapping LUCI field (see Fig. 2 right).

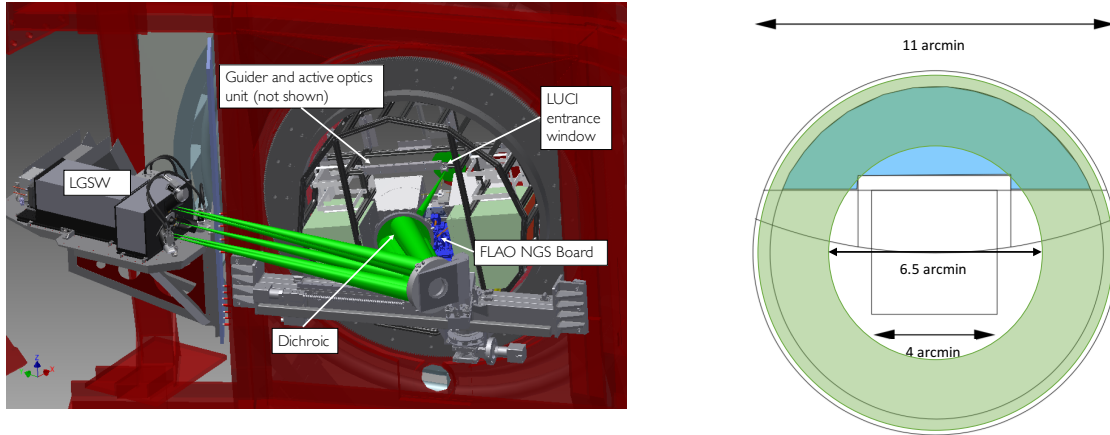

Figure 2. (left) View of the LUCI focal station from the primary mirror. The guiding and active optic unit (AGW, not shown in the model) occupies the empty volume in the circular structure above the the NGS pyramid WFS hardware. When the AGW probe is moved inside the LUCI field to collimate the telescope on an on-axis star it blocks both LUCI field and the NGS board patrol field.

(right) Shadowing of the AGW patrol field caused by the dichroic window. The dichroic transmits a $6.5'$ field while shadowing the annulus from 6.5 to $11'$ (green in the picture). The AGW probe can reach anywhere above the bow passing from the center, but the area available for guiding that doesn't vignette LUCI's field is only the blue shaded area. Only a tiny circular segment of 3 arcmin^2 can be used for guiding through the dichroic without vignetting LUCI's field.

In fact, an additional limitation that must be taken into account is that the AGW pick-up probe obviously vignettes the LUCI field when the collimation star is in the central $4'$ field. In summary only an area of about 3 arcmin^2 is available for guiding and collimation off-axis through the dichroic.

There are several choices to overcome the limitations caused by the use of ARGOS's dichroic and they will be briefly described in the following, together with the sequence that is so far considered the best one, based on time requirements and ease of integration with the current telescope control system (TCS).

One scheme at first foreseen consists in sliding the dichroic out of the beam during the phases of pointing and collimation of the telescope. Once the telescope is collimated the guider can be stopped, its probe can be removed and, while the telescope is in tracking mode, the dichroic can be inserted and adaptive optics operations can be initiated. As in the FLAO system, once the ARGOS adaptive loop is running, the adaptive optics system itself provides guiding and collimation information to the telescope via the offload of ASM static shape to the TCS so that the AGW is not needed anymore. The drawback of this scheme is the additional time required at each pointing to slide in and out the dichroic (about 1 minute in each direction).

A second scheme consists in having the dichroic always in the beam and in selecting a guiding and collimation star in the central 6.5' field behind the dichroic window. After the collimation is completed, the guider must be stopped and the AGW probe must be moved away to avoid the vignetting of the LUCI field. After that, the natural guide star for the adaptive optics can be acquired and adaptive optics operation are initiated. The disadvantage of this approach is the time needed to remove the guider probe (about 1 min) and the fact that removing the probe during the observing sequence is not currently automatically managed by the LBT TCS requiring manual coordination between the telescope operator and the LUCI operator.

A third scheme, currently chosen for ARGOS operation, consists in adding a dedicated preset to collimate the telescope on-axis through the dichroic on a bright pointing star in the proximity ($< 1^\circ$) of the scientific target. Such a star allows to quickly collimate the telescope, with the additional benefit of a simultaneous update of the telescope pointing model. After this preliminary step a new preset is sent to the telescope, that slews to the scientific target in tracking mode (moving the guider probe away from the LUCI field). Since the repointing is small the telescope collimation is preserved and adaptive optics operations can be immediately started. The additional time spent for slewing the telescope from the pointing star to the scientific target is < 1 min and the entire sequence can be fully automatized in the LUCI scripts resulting overall in a faster preset sequence than the ones described above.

4. LASER PROPAGATION

As soon as the telescope reaches the target position, the lasers can be propagated on sky. This sequence is divided in several steps, some of whom require manned control for safety reasons:¹⁹

1. Before the beginning of the night, the Laser and Launch systems are setup for observation and the lasers are set to nominal power with the propagation shutters closed.
2. All safety and satellite interlocks must be in "clear to propagate" state. The Satellite Avoidance System (SAS) checks for actual pointing of the telescope and prevents laser propagation if the telescope pointing differs more than 6 arcmin from the target previously communicated to the Space Command Laser Clearinghouse.
3. The laser officer requires clearance for propagation to the two airplane spotters via radio and wait for confirmation.
4. If all previous conditions are met, the laser officer open the propagation shutter and lasers are propagated on sky.

The typical time required to propagate the lasers on-sky is $\approx 2min$.

Next, a large field ($\sim 1^\circ$) Laser Alignment Telescope (LAT) that is copointed with the LBT is used to steer the lasers into the LGSW patrol cameras (that have a limited 40" field of view). The LAT images are analyzed to extract from the Rayleigh plume's intensity profiles the position of the asterism on sky. The difference vector between actual position and the target position is converted to commands for the tip-tilt motorized mirror (LM1) in the launch system to steer the asterism in the desired position. The accuracy of the extraction algorithm is good enough that in 1 or 2 iterations the lasers are captured in the LGSW patrol cameras.

4.1 Laser Beam shaping

Once the laser beams have been acquired in the LGSW patrol field an additional step to minimize the LGS spot size may be required. Of course the focus of the launch telescope must be adjusted in such a way that the image of the laser sources is formed in a plane conjugated to the LGSW focal plane. This is realized through a focus stage that moves axially the first lens of the launch telescope. See Fig. 3 for a schematic description of the launch system.

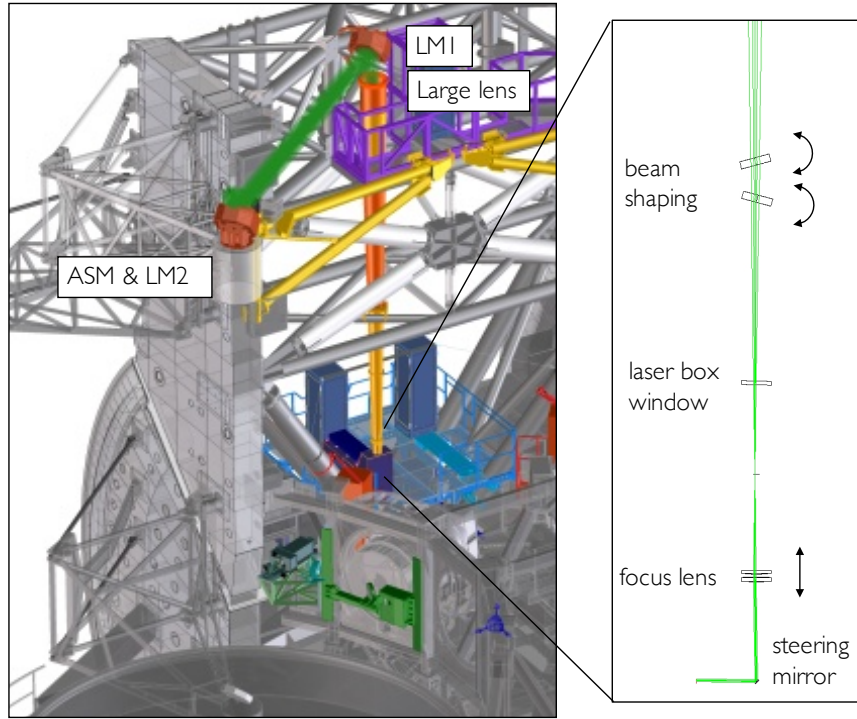

Figure 3. Inside the laser box, the 3 laser beams are recombined over a fast steering pupil mirror used to steer the asterism on sky and for vibration compensation¹⁰ that folds the beams upward. The refractive launch optics consists of 2 positive lenses. The first doublet lens is mounted on a motorized linear stage to adjust focus. The beam shaping device made of 2 counter-tilting parallel plates is installed in the diverging beam after the focus. After about 10m of free path, the beams encounter the second lens of the refractive launch telescope, a large flat mirror LM1 and a second large mirror LM2 installed on the back of the ASM that projects the 3 beams on sky. The LM1 is motorized for a coarse, wide range adjustment of the laser pointing.

Unfortunately the LGS spot shape is also largely determined by another effect: the thermal instability of the 2 large borosilicate flat mirrors (LM1 and LM2) working at 45° incidence angle in the launch optical path appears to be the cause of the spot elongation that appears a few minutes after laser propagation.¹³ A temperature controller has been installed to counter-heat the back surface of the mirror to stabilize the thermal gradient between the front and back surface of the mirrors; this device appears to limit the astigmatism to < 1 wave rms.

The residual astigmatism can be compensated with a beam-shaping device made of two counter-tilting windows mounted on a rotatory stage inserted in the diverging beam in the launch telescope. When the windows (12.5mm thick in a F/20 beam) are tilted they introduce astigmatism in the uplink path (up to 500nm rms when the angle of incidence on the windows is 50°). The rotatory stage is clocked until the PSF elongation due to the beam-shaper has the same direction of the thermally-induced elongation; since the orientation of astigmatism is not temperature-dependent but it rather depends only on the geometry of the mirrors, this clock adjustment is needed only once.

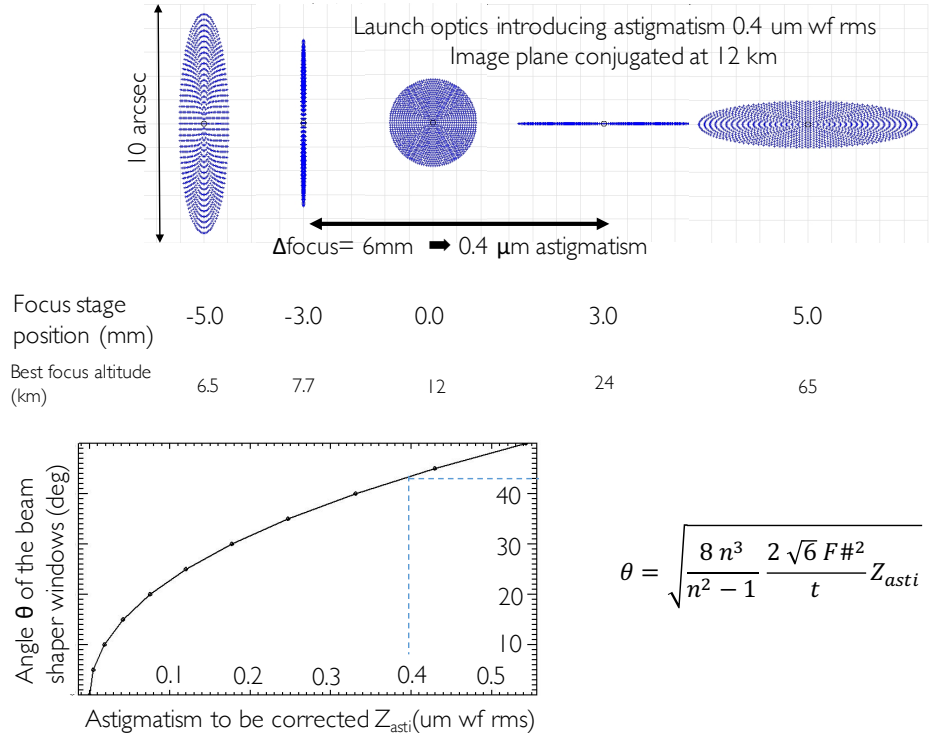

Figure 4. Measurement of a simulated astigmatism in the launch telescope. On top, the images of the launch beam as they would be registered by a device conjugated at 12km while the focus stage range is scanned in 5 steps. The procedure determines the 2 values of the focus stage that minimize the spot size along x and y direction (-3 and 3mm respectively). The difference $\Delta focus$ (6mm in the example) is linearly related to the wavefront astigmatism. The relation has been calibrated using the launch telescope optical model: $\Delta focus = 1mm$ when the beam astigmatism is 70nm rms. Once the astigmatism to be corrected is known, the required angle of incidence on the parallel plate windows of the beam shaping device can be computed according to the relation²⁰ shown in the bottom of the picture that relates the angle of incidence θ on the 2 windows of the beam-shaping device with the astigmatism Z_{asti} introduced by the device. t is the window thickness, n the refractive index and $F\#$ the f-number of the beam.

On the contrary, the amount of astigmatism that must be added to balance the thermal-induced astigmatism depends on the temperature gradient in the launch flat mirrors. To find the optimal value of the beam-shaping device a procedure is executed that consists in scanning the entire range of the focus stage while recording images of the laser spots on the patrol cameras in a kind of intra-focus/extra-focus sensor. For each focus stage position the spot size measured along the astigmatism direction and along the orthogonal one is saved. The distance between the minima is proportional to the total amount of astigmatism in the beam that is quantified using a model of the launch optics (see Fig. 4 for details of the technique and Fig. 5 for an example based on real data). This single focus-stage scan is enough to estimate both the beam-shaping best angle and the best position of the focus-stage.

This procedure is optional and, for the moment, supervised by the ARGOS operator. It requires about 2 minutes and it is most needed at the beginning of the night when thermal disequilibrium is most important.

5. ACQUISITION

After laser launching and beam sharpening the LGSs are ready for adaptive optics operations; the LGSs must be acquired and actively kept in the 4.5''FoV of the LGSW Shack-Hartmann sensor.

The position of the LGS spots in the patrol camera field is automatically or manually determined and the LM1 is again used to steer the beams inside the LGSW. Manned acquisition is at the moment preferred because

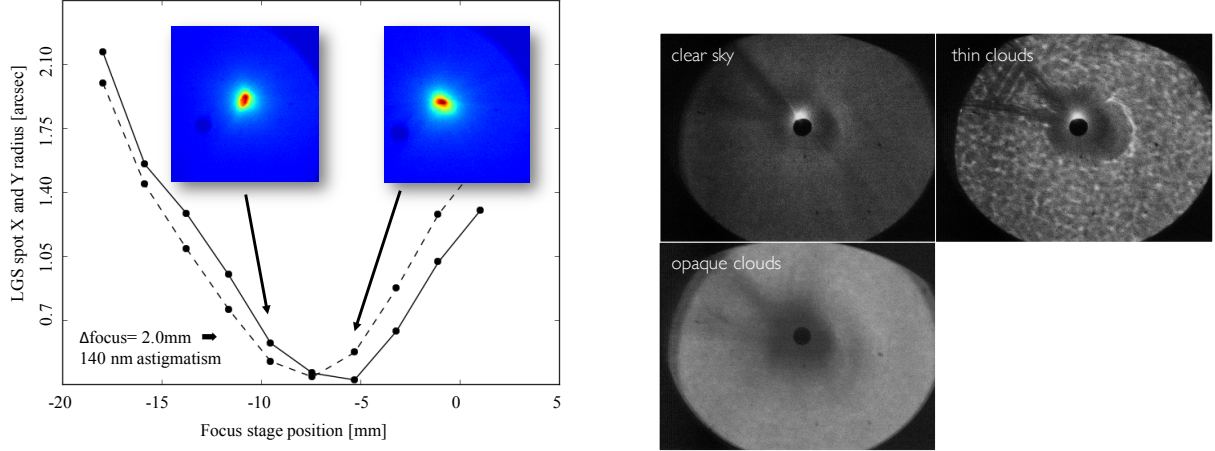

Figure 5. (Left) Example of measurement of astigmatism in the upward beam. Two patrol cameras images corresponding to intra and extra-focus cases are shown in the insets.

(Right) Examples of acquisition camera images for different levels of sky transparency.

it is an easy task for the ARGOS operator (it requires only to click in the 3 patrol camera images on the LGS spot that is always easily identified by the ARGOS operator) while making the acquisition procedure much more robust in case of thin clouds that creates scattering images on the patrol cameras field (see Fig. 5, right).

5.1 LGS Guiding

After LGSW acquisition an addition control thread is started to actively maintain the beams in the LGSW field. This is needed as the launching telescope accumulates a pointing drift with respect to the main telescope because of elevation-dependent mechanical flexures. The drifts are in the order of $1''/min$ so an active mechanism to measure them and correct the laser pointing on-sky is needed and is described in this section.

When the LGSs are in the LGSW field, the Shack-Hartmann sensor average flux per subaperture exceeds a threshold value of 125 photons/subap/ms (typical value in good sky condition is 900 photons/subap/ms) and the LGSW is declared in 'Acquired' state. This automatically enables an internal jitter compensation loop whose task is to null the LGS tilt on the SH sensor. As shown in Fig. 6, the jitter compensation makes use of a fast tip-tilt piezo mirror for each LGS beam to keep the spots on average centered in the SH subapertures. Note that the field stop at the entrance of the LGSW and the WFS camera are optically conjugated: in the case of an LGS pointing drift on sky that causes a shift of the LGS spot in the field stop, the jitter compensation loop will react by adjusting the piezo mirror position to null the tilt measured by the SH sensor. By applying a 1 Hz low-pass filtering to the piezo mirror positions to eliminate the contribution of atmospheric jitter and telescope vibrations we have a measure of the LGS pointing drift in the LGSW field stop [†].

The pointing drift is corrected by steering the asterism on sky with the steering mirror located in the launch telescope(see Fig. 3). This pupil mirror has the same optical effect of the LM1 but with different range and resolution: while the LM1 can correct for hundreds of arcsec but with a minimum step of $0.4''$, the pupil mirror has extremely high resolution but a limited range of $20''$ on-sky. So the LM1 is mainly used for acquisition, while the pupil mirror is the best device for correcting LGS pointing drift. To overcome its limited stroke that would drive it to saturation in a few minutes, the pupil mirror is periodically offloaded to the LM1 in maximum steps of $0.5''$.

[†]The piezo mirror position that conjugates the center of the field stop with the center of SH subapertures is measured in day-time with the calibration source: we scan the LGS spots across the LGSW field by moving the ASM hexapod so to accurately determine and position the LGS spots in the center of the field. We then close the jitter compensation loop to null the tilt on the SH sensor and we store the current piezo mirror position as 'target position'.

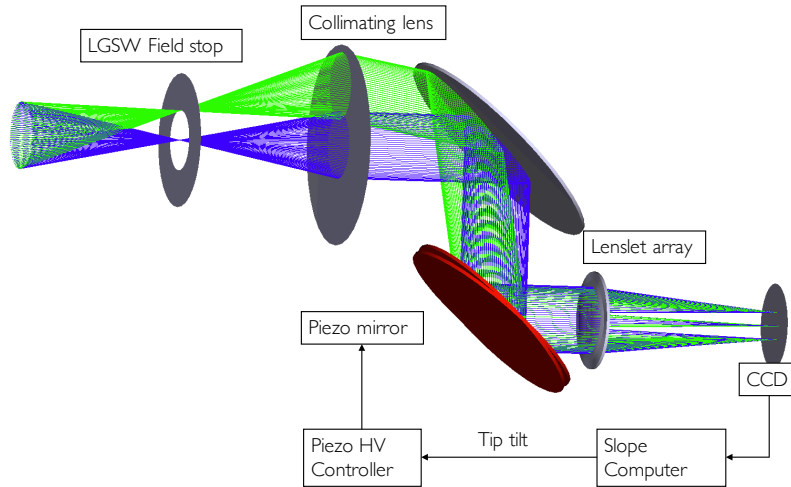

Figure 6. A simplified model of the LGSW optics (one LGSW beam only, not complete and not in scale) that shows the jitter compensation and the LGS guiding scheme. The LGS beam is re-centered on the CCD by the jitter compensation loop through a piezo steering mirror (in red)) that is fed with commands to null the laser beam tilt. The green beam shows the path of an LGS that has drifted in the LGSW field stop and requires to be repointed on sky to be recentered in the LGSW field. The pointing correction is proportional to the offset of the steering mirror with respect to the nominal working position (measured in the configuration of the blue beam).

5.2 NGS Acquisition

In parallel with the process of LGS acquisition, the NGS sensor is configured and the natural star chosen in the LUCI script as tip-tilt and truth sensing star is acquired. As the NGS subsystem is mostly based on FLAO’s hardware, the control software as well follows the scheme used in FLAO: when LUCI presets for a new observation, the TCS communicate to the ARGOS control SW the position of the natural star in the focal plane and its magnitude. The ARGOS control SW then moves the NGS board to the nominal position and in the meanwhile it configures, accordingly to a look-up table, the pyramid WFS camera (framerate, binning), the APD controller (framerate) and the filter wheels that split the visible light between the 2 arms of the NGS board. It also configures the BCU slope computer of the pyramid WFS, and the TruthSensor SW process. The NGS board is moved along the Z axis to the position, measured in day-time with the calibration source, that optimizes the sharpness on LUCI while nulling the focus term on the pyramid WFS.

After collimation is completed, the NGS appears in the 14'' field of the NGS technical viewer and the acquisition begins: the position of the star is automatically determined and the motorized stages supporting the NGS board are moved to fine-center the NGS on a previously determined target pixel of the tech-viewer. The NGS optical board has been internally aligned in the lab to ensure that in this condition the NGS will be imaged in the center of the APD quad-cell sensor.

6. ADAPTIVE OPTICS CONTROL LOOP

In this section we describe the sequence of operations followed to start the ground-layer adaptive correction.

1. **Configure Real Time Computer** The real-time computer scheme (see Fig. 1) is configured. The reconstructor matrix is selected accordingly to the chosen configuration (APD vs Pyramid, binning of pyramid WFS) and to the magnitude of the NGS. The reconstructor matrix is uploaded to the ASM RTC. The ARGOS slope computer BCU is re-configured, if needed.

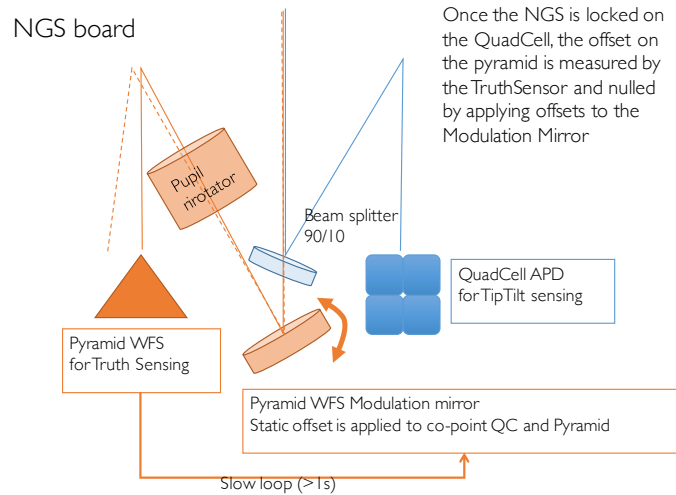

Figure 7. Sketch of the NGS copointing between APD tip-tilt sensor and pyramid WFS.

2. **Close Tip-Tilt loop** The real time communication between the slope computer and the reconstructor on the ASM is enabled, with all modal gains set to zero. Tip-tilt gains are ramped up from 0.01 to 0.2 in a few seconds. When the tip-tilt loop is optically closed, the ASM will slightly tilt to lock the star in the center of the tip-tilt sensor; the amplitude of this movement will be a fraction of the tip-tilt sensor field of view and depends on the centering accuracy obtained during the NGS acquisition (a typical value being $0.5''$). Because of this effect, the LGS asterism is also displaced by the same amount in the LGSW field and may result in temporary loss of flux from the SH sensor. For this reason we let the system stabilize for a few seconds, waiting until the LGS guider has converged again.
3. **Copoint Tip-Tilt and Truth Sensors** A small ($< 1''$) residual mis-pointing between APD and pyramid WFS can still be present and must be corrected to permit to the pyramid WFS to work as truth sensor in optimal condition. The pyramid WFS itself provides the information about the mis-pointing in the form of tip and tilt modal coefficients that are translated into static offsets to the modulating mirror (see Fig. 7). Since the copointing is slightly affected by the pupil re-rotator angle which is continuously changing during observation, the copointing algorithm is kept running in a slow loop as long as the tip-tilt adaptive correction is enabled.
4. **Offload Focus to Time-Of-Flight** To avoid introducing all of a sudden a too large focus command when the LGS loop is closed, we first make sure that the focus term measured by the SH sensor is small. This is realized by changing the altitude to which the LGSW is conjugated by modifying the time-of-flight, i.e. the time passing between the laser pulse and the moment in which the gating units in the LGSW are opened. This interval, that is nominally $84\mu\text{sec}$ corresponding to the round-trip of the laser beacon to 12km altitude, is adjusted to null the focus term measured by the SH WFS. This ensures a smooth operation when the LGS loop is closed.
5. **Close LGS loop** The gain of the modes controlled by the LGS are increased in steps from 0.001 to 0.1 in a few seconds.
6. **Start Truth Sensing** The truth sensor loop is enabled. The FLAO control SW computes autonomously the “true” wavefront error projected on the same modal basis that is used in ARGOS for the adaptive correction. The modal coefficients are read by the ARGOS control SW and converted in LGS WFS signals through a multiplication by the LGS interaction matrix. This signal vector is integrated to the current

LGSW slope-offset vector for all modes but the focus. Focus is offloaded to the time-of-flight, as described above, to retain the maximum dynamical range of the SH sensor.

7. **Optimize modal gains** As a last step, the modal gains can be optimized. An optimization script that scans a range of modal gains and search for the values that minimize the WFS signal variance can be optionally executed. The operator has anyhow the possibility of tweaking the values of the modal gains (grouped in 3 sets: tip-tilt, modes from 2 to 36, and higher modes) from the ARGOS control GUI. This procedure is not always required for the modes controlled by the LGSW, because the sensitivity of the SH sensor is stable enough under all operating conditions. At the contrary, it is always required for tip and tilt modes because the quad-cell sensor (and the pyramid WFS too, when it is used instead of the quad-cell sensor) sensitivity depends on PSF size that, in turn, depends on seeing.

At the end of this sequence, that requires about 1 minute, the LUCI integration begins.

6.1 Dithering, offsets and asynchronous interruptions

During the execution of a LUCI observing block, there are several circumstances that require to pause the adaptive correction for a short period. These include offsetting the field (and the size of the offset plays a role in the way the offset is realized) and stopping the laser propagation because of satellite or airplane transit.

In the case of small offsets ($< 15''$, to be extended in the future) the lasers propagation is not interrupted; since the launch telescope is integral with the telescope mount, the LGS spots remain centered in the LGSW field and there is no need to pause the LGS adaptive loop. The NGS loop, at the contrary, is paused by setting the gains of the NGS controlled modes to zero. The NGS board stages are then offset to recenter the NGS star on the tip-tilt sensor and the NGS loop is then resumed by ramping up in 2 steps the gain of the NGS modes to the original value. During the offset, the truth sensing is disabled.

In the case of larger offsets ($> 15''$) the laser propagation is briefly interrupted and resumed when the slew is terminated. In this case of course LGS loop is paused (by setting LGS modal gains to 0) together with the NGS and resumed when the lasers are back on sky. For even larger offsets, the NGS star cannot be reacquired because it is outside of the field reachable by the motorized stages of the NGS board ($3' \times 2'$) and the adaptive loop simply remains paused for all NGS and LGS modes. When the telescope will be offset back and the NGS star will be again in a region reachable by the NGS board, then the adaptive optics loop will be resumed.

When a satellite or an airplane transit requires to stop laser propagation, the control SW attempts to automatically pause the LGS loop and then stops the lasers: this ensures a safe reaction, and permits a fast resume of the closed-loop observation as soon as the lasers are propagated again on sky without the overhead of a new acquisition. For the moment the loop is resumed manually, leaving to the ARGOS operator the freedom to decide if reacquiring the LGSs, that during the pause may have drift out of the field.

In the current TCS control scheme there is no way for ARGOS to interact with the LUCI script sequencer that is then unaware about these kind of events and cannot react and optimize the observation. A quantitative analysis of the fraction of observing time spent in open-loop because of satellite/airplane events is still to be done, but at a first glance it seems to have a minor impact on the overall efficiency.

7. CONCLUSION

A large effort is being spent during the commissioning in optimizing the adaptive optics operations to minimize overheads and maximize the scientific return of ARGOS. We have shown here that the current sequence is able to setup the system in an automatic way that appears to be safe, reliable and fast. The overhead due to ARGOS, to be summed to the typical timing of seeing-limited operation, is evaluated in about 1 min for collimation, 5 min for laser propagation, beam shape optimization and acquisition and < 1 min for starting adaptive optics.

ACKNOWLEDGMENTS

The authors wish to thank the entire LBT telescope crew, telescope managers and telescope operators for their continuous support and dedication to the ARGOS project. A very warm thank you to all the airplanes spotters standing cold Mt Graham nights.

REFERENCES

- [1] Rabien, S., Barl, L., Beckmann, U., Bonaglia, M., Borelli, J. L., Brynnel, J., Buschkamp, P., Busoni, L., Christou, J., Connot, C., Davies, R., Deysenroth, M., Esposito, S., Gässler, W., Gemperlein, H., Hart, M., Kulas, M., Lefebvre, M., Lehmitz, M., Mazzoni, T., Nussbaum, E., Orban de Xivry, G., Peter, D., Quirrenbach, A., Raab, W., Rahmer, G., Storm, J., and Ziegleder, J., “Status of the ARGOS project,” in [*Society of Photo-Optical Instrumentation Engineers (SPIE) Conference Series*], *Society of Photo-Optical Instrumentation Engineers (SPIE) Conference Series* **9148**, 91481B (July 2014).
- [2] Buschkamp, P., Seifert, W., Polsterer, K., Hofmann, R., Gemperlein, H., Lederer, R., Lehmitz, M., Naranjo, V., Ageorges, N., Kurk, J., Eisenhauer, F., Rabien, S., Honsberg, M., and Genzel, R., “LUCI in the sky: performance and lessons learned in the first two years of near-infrared multi-object spectroscopy at the LBT,” in [*Society of Photo-Optical Instrumentation Engineers (SPIE) Conference Series*], *Society of Photo-Optical Instrumentation Engineers (SPIE) Conference Series* **8446**, 84465L (Sept. 2012).
- [3] Rigaut, F., “Ground Conjugate Wide Field Adaptive Optics for the ELTs,” in [*European Southern Observatory Conference and Workshop Proceedings*], Vernet, E., Ragazzoni, R., Esposito, S., and Hubin, N., eds., *European Southern Observatory Conference and Workshop Proceedings* **58**, 11 (2002).
- [4] Tokovinin, A., “Seeing improvement with groundlayer adaptive optics,” *Publications of the Astronomical Society of the Pacific* **116**(824), 941–951 (2004).
- [5] Busoni, L., Bonaglia, M., Esposito, S., Carbonaro, L., and Rabien, S., “Final design of the wavefront sensor unit for ARGOS, the LBT’s LGS facility,” in [*Adaptive Optics Systems II*], *Society of Photo-Optical Instrumentation Engineers (SPIE) Conference Series* **7736**, 77365K (July 2010).
- [6] Orban de Xivry, G., Bonaglia, M., Borelli, J., Busoni, L., Connot, C., Esposito, S., Gaessler, W., Kulas, M., Mazzoni, T., Puglisi, A., Rabien, S., Storm, J., and Ziegleder, J., “ARGOS wavefront sensing: from detection to correction,” in [*Society of Photo-Optical Instrumentation Engineers (SPIE) Conference Series*], *Society of Photo-Optical Instrumentation Engineers (SPIE) Conference Series* **9148**, 914834 (Aug. 2014).
- [7] Bonaglia, M., Busoni, L., Mazzoni, T., Puglisi, A., Antichi, J., Esposito, S., Orban de Xivry, G., and Rabien, S., “Pre-shipment test of the ARGOS laser guide star wavefront sensor,” in [*Society of Photo-Optical Instrumentation Engineers (SPIE) Conference Series*], *Society of Photo-Optical Instrumentation Engineers (SPIE) Conference Series* **9148**, 91485G (Aug. 2014).
- [8] Raab, W., Rabien, S., Gässler, W., Esposito, S., Barl, L., Borelli, J., Daysenroth, M., Gemperlein, H., Kulas, M., and Ziegleder, J., “The ARGOS laser system: green light for ground layer adaptive optics at the LBT,” in [*Society of Photo-Optical Instrumentation Engineers (SPIE) Conference Series*], *Society of Photo-Optical Instrumentation Engineers (SPIE) Conference Series* **9148**, 91483K (July 2014).
- [9] Deysenroth, M., Honsberg, M., Gemperlein, H., Ziegleder, J., Raab, W., Rabien, S., Barl, L., Gässler, W., and Borelli, J. L., “ARGOS laser system mechanical design,” in [*Society of Photo-Optical Instrumentation Engineers (SPIE) Conference Series*], *Society of Photo-Optical Instrumentation Engineers (SPIE) Conference Series* **9148**, 91483H (July 2014).
- [10] Peter, D., Gässler, W., Borelli, J., Barl, L., and Rabien, S., “Vibration control for the ARGOS laser launch path,” in [*Society of Photo-Optical Instrumentation Engineers (SPIE) Conference Series*], *Society of Photo-Optical Instrumentation Engineers (SPIE) Conference Series* **8447**, 84474J (July 2012).
- [11] Kulas, M., Borelli, J. L., Gässler, W., Peter, D., Rabien, S., Orban de Xivry, G., Busoni, L., Bonaglia, M., Mazzoni, T., and Rahmer, G., “Practical experience with test-driven development during commissioning of the multi-star AO system ARGOS,” in [*Society of Photo-Optical Instrumentation Engineers (SPIE) Conference Series*], *Society of Photo-Optical Instrumentation Engineers (SPIE) Conference Series* **9152**, 91520D (July 2014).
- [12] Borelli, J., Barl, L., Gässler, W., Kulas, M., and Rabien, S., “Service-oriented architecture for the ARGOS instrument control software,” in [*Society of Photo-Optical Instrumentation Engineers (SPIE) Conference Series*], *Society of Photo-Optical Instrumentation Engineers (SPIE) Conference Series* **8451**, 84510G (Sept. 2012).
- [13] Orban de Xivry, G. e. a., “First Results of the Ground Layer Adaptive Optics System ARGOS,” in [*This proceedings*], (2016).

- [14] Riccardi, A., Xompero, M., Briguglio, R., Quirós-Pacheco, F., Busoni, L., Fini, L., Puglisi, A., Esposito, S., Arcidiacono, C., Pinna, E., Ranfagni, P., Salinari, P., Brusa, G., Demers, R., Biasi, R., and Gallieni, D., “The adaptive secondary mirror for the Large Binocular Telescope: optical acceptance test and preliminary on-sky commissioning results,” in [*Society of Photo-Optical Instrumentation Engineers (SPIE) Conference Series*], *Society of Photo-Optical Instrumentation Engineers (SPIE) Conference Series* **7736**, 77362C (July 2010).
- [15] Biasi, R., Andrighettoni, M., Riccardi, A., Biliotti, V., Fini, L., Mantegazza, P., and Gallieni, D., “Dedicated flexible electronics for adaptive secondary control,” in [*Advancements in Adaptive Optics*], Bonaccini Calia, D., Ellerbroek, B. L., and Ragazzoni, R., eds., *Society of Photo-Optical Instrumentation Engineers (SPIE) Conference Series* **5490**, 1502–1513 (Oct. 2004).
- [16] Esposito, S., Riccardi, A., Pinna, E., Puglisi, A. T., Quirós-Pacheco, F., Arcidiacono, C., Xompero, M., Briguglio, R., Busoni, L., Fini, L., Argomedo, J., Gherardi, A., Agapito, G., Brusa, G., Miller, D. L., Guerra Ramon, J. C., Boutsia, K., and Stefanini, P., “Natural guide star adaptive optics systems at LBT: FLAO commissioning and science operations status,” in [*Society of Photo-Optical Instrumentation Engineers (SPIE) Conference Series*], *Society of Photo-Optical Instrumentation Engineers (SPIE) Conference Series* **8447**, 84470U (July 2012).
- [17] Quirós-Pacheco, F., Busoni, L., Agapito, G., Esposito, S., Pinna, E., Puglisi, A., and Riccardi, A., “First light AO (FLAO) system for LBT: performance analysis and optimization,” in [*Adaptive Optics Systems II*], *Society of Photo-Optical Instrumentation Engineers (SPIE) Conference Series* **7736**, 77363H (July 2010).
- [18] Busoni, L., Bonaglia, M., Carbonaro, L., Mazzoni, T., Antichi, J., Esposito, S., Orban De Xivry, G., and Rabien, S., “Integration and laboratory characterization of the ARGOS laser guide star wavefront sensors,” in [*Proceedings of the Third AO4ELT Conference*], Esposito, S. and Fini, L., eds., 92 (Dec. 2013).
- [19] Rahmer, G., Lefebvre, M., Christou, J., Raab, W., Rabien, S., Ziegleder, J., Borelli, J. L., and Gässler, W., “Early laser operations at the Large Binocular Telescope Observatory,” in [*Society of Photo-Optical Instrumentation Engineers (SPIE) Conference Series*], *Society of Photo-Optical Instrumentation Engineers (SPIE) Conference Series* **9149**, 91492A (Aug. 2014).
- [20] Wyant, J. C. and Creath, K., “Basic Wavefront Aberration Theory for Optical Metrology,” in [*Applied Optics and Optical Engineering, Volume XI*], Shannon, R. R. and Wyant, J. C., eds., **11**, 2 (1992).