



Publication Year	2018
Acceptance in OA	2021-02-26T12:18:01Z
Title	The DREAMS experiment flown on the ExoMars 2016 mission for the study of Martian environment during the dust storm season
Authors	Bettanini, C., ESPOSITO, Francesca, Debei, S., MOLFESE, CESARE, Colombatti, G., Aboudan, A., BRUCATO, John Robert, CORTECCHIA, Fausto, DI ACHILLE, Gaetano, Guizzo, G. P., Friso, E., Ferri, F., MARTY, Laurent, MENNELLA, Vito, MOLINARO, Roberto, SCHIPANI, Pietro, Silvestro, Simone, Mugnuolo, R., Pirrotta, S., Marchetti, E., POPA, IONUT CIPRIAN, International Dreams Team
Publisher's version (DOI)	10.1016/j.measurement.2018.01.019
Handle	http://hdl.handle.net/20.500.12386/30647
Journal	MEASUREMENT
Volume	122



ELSEVIER

Contents lists available at ScienceDirect

Measurement

journal homepage: www.elsevier.com/locate/measurement

The DREAMS experiment flown on the ExoMars 2016 mission for the study of Martian environment during the dust storm season

C. Bettanini^{a,*}, F. Esposito^b, S. Debei^a, C. Molfese^b, G. Colombatti^a, A. Aboudan^a, J.R. Brucato^c, F. Cortecchia^b, G. Di Achille^b, G.P. Guizzo^a, E. Friso^a, F. Ferri^a, L. Marty^b, V. Mennella^b, R. Molinaro^b, P. Schipani^b, S. Silvestro^b, R. Mugnuolo^d, S. Pirrotta^d, E. Marchetti^d, , The International DREAMS Team, A.-M. Harri^e, F. Montmessin^f, C. Wilson^g, I. Arruego Rodríguez^h, S. Abbaki^f, V. Apestigue^h, G. Bellucciⁱ, J.-J. Berthelier^f, S.B. Calcutt^g, F. Forget^j, M. Genzer^e, P. Gilbert^f, H. Haukka^e, J.J. Jiménez^h, S. Jiménez^k, J.-L. Josset^l, O. Karatekin^m, G. Landisⁿ, R. Lorenz^o, J. Martinez^h, D. Möhlmann^p, D. Moirin^f, E. Palombaⁱ, M. Patel^q, J.-P. Pommereau^f, C.I. Popa^x, S. Rafkin^r, P. Rannou^s, N.O. Renno^t, W. Schmidt^e, F. Simoes^u, A. Spiga^j, F. Valero^v, L. Vázquez^v, F. Vivat^f, O. Witasse^w

^a CISAS “G.Colombo”, Università degli Studi di Padova, Padova, Italy

^b INAF – Osservatorio Astronomico di Capodimonte, Napoli, Italy

^c INAF-Osservatorio Astrofisico di Arcetri, Firenze, Italy

^d Italian Space Agency, Roma, Italy

^e Finnish Meteorological Institute (FMI), Helsinki, Finland

^f LATMOS – CNRS/UVSQ/IPSL, France

^g Oxford University, Oxford, United Kingdom

^h INTA, Spain

ⁱ INAF – Istituto di Fisica dello Spazio Interplanetario (IFSI), Italy

^j CNRS, LMD, France

^k Universidad Politécnica de Madrid, Spain

^l Space Exploration Institute, Switzerland

^m Royal Observatory of Belgium, Belgium

ⁿ NASA, GRC, USA

^o JHU Applied Physics Lab (JHU-APL), USA

^p DLR PF Leitungsbereich, Berlin, Germany

^q Open University, UK

^r SwRL, Switzerland

^s GSMA, France

^t University of Michigan, USA

^u NASA, GSFC, USA

^v Universidad Complutense de Madrid (UCM), Spain

^w ESA-ESTEC, Noordwijk, The Netherlands

^x INAF – Osservatorio Astronomico di Capodimonte, Napoli, Italy

ARTICLE INFO

Keywords:

Mars in situ analysis

Mars dust storm

Autonomous instrument

Atmospheric measurements on Mars

Electric phenomena characterization

ExoMars2016 mission

ABSTRACT

The DREAMS (Dust characterization, Risk assessment and Environment Analyser on the Martian Surface) instrument on Schiaparelli lander of ExoMars 2016 mission was an autonomous meteorological station designed to completely characterize the Martian atmosphere on surface, acquiring data not only on temperature, pressure, humidity, wind speed and its direction, but also on solar irradiance, dust opacity and atmospheric electrification; this comprehensive set of parameters would assist the quantification of risks and hazards for future manned exploration missions mainly related to the presence of airborne dust.

Schiaparelli landing on Mars was in fact scheduled during the foreseen dust storm season (October 2016 in Meridiani Planum) allowing DREAMS to directly measure the characteristics of such extremely harsh environment.

* Corresponding author.

E-mail address: carlo.bettanini@unipd.it (C. Bettanini).

<https://doi.org/10.1016/j.measurement.2018.01.019>

Received 21 November 2017; Received in revised form 10 January 2018; Accepted 11 January 2018

Available online 01 February 2018

0263-2241/ © 2018 Elsevier Ltd. All rights reserved.

DREAMS instrument's architecture was based on a modular design developing custom boards for analog and digital channel conditioning, power distribution, on board data handling and communication with the lander. The boards, connected through a common backbone, were hosted in a central electronic unit assembly and connected to the external sensors with dedicated harness. Designed with very limited mass and an optimized energy consumption, DREAMS was successfully tested to operate autonomously, relying on its own power supply, for at least two Martian days (sols) after landing on the planet.

A total of three flight models were fully qualified before launch through an extensive test campaign comprising electrical and functional testing, EMC verification and mechanical and thermal vacuum cycling; furthermore following the requirements for planetary protection, contamination control activities and assay sampling were conducted before model delivery for final integration on spacecraft.

During the six months cruise to Mars following the successful launch of ExoMars on 14th March 2016, periodic check outs were conducted to verify instrument health check and update mission timelines for operation. Elaboration of housekeeping data showed that the behaviour of the whole instrument was nominal during the whole cruise. Unfortunately DREAMS was not able to operate on the surface of Mars, due to the known guidance anomaly during the descent that caused Schiaparelli to crash at landing.

The adverse sequence of events at 4 km altitude anyway triggered the transition of the lander in surface operative mode, commanding switch on the DREAMS instrument, which was therefore able to correctly power on and send back housekeeping data. This proved the nominal performance of all DREAMS hardware before touchdown demonstrating the highest TRL of the unit for future missions.

The spare models of DREAMS are currently in use at university premises for the development of autonomous units to be used in cubesat mission and in probes for stratospheric balloons launches in collaboration with Italian Space Agency.

1. Introduction

Although a complete mapping of planetary atmosphere can be achieved only with instruments on orbiting spacecrafts [4], in situ analysis may provide a continuous and generally more accurate measurement of the surrounding local environment. Since the first robotic missions to Mars in fact special attention has been given to the accurate analysis of the atmosphere parameters and its variation during the day in order to develop optimised circulation models [3]. The first in situ data on Mars atmosphere trace back to the Viking missions [1,2]; more recent mission like Mars Exploration Rovers [5] and MSL [8,12] provided more accurate data on several atmospheric parameters integrating them with spectroscopy data.

To integrate available data and in the view of better understanding Mars environment for future manned exploration the European Space Agency developed the ExoMars programme, which foresaw two missions: the first mission, to be launched in 2016, consisted in an Orbiter plus an Entry, descent and landing Demonstrator Module (EDM); the second one, with a launch date within 2020, will include a planetary rover, equipped with a drill and a suite of instruments dedicated to exobiology and geochemistry research. The programme aims to demonstrate several essential flight and in-situ enabling technologies that are necessary for future exploration missions, such as an international Mars Sample Return mission. These technologies include: entry, descent and landing of a payload on the surface of Mars, surface mobility with a rover, access to the subsurface to acquire samples and sample acquisition, preparation, distribution and analysis.

The ExoMars 2016 Orbiter hosts scientific instruments to detect and study atmospheric trace gases, such as methane while the EDM was equipped with internal sensors to reconstruct attitude, trajectory and thermal profiles during the descent phase (AMELIA experiment [16]) relying on expertise built on previous planetary probes data analysis [6,7].

EDM also carried a sensor suite fully dedicated to study the environment at the landing site called DREAMS (Dust characterization, Risk assessment and Environment Analyser on the Martian Surface). A three dimensional impression of the EDM central bay where DREAMS is located is given in Fig. 1.

DREAMS was specially designed to conduct scientific measurements during the statistical dust storm season and to characterize the Martian environment in this dust loaded scenario. Airborne dust presents in fact a potentially significant risk to human operations on the surface of Mars, not only for dust intrusion and accumulation but also for the

abrasion effect generated by winds and the potential electrification of dust particles. Atmospheric transport and suspension of dust in fact frequently brings electrification and electric fields of $10\text{--}100\text{ kV m}^{-1}$ have been observed at the surface beneath suspended dust in the terrestrial atmosphere. Modelled profiles of electrical conductivity in the Martian atmosphere suggest the possibility of dust electrification, and dust devils have been suggested as a mechanism of charge separation able to maintain current flow between one region of the atmosphere and another, through a global circuit [17].

Once on the planetary surface DREAMS would operate on pre designed acquisition timelines monitoring pressure (DREAMS-P), temperature (MarsTem), wind speed and direction (MetWind), humidity (DREAMS-H), dust opacity (SIS) and investigate atmospheric electric phenomena with the MicroAres experiment.

The obtained data would allow the characterization of the Martian boundary layer in dusty conditions and help the identification of hazard conditions for equipments and human crew by providing a comprehensive dataset on: velocity of windblown dust, electrostatic charging, existence of discharges, intensity of UV radiation and E.M. noise potentially affecting communications.

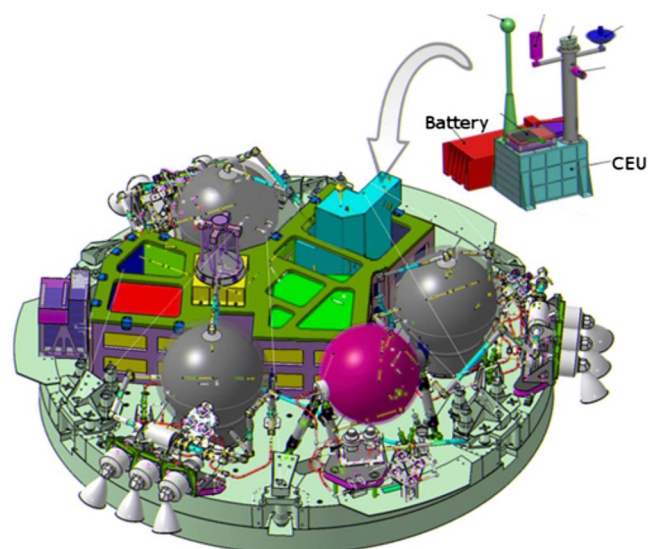

Fig. 1. DREAMS experiment position on board Exomars EDM landing platform.

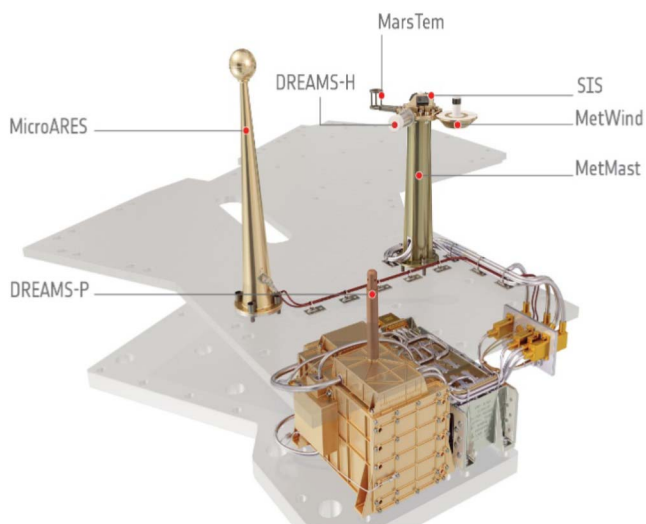

Fig. 2. 3D impression of DREAMS instrument installed on the EDM central bay, showing external sensors, central electronic unit, battery and interconnecting harness.

DREAMS was the result of an international joint effort with hardware contribution from Italy, Finland, United Kingdom, France and Spain.

2. DREAMS instrument

DREAMS instrument was a completely autonomous sensor suite constituted by the following subsystems: the Central Electronic Unit (CEU) comprising all electronic boards for sensor condition, data acquisition and communication with EDM, the Power Unit, a space qualified rechargeable battery assembly developed by ABSL), the Metmast

Assembly which hosted most of the external sensor and the micorAres electrode. DREAMS was installed on the upper part of the EDM landing platform: main electronics and the battery were accommodated inside the EDM central bay in a protected and temperature controlled environment, while external masts and pressure inlet tube would be in direct contact with Mars atmosphere. A dedicated harness provided the connection of DREAMS hardware located in the internal bay with the external sensing units and the EDM control unit through a connector bracket which separated the internal compartment with the external environment (Fig. 2).

Since DREAMS comprised both analog and digital sensors, proximity electronic units were provided for handling digital units.

2.1. Central Electronic Unit (CEU)

The CEU (Central Electronic Unit) is a modular equipment designed to provide all primary functionalities needed for operation, data acquisition and communication as timeline-based environmental operative sequences, analog to digital conversion for the analog environment sensors, power transformation and supply for all sensors/conditioners. It also performs data compression to meet the requirements on data volume budget for the ExoMars mission and realises data packetization for telemetry transfer to the EDM on board computer using non-volatile mass memory for data storage. The CEU is also able to execute self-testing thanks to its housekeeping data and sensors.

Thanks to a common backplane and a plug-in design, CEU was developed splitting functionalities into different boards (as reported in Fig. 3):

- OBDB Board implements the control layer of the CEU: stores and applies the Data Acquisition Timelines, interprets and forwards the telecommands coming from EDM to the peripheral boards (including data on power source use), collects the house keeping data

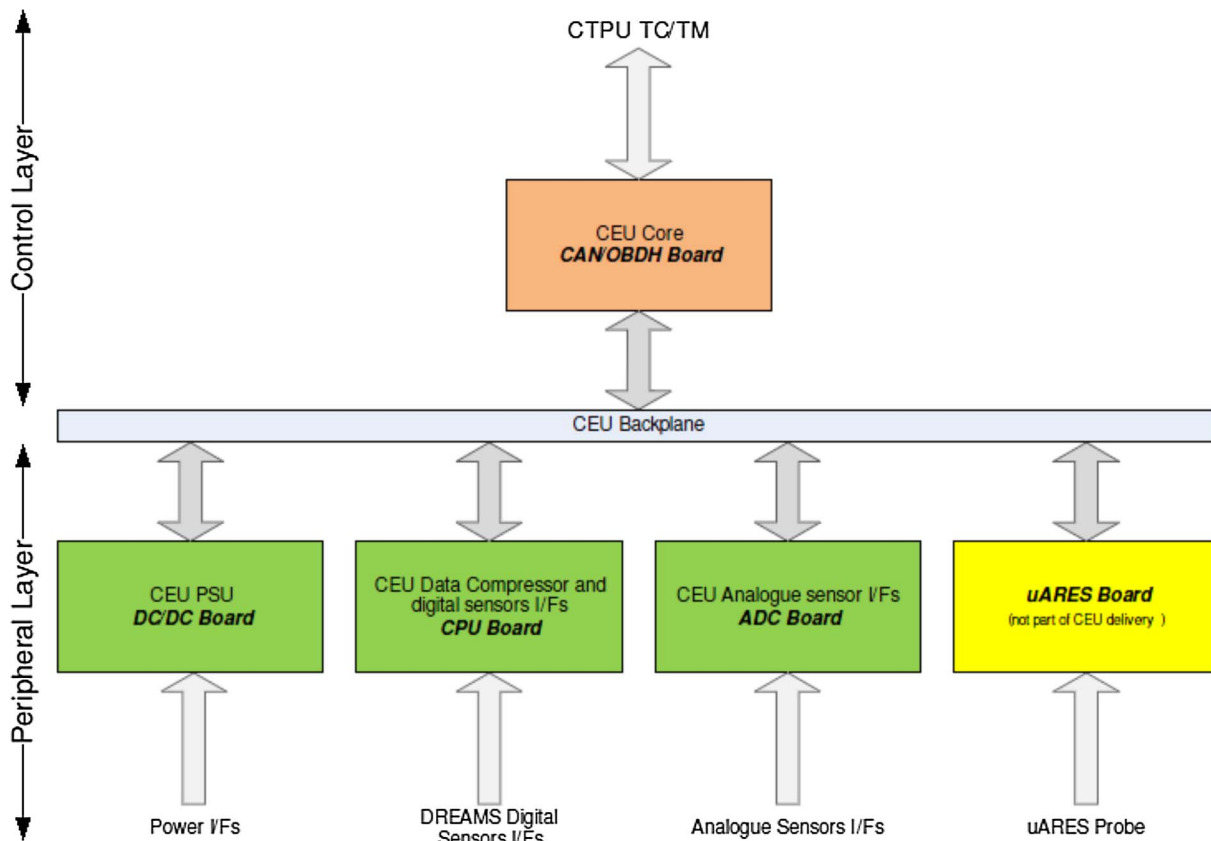

Fig. 3. Layers implemented in CEU architecture.

and retrieves the telemetries of the sensors, transferring the data back to the EDM for transmission to relay orbiter and then back to Earth.

- DC/DC Board performs the selection of the power supply source and powers all the CEU boards according to the profile of every mission phase.
- CPU Board compresses high volume data with dedicated algorithms depending on specific structure of data packets. This board also incorporates all the physical layers of the interfaces towards the μ ARES board and DREAMS P/H sensor.
- μ ARES Board is integrated in a dedicated slot of CEU, that performs the control of power and data handling of the μ ARES sensor.
- ADC Board performs conditioning and acquisition of signals of analog sensors depending on operative timelines. The collected data are transferred to the OBDH Board for storage and transmission.

All boards were custom designed, developed and tested within a collaboration with TEMIS, an Italian company specialised in custom electronics development

2.2. Power unit

DREAMS battery is a modular architecture based on Li-Ion rechargeable cells (with a capacity of 2.3 Ah each) arranged in 8s3p layout, containing 3 strings in parallel, each consisting of 8 cells in series. Mechanical structure of battery includes heaters and thermostats (nominal and redundant) to keep the battery temperature within the operational temperature range, while controlling relay is mounted on CEU unit. Recharging is realised through a 7 pin micro connector in EDM Connector Bracket using a dedicated ground support equipment compatible with ISO 7 environment specifications. Current lifetime prediction for the battery is around two sol for nominal operation on Mars

2.3. Metmast assembly

Except for the pressure sensor head and microARES electrode all external atmospheric probes are located on the external MetMast which carried Dreams-H, MarsTem, MetWind and SIS sensors. All sensors were electrically connected to the CEU with a dedicated harness through the EDM connector plate following a dedicated functional scheme as reported in Fig. 4.

2.3.1. Mars TEM

Mars Tem temperature sensor is based on platinum resistance probes, wound on an insulating structure in order to increase the convective exchange with Mars atmosphere. Two sensor heads are present, one for fine and one for coarse measurement; the sensing element for both channels is a 99.99% platinum, 0.0508 mm diameter, 700 mm long wire studied to achieve a low response time on Mars surface (around 10–15 s). The coarse sensor, fixed in a more protected position of the supporting titanium structure, will allow dynamic correction of the measurements of the fine sensor by retrieving the titanium structure time constant, and will help to define better the solar radiation contribution on the fine sensor. The resistances have been calibrated in the expected operative range and representative values are 32 Ohm at 20 °C and 22 Ohm at –80 °C with excellent linearity. The realised reading circuit is based on a 3 wire configuration with pulsed 1 mA current generation; duty cycle for each sensor is around 2.5% in order to reduce self heating of the probe. The expected performance on Mars’ surface implies an accuracy below 0.1 K and resolution around 0.04 K. Further information on the sensor can be found in [13].

2.3.2. DREAMS-P and DREAMS-H

DREAMS-P is a capacitive sensor for measuring pressure on the Martian surface. The device consists of two pressure transducers,

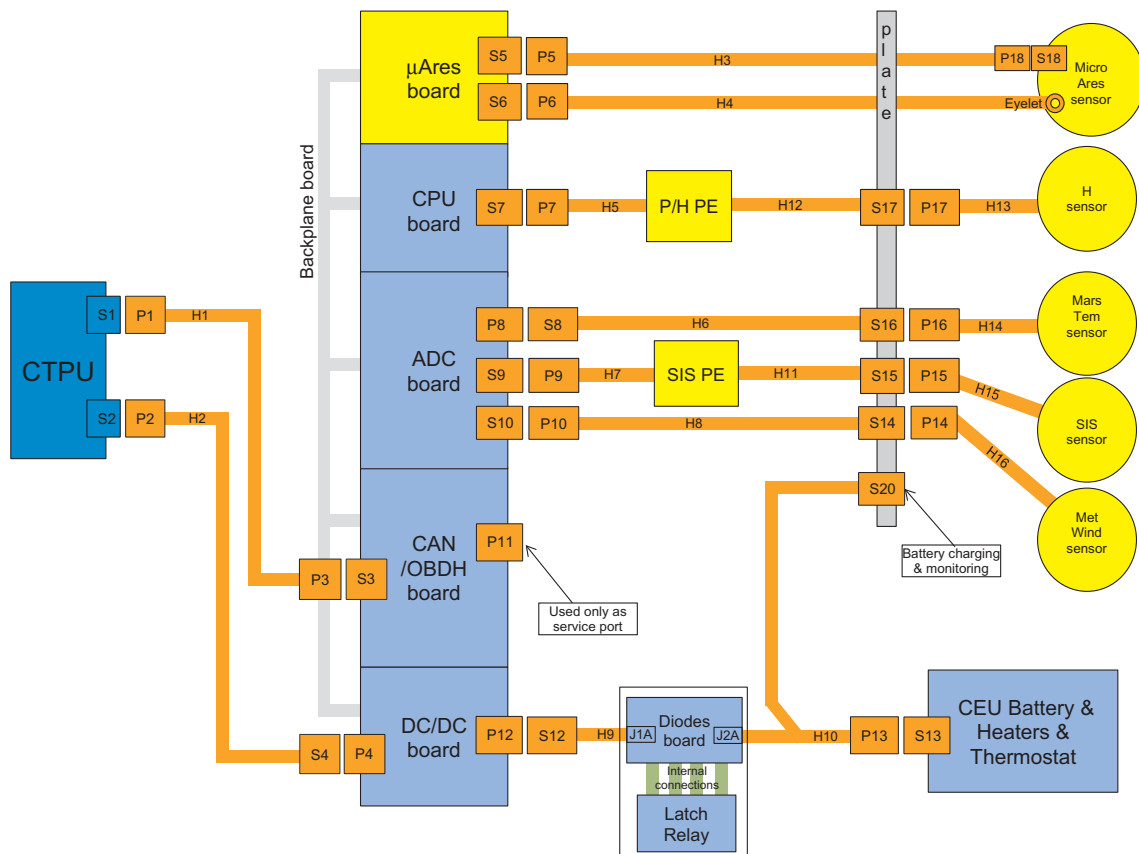

Fig. 4. DREAMS connection diagram.

including a total of four Vaisala Inc. Barocap® micromachined capacitive silicon sensors, built onto the same printed circuit board. The DREAMS-P sensor is controlled by two Vaisala application-specific integrated circuits.

DREAMS-H is a capacitive sensor for measuring humidity on the surface of Mars and it consists of one humidity transducer including three Vaisala Humicap sensor heads, an accurate Vaisala Thermocap temperature sensor head, and 4 constant reference channels, which are operated sequentially. It is also controlled by a Vaisala application-specific integrated circuit. The humidity transducer is an active polymer film which changes capacitance as a function of relative humidity. The sensor has to be regenerated or dried by heating resistors in order to reset the film to the reference condition. DREAMS-P and DREAMS-H share a common power line routed from the CEU through the proximity electronic with a tested power consumption of 60 mW on +5 V line and 80 mW/sensor on +12 V line.

Further information on the sensor performance can be found in [10,11].

2.3.3. MetWind

The Metwind sensor measurement chain consists of a sensor head and an electronics board realising a thermal anemometry approach similar to that used on Mars Pathfinder and different from the hot point strategy developed for the Rover Environment Monitoring Station (REMS) in MSL [9,14]. The sensor head consists of three thin-film platinum heat transfer gauges, equally spaced around the circumference of a vertical cylinder. Each film is resistively heated using a constant current raising its temperature above the one of the surrounding environment. The film's electrical resistance is then measured, allowing calculation of the temperature and thus the heat transfer coefficient at each hot film. The differences in heat transfer coefficients between the three films is used to calculate a 2-dimensional wind vector perpendicular to the axis of the wind sensor.

The Metwind sensor is a re-flight of the Beagle 2 Wind Sensor with the addition of a conformal coating on platinum films in order to protect them during mechanical swabbing for planetary protection activity. The wind sensor has been calibrated in the Mars wind tunnel facility at Oxford University and shows an average power consumption of 60 mW.

2.3.4. microARES

microARES measurement architecture is based on a single external sensing electrode, realising a simplified version of the standard double probe technique normally used to measure electric fields in space. The electrical field determination, with respect to the lander ground, aims to detect potentials up to 100 V amplitude ranging from DC to 3.2 kHz. Balloon borne experiments have shown that this simplified single

electrode technique provides reliable measurements of the local atmospheric potential at the probe position from which DC and AC vertical atmospheric electric fields are calculated from simple electrostatic modelling. As the input element of the analog electronics the floating pre-amplifier maintains the required very high input impedance over the full voltage range and feeds two data processing channels. The DC channel measures the high amplitude electric fields from DC to 3.2 kHz while the AC channel is used for the low amplitude AC signals between ~4 Hz and 3.2 kHz. Both channels are multiplexed and digitalized by a 16 bits ADC. Specific sequences of operation of short duration with a reduced sensitivity of the input preamplifier, are used to measure the possibly very large electric fields associated with dust devils or dust storms. A relaxation technique is used to determine the positive and negative atmospheric conductivities by measuring the relaxation time of the probe potential after it has been displaced from its equilibrium value. The digital electronics is organized around a DSP that controls the sequences of operation, the data acquisition and formatting and the data packet transmission to the CEU. Average power requested by μ -ARES is 0.28 W with peaks of 0.85 W.

Table 1 Main metrological parameters for DREAMS sensors.

2.3.5. SIS: Solar Irradiance Sensor

Solar Irradiance Sensor is based on a previous instrument, MetSIS, which was development to be used on Mars MetNet Mission. The objective of the SIS is the measurement of the intensity of the radiation at the surface of Mars in the range between 220 and 1320 nm. SIS sensor consists of an Optical Head located on top of the Metmast and a processing electronics box installed on the CEU assembly. The OH also includes some front-end conditioning electronics, whereas the PE contains a 16-bit analog-to-digital converter as well as the processing electronics (FPGA), memory and interfacing circuitry with CEU. Measurement chain is based on silicon photo detectors, a combination of interference and density filters and mechanical field of view shaping masks. It includes 7 detectors arranged on a truncated tetrahedron with face angle of 60° to avoid the dust deposition on the sensors active area. The sensor aims at the study of the intensity of the ultraviolet (UV) radiation in the Martian surface, seasonal variations of O₃, characterization of atmospheric opacity due to the Martian dust variations, correlation studies together with temperature, pressure and humidity sensors also present in the mission, and monitoring of water content variations during dawn and dusk. The instrument has an average power consumption of 400 mW.

Further information on the sensor can be found in [15].

Table 1
DREAMS Sensors performance.

DREAMS Sensors performance				
Name	Measured Parameter	Range	Resolution	Accuracy
MARS TEM	Temperature	70–320 K	0.02 K	0.1 K
DREAMS P	Pressure	0–1015 hPa calibration optimised for: 4–12 hPa range	0.5 Pa	5 Pa
DREAMS H	Relative Humidity	0–100%	0.5%	2% RH (0 °C), 5% RH (–40 °C), 8%RH (–70 °C)
METWIND	Wind speed and direction	0.3–30 m/s		1 m/s speed 10° direction
μ -ARES	Electric field	DC channel: –256 to +256 V/m (standard) > 10 kV/m (high) AC channel: 4–3200 Hz, 15 V/m (standard) 0.2 V/m (high)	DC channel: 8 mV/m (standard) 0.1 V/m (high) AC channel: 0.2 mV/m (standard) 3 μ V/m (high)	10–50%
SIS	Intensity of radiation	0–1050 W/m ² (@ M#1 λ = 220–1200 nm) 0–100 W/m ² (@ M#2 λ = 315–400 nm) 0–390 W/m ² (@ M#3 λ = 700–1100 nm)	10 ^{–3} W/m ² (@ M#1) 10 ^{–4} W/m ² (@ M#2) 3.7 * 10 ^{–4} W/m ² (@ M#3)	0.3–30% (@ M#1) 0.1–10% (@ M#2) 0.01–10% (@ M#3)



Fig. 7. DREAMS mission timeline for operation in day 1 showing sensor activation windows (in green) after expected landing and orbiter passage timelines (in red) in Mars local Time. (For interpretation of the references to colour in this figure legend, the reader is referred to the web version of this article.)

Data acquisition was driven by three Mission Timelines (MTL) stored in the non-volatile memory of the unit. Each MTL contained the operations foreseen during one sol and the data acquisitions were scheduled with respect the Mars Local True Solar Time; in this way the acquisitions may be correlated with the local events e.g. sun rise, sun set and specific part of the sol. Acquired data were stored in the non-volatile memory of the unit waiting to be uploaded to the EDM. To save energy both DREAMS and the EDM were designed to enter a low-power mode and wake-up simultaneously by synchronization of internal timers. At wake-up DREAMS would upload data to the EDM, then the EDM would transfer data to the orbiters, notifying to DREAMS the time of the next communication window.

The design and validation of the three surface MTLs was a crucial step of DREAMS mission, since MTLs were designed as a compromise among scientific goals, available energy and communication constraints linked to the timeline of orbiters passages over the landing site (see Fig. 7).

Due to the limitation in available energy, DREAMS sensors could not be kept activated continuously, but a series of regulated switch on sequences were stored for every sensor in the MTLs specifying sampling rate settings for optimization of data compression process.

To fulfil the scientific goals of the mission, measurement sequences requested to monitor the atmospheric parameters during the whole day with different extensions: activations shall be more frequent during the day-time and longer around the mid-day to investigate convective activities. Longer sampling windows were foreseen also at twilight to measure the humidity peak and study clouds properties.

In parallel other requirements related to power consumption and data transmission needed to be satisfied to guarantee mission success: power consumption needed to be minimized in order to guarantee at

least 2 sols of data acquisition, acquisition and storage of about 50 Mbit of data per sol shall be guaranteed with maximum energy consumption of 120 Wh and 5% energy margin at the last data upload to the EDM. DREAMS needed also to wake-up when expected by the EDM with no more than 500 ms of margin and guarantee that during the communication with the EDM μ -ARES is off to avoid disturbing the communications between the EDM and the orbiters, since a possible source of interference was detected as a result of EMC radiated testing.

The MTLs design was also optimised considering DREAMS power consumption in every operational sequence. Power consumption in all possible activation combinations was characterised during TV testing at different operative temperatures (see Table 2).

The expected operative temperature profile for all DREAMS package

Table 2
Expected Temperature ranges for DREAMS.

DREAMS Elements	Minimum Temperature [°C]	Maximum Temperature [°C]
Internal walls	-63.1	+12.9
Battery cells	+5.0	+13.0
Battery box	-2.9	+7.5
CEU boards	-19.0	+29.9
CEU walls	-21.0	+12.4
SIS PE	-21.2	+11.8
Dreams P-H PE	-21.3	+11.8
MetMast	-92.2	+17.8
μ Ares electrode	-89.4	+17.7
External sensors	-95.0	+11.2

All calculated temperature ranges present values within the expected limits of operation.

Table 3
Expected power consumption during surface operation depending on DREAMS state.

State	Power mode	Typical Power (W)	Maximum Power (W)
Idle	Idle	0.46	2.18
Data acquisition	Acquisition	7.66	11.69
μARES acquisition		6.77	10.56
Analog Sensors acquisition		5.35	8.26
TM Data Upload	TM Data Upload	4.47	7.12
	Battery Switch On	4.47	7.12
	Update CEU	4.47	7.12
	Dump CEU	4.47	7.12
	Health Check	4.47	7.12
Idle	Idle	0.02	0.02

elements was calculated with a detailed thermal model taking into account CO₂ heat exchange within the warm compartment and time dependent conductive and radiative boundary conditions as well as the above mentioned power consumption for operation. The following Table 3 reports the maximum and minimum temperature values (within the first two sols) expected for main DREAMS elements.

The expected power consumption of DREAMS depending on the state of operation and characterized during FM thermo-vacuum test campaign is listed in following Table 3.

The overall power consumption was evaluated considering the typical power consumption with the operative states expected during the MTLs execution and during the communication with the EDM by means of a software mission simulation tool.

The final MTLs were designed taking into account the list of orbiter passages provided by ESA. It was composed by 43 sensor activations of different duration (from 5 min to 1 h) distributed over two sols. Total acquisition time was around 11 h and 20 min over 51 h and 48 min of operation. The overall data volume expected was about 118 Mbit. The

start of the SURFACE phase was expected around 2016-10-19 at 14:48:17 and the battery depletion was expected around 2016-10-21 at 18:50:00. The power consumption and produced data volume profiles are reported in the following Fig. 8.

The final SURFACE MTLs were validated through a 2 sols real-time test on the DREAMS FS at CISAS premises, and all the design constraints were verified checking the test results.

5. DREAMS in-flight and on Mars performances

During the trip to Mars, DREAMS was activated several times for health check and sensors calibration and to perform update of mission timelines. A total of 8 DREAMS check-outs were executed during cruise and performances of all the units and sensors were as expected. Two MTLs updates were executed during cruise and upload performed nominally.

The EDM landing platform during the cruise phase of the mission experienced vacuum and dry conditions thus the readings from DREAMS-P and DREAMS-H sensors were used to verify and correct ground calibrations.

MetWIND was turned on several times in low-power mode (about 2 mW) to avoid overheating of its sensitive films. The high-power mode (40 mW) was tested only once for less than 10 s. The evolution of films temperature confirmed the sensor performances.

SIS detectors were in a dark environment enabling the characterization of the noise in its photodetectors. Finally, μ-ARES was checked only in terms of digital housekeeping and functional behaviour.

As may be seen in Fig. 9, which reports all DREAMS activity during the ExoMars 2016 mission, the instrument was also switched on during the final part of the Mars descent due to the wrong activation sequence performed by EDM central electronic unit. When surface mode was detected DREAMS nominally started communication with the EDM and sent its “ready to operate” final telemetry packet which was relayed to Earth by the orbiting ExoMars satellite. The data contained result of health check of all DREAMS components, (with all parameters nominal), demonstrating that the instrument would be able to operate perfectly after the long cruise and planetary descent.

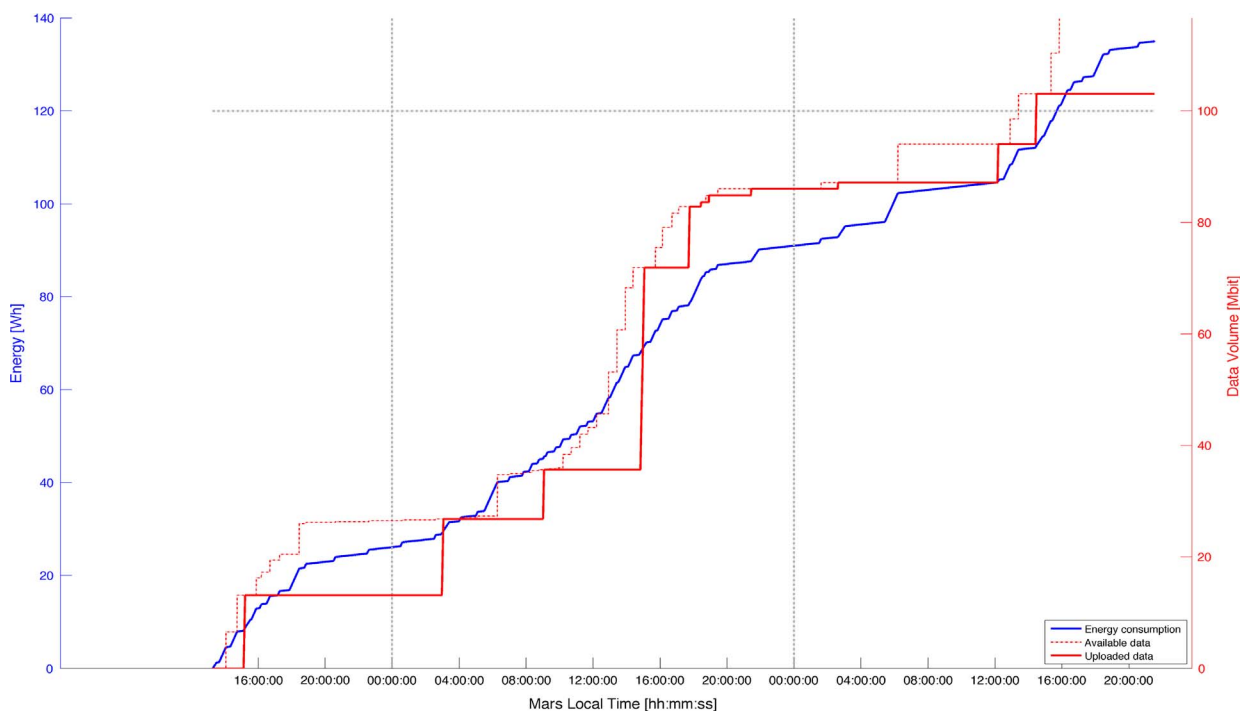

Fig. 8. DREAMS expected power consumption (in blue) and amount of produced data (in red) for whole operative lifetime on Mars. (For interpretation of the references to colour in this figure legend, the reader is referred to the web version of this article.)

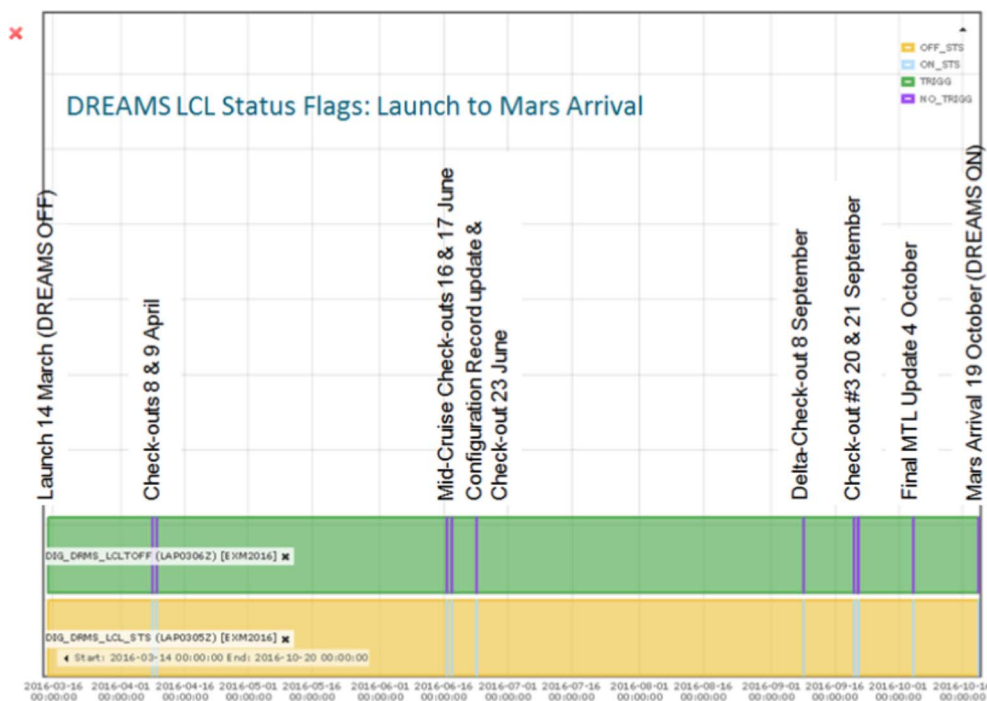

Fig. 9. In Flight activity of DREAMS during the whole Exomars2016 mission.

6. Future developments

DREAMS was designed as a modular unit, so the DREAMS spare models present at university of Padova premises can be reconverted quite easily for a different utilisation. DREAMS Flight Spare model is currently under testing for future utilisation in a cubesat mission with a reduced number of sensors and carrying a new board for camera acquisition.

DREAMS Qualification Model is being refurbished to be used as data logger and power distribution unit for a probe for future stratospheric balloon missions in collaboration with Italian Space Agency.

7. Conclusions

DREAMS was an autonomous meteorological suite specially designed for monitoring environmental parameters on the surface of Mars, which succeeded in fulfilling all scientific and technical requirements posed by the challenging Exomars2016 mission.

A total of three flight models were fully qualified before launch through an extensive test campaign comprising electrical and functional testing, EMC verification and mechanical and thermal vacuum cycling; furthermore following the requirements for planetary protection, contamination control activities and assay sampling were conducted before model delivery for final integration on spacecraft and in-flight tests conducted during the cruise to Mars and in the final atmospheric descent confirmed.

Unfortunately, the ExoMars 2016 EDM module failed the final part of the descent towards the surface and crashed so DREAMS was not able to provide direct measurements from the Mars surface. Anyway all cruise check outs and the activation commanded 20 s before impact showed that DREAMS hardware was in perfect before touchdown demonstrating the highest TRL of the unit for possible future missions.

Acknowledgment

DREAMS is developed by CISAS and INAF under coordination and funding by Italian Space Agency (ASI).

References

- [1] E. Chamberlain, H.L. Cole, R.G. Dutton, G.C. Greene, J.E. Tillman, Atmospheric measurements on Mars: the Viking meteorology experiment, *Bull. Am. Meteorol. Soc.* 57 (9) (1976) 1094–1104.
- [2] S.L. Hess, R.M. Henry, C.B. Leovy, J.A. Ryan, J.E. Tillman, Meteorological results from the surface of Mars: Viking 1 and 2, *J. Geophys. Res.* 82 (1977) 4559–4574.
- [3] X. Guo, W.G. Lawson, M.I. Richardson, A.D. Toigo, Fitting the Viking lander surface pressure cycle with a Mars general circulation model, *J. Geophys. Res.* 114 (2009) E07006, <http://dx.doi.org/10.1029/2008JE003302>.
- [4] M.T. Mellon, B.M. Jakosky, H.H. Kieffer, P.R. Christensen, High-resolution thermal-inertia mapping from the Mars global surveyor thermal emission spectrometer, *Icarus* 148 (2000) 437–455.
- [5] M.D. Smith, M.J. Wolff, M.T. Lemmon, N. Spanovich, D. Banfield, C.J. Budney, R.T. Clancy, A. Ghosh, G.A. Landis, P. Smith, B. Whitney, P.R. Christensen, S.W. Squyres, First atmospheric science results from the Mars Exploration Rovers Mini-TES, *Science* 306 (2004) 1750–1753.
- [6] M. Fulchignoni, F. Ferri, F. Angrilli, A.J. Ball, A. Bar-Nun, M.A. Barucci, C. Bettanini, G. Bianchini, W. Borucki, G. Colombatti, M. Coradini, A. Coustenis, S. Debei, P. Falkner, G. Fanti, E. Flamini, V. Gaborit, R. Grard, M. Hamelin, A.M. Harri, B. Hathi, I. Jernej, M.R. Leese, A. Lehto, P.F. Lion Stoppato, J.J. Lopez-Moreno, T. Mäkinen, J.A.M. McDonnell, C.P. McKay, G. Molina-Cuberos, F.M. Neubauer, V. Pironello, R. Rodrigo, B. Saggin, K. Schwingenschuh, A. Seiff, F. Simoes, H. Svedhem, T. Tokano, M.C. Townner, R. Trautner, P. Withers, J.C. Zarnecki, In situ measurements of the physical characteristics of Titan's environment, *Nature* 438 (2005) 785–791.
- [7] C. Bettanini, M. Zaccariotto, F. Angrilli, Analysis of Huygens HASI accelerometers data at Titan Impact with dynamic simulation on a Huygens finite element model, *Planetary and Space Science* 56 (2008) 715–727.
- [8] J. Gómez Elvira, C. Armiens, L. Castañer, M. Domínguez, M. Genzer, F. Gómez, R. Haberle, A.M. Harri, V. Jiménez, H. Kahanpää, L. Kowalski, A. Lepinette, J. Martín, J. Martínez Frias, I. McEwan, L. Mora, J. Moreno, S. Navarro, M.A. de Pablo, V. Peinado, A. Peña, J. Polkko, M. Ramos, N.O. Renno, J. Ricart, M. Richardson, J. Rodríguez Manfredi, J. Romeral, E. Sebastián, J. Serrano, M. de la Torre Juárez, J. Torres, F. Torrero, R. Urquí, L. Vázquez, T. Velasco, J. Verdasca, M.P. Zorzano, J. Martín Torres, REMS: The environmental sensor suite for the Mars Science Laboratory rover, *Space Sci. Rev.* 170 (2012) 583–640, <http://dx.doi.org/10.1007/s11214-012-9921-1>.
- [9] M. Domínguez, V. Jiménez, J. Ricart, L. Kowalski, J. Torres, S. Navarro, J. Romeral, L. Castañera, A hot film anemometer for the Martian atmosphere, *Planet. Space Sci.* 56 (2008) 1169–1179, <http://dx.doi.org/10.1016/j.pss.2008.02.013>.
- [10] A.-M. Harri, M. Genzer, O. Kempainen, H. Kahanpää, J. Gomez-Elvira, J.A. Rodríguez Manfredi, R. Haberle, J. Polkko, W. Schmidt, H. Savijärvi, J. Kauhanen, E. Atskan, M. Richardson, T. Siili, M. Paton, M. de La Torre Juarez, C. Newman, S. Rafkin, M.T. Lemmon, M. Mischna, S. Merikallio, H. Haukka, J. Martín-Torres, M.-P. Zorzano, V. Peinado, R. Urquí, A. Lepinette, A. Scodary, T. Mäkinen, L. Vazquez, N. Rennó, the REMS/MSL Science Team, Pressure observations by the Curiosity rover: initial results, *J. Geophys. Res. Planets* 119 (2014) 82–92, <http://dx.doi.org/10.1002/2013JE004423>.

- [11] A.M. Harri, M. Genzer, O. Kemppinen, J. Gomez-Elvira, R. Haberle, J. Polkko, H. Savijärvi, N. Rennó, J.A. Rodriguez-Manfredi, W. Schmidt, M. Richardson, T. Siili, M. Paton, M. de la Torre-Juarez, T. Mäkinen, C. Newman, S. Rafkin, M. Mischna, S. Merikallio, H. Haukka, J. Martin-Torres, M. Komu, M.-P. Zorzano, V. Peinado, L. Vazquez, R. Urqui, Mars Science Laboratory relative humidity observations: initial results, *J. Geophys. Res. Planets* 119 (9) (2014) 2132–2147, <http://dx.doi.org/10.1002/2013JE004514>.
- [12] C.R. Mahaffy, M. Webster, P.G. Cabane, P. Conrad, S.K. Coll, R. Atreya, M. Arvey, M. Barciniak, L. Benna Bleacher, The sample analysis at Mars investigation and instrument suite, *Space Sci. Rev.* 170 (2012) 401–478.
- [13] I. Arruegoa, V. Apéstigüea, J. Jiménez-Martíña, J. Martínez-Otera, F.J. Álvarez-Ríos, M. González-Guerrero, J. Rivasa, J. Azcuea, I. Martíña, D. Toledo, L. Gómez, M. Jiménez-Michavilaa, M. Yelaa, “DREAMS-SIS: the solar irradiance sensor on-board the ExoMars2016 lander” 2016, *Adv. Space Res.* 60 (2017) 103–120, <http://dx.doi.org/10.1016/j.asr.2017.04.002>.
- [14] Claire E. Newman, Javier Gómez-Elvira, Mercedes Marin, Sara Navarro, Josefina Torres, Mark I. Richardson, J. Michael Battalio, Scott D. Guzewich, Robert Sullivan, Manuel de la Torre, Ashwin R. Vasavada, Nathan T. Bridges, Winds measured by the Rover Environmental Monitoring Station (REMS) during the Mars Science Laboratory (MSL) rover's Bagnold Dunes Campaign and comparison with numerical modeling using Mars WRF, *ICARUS* (2017), <http://dx.doi.org/10.1016/j.icarus.2016.12.016>.
- [15] Giacomo Colombatti, Carlo Bettanini, Alessio Aboudana, Stefano Debeia, Francesca Esposito, Cesare Molfese, Anselmo Cecere, John Merrison, Jens JacobIversen, Mars TEM sensor simulations in Martian dust environment, *Measurement* (2017).
- [16] Francesca Ferri, Özgür Karatekin, Stephen R. Lewis, François Forget, Alessio Aboudan, Giacomo Colombatti, Carlo Bettanini, Stefano Debei, Bart Van Hove, Veronique Dehant, Ari Mtti Harri, Mark Leese, Teemu Mäkinen, Ehouarn Millour, Ingo Muller-Wodarg, Gian Gabriele Ori, Andrea Pacifici, Sebastien Paris, Manish Patel, Mark Schoenenberger, Jeffrey Herath, Tero Sili, Aymeric Spiga, Tetsuya Tokano, Martin Towner, Paul Withers, Sami Asmar, Dirk Plettemeier, Exo Mars atmospheric mars entry and landing investigations and analysis (AMELIA), *Space Science Review Special Issue for Exo mars 2016*, *Space Sci. Rev.* (2017) (in press).
- [17] R.G. Harrison, E. Barth, F. Esposito, J. Merrison, F. Montmessin, K.L. Aplin, C. Borlina, J.J. Berthelier, G. Déprez, W.M. Farrell, I.M.P. Houghton, N.O. Renno, K.A. Nicoll, S.N. Tripathi, M. Zimmerman, Applications of electrified dust and dust devil electrodynamic to martian atmospheric electricity, *Space Sci. Rev.* 203 (1–4) (2016) 299–345.