



<b>Publication Year</b>	2015
<b>Acceptance in OA</b>	2020-04-17T10:41:32Z
<b>Title</b>	Modal noise in 850nm VCSEL-based radio over fiber systems for manifold applications
<b>Authors</b>	Nanni, J., Algani, C., Tartarini, G., RUSTICELLI, SIMONE, PERINI, FEDERICO, Viana, C., Polleux, J.-L.
<b>Publisher's version (DOI)</b>	10.1049/cp.2015.0112
<b>Handle</b>	<a href="http://hdl.handle.net/20.500.12386/24088">http://hdl.handle.net/20.500.12386/24088</a>

# MODAL NOISE IN 850nm VCSEL-BASED RADIO OVER FIBER SYSTEMS FOR MANIFOLD APPLICATIONS

*Jacopo Nanni<sup>1</sup>, Giovanni Tartarini<sup>1</sup>, Simone Rusticelli<sup>2</sup>, Federico Perini<sup>2</sup>,  
Carlos Viana<sup>3</sup>, Jean-Luc Polleux<sup>3</sup>, Catherine Algani<sup>4</sup>*

<sup>1</sup> DEI "Guglielmo Marconi", University of Bologna, Viale Risorgimento 2, 40136 Bologna, Italy

<sup>2</sup> IRA, National Institute for Astrophysics, Via Fiorentina 3513, 40059 Medicina, Italia

<sup>3</sup> Université Paris-Est – ESYCOM (EA2552) – ESIEE Paris, UPEM, Le Cnam, 93162 Noisy-le-Grand, France

<sup>4</sup> Le Cnam, ESYCOM (EA2552), 75003 Paris, France

**Keywords:** Modal Noise, VCSEL, RoF.

## Abstract

The combination of the 850nm VCSEL as optical source and of the Standard Single Mode Fiber as optical channel realizes an attractive solution for the distribution of the wireless signal through the Radio over Fiber technique. Potential causes of impairment which are however present in this solution are analyzed, and some conditions to be respected in view of the application of these systems in various scenarios are then identified.

## Introduction

High service quality and energy-efficiency, as well as low electromagnetic field exposure, can be obtained, in the distribution of the radio frequency (RF) signals, when the optical fiber is utilized as transmission channel. In this terms Radio-over-Fiber (RoF) systems have been confirmed as an optimal solution for signal distribution in various scenarios.

An interesting possibility is given in this context by the employment of vertical cavity lasers (VCSELs) operating at 850 nm, because of their low manufacturing cost and current consumption if compared to Distributed Feed Back (DFB) ones. Moreover, the adoption of Standard Single Mode Fibers (SSMFs) presents important advantages with respect to the cases where Multi Mode Fibers (MMFs) are used, namely lower cost per meter, future proofness, lower sensitivity to curvatures and greater flexibility in splitting operations, either WDM or not. The combination of 850nm VCSELs and SSMF can however potentially generate some impairments. Indeed, SSMFs feature a multimode behavior at 850 nm which causes problems both in terms of limited bandwidth and presence of modal noise.

These RoF links have been studied by researchers, who propose different methods for the mitigation of the above mentioned impairments. For example, to force mostly the fundamental mode of the SSMF single-transversal mode VCSELs have been employed in [1], [2] and [3], which however present limitations in the amount of optical power emitted. Moreover, different kinds of mode filters have been proposed in [4] and [5], reducing the simplicity and the cost effectiveness of the whole system. Finally, all these papers regard the transmission of digital signals through the optical link, computing the Bit Error Rate (BER) as the quality

parameter. As opposed to this treatment, in the case of RoF links it is necessary to analyse the effects of the studied impairments on the RF gain of the optical system in order to evaluate their impact on its performance. Once these effects are identified, it will be possible to find the limits to which the performance of RoF links can be pushed, maintaining at the same time their cost effectiveness.

In this paper, the influence of intermodal dispersion and modal noise on the RF gain of RoF links is evaluated in worst case scenarios, introducing strong discontinuities and letting the fiber undergo forced temperature variations. The study will be performed having in mind two different fields of application: the distribution of wireless signals inside buildings for Home area Network (HAN) [6], and the realization of multiple downlinks in large Radio-Astronomical antennas [7], as for example parabolas for Very Long Baseline Interferometry (VLBI). In both cases the signal can indeed be transmitted/received at an Intermediate Frequency (IF) of few GHz through RoF links with relatively short length, and keeping the above mentioned impairments under control in this operating conditions can allow the design of practical solutions for both scenarios.

## Theoretical analysis

### 1. Description of the causes of impairments

As mentioned in the Introduction, when RoF systems utilize a multimodal optical channel (either using MMFs or using SSMFs in the first optical window), two main problems arise which can lead to detrimental effects on their performance, namely intermodal dispersion and modal noise.

The first one is the well known phenomenon by which the different group velocities of the propagating modes determine a reduction of the passband of the optical channel.

Modal noise, on the other hand, is related to the fact that the propagation constants of the different modes exhibit different variations in correspondence to changes of external quantities (e. g. temperature), leading to time-varying phase differences among the propagating modes. If mode selective losses are present, caused for example by misalignments in optical connectors or by a limited detecting area of the photodiode utilized, these time-varying phase differences result, in the case of RoF systems, in undesired fluctuating behaviours of received power and distortion terms around their average values, impeding an accurate design of the system itself [8].

It must be noted that, while modal noise is potentially present in all short and medium range connections, intermodal dispersion does not typically constitute a major problem when graded index MMFs are utilized, which can typically exhibit bandwidths of some GHz over hundreds of meters of distance [9]. On the contrary, utilizing SSMFs in multimodal regime intermodal dispersion must be accurately considered. Indeed SSMFs, having not been designed for multimodal operation, are of step-index kind, and their Band-Distance product for  $\lambda=850\text{nm}$  is typically of the order of few hundreds of MHz Km. The combined presence of the two undesired phenomena is then a peculiarity of the system studied in this work.

## 2. Simplified mathematical model

In the case that is here studied, the value of the normalized propagation constant, computed starting from the standard parameters of G.652, is  $v \sim 3.2$  and the modes propagating in the SSMF are just the first ( $LP_{01}$ ) and the second ( $LP_{11}$ ).

To have a physical grasp of the phenomena taking place in the system, it will be considered the case when modal noise is caused by the finite detecting area of the photodiode. A similar description could be made assuming as a cause the misalignment between optical connectors.

It will be assumed that the multiple transversal mode emission of VCSELs determines an excitation of both fiber modes with the same amplitude  $A$ . Moreover, since the different lines of the emission spectrum exhibit mutual delays two orders of magnitude smaller than those exhibited by the two fiber modes, the VCSEL emission spectrum will be approximated with only one line with optical frequency  $f_0$ , possibly affected by frequency chirp. Due to the short fiber length considered, for both  $LP_{01}$  and  $LP_{11}$  modes a complete coupling within the constituting groups of degenerate modes will be assumed, while the coupling among groups is assumed to be negligible [10].

The electrical field at the output section of a span of optical fiber of length  $L$  can then be represented as:

$$\begin{aligned} \overline{E}_{out}(t, L) = & \sum_{i=1}^2 A_i \overline{e}_i(x, y) e^{j(2\pi f_0 t - \beta_i(t)L)} * \\ & * \sqrt{1 + m_l \cos[2\pi f_{RF}(t - \tau_i)]} * \\ & * e^{-jm_p \sin[2\pi f_{RF}(t - \tau_i)]} \end{aligned} \quad (1)$$

where  $\overline{e}_i(x, y)$  is the normalized field of the  $i$ -th mode propagating in the fiber,  $A_i = A$  is its amplitude (assumed real without loss of generality), while  $\beta_i(t)$  is its phase constant. The latter quantity is assumed as time-varying, due to changes in environmental quantities, like temperature. The term  $A_1^2 + A_2^2 = 2A^2$  is proportional to  $\eta_0(I_{bias} - I_{th})$ , where  $\eta_0$  is the current-power conversion efficiency of the laser at DC, while  $I_{bias}$  and  $I_{th}$  are respectively the laser bias and threshold currents. The quantity  $f_0$  is the optical carrier's frequency, and  $m_p = \frac{K_f I_{IN,RF0}}{f_{RF}}$  is the phase modulation index of the optical wave determined by the frequency chirp of the laser. Within  $m_p$ ,  $K_f$  is the laser adiabatic chirp factor,  $I_{IN,RF0}$  is the amplitude of the modulating RF current  $I_{IN,RF} = I_{IN,RF0} \cos(2\pi f_{RF} t)$ , and  $f_{RF}$  is its frequency. The values of

$f_{RF}$  range from some hundreds MHz to a few GHz. With  $m_l$  the optical modulation index is indicated, defined as  $m_l = \frac{\eta_{RF} I_{IN,RF0}}{\eta_0(I_{bias} - I_{th})}$ , where  $\eta_{RF}$  is the current-power conversion efficiency of the laser at frequency  $f_{RF}$ . The quantity  $\tau_i$  is the group delay of the  $i$ -th mode caused by the propagation in the fiber span.

The received current is proportional to the optical power received on the photodiode surface  $S_{PD}$  (a Responsivity  $\mathcal{R}=1$  is assumed), namely:

$$I_{OUT}(t, L) = \int_{S_{PD}} |\overline{E}_{out}(t, L)|^2 dS \quad (2)$$

It will be assumed that, due to the finite extension of  $S_{PD}$ , the integral  $\int_{S_{PD}} \overline{e}_1 \overline{e}_2^* dS = b_{12}$  exhibits a nonzero value.

Assuming that in Eq.(1) the square root and the term  $e^{-jm_p \sin[2\pi f_{RF}(t - \tau_i)]}$  can be taken in their expansion up to the first order, after simple derivations, the component  $I_{OUT,RF}$  of the detected current at frequency  $f_{RF}$  can be determined. The expression of  $I_{OUT,RF}$  results in turn to be the sum of three addends where the terms which oscillate at frequency  $f_{RF}$  are respectively multiplied by:

$$I_{OUT,RF0} = 2A^2 m_l \cos(\pi f_{RF} \Delta\tau L) \quad (3)$$

$$I_{OUT,RF1}(t) = 2A^2 b_{12} m_l \cos(\pi f_{RF} \Delta\tau L) \cos[\Delta\beta(t)L] \quad (4)$$

$$I_{OUT,RF2}(t) = 2A^2 b_{12} 2m_p \sin(\pi f_{RF} \Delta\tau L) \sin[\Delta\beta(t)L] \quad (5)$$

where  $\Delta\tau = \tau_2 - \tau_1$  and  $\Delta\beta(t) = \beta_2(t) - \beta_1(t)$ . The terms reported in Eq. (3) yields the average amplitude of the received RF current, while Eq.(4) and (5) refer to the undesired slowly fluctuating contributions ( $\Delta\beta(t)L$  may exhibit a variation of  $2\pi$  in periods of the order of tens of seconds) which are due to modal noise and add or subtract in time to  $I_{OUT,RF0}$ .

In absence of the fluctuating terms, (4) and (5), the module of the RF power gain  $|G_{RF}|$  of the RoF link, would be given by  $|G_{RF}| = I_{OUT,RF0}^2 / I_{IN,RF0}^2$ . In presence of the fluctuating terms this quantity is still meaningful, since it represents the time average of  $|G_{RF}|$  and allows to put into evidence the effect of intermodal dispersion. It results indeed:

$$\langle |G_{RF}| \rangle \propto |\cos(\pi f_{RF} \Delta\tau L)|^2 \quad (6)$$

where  $\langle \dots \rangle$  means time averaging.

The consequent bandwidth limitation can be appreciated in Fig.1, where an almost complete mutual cancellation of the RF signal portions carried by the two modes is present at the frequencies for which the product  $\pi f_{RF} \Delta\tau L$  is an odd multiple of  $\pi/2$ . The very good agreement with the simple model which assumes the presence of only two modes with the same weight can be appreciated. It can be additionally noted that, at the same frequencies which nullify  $\langle |G_{RF}| \rangle$ , while the fluctuating contribution associated with Eq.(4) is going to zero, the one coming from Eq.(5) gives its highest contribution. It is therefore expected that for those frequencies the values the fluctuations of the RF gain module will be very high in relative terms.

This will be appreciated in the following section, referring

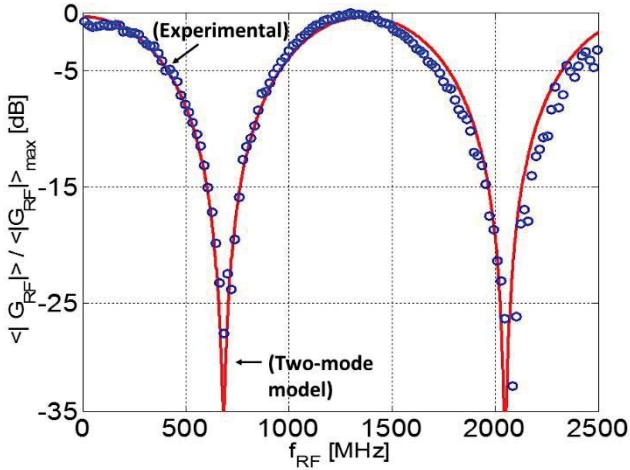

Fig. 1. Effect of intermodal dispersion inside 300m of the SSMF fiber utilized in this work.

to the quantity  $\sigma_G$  defined as:

$$\sigma_G = \text{std} \left\{ \left. \frac{|G_{RF}|}{\langle |G_{RF}| \rangle} \right|_{\text{dB}} \right\} \quad (7)$$

where  $\text{std}\{\dots\}$  means standard deviation, which is typically utilized to quantify the impairments caused by modal noise in Radio over Fiber links.

## Experimental results and discussion

To characterize VCSEL-based RoF links based on SSMFs, the experimental setup shown in Figure 2 has been utilized. A Vectorial Network Analyzer (VNA) was used to generate and receive different frequencies through port 1 and port 2 respectively. The modulated source was an Optowell VCSEL 10 Gbps biased at 4 mA, which received -10 dBm of RF power from the VNA. The optical receiver was based on photodiode (PD) if PIN type. To force modal noise, a temperature stress was produced by the insertion of the G.652 strand inside a climatic chamber, controlled and monitored by a Resistor Temperature Detector (RTD) sensor connected to a digital data acquisition block. Everything was connected to a PC through GPIB cables and controlled and monitored with a Labview® GUI.

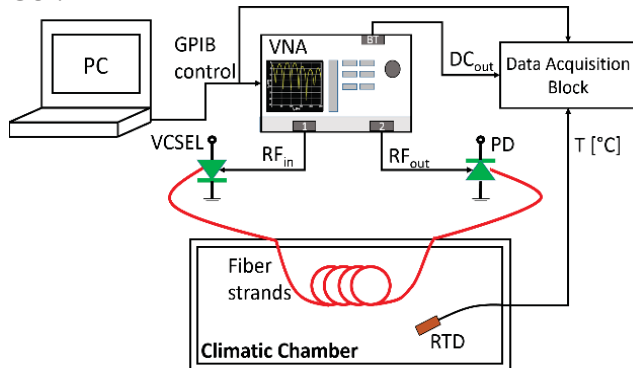

Figure 2: Experimental setup of modal noise effect measurements.

As a typical example, Fig. 3 reports the measured behaviour of  $\sigma_G$  for a SSMF strand of length  $L=300\text{m}$ . Taking  $\sigma_G = 2\text{dB}$  as a reference level, it can be noticed that relatively high values

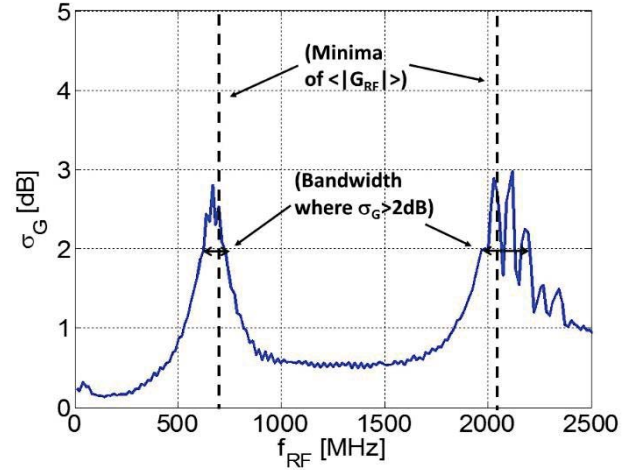

Fig. 3. Experimental measurement of RF gain standard deviation for 300 m of G.652 fiber.

$\sigma_G$  were measured within an important range of frequencies centered around the points of minimum of  $\langle |G_{RF}| \rangle$ .

A first obvious guideline emerging from these results is then to operate sufficiently far from the first minimum of  $\langle |G_{RF}| \rangle$  to keep under control the impact of modal noise. In order to adequately quantify this statement, a further experimental analysis was performed, focused on the evaluation of modal noise effects in an extreme situation. To this purpose, between the SSMF and the PD a short span of Thorlabs 780HP 5- $\mu\text{m}$  core diameter fiber (SMF5), having a numerical aperture  $\text{NA} = 0.13$ , was put. This configuration emulates the effects of a small area photodetector, and/or of a very bad alignment between optical connectors, and can then be utilized for a worst-case analysis.

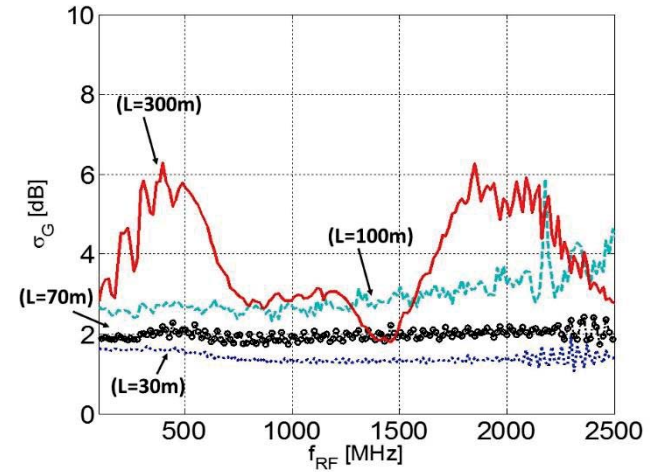

Fig. 4. Typical behaviours of  $\sigma_G$ , for different SSMF lengths.

Figure 4 shows the measured behaviour of  $\sigma_G$  at different lengths in this last configuration. With respect to the case without SMF5, for  $L=300\text{m}$  it is now  $\sigma_G > 2\text{dB}$  in all the considered bandwidth. On the contrary, a value approximately equal or lower than  $2\text{dB}$  is observed for shorter fiber lengths (up to 70 m), which however are typically utilized in the scenarios envisaged in this work.

In order to further assess the applicability of VCSEL-based RoF links, a comparison was performed utilizing a MMF span

instead of the SSMF one. The considered length was 70 m, in both cases. Fig. 5 shows the behaviour of  $\langle |G_{RF}| \rangle$  for the two links. The absence of steep null points can be appreciated in both cases, since the frequency range considered is well within the passband of the RoF links.

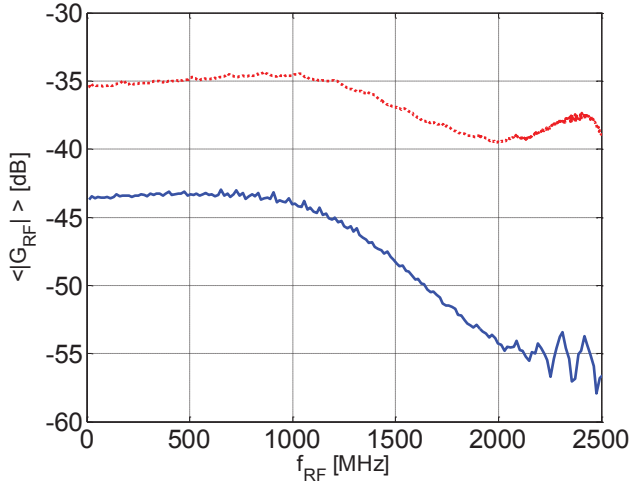

Fig. 5. Comparison of  $\langle |G_{RF}| \rangle$  between the MMF-based (red dotted line) and SMF-based (blue solid line) RoF links for 70 m of link length.

Moreover, the comparison in terms of  $\sigma_G$  represented in Figure 6 shows that, practically, there are not differences regarding the modal noise effect, either in presence or in absence of the SMF5 patchcord, leading to the conclusion that the two systems feature similar performance.

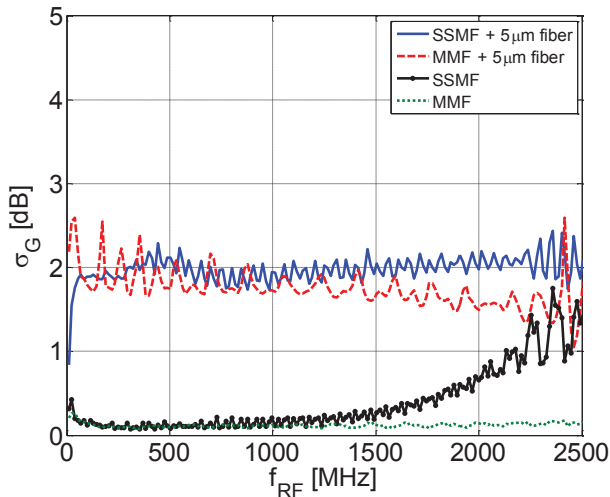

Fig. 6. Comparison in terms of  $\sigma_G$  of the MMF-based and SSMF-based 70m RoF links considered, when the fiber is directly connected to the PD and when the SMF5 is placed between them.

An important difference is anyway present in terms of  $\langle |G_{RF}| \rangle$  (see again Fig.5), which is about 8 dB higher when the MMF is used. This difference is due to the spatial filtering of the VCSEL transverse modes performed by the SSMF. The adoption of single transversal mode VCSEL mentioned in the Introduction could reduce this problem, but at the price of a lower power emission, requiring a trade off decision. In any

case, the improvement of the VCSEL-SSMF coupling is a primary result to pursue in these systems.

## Conclusions

An analysis of Radio over Fiber systems adopting 850nm VCSELs and SSMF has been performed. The combined action of modal noise and intermodal dispersion, which is connected to the choice of these components, has been shown to be controllable in short range links, also in situations where its detrimental impact is potentially high, allowing to create attractive solutions in terms of both cost and performance in different applicative scenarios.

## References

- [1] M.Stach, F.I.Pomarico, D.Wiedenmann, R.Michalzik, «High-Performance Low-Cost Optical link at 850 nm With Optimized Standard Singlemode Fiber and High-Speed Singlemode VCSEL,» *ECOC Proc.*, 2004.
- [2] D.Vez, S.G. Hunziker, R. Kohler, P.Royo, M.Moser, W.Bachtold, «850 nm vertical-cavity laser pigtailed to standard singlemode fibre for radio over fibre transmission,» *Electronic letters*, 2004.
- [3] P.Schnitzer, R. Jager, C.Jung, R.Michalzik, D. Wiedenmann, F.Mederer and K.J.Ebeling, «Biased and Bias-Free Multi-Gb/s Data Links Using GaAs VCSEL's and 1300-nm Single-Mode Fiber,» *IEEE Photonics Technology Letters*, vol. 10, 1998.
- [4] Z. Tian, C.Chen, D.V.Plant, «850-nm VCSEL Transmission Over Standard Single-Mode Fiber Using Fiber Mode Filter,» *IEEE Photonics Technology Letters*, 2012.
- [5] T.Shimizu, K.Nakajima, K.Shiraki, N.Hanzawa, T.Kurashima, «Multi-Band Mode Filter for Shorter Wavelength Region Transmission over Conventional SMF,» *OFC/NFOEC*, 2008.
- [6] J. Guillory, Y. Ait Yahia, A. Pizzinat, B. Charbonnier, C. Algani, M. D. Rosales, J. L. Polleux, «Comparison between two 60GHz multipoint RoF architectures for the Home Area Network,» *17th NOC*, pp. 1-5, 2012.
- [7] R. Beresford, «ASKAP Photonic requirements,» *IEEE Conf. on Microwave Photonics*, pp. 62-65, 2008.
- [8] R. E. Epworth, «Modal noise causes and cures,» *Laser Focus*, vol. 17, pp. 109-115, 1981.
- [9] G. Alcaro, D. Visani, L. Tarlazzi, P. Faccin, G. Tartarini, «Distortion Mechanisms Originating From Modal Noise in Radio Over Multimode Fiber Links,» *IEEE Trans. MTT*, vol. 60, n. 1, pp. 185-194, 2012.
- [10] P. Pepeljugoski, S. E. Golowich, a. J. Ritger, p. Kolesar, A. Risteski, «Modeling and Simulation of Next-Generation Multimode Fiber Links,» *IEEE Journal of Lightwave Technology*, vol. 21, n. 5, pp. 1242-1255, 2003.