



Publication Year	2017
Acceptance in OA	2020-09-14T13:51:34Z
Title	PROSPECTing the Moon: Numerical Simulations of Temperature and Sublimation Rate on a Regolith Cylindric Sample
Authors	FORMISANO, Michelangelo, DE SANCTIS, MARIA CRISTINA, DE ANGELIS, Simone, Carpenter, J. D.
Handle	http://hdl.handle.net/20.500.12386/27357

PROSPECTing the Moon: Numerical simulations of temperature and sublimation rate on a regolith cylindrical sample

M. Formisano¹, M.C. De Sanctis¹, S. De Angelis¹, J. D. Carpenter²

¹ INAF-IAPS (Rome, Italy) (michelangelo.formisano@iaps.inaf.it)

² ESA ESTEC, Keplerlaan 1, 2401 AZ, Noordwijk, The Netherlands

Abstract

The goal of the ESA PROSPECT mission [1] is to extract and characterize a regolith sample from the lunar south polar region, investigating its physical and chemical properties. The main target is to characterize the abundance and distribution of water ice and other volatiles so challenge is to preserve volatiles in samples during the drilling transfer and analysis.

Numerical simulations have been used to predict the expected ice sublimation rates and inform the system's development.

Numerical Model

Our analysis concerns the study of a cylinder, representing a lunar regolith sample in the South Pole region. We developed different scenarios where the sample has different boundary temperatures as well as initial water ice content (see Table 1).

The numerical model is based on a 3D finite element method (FEM) [2].

Ice diffusion is treated by using a mass conservation equation, in which the diffusion coefficient is calculated according to the kinetic theory of gases [3,4,5]

We assume that water vapor acts as a perfect gas and the local thermodynamic equilibrium is valid.

Thermal conductivity, specific heat and density of the ice-regolith mixture are weighted according the assumed volumetric concentrations.

We assume water loss only through one open face of a sample container.

Geometry & Initial Conditions

The adopted sample is a cylinder of 3mm of diameter and 6 mm height (see Figure 1), which approximates the expected size of the PROSPECT ovens. The cylinder is covered by a triangular mesh, whose maximum element size is 0.048 mm. All sides are held at a constant temperature during a single simulation. Temperature modeled ranges from 148 K to 223 K. The sample's initial temperature is fixed at 123 K. The initial water ice content ranges from 0.1 to 10 vol.%. The remaining component is modeled with the typical physical parameters of the lunar regolith [6]

The evolution of a sample's temperature and water content is then simulated over a two hour period.

The analyzed scenarios are listed in Table 1.

Results and Future Works:

Our results show that a significant loss of ice content is obtained only in the case of high boundary temperature of the sample container (223 K) (we recall that the initial temperature is always fixed to 123 K). In the case of a low thermal gradient between the sides and the interior of a sample, the ice loss is negligible.

Figure 2 shows results for the C1 case, in which the sides are at 148 K and the initial water ice content is of 10 vol.%, corresponding to about 2×10^{-6} kg of ice, which survives throughout the simulation.

Model	Water Ice Content Vol. %	Boundary Temperature [K]
A1	0.1	148
A2	0.1	173
A3	0.1	223
B1	1	148
B2	1	173
B3	1	223
C1	10	148
C2	10	173
C3	10	223

Table 1. Scenarios analyzed in our simulations.

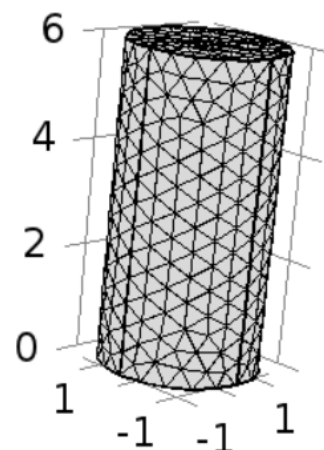

Figure 1. Cylindrical mesh.

We observe that, 100 minutes after the beginning of the simulations, the ice loss is negligible.

In the C3 scenario (see Figure 3), where the boundary temperature is at 223 K and the initial temperature is 10 vol.%, the complete loss of the initial ice occurs after 30 minutes.

Future simulations will test different cylindrical sizes as well as different physical/chemical properties, with a view to informing the evolving PROSPECT development.

Acknowledgements

This work was performed in the context of the PROSPECT User Group and in support of ESA’s lunar exploration activity.

References

[1] Carpenter, J.D. et al. 2015, Lunar Expl. Analysis Group, LPI, 2015
 [2] Formisano, M. et al. 2017, in preparation.
 [3] De Sanctis, M.C. et al. 2010, Icarus, 207, 341
 [4] Lasue J. et al. 2008, Planet. Space Sci., 56, 1977
 [5] Espinasse, S., 1991, Icarus, 92, 350.
 [6] The Lunar Source Book, edited by Grant H. Heiken, David T. Vaniman, Bevan M. French ©1991, Cambridge University Press

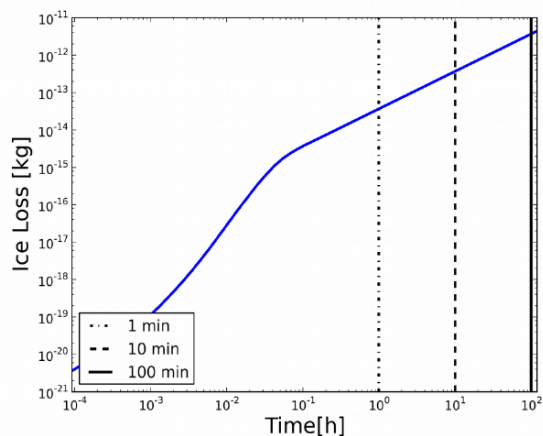

Figure 2. Ice loss vs integration time plot, in C1 case (10 vol.% and boundary temperature at 148 K.)

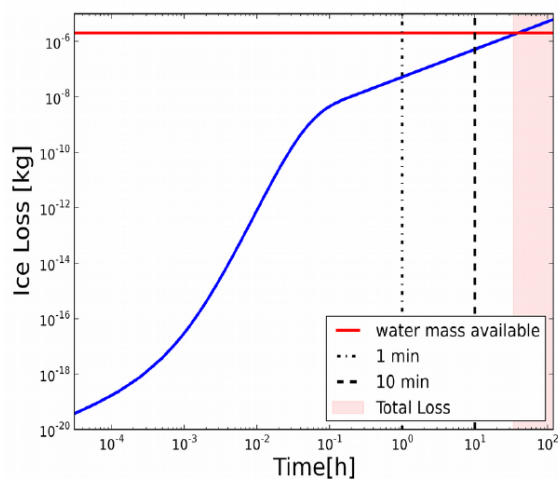

Figure 3. Ice loss vs integration time plot, in C3 case (10 vol.% and boundary temperature at 223 K.)