



| | |
|----------------------------------|---|
| Publication Year | 2015 |
| Acceptance in OA | 2020-03-30T16:03:25Z |
| Title | Interface Management for SKA Telescope Manager |
| Authors | Swart P.S., le Roux G.M., MARASSI, Alessandro, SMAREGLIA, Riccardo, Vircic S., Chaudhuri S.R. |
| Publisher's version (DOI) | 10.18429/JACoW-ICALEPCS2015-MOD3O06 |
| Handle | http://hdl.handle.net/20.500.12386/23713 |

INTERFACE MANAGEMENT FOR THE SKA TELESCOPE MANAGER

P.S. Swart*, G.M. le Roux, SKA South Africa NRF, South Africa
 A. Marassi, R. Smareglia, INAF-OAT, Italy
 S. Viracic, NRC-Herzberg, Canada
 S.R. Chaudhuri, TRDDC, India

Abstract

The Square Kilometre Array (SKA) project is currently in the Pre-construction Phase. During this phase, the telescope subsystems are being designed. The Telescope Manager (TM) is a supervisory control and monitoring subsystem in each of the two radio telescopes of the SKA (SKA1-Low and SKA1-Mid). The TM interfaces with a number of diverse telescope subsystems. Interaction between TM and these subsystems is a major source of requirements for the TM. Careful management of TM external interfaces is therefore important. This discussion is a case study of TM interface management. Firstly, how system architectural design aspects like separation of concerns in the control hierarchy reduce telescope complexity with regards to interfaces is discussed. Secondly, the standardisation approach for monitoring and control interfaces to facilitate early elicitation of interface requirements for the TM, and to manage the diversity of interfacing subsystems is discussed. Thirdly, the relations between interface definition and requirements analysis activities, using SysML representations as an example is discussed.

BACKGROUND

The SKA Phase 1 (SKA-1) Observatory will consist of the general headquarters and two radio telescopes: SKA1-Mid in South Africa and SKA1-Low in Australia. Each telescope consists of a number of sub-systems, which are in the SKA project referred to as Elements, of which a TM is one.

There are therefore two TM items, namely SKA1-Mid TM and SKA1-Low TM. For brevity, in this paper the focus is on SKA1-Mid TM (therefore omitting specifics of SKA1-Low TM) because the two telescopes are similar from the TM perspective in its function and interfaces. For less formal reading, "TM" is used when referring to common aspects of these two items, whereas "SKA1-Mid TM" refers to the TM of the SKA1-Mid telescope.

TM OVERVIEW

The TM is a distributed, computer-based supervisory Monitor and Control (M&C) system. TM is responsible for managing [1]:

- astronomical observations,
- telescope hardware and software sub-systems in order to perform those astronomical observations,
- data to support users in achieving operational, maintenance and engineering goals.

For observation management the TM: assists creation, assessment and approval of science proposals; generates schedulable observation units from science proposals; schedules observations; and coordinates execution of the observations to achieve the data products required by the end user.

Telescope management entails configuration and high level control of the telescope Elements and collection of monitoring data which allows the user to monitor the status of Elements, infrastructural support systems and environmental conditions that impact telescope operations.

The Telescope status and configuration data are managed to form a system model that describes the status of the telescope in real-time and historically. To achieve this, the TM collects and stores telescope configuration, telescope dynamic status and environmental data. Stored data are presented to users as current and historic telescope state to assist users during system integration, commissioning, operations and maintenance.

SKA1-MID TM EXTERNAL INTERFACES

This paragraph gives an overview of the external interfaces of the TM, using SKA1-Mid TM as an example (refer [1] par. 1.3). Figure 1 shows SKA1-Mid TM and the systems that it interfaces with.

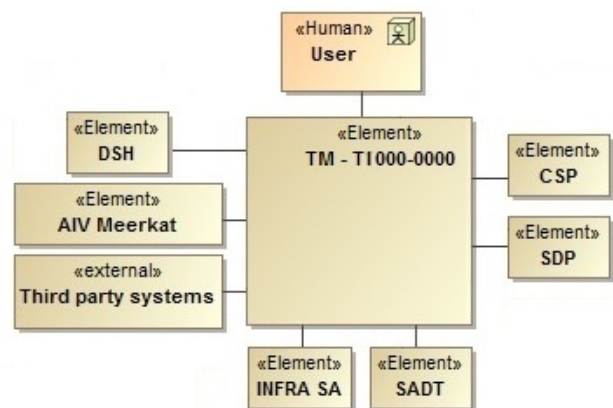

Figure 1: TM relations with SKA environment.

Interfaces with Telescope Elements

The TM has two basic types of interfaces with Elements: data exchange, and physical. The data exchange interface type is categorised into: M&C, general, networking and synchronisation and

*paul@ska.ac.za

timing. Categories of the physical interface type are: mechanical, power and cooling.

The TM has M&C data exchange interfaces with Elements that are to be monitored and controlled: Central Signal Processor (CSP), Science Data Processor (SDP), Dish (133 Dishes), 64 dish Karoo Array Telescope (MeerKAT) Local Monitor and Control (LMC) and Signal and Data Transport (SADT). For M&C of the MeerKAT telescope (to be integrated into SKA1-Mid telescope), LMC sub-systems are developed, which will interface with TM.

TM, via general data exchange interfaces, provides to CSP & SDP parameters required for delay tracking, beamforming, calibration, radio frequency interference mitigation, and auxiliary data that the SDP augments science data with.

Via synchronisation & timing and networking data exchange interfaces, the SADT provides services to TM.

Interfaces with Observatory Systems

TM provides the telescope's user interfaces (UIs) to scientists, observation planners, engineers, commissioners, maintainers, and operators. The TM has an application programming interface for users to programmatically create scheduling blocks. TM collects failure related data from Elements, and sends these to the Integrated Logistic Support System via a data exchange interface. TM has a data exchange interface with South African Infrastructure (INFRA SA) to obtain key indicators of INFRA status that affect telescope operations, and local weather data.

The TM uses infrastructural services (such as cooling and electrical power) provided by INFRA SA via physical (mechanical, thermal and electrical) interfaces with INFRA SA.

Interfaces with External Systems

The TM provides information from external systems (outside of the boundaries of the SKA observatory) to other SKA Elements and users, as required. These external systems are either custom experiment hardware or providers of services like: astronomical catalogues, flight information, earth orientation parameters, ionospheric prediction, satellite information, Virtual Observatory Events and weather information.

TM Interface Challenges

The TM interfaces with a diverse set of systems and implements a number of external interfaces. Interaction with such a large number of systems can be a major source of requirements for TM if interfaces are diverse and there is strong coupling between TM and interfacing systems. Careful interface management of TM external interfaces is required to address this diversity.

The SKA project is a collaboration of Element Consortia; each Element Consortium consists of a number of geographically distributed institutions, which poses the challenge of communication and coordination.

TM design work started before a comprehensive, central telescope architecture was available, causing some initial uncertainty of TM scope and boundaries.

The following paragraphs contain some strategies employed and experiences gained during TM interface management.

SKA OBSERVATORY ARCHITECTURE AND TM INTERFACES

The SKA Organisation introduced separation of concerns by allocating local M&C functions to each SKA Element (referred to as Element LMC). Building on this, and to reduce complexity, we defined a control hierarchy, with less frequent, judgement-based human intervention at the top, the TM with telescope and sub-array level coordination in the middle, and frequent real-time autonomous control by Element LMC at the bottom [3].

On the monitoring side, the Element LMC performs metering and low level, real-time monitoring, whereas TM collects sensor data and performs monitoring in the telescope or sub-array context, using sensor data aggregations provided by Element LMCs.

Layering of M&C responsibilities causes separation of concerns [5] and enabled M&C interface standardisation.

M&C INTERFACE STANDARDISATION

Development work at Element level started before a central, comprehensive telescope architecture was established. The absence of a functional model, that allocates specific functions to Elements, meant uncertain scope and boundaries w.r.t. telescope M&C. The TM Consortium launched an M&C standardisation effort to set initial scope and boundaries for TM and its interfacing parties, and to generate an early, basic set of interface requirements for TM, to be refined later. This M&C standardisation reduced interface diversity from an M&C perspective and also produced guidelines to improve technical communication between Element consortia.

Approach

Activities in each phase of the Telescope development life cycle were identified and analysed. This analysis was done from the point of view of understanding whether TM needed to play a role in any of these activities.

The exercise helped us to identify the key TM functions, TM role in SKA operations and dependencies on other SKA systems. The list of TM responsibilities includes facilitating integration of Elements, telescope management, maintenance and usage.

Each TM function that involves interaction with other Elements of SKA was analysed to understand the information dependency between them. This helped to arrive at the appropriate information content and protocol that the interface between TM and the Elements needed to support. Few examples of such information are the self-description of the Elements provided to TM to facilitate their integration in SKA, information about their operational interface such as commands, events, alarms

and so on that would be used by TM to control them. It also described behavioural aspects like control models.

We saw the need to standardize information content and created the LMC interface guidelines document. We used available standards from the public domain such as X.731 towards this standardization activity.

The LMC interface guidelines document was circulated to all the Element consortia for their feedback. The Element representatives provided their feedback on the content of this guideline which was then subsequently accepted as the standard to be used by all Element LMC's for interfacing with TM.

Selection of TANGO as M&C Framework

Standardization effort for interfaces between TM and Element LMCs includes the following aspects: general principles, required functionality, format and content of the messages and communication infrastructure. As soon as the general requirements for these interfaces were identified, the SKA team started investigations related to the communication protocols and frameworks to be used for implementation. TM Consortium provided leadership in this area and invited all other SKA Consortia to identify, investigate and suggest candidate technologies. TM Consortium developed a comprehensive list of requirements and criteria for selection of the communication framework for communication between TM and other SKA Elements. The list of candidate technologies and criteria for selection were reviewed by all SKA Consortia that implement M&C interface with TM. In March 2015, representatives of all SKA Consortia met in Trieste, Italy to discuss the proposed technologies and criteria for selection. The programme included presentations by the experts for the proposed technologies. At the end of the meeting TANGO Control System (CS) was identified as a technology of choice for implementation of the M&C interfaces between TM and other SKA Elements.

The decision to use TANGO CS for interface between the Elements does not mean that TANGO CS will be used for M&C function internal to the Elements; but the report from the meeting recommends to all SKA Consortia to use TANGO CS internally where possible and suitable. TM itself will use TANGO CS for internal M&C.

INTERFACE DEFINITION AND TM REQUIREMENT ANALYSIS

From allocation of Telescope requirements to TM in [2], a functional structure for TM was derived. TM functions were specified by TM requirements in [1]. TM interactions with other Elements were covered in TM requirements by referring to interfaces from requirement text, for example, "The SKA1_MID TM shall send time stamped desired pointing coordinates to the Dish via its I.S1M.TM_DSH.001 interface". Up to now, SysML (refer [6]) representations of TM behaviour were limited to use case diagrams (Fig. 2) and swimlane activity diagrams (Fig. 5).

The SysML specification [6] provides a precise model based representation for interfaces and interface instance integration [5]. We are currently working towards modelling information exchange between the TM and other Elements as SysML object flows. Once functions that are allocated to TM and other Elements have been modelled as SysML activities, and the activities have been allocated to TM and Elements via SysML blocks, the object flow between the TM and Elements can be shown. Thus the systems behaviour (functions) and system structure (interfaces) can be brought together by tracing each object flow to the allocated interface port and connector uniquely identified by its interface number (see Fig. 3 & Fig. 4).

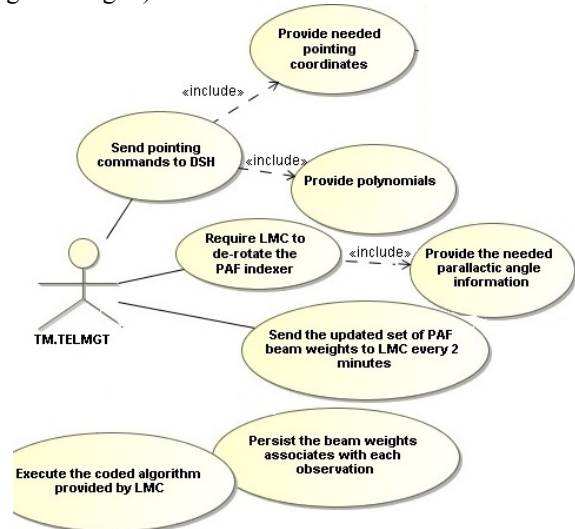

Figure 2: Dish pointing control use case diagram.

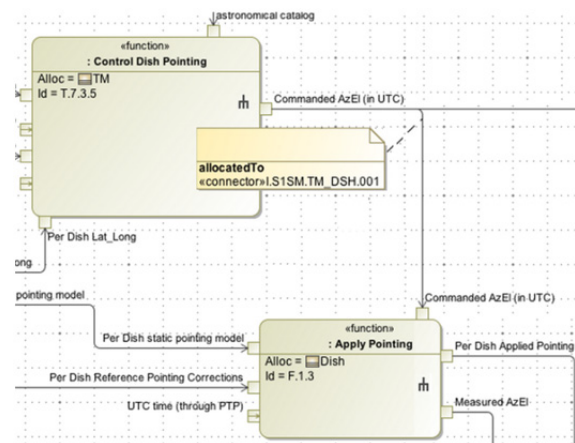

Figure 3: Behavioural view – interface and object flow.

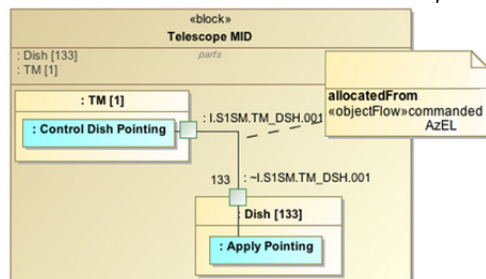

Figure 4: Structural view – interface & object flow.

Copyright © 2015 CC-BY-3.0 and by the respective authors

USER INTERFACE DEVELOPMENT

A requirement is a documented physical and functional need that a particular design, product or process must be able to perform. Interfaces provide the specifications of relevant properties of a system or component that can be connected to other systems or components together with their actual interaction. When users interact with a computer system, they do so via a UI.

Starting from the requirements as defined, collected and organized in [1] & [2], and the SKA Concept of Operations and Use Cases documentation provided by the SKA Office in [4], a users and tasks analysis phase followed in order to develop a solid conceptual model of stakeholders and of the interfaces involved in the operation of the SKA Observatory from a TM point of view. Documentation of SKA pathfinders and precursors on operational concepts, actors and systems has been considered too.

A project glossary was used to unambiguously define and describe actors, roles and tasks in the application domain. SysML use case diagrams were used to represent system scenarios and interactions workflows, then detailed out with via textual descriptions and swimlane activity diagrams to fully describe dynamic behaviour (see Fig. 5 an example of TM interactions with Dish and the operator in a specific scenario.

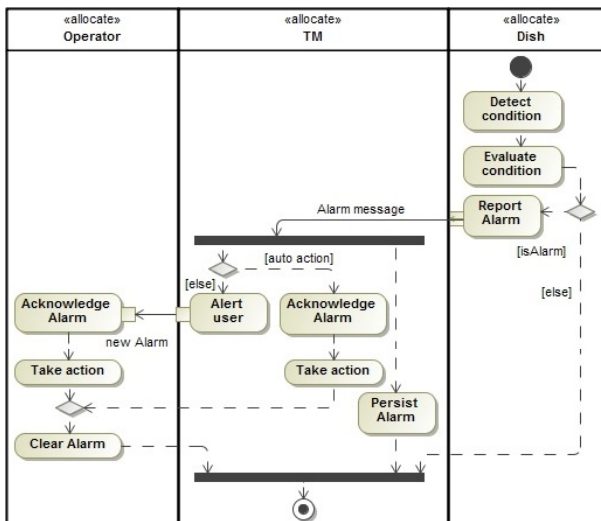

Figure 5: Alarm reporting SysML swimlane diagram.

A user-centred approach will be adopted in TM UI development. It will consist of several iterations, involving users’ active contribution (interviews, brainstorming sessions, feedback) to fully understand user needs in performing the tasks that they have to perform while interacting with TM and the actual usage environment (organisational, social, and physical). User-centred design is hoped to optimize usability as Part 11 of the ISO 9241 standard [7] defines it as “the extent to which a product can be used by specified users to achieve specified goals with effectiveness, efficiency and satisfaction in a specified context of use.”

Prototypes will be used to elicit detail requirements and highlight possible critical dependencies between different components, drive out technical gaps, get stakeholders and end users feedback, test common framework tools and libraries, interaction flows and common look and feel, evaluate usability and accessibility.

Validation interviews will be performed with a subset of real users or user proxies.

SUMMARY

The external interfaces of the TM Element of the SKA are diverse and many. Resulting complexity is handled by M&C separation of concerns and interface standardisation while SysML is used in models that integrate interface definition with requirements analysis, and supports UI analysis and design. M&C standardisation and UI design and development are two of the focus areas of the TM Consortium in interface management.

ACKNOWLEDGMENT

The authors wish to acknowledge all past and present members of the Telescope Manager Consortium.

REFERENCES

- [1] P.S. Swart, G. le Roux, Y. Wadadekar, L. van den Heever, A. Bridger, J.C. Guzman, “SKA1 TM Requirement Specification”, T0000-0000-RS-001, Revision F, July 2015.
- [2] W. Turner, “SKA Phase 1 System (Level 1) Requirements Specification”, SKA-TEL-SKO-0000008, Revision 4, September 2014.
- [3] P.S. Swart, “SKA TM Design Report”, T0000-0000-DR-001, Revision D, June 2015.
- [4] R. McCool, “Technical Use Cases”, SKA-TEL-SKO-0000016, Revision 1, August 2014; https://my.alfresco.com/share/s/nF-dp1kbQwC_GG388KuRjw
- [5] E. Fosse, C.L. Delp, “Systems Engineering Interfaces: A Model Based Approach”, in Proceedings of 2013 IEEE Aerospace Conference, IPAC’14, Big Sky, MT, USA (2013); <http://dx.doi.org/10.1109/AERO.2013.6497322>
- [6] Object Management Group, “OMG Systems Modeling Language (OMG SysML TM), version 1.3,” OMG, Tech. Rep. OMG document number formal/2012-06-01, June 2012; <http://www.omg.org/spec/SysML/1.3/>
- [7] ISO 9241-11:1998 Ergonomic requirements for office work with visual display terminals (VDTs) - Part 11: Guidance on usability.