



Publication Year	2018
Acceptance in OA	2020-10-29T15:44:23Z
Title	Progress in the realization of the beam expander testing x-ray facility (BEaTriX) for testing ATHENA's SPO modules
Authors	SALMASO, Bianca, SPIGA, Daniele, BASSO, Stefano, GHIGO, Mauro, GIRO, Enrico, PARESCHI, Giovanni, TAGLIAFERRI, Gianpiero, VECCHI, Gabriele, Pelliciani, C., Burwitz, V., Sanchez del Rio, M., Ferrari, C., Zappettini, A., USLENGHI, MICHELA, FIORINI, MAURO, Parodi, G., Ferreira, I., Bavdaz, M.
Publisher's version (DOI)	10.1117/12.2312565
Handle	http://hdl.handle.net/20.500.12386/28092
Serie	PROCEEDINGS OF SPIE
Volume	10699

PROCEEDINGS OF SPIE

[SPIDigitalLibrary.org/conference-proceedings-of-spie](https://spiedigitallibrary.org/conference-proceedings-of-spie)

Progress in the realization of the beam expander testing x-ray facility (BEaTriX) for testing ATHENA's SPO modules

B. Salmaso, D. Spiga, S. Basso, M. Ghigo, E. Giro, et al.

B. Salmaso, D. Spiga, S. Basso, M. Ghigo, E. Giro, G. Pareschi, G. Tagliaferri, G. Vecchi, C. Pellicciari, V. Burwitz, M. Sanchez del Rio, C. Ferrari, A. Zappettini, M. Uslenghi, M. Fiorini, G. Parodi, I. Ferreira, M. Bavdaz, "Progress in the realization of the beam expander testing x-ray facility (BEaTriX) for testing ATHENA's SPO modules," Proc. SPIE 10699, Space Telescopes and Instrumentation 2018: Ultraviolet to Gamma Ray, 106993I (6 July 2018); doi: 10.1117/12.2312565

SPIE.

Event: SPIE Astronomical Telescopes + Instrumentation, 2018, Austin, Texas, United States

Progress in the realization of the Beam Expander Testing X-ray facility (BEaTriX) for testing ATHENA's SPO modules

B. Salmaso^{1a}, D. Spiga^{a,b}, S. Basso^a, M. Ghigo^a, E. Giro^a, G. Pareschi^a, G. Tagliaferri^a, G. Vecchi^a, C. Pelliciani^c, V. Burwitz^c, M. Sanchez del Rio^d, C. Ferrari^e, A. Zappettini^e, M. Uslenghi^f, M. Fiorini^f, G. Parodi^g, I. Ferreira^h, M. Bavdaz^h

^aINAF/Brera Astronomical Observatory, Via E. Bianchi 46, 23807 Merate, Lecco (Italy)

^bSLAC, 2575 Sand Hill Road, Menlo Park, CA 94025 (USA)

^cMax-Planck-Institut für extraterrestrische Physik, Garching (Germany)

^dEuropean Synchrotron Radiation Facility, B.P. 220, 38043 Grenoble (France)

^eCNR-IMEM, Parco Area delle Scienze 37/A, 43124 Parma (Italy)

^fINAF-IASF Milano, Via E. Bassini 15, 20133 Milano (Italy)

^gBCV Progetti, Via S. Orsola 1, 20123 Milano (Italy)

^hESTEC, European Space Agency, Keplerlaan 1, 2201 AZ Noordwijk (Netherlands)

ABSTRACT

The construction of the BEaTriX (Beam Expander Testing X-ray) facility is ongoing at INAF/Osservatorio astronomico di Brera. The facility will generate a broad ($170 \times 60 \text{ mm}^2$), uniform and low-divergent (1.5 arcsec HEW) X-ray beam within a small lab ($\sim 9 \times 18 \text{ m}^2$), using an X-ray microfocus source, a paraboloidal mirror, a monochromatization system based on a combination of symmetrically cut and asymmetrically-cut crystals in Bragg diffraction configuration. Once completed, BEaTriX can be used to test the Silicon Pore Optics modules of the ATHENA X-ray observatory, as well as other optics, like the ones of the Arcus mission. The facility is designed to operate at 1.49 keV and 4.51 keV, by using two fixed beam lines, equipped with the necessary optical elements. The first beam line to be completed will be at 4.51 keV and will prove the BEaTriX concept. Silicon crystals are used at this energy and four symmetric diffractions, with appropriate tilt of some crystals, will provide the spectral filtering at the required level to return the desired divergence. Owing to the quite short range necessary to obtain a parallel beam with this setup, a low vacuum level (10^{-3} mbar) can be used without a significant beam extinction. In addition to a modular vacuum approach, the low vacuum will allow us to reduce the time required to evacuate the tank, thus enabling to demonstrate a test rate that will match the ATHENA SPO production of 3 MM/day. In this paper, we report the design of the facility and the construction progress.

Keywords: BEaTriX, X-ray test facility, micro-focus source, beam expander, asymmetric diffraction

1. INTRODUCTION

ATHENA is an X-ray mission proposed by a consortium led by MPE and officially approved in 2014 for the L2 slot in the ESA Cosmic Vision program [1]. With respect to previous X-ray missions, ATHENA will have unprecedented effective area (2 m^2 at 1 keV, with possible descoping at 1.45 m^2), wide field of view (40 arcmin x 40 arcmin) and excellent angular resolution (5 arcsec HEW required and a 3 arcsec HEW goal). Since 2004, ESA/ESTEC adopted the technology of Silicon Pore Optics (SPO) [2] as a manufacturing baseline for ATHENA and its predecessors (XEUS, and subsequently IXO). This approach, developed in collaboration with *Cosine Research B.V.*, is based on the utilization of commercially-available silicon wafers. The SPO production process is being constantly improved to reach the required quality and production level [3,4]. Currently, 35 processed silicon plates are stacked with dedicated robotic machines to form an X-ray Optical Unit (XOU); 4 XOUs (two of them operating the first reflection in parallel, followed by the two XOUs in charge of the second reflection) are integrated into a Mirror Module (MM); the MMs have to be aligned and

¹ bianca.salmaso@brera.inaf.it; phone +39-039-5971028; fax +39-039-5971001; www.brera.inaf.it

finally integrated in the full Mirror Assembly (MA). Each step of this process has to be followed by dedicated tests and calibration procedures. The integration of the XOUs into MM is now performed at the Bessy synchrotron [5]. Media Lario [6] and Thales CH [7] are studying different co-alignment techniques of the MMs. The completed MA has to be eventually calibrated and different solutions are considered, including an extended PANTER [8] or the XRCF facility at MSFC (USA). In between the XOUs integration and the MMs integration, all the MMs will have to be tested for acceptance: at this step, the BEaTriX facility will play a key role, to characterize the MMs with X-ray full illumination, and at the requested MM production rate.

X-ray tests of the MMs are currently performed at the PTB laboratory of the BESSY synchrotron facility in pencil beam configuration [5,9], but they require a PSF reconstruction from each pore's, or groups of pores, exposure. Full illumination X-ray tests could be performed using a broad and low-divergent X-ray beam, e.g. at PANTER (MPE, Neuried, Germany), possibly compensating the beam divergence by the application of a diffractive X-ray lens [10]. However, the large volume to be evacuated makes it impossible to perform the functional tests at the MMs production rate (3 MM/day).

To overcome these limitations, INAF/OAB is developing in Merate (Italy) the BEaTriX (Beam Expander Testing X-ray) facility. This apparatus will generate a broad (170 mm × 60 mm), uniform, and low divergent (1.5 arcsec) X-ray beam within a small lab (9×18 m² including the foundations – see Section 5.1). This will be possible thanks to an X-ray microfocus source (30 μm focal spot) in the focus of a paraboloidal mirror, a monochromation system with symmetrically cut crystals and an asymmetrically-cut crystal for beam expansion. A beam expander of this type was already implemented successfully at the Daresbury synchrotron [11]. However, the beam expansion was limited to a single direction, and the obtained divergence was much larger. BEaTriX will operate at the monochromatic X-ray energies of 4.51 keV and 1.49 keV, and it will fully illuminate the aperture of SPO mirror modules, imaging the beam focused by an SPO MM at 12 m distance, where the camera will be appropriately placed. The high flux generated by the micro-focused source, and the highly monochromatic beam produced by the optical elements will enable the Effective Area and PSF characterization with high accuracy. All the system will be under a vacuum level of 10⁻³ mbar, and the modular vacuum approach will enable a fast interchange of the MMs. Once completed, BEaTriX can be used to test the SPO MMs of the ATHENA X-ray observatory, as well as other optics, like the Arcus mission.

The design of BEaTriX, started in 2012 [12], has been continuously evolving [13,14,15] thanks to an AHEAD (Activities for the High-Energy Astrophysics Domain) grant awarded from H2020 [16], and to other dedicated INAF funds. Since 2018, the development of BEaTriX is also funded by ESA with a dedicated contract. The goal of this activity – kicked-off in mid-April 2018 and to be developed in an 18-month timeframe - is to prove the concept of BEaTriX for the 4.51 keV energy and thereafter to extend it to the 1.49 keV.

With respect to previous designs [15] (named BEaTriX 1.0 throughout this paper), a few important changes have been made:

- the vacuum level
- the monochromation stage
- the mechanical design
- the laboratory project.

This paper reports the to-date current design of the facility (heretofore dubbed as BEaTriX 2.0), outlining the motivations for the changes, and reporting the advancements in its construction.

Section 2 reports the modification on the vacuum level. Section 3 describes the optical layout, with special attention paid to the monochromation stage modification. Section 4 describes the mechanical design, and Section 5 summarizes the design of the laboratory foundations.

2. THE VACUUM LEVEL

All the system needs to be evacuated to minimize X-ray absorption in air. The total range of X-rays from source to detector at the end of the 12 m long tube is approximately 19 m. Due to the reduced dimensions of the facility, only a moderate vacuum level is required: in a previous paper [15] we had already shown that a 10⁻² mbar residual pressure would suffice to preserve at least 97% of the beam intensity for both the 4.51 keV and the 1.49 keV beams. Nevertheless, a pressure fluctuation in the 10⁻³ - 10⁻² mbar range would produce a noticeable (from 99.7% to 97.3%) change in the X-ray transmissivity at 1.49 keV, which would therefore affect the accuracy in the effective area measurement. In contrast,

the absorption of 4.51 keV photons along the ~ 19 m vacuum tube (Fig. 1) is almost unaffected by pressure variations in the same range. Adopting a base pressure of 10^{-2} mbar, a stability of 1% around would be necessary to keep the systematic error in the effective area within tolerable levels. Therefore, in order to ensure the effective area measurement accuracy at 1.49 keV, the baseline vacuum level for BEaTriX is now 10^{-3} mbar. A combination of dry primary vacuum pumps and turbo pumps will be used to reach the 10^{-3} mbar pressure, with the following requirements:

- quick pumping down (approx. 30 min) for the MM tank, that needs to be evacuated 3 times per day, i.e., every time the MM under test is changed;
- cleanliness: oil-free pumps are being evaluated to avoid the contamination of the optical elements and the MM under test;
- pump vibrations should be damped by proper systems to avoid the propagation to the vacuum system.

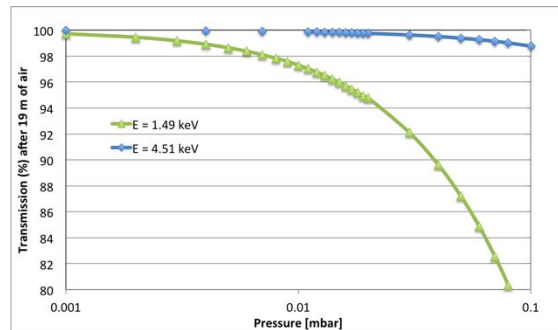

Figure 1: Transmission of X-ray photons of 4.51 keV and 1.49 keV, along the 19 m vacuum tube of BEaTriX, as a function of residual vacuum pressure

3. OPTICAL DESIGN AND THE NEW MONOCHROMATION STAGE

The X-ray flux, generated by an X-ray microfocus source, is moderated by a chain of optical elements in order to obtain a broad, uniform and low-divergent X-ray beam: a paraboloidal mirror, a crystal monochromation system, and an asymmetrically-cut diffracting crystal (Fig. 2). In this section, we review the requirements of these components. In Section 3.3.1, we describe the current configuration for the monochromation system, which currently foresees two Channel-Cut-Crystals in lambda-dispersive configuration, aiming at reducing the energy passband impinging on the asymmetric crystal. This was relevant to obtain a final horizontal divergence below 1.5 arcsec HEW (Fig. 4).

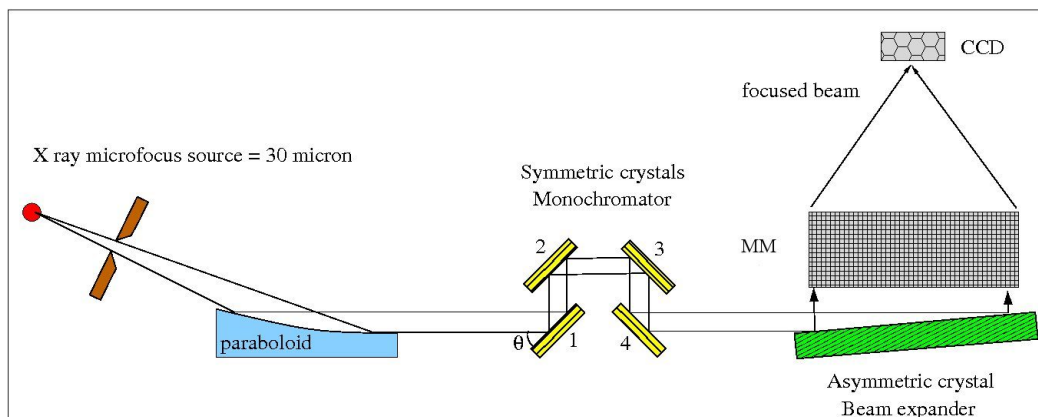

Figure 2: Optical layout of BEaTriX 2.0.

3.1 The X-ray source

A micro-focus X-ray source generates an intense X-ray beam including the fluorescence lines of the elements composing the tube anode, plus a bremsstrahlung continuum: the electron spot source has to be extremely small ($30\ \mu\text{m} \times 30\ \mu\text{m}$ in FWHM) to ensure a required vertical collimation HEW below 1 arcsec. Micro-focus sources of this kind are available on the market: some models generate a copious X-ray flux (on the order of 10^{11} ph/sec/sterad). The energy of the $K\alpha_1$ X-ray line depends on the anode material: BEaTriX 2.0 will include two X-ray sources, each one emitting its characteristic spectrum through its specific chain of optical elements: one equipped with an aluminum anode (for the 1.49 keV line) and the other with a titanium anode (for the 4.51 keV line).

3.2 The collimating mirror

We already procured [15] two mirrors from Zeiss in fused quartz HOQ 310, one lapped (shape: $PV < 5\ \mu\text{m}$, roughness: $\text{rms} < 0.5\ \mu\text{m}$) the second one grinded (shape: $PV < 15\ \mu\text{m}$, roughness: $\text{rms} < 2\ \mu\text{m}$), with a focal length of 4750 mm. The size of these mirrors is 456 mm x 100 mm x 50 mm, with the optical portion of 436 mm x 60 mm, and a grinded area of 456 mm x 80 mm. The final polishing of the mirror will be done in a way to enlarge, if possible, the vertical optical area from 60 to 66 mm, in order to fulfill the ESA requirement of 66 mm in section. The polishing and final figuring will be done in house, at INAF-OAB, aiming at achieving a maximum tolerable HEW of 0.5 arcsec. The mirror will be subsequently coated with a platinum layer (30 nm) and an amorphous carbon over-coating (3 nm) to enhance at most the reflectivity also at low-energy X-rays [17]. Once complete, the mirror will ensure a collimated and parallel reflected beam, with a horizontal size of 4 mm and a vertical size of 60-66 mm. The *vertical* collimation, at this stage, is solely determined by the source size and the focal length ($0.57 \times 30\ \mu\text{m}/4750\ \text{mm} = 0.74$ arcsec, where 0.57 is the HEW/FWHM ratio in a Gaussian) because it is essentially unaffected by out-of plane deviations in grazing incidence. The expected *horizontal* collimation stems from the incoherent convolution of the source and the mirror HEW, yielding 1.1 arcsec.

3.3 The crystals

Symmetrically-cut crystals (i.e., with diffracting planes parallel to the outer surface) are used in BEaTriX to monochromate the beam, followed by asymmetrically-cut crystals to expand the beam in the horizontal direction. Two types of crystals are envisaged for BEaTriX: Si(220) crystals for the 4.51 keV line, and Ammonium Dihydrogen Phosphate - ADP(101) crystals for the 1.49 keV line.

While silicon crystals are widespread in X-ray optics and their fabrication is well known, ADP crystals are more challenging. To our knowledge, only Saint Gobain can deliver at a commercial level this kind of crystals. In this respect, there are some constraints related to this type of crystals:

- maximum size: Saint Gobain can produce monolithic crystals only up to a maximum size of 120 mm x 80 mm. Therefore the 1.49 keV expanded beam will be limited in size to about 120 mm (unless adopting a more complex configuration based on multiple crystals);
- only single crystals in ADP can be produced, not Channel Cut Crystals (CCC);
- heating of the ADP crystal is not recommended above 50 °C. For this reason, baking of the tubes with the optical components cannot be considered. Anyway, outgasing is not expected to play an important role at 10^{-3} mbar.
- the intrinsic mosaic structure of the crystal (that may affect the degree of achievable monochromation) is not yet well known and it has to be investigated.

A sample of the organic ADP crystal has been just purchased and tests are foreseen to check the planarity of the crystalline planes and make sure that its mosaic structure is compatible with a final beam divergence of 1.5 arcsec. This is essential for the second phase of the project, when the 1.49 keV beam line is implemented.

3.3.1 The new monochromation stage

BEaTriX 2.0 includes a major change in the monochromator system. Due to dispersivity of asymmetrically-cut crystals [18], the horizontal collimation will mostly depend on the spectral bandwidth of the beam as out of the monochromator. In this section, we report the analysis performed on the beamline at 4.51 keV, which uses the Si (220) crystals. Similar

considerations apply to the 1.49 keV beamline, where the ADP crystals are used: appropriate simulations have still to be performed to assess the quality of the beam. Simulations have been performed using the widespread code SHADOW (commonly used for simulations of X-ray optics for synchrotron radiation experiments [19]) in the OASYS package and, in order to return an absolute evaluation of the flux intensity per cm^2 at the sample, via an ad-hoc developed IDL-based ray-tracing code. The results are in good agreement (Fig. 4).

Owing to the dispersivity of the asymmetric crystal, a monochromatization better than 0.1 eV has to be reached in order to achieve 1.5 arcsec also in the horizontal collimation. A monochromatization performed with only two diffractions using parallel, symmetric crystals would return, after the beam expansion, an horizontal HEW of about 9 arcsec; a lower value of 3 arcsec (but still not fulfilling the requirement) would be reached with a tilt of 11 arcsec of the first crystal. A reduction in the horizontal divergence can be obtained, in contrast, using four symmetrical crystals plus a rigid rotation of the first pair of crystals (Fig. 3) with respect to the second pair.

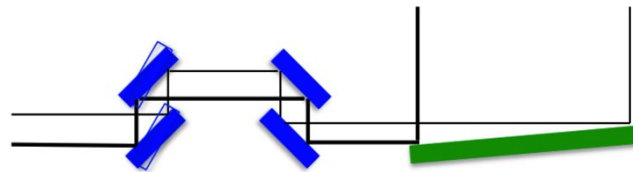

Figure 3: Optical layout of the monochromator (blue) and the beam expander (green). The crystal for monochromatization are symmetrically cut, the one for the beam expander is asymmetrically cut. Monochromatization with four diffractions, with a possible rigid rotation of the first pair of crystals to detune the rocking curves and so shrink the passing band.

Figure 4, left, shows that with four reflections on symmetric crystals, and a 10 arcsec tilt of the first crystal pair, a horizontal divergence of 1.4 arcsec can be reached. This enables the utilization of a pair of CCCs, a configuration that largely simplifies the movement system, and also giving the possibility to optimize either the horizontal divergence or the flux. Fig. 5 shows the results in terms of bandwidth of the beam emerging from the monochromator. A highly monochromatic beam is obtained (0.03 eV at 10 arcsec tilt) at the expenses of photon loss (Fig. 4, right), but this is essential to minimize the horizontal divergence, due to the energy dispersive properties of the asymmetrically cut crystal. Nevertheless, the expected intensity of the beam at the sample, based on the X-ray source intensity, can be assessed as 10 ph/s/cm^2 , a flux that enables a SPO MM characterization in a ~ 30 min integration.

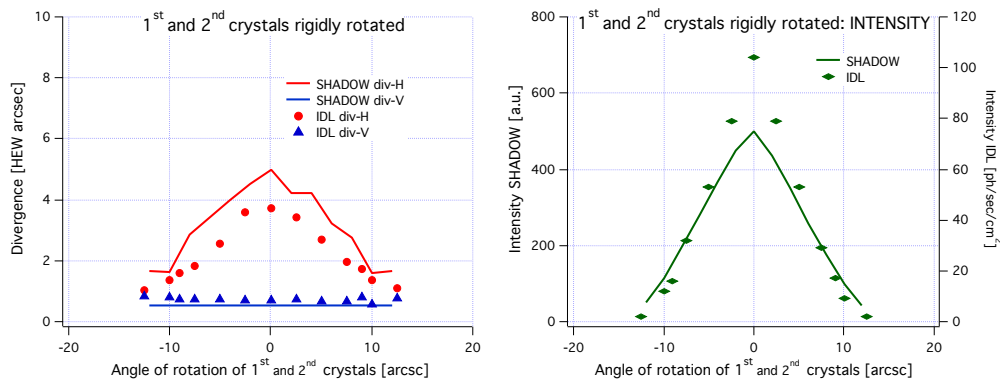

Figure 4: Effect of the tilt of the 1st and 2nd parallel symmetric-cut crystals. Left: Vertical (blue) and horizontal (red) divergence. Right: Intensity loss. Note that the SHADOW result is given in arbitrary units while the result from the IDL code is given in ph/s/cm^2 .

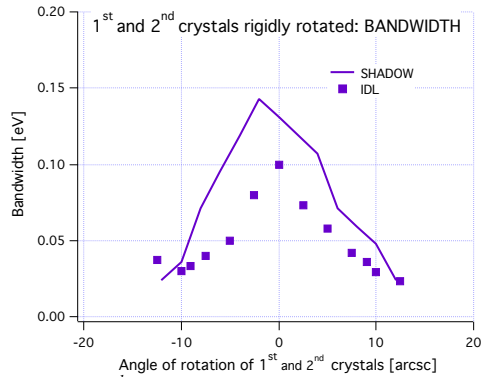

Figure 5: Effect of the tilt of the 1st and 2nd crystals. Bandwidth of the beam emerging from the monochromator

3.3.2 The beam expander

An asymmetrically cut crystal in Silicon for the 4.51 keV setup has been already realized. A 20-cm diameter, 5 cm high cylinder in monocrystalline, high-purity silicon was purchased from the MEMC company [15]. The crystal has been cut at CNR-IMEM, an institute with a very long experience in X-ray diffracting crystals, using a circular diamond saw. The cut crystal has size of 170 mm x 60 mm x 20 mm. It was subsequently polished, to remove the lattice damage introduced by the cutting process at the crystal surface. The resulting crystal has been tested in X-rays at CNR-IMEM, showing that the crystal cutting was correct (44.592 deg, versus a specification of 44.5 ± 0.1 deg) and that the rocking curve is almost identical to the one of a perfect crystal (i.e., no residual damage was left in the crystalline lattice).



Figure 6: the beam expander crystal for the 4.51 keV setup, monocrystalline silicon, with the proper asymmetric cut at 44.59 deg from the (220) planes. The surface has been polished to remove the lattice damage introduced by the cut. The crystal dimensions are 170 mm x 60 mm x 20 mm

4. MECHANICAL DESIGN OF THE FACILITY

4.1 Modification in the mechanical design of the facility

BEatriX is designed as an L-shape [15], where the short arm is used for beam moderation, and the long arm propagates the beam to ATHENA's nominal focal plane, at 12 m distance from the MM. The long arm has to be moved in the vertical plane, for the detector to follow the focused beam, directed downwards by the double reflection on the MM, with an angle determined by the radius of the MM. The previous mechanical design of BEaTriX [15], was envisaging the switching from 1.49 to 4.51 keV, by:

- using a single X-ray source, which can provide both energies;
- selecting the energy by translating the proper monochromator into the X-ray beam;

- translating the proper beam expander into the beam;
- orienting the short arm in order to impinge on the crystal at the proper angle and to produce and expanded beam travelling in the direction of the detector.

This previous configuration (Fig. 7, left) required very tight specifications for the motors, since they had to be highly repeatable. We have so been working on a second configuration (Fig. 7, right), where the lines for the two energies are simultaneously present and aligned since the beginning (with periodical maintenance). In this way, no alignment is required after switching from one energy to another. This second configuration differs from the previous one for the following hardware components:

- two short arms,
- two X-ray sources,
- two parabolic mirrors,
- relaxed motor specifications (only resolution is required while repeatability is not necessary).

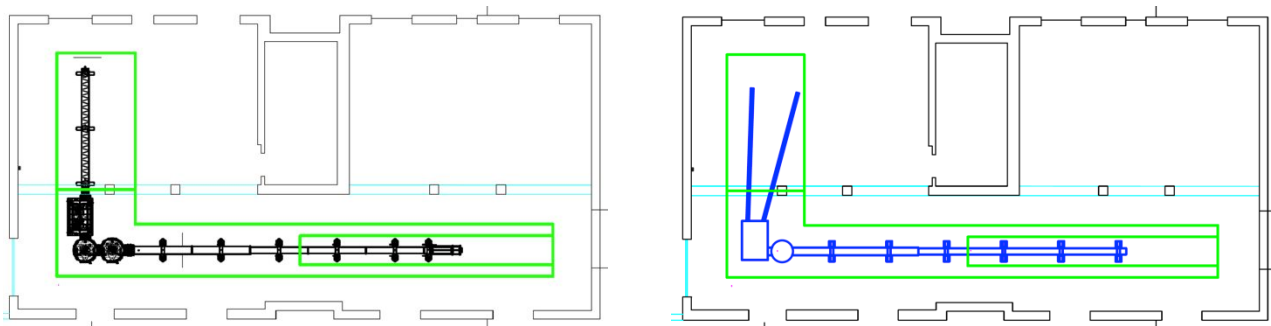

Figure 7: Left: previous design of the BEaTriX 1.0 facility. Right: present design of BEaTriX 2.0.

BEaTriX 2.0 is considered the best solution for the throughput of 3 MM/day, preserving the alignment when switching from one energy to the other. Only the 4.51 keV line will be fully implemented in this first phase, to demonstrate the concept, while the second energy will be implemented in a second phase.

4.2 Conceptual design of the BEaTriX 2.0 vacuum system

In Figure 8, the conceptual design of the BEaTriX 2.0 vacuum system is presented. The X-ray micro-focus sources are positioned at the beginning of the short arms. They are mounted on a support structure (the so-called “source tower”) that provides the needed stability to the X-ray sources, decoupling them from the short arms by means of bellows, and also enabling their manual alignment. The short arms are able to rotate in the horizontal plane, by ± 1.5 deg for proper alignment.

The tubes providing the short arms are approximately 4700 mm long. The distance from the parabolic mirror and the X-ray source and its tolerance ($4750 \text{ mm} \pm 1 \text{ mm}$ tolerance along the optical axis) results in relaxed specs for the temperature gradients. In fact, the $\pm 1^\circ\text{C}$ variation of the laboratory temperature would produce a variation of just $\pm 80 \mu\text{m}$ over the 4700 mm length of the stainless steel tube (assuming a $\text{CTE}_{\text{AISI-304}} = 17 \cdot 10^{-5} \text{ K}^{-1}$), i.e. well below the tolerance.

A simple rectangular tank will host the three optical components responsible for the beam moderation and their motorizations. In the first phase of the project, only the 4.51 keV beam line will be fully equipped, while in a second time also the 1.49 keV line will be implemented. An X-ray beam monitor will be mounted in the path of the beam emerging from the beam expander, in order to measure the stability of the flux. A phosphor window will image the beam for making easier the alignment. Finally, the tank is equipped with vacuum valves on both ends and a vacuum pump system, in order to make it a vacuum independent sector in case of necessity.

The next chamber encloses the MM under test. It will host the motors that enable the MM alignment and a thermal box to perform thermal cycles of the MM in the $20 \pm 30^\circ\text{C}$ range. The thermal box will be designed in order to radiatively heat/cool the MM. A lateral porthole is present for sample removal/mounting. This section is equipped with vacuum

valves on both ends and an independent vacuum pump in order to vent/evacuate only this section when the sample is changed (30 min are allocated for the evacuation of this tank, to go at the test rate of 3 MM/day).

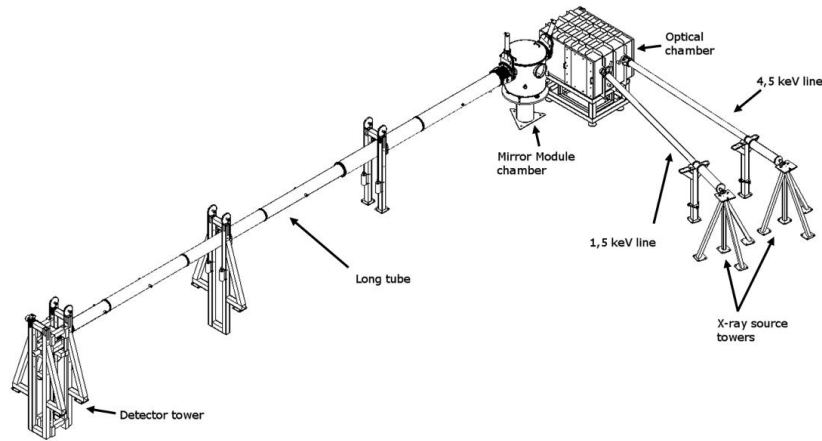

Figure 8: Conceptual design of the BEaTriX 2.0 vacuum system.

A 12-m long tube finally allows the X-rays to propagate to the focal plane, after reflection on the module under test. The tube consists of separated joints, connected to each other via vacuum flanges. The long arm evacuation is ensured by its own vacuum pump system. The tube is held by proper supporting systems, aimed at not transmitting possible vibrations to the detector tower.

A solid structure tower is fixed to the foundation in order to support the X-ray camera and its motorization (XYZ) stage. It should be noted that this tower is also connected to the end of the long tube, allowing the movement downwards in vertical direction. A bellow guarantees the XYZ movements of the X-ray camera. The translation along X is needed for the focus search, while those in Y and Z are used to cover the area of the collimated beam, and to calibrate it in divergence and uniformity, when the tube is positioned in the horizontal position.

4.3 Condensation and contamination control

At 10^{-3} mbar, condensation occur at about -70°C . Since the detector will operate at -20°C and the minimum temperature for the MM will be -10°C , no condensation is expected either on the detector or on the MM, during operation.

Condensation can in principle occur during evacuation or venting, when the gas is expanding and, therefore, also cooling. Proper evacuation speed will avoid condensation during evacuation, and venting with nitrogen (or filtered/dehumidified air) will avoid condensation during venting.

For what concerns the contamination, the presence of particles will produce a loss in the Effective Area. 1% loss is allocated for the testing in BEaTriX, which corresponds to a contamination of 25 ppm [20]. From [21], this is translated into ISO class level. The following table reports the Particle Fall Out (PFO) per day, as function of the ISO level. The contamination level for a 3h time is also reported: 3h is the expected permanence time of the MM inside BEaTriX for testing. These numbers will drive the selection of the clean tent around the MM, the motorization and the valves.

Table 2: PFO as function of ISO level and time.

ISO	PFO ppm/day	ppm/3h
4	0.4	0.05
5	1.9	0.2
6	10	1.3
7	52.3	6.5

5. THE LABORATORY: PROJECT AND REALIZATION

BEaTriX is being built over the ground basement of a building already present at the Brera Observatory in Merate. The bottom floor of the building is now in the renovation phase, and will soon be completed, based on a project we have commissioned to BCV-progetti (Milano, Italy). The study was driven with the goal of constructing a stable foundation that will isolate the beam line from vibrations due to the environment, anthropic-noise sources and vacuum pumps. The entire design, both for the instrument and for its foundation, has to take into account stability considerations to have a system insensitive to vibrations at least at the level of the CCD pixel size (13.5 μm).

The basement of the instrument is designed in order to enable the movement of the long arm, and follow the focused beam, deviated downwards by the double reflection on the MM deviation. For this reason, the floor is lowered (Fig. 9) in an appropriate area of the laboratory.

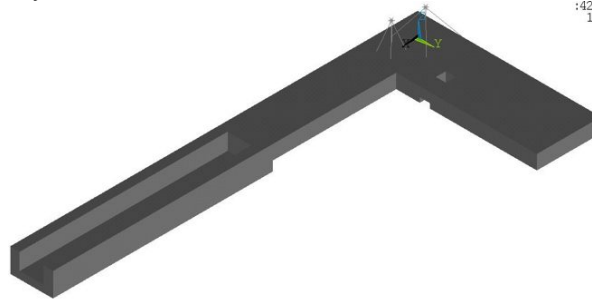

Figure 9. BCV design of the BEaTriX foundations

Input for the BCV analysis were obtained from a vibration measurement campaign performed on the ground where the laboratory is being built, and commissioned by OAB to Teknoprogetti Engineering (Vimercate, Italy). Two different measurements were performed:

- 1) soil vibration measuring with accelerometers followed by spectral analysis;
- 2) seismic survey by MASW (Multichannel Analysis of Surface Waves) technique, to dynamically characterize the soil.

The spectral analysis showed vibrational frequencies higher than 13 Hz, with maximum displacement of the ground of the order of 10 nm, caused to anthropic sources, setting the ground vibrations as negligible with respect to the pixel size. The amplitude of the vibrations has been confirmed by the data registered with the accelerometers positioned close to the telescope domes of the Merate site, and routinely used to measure frequencies and amplitudes of the earthquake by INGV (Istituto Nazionale di Geofisica e Vulcanologia).

The MASW data, obtained on the ground very close to the BEaTriX building, produced data necessary to characterize the elastic properties of the soil in dynamic range to achieve data for the soil modeling.

5.1 Design of the foundations

In the design of a foundation for an instrument sensitive to vibrations, the typical approach is to design a rigid block (therefore with high frequencies in free condition) placed on “soft” devices (elastomeric pads or springs, with relatively small damping factor ζ) resting on proper under-foundation slab.

Actually, a rigid foundation block cannot be realized, as the BEaTriX laboratory is hosted in an existing building, and only a limited depth could be dig for stability reasons of the building, unless expensive underpinning work are carried out on existing building foundation. A block as thick as possible was designed, leading to a total thickness of 60cm (foundations) + 30cm (under-foundation slab). With such a thickness, the foundation block, being very long, showed quite low frequencies in free-free conditions (Fig. 9).

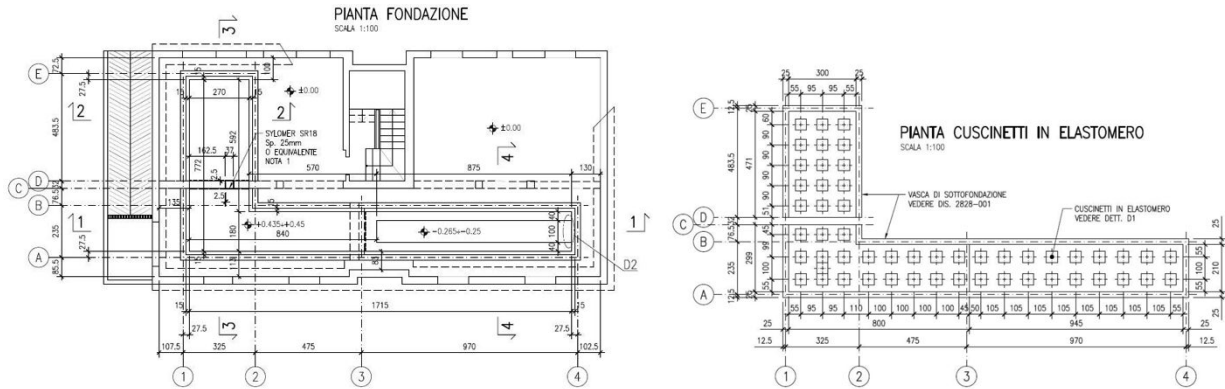

Figure 10 Left: BEaTriX foundations inside the renovated laboratory. Left (foundations): the short arm is 7.72 m long; the long arm is 17.15 m long. Left (under-foundations): the short arm is 8.52 m long; the long arm is 17.95 m long. Right: the 53 elastomers positioned in between the foundation and the under-foundation.

Since, at the time of the foundations design, the BEaTriX equipment design was not fully completed, and therefore the equipment frequencies were not known, the risk of resonance conditions between the equipment and the foundation block frequencies, or the soil and foundation frequencies could not be completely neglected. Therefore, an approach different than the typical methods was adopted and stiffer elastomeric pads have been placed between the foundation block and under-foundation slab. In this way the natural frequencies of the system are increased. Moreover elastomeric pads, with a very high damping factor, were considered (Syloodamp SP300, with $\zeta = 0.235$, and mechanical loss factor = 0.47). In total 53 blocks of size 500 mm x 500 mm x 25 mm were placed between the under-foundations and the foundations (Fig. 10 – right). In this configuration, any oscillation below the resonance level would be transmitted to the instrument with no significant magnification. On the other hand, oscillations around the resonance condition would be amplified only by a small amount ($2\times$), due to the high damping factor. Finally, frequencies 1.4 times above the resonance would be just damped.

6. CONCLUSIONS

The BEaTriX X-ray facility is in the realization phase at the Brera Observatory in Merate/INAF. BEaTriX will generate a broad, monochromatic, parallel, collimated, and polarized X-ray beam in a small space, working at two energies (4.51 and 1.49 keV). Once completed, BEaTriX will provide us with the capability to perform the X-ray acceptance tests of the ATHENA MMs, at the rate of 3 MM/day. Also other applications requiring a broad and parallel beam of soft X-rays can be envisaged.

The laboratory that will host BEaTriX is almost completed. The foundation of the instrument has been designed in order to isolate the beam lines from vibrations due to the environment, anthropic sources and vacuum pumps. With respect to previously published papers, the instrument design is evolved in some parts, in order to fully meet the requirements. The vacuum level was changed from 10^{-2} to 10^{-3} mbar in order to have a stable vacuum level also for the 1.49 keV X-ray energy beam. The monochromator stage was changed from 2 to 4 reflections on symmetrically cut crystals, in order to compensate for the energy dispersive properties of the asymmetrically cut crystal (the beam expander). This will be achieved by using a couple of channel-cut crystals (CCC). A tilt of the first CCC element with respect to the second will allow us to sufficiently reduce the energy band-width and, consequently, to achieve a horizontal divergence of the beam in accordance to the required 1.5 arcsec. This is obtained at the expense of flux intensity. In this respect, divergence and flux can be tuned, and an acceptable trade-off will be found to perform the tests. Finally, the mechanical layout has been optimized, preferring two fixed beam lines in order to reduce the risk of misalignments when switching from one energy to the other.

ACKNOWLEDGMENTS

The development of the BEaTriX facility is funded by the ESA contract No. 4000123152/18/NL/BW, “Advanced and

Compact X-ray Test facility for the ATHENA SPO module”, the AHEAD consortium activities financed by the EU Horizon 2020 grant No. 654215, and INAF internal funds. We thank Finn E. Christensen (DTU, Denmark) for very useful discussions.

REFERENCES

- [1] Nandra, K., Barret, D., Barcons, X., et al., “The Hot and Energetic Universe: A White Paper presenting the science theme motivating the *Athena* mission”, <http://arxiv.org/abs/1306.2307> (2013)
- [2] Willingale, R., Pareschi, G., Christensen, et al., “Science requirements and optimization of the silicon pore optics design for the Athena mirror,” Proc. SPIE 9144, 91442E (2014)
- [3] Collon, M.J., Vacanti, G., Barrière, N.M., Landgraf, B., Günther, R., et al., “Development of ATHENA mirror modules,” Proc. SPIE 10399, 103990C (2017)
- [4] Collon, M.J., Vacanti, G., Barrière, N.M., Landgraf, B., Günther, R., et al., “Silicon pore optics mirror module production and testing,” Proc. SPIE 10699, this conference (2018)
- [5] Vacanti, G., Barrière, N.M., Bavdaz, M., Chatbi, A., Collon, M.J., et al., “Measuring Silicon Pore Optics”, Proc. SPIE 10399, 103990N (2017)
- [6] Valsecchi, G., Bianucci, G., et al., “Results of SPO mirror modules optical integration in the ATHENA telescope”, Proc. SPIE 10699, this conference (2018)
- [7] Vernani, D., Bavdaz, M., Wille, E., et al., “Integration of the ATHENA mirror modules: development status of the indirect and direct x-ray methods”, Proc. SPIE 10699, this conference (2018)
- [8] Burwitz, V., Willingale, R., Pellicciari, C., et al., “Developing, testing, and calibrating the ATHENA optics at PANTER”, Proc. SPIE 10399, 103990O (2017)
- [9] Krumrey, M., Muller, P. et al., "New X-ray parallel beam facility XPBF 2.0 for the characterization of the silicon pore optics," Proc. SPIE 9905, 99055N (2016)
- [10] Menz, B., Brauningner, H., Burwitz, V., Hartner, G., Predehl, P., "Studying ATHENA optics with divergent and collimated x-ray beams," Proc. SPIE 9144, 91445J (2014)
- [11] Christensen, F., Hornstrup, A., Frederiksen, P., et al., "Expanded beam x-ray optics calibration facility at the Daresbury Synchrotron," Proc. SPIE 2011, 540 (1994)
- [12] Spiga, D., Pareschi, G., Pellicciari, C., et al., “Functional tests of modular elements of segmented optics for x-ray telescopes via an expanded beam facility,” Proc. SPIE 8443, 84435F (2012)
- [13] Spiga, D., Pellicciari, C., Bonnini, E., et al., "An expanded x-ray beam facility (BEaTriX) to test the modular elements of the ATHENA optics," Proc. SPIE 9144, 91445I (2014)
- [14] Pellicciari, C., Spiga, D., Bonnini, E., et al., “BEaTriX, expanded soft x-ray beam facility for test of focusing optics, an update,” Proc. SPIE 9603, 96031P (2015)
- [15] Spiga, D., Pellicciari, C., Salmaso, B., et al. “Design and advancement status of the Beam Expander Testing X-ray facility (BEaTriX),” Proc. SPIE 9963, 996304 (2016)
- [16] Burwitz, V., Willingale, R., Pareschi, G., et al., “AHEAD joint research activity on X-ray optics”, Proc. SPIE 10699, this conference (2018)
- [17] Cotroneo, V.; Spiga, D.; Barbera, M.; Bruni, R.; Chen, K.; Marcelli, C.; Pareschi, G.; Romaine, S.; Zhao, Y. D.; Zheng, L.; Wu, Z. Y, Carbon overcoatings for soft x-ray reflectivity enhancement, Proceedings of the SPIE, Volume 5536, pp. 49-60 (2004).
- [18] Sanchez del Rio, M., Cerrina, F., “Asymmetrically cut crystals for synchrotron radiation monochromators”, Review of Scientific Instruments 63, 936 (1992)
- [19] M. Sanchez del Rio, N. Canestrari, F. Jiang, F. Cerrina, *SHADOW3: A New Version Of The Synchrotron X-Ray Optics Modelling Package*, Journal of Synchrotron Radiation, 18, 708-716 (2011)
- [20] ESA-ATHENA-ESTEC-PL-DD-0001, “ATHENA - Telescope Reference Design and Effective Area Estimates”, (16/02/2018)
- [21] ECSS-Q-ST-70-01C, “European Cooperation for Space Standardization. Space product assurance. Cleanliness and contamination control”, (2008)