



Publication Year	2019
Acceptance in OA	2021-02-23T15:37:39Z
Title	The AGILE gamma-ray satellite software system: real-time analysis and Apps for multi-wavelength and multi-messenger astronomy
Authors	Bulgarelli, A.
Publisher's version (DOI)	10.1007/s12210-019-00860-2
Handle	http://hdl.handle.net/20.500.12386/30560
Journal	RENDICONTI LINCEI. SCIENZE FISICHE E NATURALI
Volume	30

The AGILE Gamma-Ray satellite software system: Real-Time Analysis and Apps for multi-wavelength and multi-messenger astronomy.

Andrea Bulgarelli

Received: date / Accepted: date

Abstract I describe in this paper the AGILE Real-Time Analysis (RTA), that is the software system developed for the AGILE γ -ray Mission operations and scientific observations. Important tasks of the software include scientific alerts and follow-up observations in the multiwavelength and multi-messenger context. Key elements of the AGILE RTA are: a flexible software architecture, an efficient software management workflow, and an optimized team management implemented by the AGILE Team in more than twenty years of work. All these elements contributed to the success of the AGILE Mission, and they also constitute the basis for future projects of high-energy observatories. We also describe the smartphone APP *AGILEScience* that displays the scientific results of the Mission for professional and outreach purposes: it is an essential element of the AGILE Ground System and a unique "gate" to the γ -ray sky for the public audience.

Keywords observatory · data acquisition · gamma-ray

PACS 07.05.Hd · 07.05.Kf · 95.55.Ka

1 Introduction

AGILE (Astrorivelatore Gamma ad Immagini LEggero) [Tavani et al. 2009] is a mission of the Italian Space Agency (ASI) devoted to γ -ray and X-ray astrophysics in the energy ranges 30 MeV – 50 GeV, and 18 – 60 keV, respectively. AGILE was successfully launched on 23 April 2007 from the Indian space base of Sriharikota in a ~ 550 km equatorial orbit with low inclination angle, $\sim 2.5^\circ$. AGILE was the only mission entirely dedicated to high-energy astrophysics above 30 MeV during the April 2007-June 2008 period. The highly

A. Bulgarelli
INAF/OAS Bologna
Via Gobetti 93/3, Bologna (Italy)
E-mail: andrea.bulgarelli@inaf.it

innovative AGILE instruments are the first of the current generation of high-energy space missions based on solid-state silicon technology.

At the beginning of July 2007 the scientific verification phase of the γ -ray telescope was completed: AGILE was performing nominally, and scientific observations started. The pulsars Vela, Geminga and Crab were immediately detected and, in the week 24-30 July, AGILE observed the blazar 3C 454.3. The flux of the source rapidly increased, and 3C 454.3 soon became one of the brightest sources of the γ -ray sky. An early version of an automated processing system allowed the AGILE Team to follow the phenomena during the observation, and the first Astronomer's Telegram was issued immediately [Vercellone et al. (2007)]. This experience was one of the main drivers for the development in the following years of the **AGILE Real-Time Analysis (RTA)**, a software pipeline to follow the γ -ray sky in real-time.

The data flow is described in Sect. 2. Sect. 3 describes the reconstruction software and the Science Tools, that are the building blocks of the AGILE Real-Time Analysis. The AGILE Real-Time Analysis is described in Sect. 4 and 5 together with the transient γ -ray sky follow-up strategy.

2 The data flow

AGILE scientific data (about 300 Mbit/orbit) are sent from the satellite to the ASI ground station in Malindi (Kenya) at every satellite passage (about 96 minute period) in telemetry data format, and relayed in one LV0 file, at the end of the passage, to the AGILE Mission Operation Centre (MOC) managed by Telespazio at Fucino (L'Aquila). From MOC, each file is transferred through ftp to the ASI Space Science Data Centre (SSDC) in Rome. Here, each file is routinely archived and converted to a FITS format called LV1 data (preprocessed data) by the AGILE Telemetry Preprocessing System - TMPPS [Trifoglio et al. (2008)]. LV1 data are converted in COR files in order to apply a temporal correction. Data are further processed in SSDC to produce LV2, i.e. the EVT files (the photon list) and LOG files that describe the status of the satellite. Scientific processing produces LV3 data, or sky maps, using the Science Tools developed by the AGILE team (see Sect. 3) and then integrated into the pipeline systems for quick look monitoring and consolidated archive generation. Upon creation, in the first version of the AGILE Real-Time Analysis the LV1 data was forwarded from SSDC to the INAF/OAS site [Trifoglio et al. (2013)] where they was processed by AGILE Real-Time Analysis pipelines. With the new version of the AGILE Real-Time Analysis the COR and LV2 data are forwarded from SSDC to the INAF/OAS site.

The full AGILE Real-Time Analysis is distributed between SSDC and INAF/OAS Bologna, as described in Sect. 4 (the first version, in operation until 2016) and Sect. 5 (the new version, in operation since 2016).

A backup chain has been setup in order to guarantee the LV1 input data to these RTA pipelines in case of problems in the MOC-SSDC-OAS data links and/or at SSDC site. Provided the authorisation of the Mission Director, this

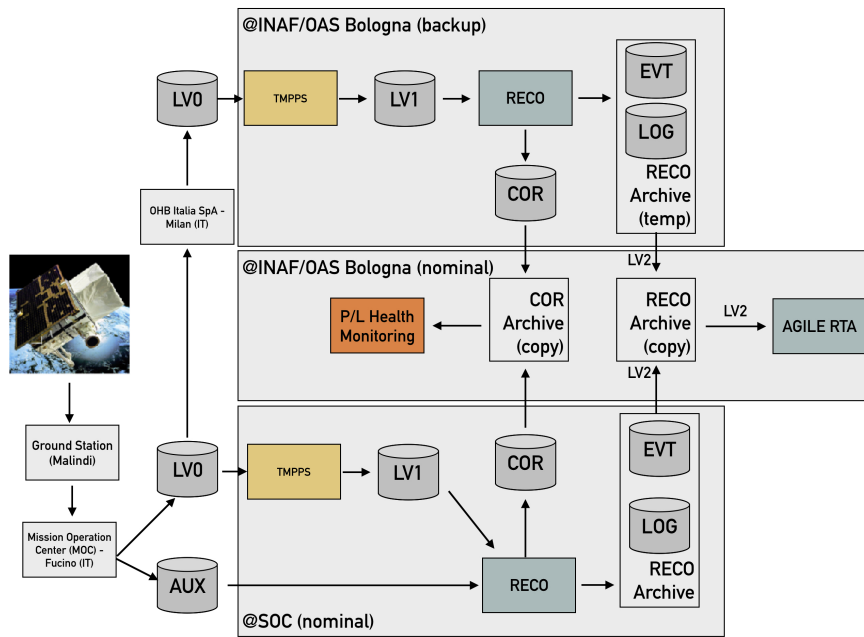

Fig. 1 The data flow from LV0 to LV3 for the second version of the AGILE Real-Time Analysis. TMPPS and RECO runs at SOC in SDC and produce a COR and a RECO Archive that are transferred to INAF/OAS Bologna. A backup chain from Telespazio to OHB Italia SpA (formerly Compagnia Generale dello Spazio (CGS)), Milan is also present. The P/L Health monitoring is used by MOC people to check the status of the P/L.

backup chain runs at INAF/OAS a copy of the TMPPS pipeline to generate and provide the LV1 files to the RTA pipelines also in case of problems in the nominal chain. It retrieves the LV0 files that are routinely sent by MOC to an ftp server located at OHB Italia SpA in Milan to allow OHB to perform satellite troubleshooting in case of need.

Fig. 1 reports the data flow from LV0 to LV3 for the second version of the AGILE Real-Time Analysis, from MOC to the INAF/OAS Bologna site.

A very important aspect of the AGILE software system is that the data formats were defined in the initial phases of the project (before the start of the AIV phase), using standard astronomical data formats, and since then they have not been changed, allowing the AGILE Team to develop and maintain the AGILE software system in an iterative and incremental way, with a development process lasting 20 years and still ongoing.

3 The Reconstruction software and the Science Tools

In the context of the AGILE project a software framework called Science Console (a.k.a. Instrument Workstation) [Trifoglio et al. (2000), Gianotti et al. (2001),

Bulgarelli et al. (2003)], a Linux workstation connected to the Payload EGSE (Electrical Ground Support Equipment), has been extensively used to support the assembly, integration and verification (AIV) activities carried out on the AGILE instrument, from unit to payload during level, the calibration campaign (at the Frascati facility in 2006), the qualification campaign (in the period 2006 June-July and February-March, 2007 at the IABG facility in Munich (Germany)), launch campaign and in-orbit commissioning. The AGILE Team, including the software developers, took an active part in the AGILE construction and calibration phases. This approach allowed to maximise the effectiveness of the work performed during the construction phase, in which the AIV software became a fundamental part of the AGILE Real-Time Analysis.

The reconstruction software and the Science Tools (the latter developed at INAF/IASF Milano along with some components of the reconstruction pipeline) are other building components of the Real-Time Analysis. The reconstruction software (a.k.a. RECO) is composed of the standard analysis (**RECO-STD**) and the **on-ground event filter**. The standard analysis provides a timing correction of LV1 files and provides a track reconstruction algorithm, used for energy estimation and event direction reconstruction. The AGILE-GRID **on-ground event filter** [Bulgarelli et al. (2019)] assigns a classification flag to each event acquired by the GRID instrument depending on whether it is recognised as a γ -ray event (*gamma*), a charged particle (*particle*), a single-track event (*single*), or an event of uncertain classification (*limbo*). The selection is done on a majority vote on the result of several decision trees, which are all derived from the same training sample by supplying different event weights during the training. Two on-ground event filters was developed: FT3ab and FM3.119 (that includes the F4 filter developed at INAF/IASF Milano [Giuliani et al. (2006)]).

Finally, the event direction in sky coordinates is reconstructed and reported in the AGILE event files (EVT), excluding events flagged as charged background particles. The Level-2 (LV2) archive of LOG and EVT files is then produced.

Fig. 1 shows the role of the RECO software in the data flow from LV0 to LV3 for the second version of the AGILE Real-Time Analysis.

The AGILE Science Tools [Chen et al. (2011)] are the tools necessary to analyse AGILE data starting from LOG and EVT files (LV2). They provide a way to generate counts, exposure and diffuse emission maps (LV3) that are used as input for the binned maximum likelihood estimator (MLE). The result of the MLE is an evaluation of the presence of one or more point-like sources in the sky maps [Bulgarelli et al. (2012a)]: this is the essential step for the scientific results of AGILE.

Another key aspect was the development of the satellite and data handling simulators, that allowed to start the development of the software in the early stage of the satellite development. More details on the AIV software and its evolution to the Ground Segment and the role played by satellite simulators is presented in [Bulgarelli et al. (2019b)].

4 The first version of AGILE Real-Time Analysis and the transient sky in the multiwavelength context

To understand the variability of the γ -ray sky is necessary to follow the sky in real-time. The search for γ -ray transients is one of the major activities performed by the AGILE Team, with a monitoring program and a dedicated alert system that is implemented within the AGILE Ground Segment, distributed between SSDC and INAF/OAS Bologna and called the AGILE Real-Time Analysis (RTA).

In the last sections, we have described some building blocks used for the development of this system, most of them developed during the construction phase. In particular, some design choices played a fundamental role: the early decision of the final data format, the development of the P/L simulators, the full reuse of the AIV software in the Ground Segment, the organisation of the AGILE Team during the construction phase, the reconstruction software and the Science Tools.

These elements allowed the AGILE Team to have an automatic scientific data analysis system running immediately after the launch. The first version of this system (2007-2016) was devoted to search for γ -ray transients detectable on timescales of 1-2 days in the AGILE-GRID data (with a dedicated Flare Advocate team), and to search for GRBs detected with MCAL and SA (with a Burst Advocate team).

After the launch the AGILE Team began the development of the first system of data analysis in real-time, with the components as building blocks described in the previous sections.

Two automatic systems, for analysing AGILE-GRID scientific data were created. The first system in Bologna, the **AGILE-GRID Science Alert System** [Bulgarelli et al. 2014], maximises the speed of reaction, even at the cost of losing something on the data quality, and starts immediately as new data arrives, generating alerts in near real-time. The second system [Pittori et al. 2013] in SSDC, the **Quick-Look Scientific pipeline**, maximises data quality, and for this reason, it performs a more in-depth analysis, twice a day. The two systems allow independent cross-checking, thus maximising the scientific return of AGILE. Once an alert has been generated, the Flare Advocate team works to confirm the results before publishing an Astronomer's Telegram.

At the start of the new automatic AGILE-GRID Science Alert System in Bologna, in September 2007 automated science alerts were generated from the Crab nebula region: a γ -ray flare from the Crab Nebula was detected for the first time. The AGILE PI decided to study this phenomena in a more deeper way. In the 1AGL Catalog [Pittori et al. 2009] it was pointed out that the average flux of the Crab Nebula was higher than expected.

In the second half of 2008 to the Bologna system was added the possibility to send alerts via text messages (SMS) on the mobile phones (see Fig. 2).

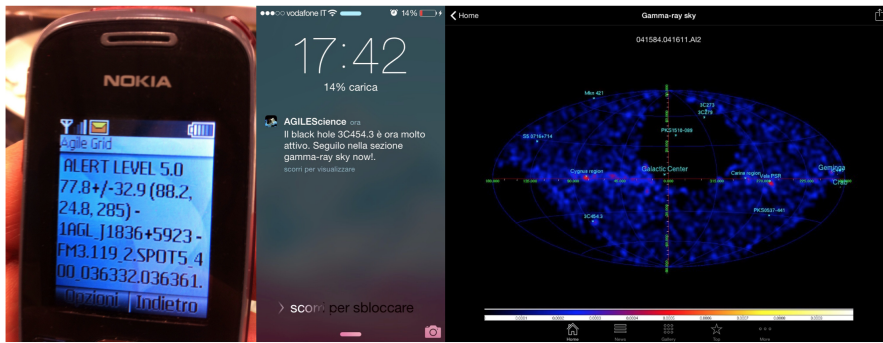

Fig. 2 From text messages (SMS) to push notifications and to γ -ray sky maps on tablets and Apps. Over the last few years, mobile technology has evolved and has changed the way we work and live. This evolution has been used to maximise the scientific return of AGILE.

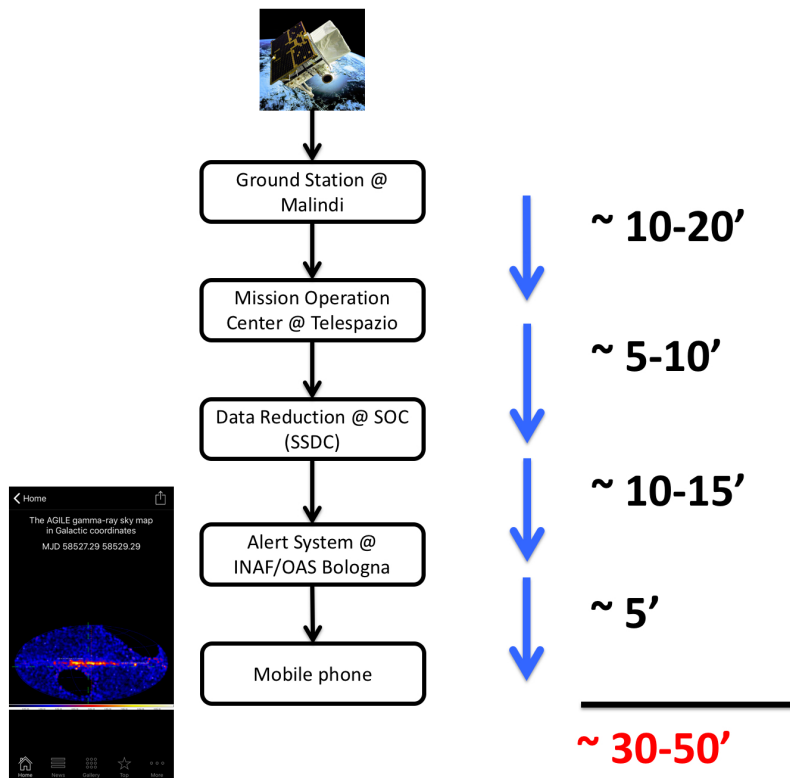

Fig. 3 Data transfer time of the Ground Segment from the AGILE satellite to science alerts to mobile phones and to the *AGILEScience* App.

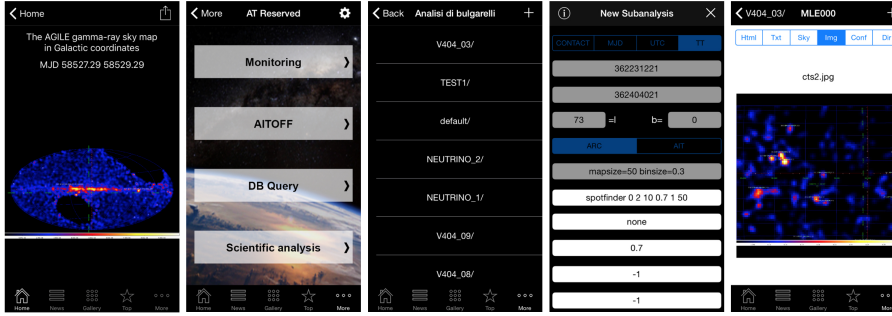

Fig. 4 The *AGILEScience* App. From left to right: (i) the Flare Advocate can check the γ -ray sky. If a candidate γ -ray flare is found it is possible to perform a manual scientific analysis to confirm the result. To perform the scientific analysis, (ii) the Flare Advocate goes in the "Scientific Analysis" section, (iii) where it is possible to create a new analysis or select an existing one, (iv) some parameters of the analysis must be inserted (e.g. integration time, position in the sky), and (v) the App shows the final result, analysed with the Maximum Likelihood Estimator, and the sky maps.

In 2011 the *AGILEScience* App for Apple^{1, 2} and Android³ mobile platforms was developed, thanks also to the help of the University of Modena. The App not only provides information, photos, videos and updates on the AGILE mission, but the primary purpose was to give all astronomy enthusiasts the chance to follow the γ -ray sky in real-time; the App shows the γ -ray sky map of our Universe as seen by AGILE-GRID, and updated every orbit. The Flare Advocates also use this feature. To achieve this goal, the App was connected to the Bologna system and subsequently, in 2013, to the Rome system.

The generation of alerts in 30-50 minutes after the ground contact was an absolute record for γ -ray missions of this type. All this is possible thanks to the flexibility of the AGILE Ground Segment. Fig. 3 shows the transfer time of the Ground Segment from the AGILE satellite to science alerts on mobile phones and to the *AGILEScience* App. In 2014 our App allowed the astronomy enthusiasts to follow, for the first time, the evolution of the 3C54.3's super-flare through push notifications (see Figure 2).

In 2015 we added a unique feature among all high-energy instruments: the possibility to perform a full scientific analysis with real-time data using only the App. This allows the Flare Advocate team to check the results of AGILE, to receive important science alert via push notification, and finally, to perform a scientific analysis for the confirmation of the results before publishing an Astronomer's Telegram, everything using only the App (see Fig. 4). This significantly decreased the reaction time of the AGILE Team in the context of the multi-wavelength astronomy.

¹ <https://itunes.apple.com/it/app/agilescience/id587328264?mt=8>

² <https://itunes.apple.com/it/app/agilescience-for-ipad/id690462286?mt=8>

³ <https://play.google.com/store/apps/details?id=com.agile.science>

In addition to the AGILE-GRID Science Alert System pipeline, the **AGILE GRB WebMon** was developed, for the GRID, MCAL and SA GRB detections [Bulgarelli et al. (2008b), Trifoglio et al. (2013)]:

1. the SuperAGILE Alert Pipeline runs at INAF/IASF Roma to search for GRBs, X-ray bursts and other transients in the hard X-ray band [Feroce et al. (2007)];
2. the MCAL Alert Pipeline [Marisaldi et al. (2008a), Marisaldi et al. (2008b)] runs at INAF/IASF Bologna and processes the data of the MCAL burst chain in order to identify valid burst on-board triggers and to search for both cosmic GRBs and valid Terrestrial Gamma-ray Flashes (TGF) candidates;
3. a dispatcher task handles GCN Notices received and the GRB alerts generated via e-mail by the above SA and MCAL Pipelines. These results are sent to the GRID GRB pipeline;
4. the GRID GRB pipeline searches for GRBs in the AGILE data by comparing the expected background with the counts in the first 60s, in a region of 15° of radius centred at the position of the burst.

The **AGILE P/L Health Monitoring** (see [Bulgarelli et al. (2008b)] for more details) is integrated into the same web interface with the MCAL and GRID GRB pipelines.

The AGILE-GRID Science Alert System, the Quick-Look Scientific pipeline, the AGILE GRB WebMon and the P/L Health monitoring and the App *AGILEScience* was the first version of the **AGILE Real-Time Analysis**. Figure 5 shows the workflow and the general architecture of the pipelines.

In October 18, 2009 one of the subsystems on board the AGILE spacecraft, the rotation wheel, suffered a malfunction that caused the satellite to leave its nominal pointing mode and switch to the spinning control mode. The work performed by the AGILE Team and by the space industries involved in AGILE to reconfigure the space mission started and on November 4, 2009 scientific operations restarted. The satellite scans the sky with an angular velocity of about 0.8° s^{-1}

The reorganisation of the on-ground software continued in the following months, and some GRB WebMon pipelines were switched off because it was no more possible to follow GRB with a rotating P/L. However, it is thanks to this new configuration that the most important discoveries of AGILE in the field of multi-wavelength astronomy have been possible in the AGILE-GRID energy range. The most important γ -ray flare was the Crab Nebula flare of September 2010. The γ -ray flux of the Crab Nebula was progressively increasing (following the sequence of alerts generated by the AGILE-GRID Science Alert System) and thanks to the mobile technology we followed the evolution of the phenomenon on our smartphones and checked the γ -ray sky maps in real-time. For this discovery Marco Tavani and the AGILE Team was awarded in 2012 the Bruno Rossi Prize of the American Astronomical Society (AAS). Fig. 6 shows the sequence of events of the 2010's Crab Nebula flare.

Until 2012 the main focus of the software developers was the optimisation of the AGILE-GRID Science Alert System pipeline and of the P/L Health

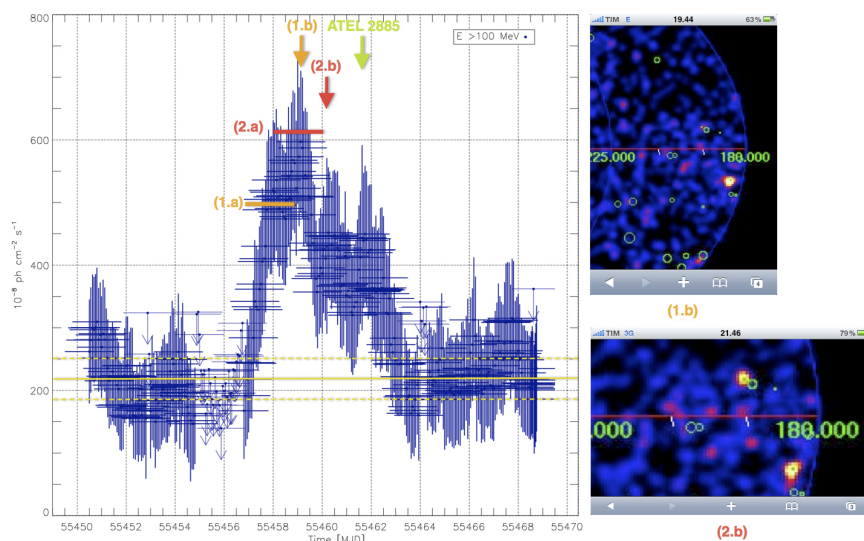

Fig. 6 96' sliding light curve (with two-day integration time) of the 2010 September Crab nebula flare as seen by the Bologna's AGILE-GRID Science Alert System. Errors are 1σ , and time is given in MJD. The yellow lines show the average Crab flux and the 3σ uncertainty range. 1.a and 1.b (in orange) are, respectively, the detected flux and the time of the alert generation by the Bologna pipeline when Crab nebula reaches a flux level that exceeds 1σ the mean flux level; on the right are the counts map of 1.b as seen by Bologna pipeline. 2.a and 2.b (in red) are related to the maximum flux level reached; on the right are the counts map of 2.b as seen by Bologna pipeline. The green arrow indicates the time that the Astronomer's Telegram was posted. More details in [Bulgarelli et al. 2014]

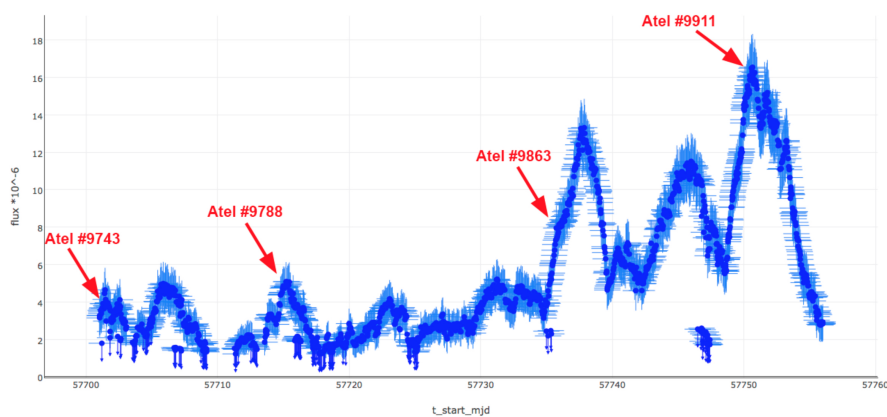

Fig. 7 An example of the use of the Data Warehouse. The figure shows the light curve associated with the science alerts generated by the CTA 102 position. Four of Astronomer's Telegrams have been published.

the spinning mode configuration. Thanks to this observing mode the capability of the AGILE satellite for the discovery of transients is unique: the current spinning configuration of the satellite, together with a large field of view and a good sensitivity provides coverage of 70% of the sky, with each position exposed for 100 seconds, 200 times a day. Thanks to this configuration, it immediately became evident that AGILE plays an important role in search of the γ -ray electromagnetic counterparts of gravitational waves, so the AGILE Team decided to evolve the AGILE Real-Time Analysis, to react to external GW or neutrino alerts. A full reorganisation of the AGILE pipelines was needed.

The development of the second version of this system started in 2015, after the first direct observation of a gravitational wave.

After some months of intense development, the first version of the AGILE Real-Time Analysis with an automated search of γ -ray electromagnetic counterparts of a GW was ready in October 2016, just before the start of the O2 LIGO/Virgo run. In addition, the reconstruction pipeline, running in SSDC has been optimised to further reduce the processing time up to the 20 minutes. New components have been developed for the management of external science alerts, two wake-up systems (**morfeo** and **hermes**) that call the team when a GW alert is received [Zoli et al. (2016)], and a completely new and flexible system (called **RTA-SCI**) for the management of scientific analyses. A sketch of the workflow is shown in Fig. 8. Also the *AGILEScience* App has been connected to this system. More details are presented in [Bulgarelli et al. (2019b)].

6 Conclusion

Working for the AGILE project has been a unique occasion to implement new hardware and software technologies, an experience that for several AGILE Team members lasted almost 20 years. The Ground Segment and the data pipelines played a fundamental role for the success of the Mission. A key element is the flexible software architecture in which the data flow and the Team workflow have been successfully integrated. During the time of AGILE operations in space we have reached a synergy between astrophysics and technology aimed at maximizing the scientific return of the Mission. This experience constitutes the basis for future involvement in new high-energy experiments and space projects.

Acknowledgements The AGILE Mission is funded by the Italian Space Agency (ASI) with scientific and programmatic participation by the Italian Institute of Astrophysics (INAF) and the Italian Institute of Nuclear Physics (INFN). Investigation supported by the ASI grant I/089/06/2. We thank the ASI management for unfailing support during AGILE operations. We acknowledge the effort of ASI and industry personnel in operating the ASI ground station in Malindi (Kenya), and the data processing done at the ASI/SSDC in Rome: the success of AGILE scientific operations depend on the effectiveness of the data flow from Kenya to SSDC and on the data analysis and software management.

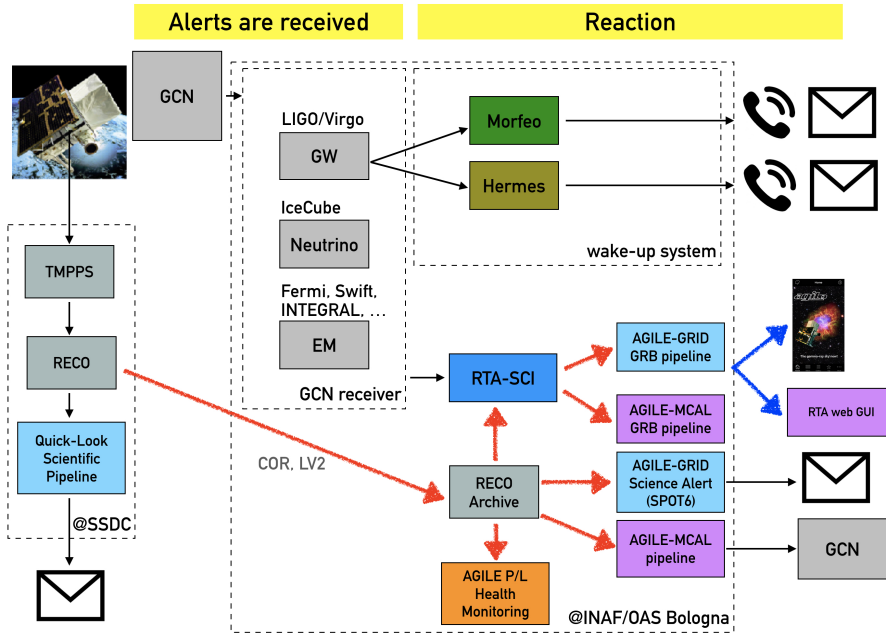

Fig. 8 The new AGILE Real-Time Analysis workflow at INAF/OAS Bologna, with the LV2 data received from SSDC. Alerts are received from the GCN network. Two independent wake-up systems call the AGILE Team if a new alert from LIGO/Virgo collaboration is received. If new alerts and/or data are received, the RTA-SCI performs the required scientific analysis. The GRID, MCAL and SA GRB Alert pipeline react to external science alerts. The AGILE-GRID Science Alert System (SPOT6) and the AGILE-MCAL pipelines process new data as soon as it is received from SSDC, that perform the reconstruction of the data. A web GUI and the *AGILEScience* App show the results of the automated processing. A backup of the AGILE RTA is also running in SSDC.

References

- [Branchesi et al. (2016)] Branchesi, M., (2016), Multi-messenger astronomy: gravitational waves, neutrinos, photons, and cosmic rays, *J. Phys.: Conf. Ser.* 718 022004
- [Bulgarelli et al. (2003)] Bulgarelli, A., Gianotti, F., and Trifoglio, M., (2003), PacketLib: A C++ Library for Scientific Satellite Telemetry Applications, ADASS XII, ASP Conference series 295, 473
- [Bulgarelli et al. (2008b)] Bulgarelli, A., Gianotti, F., et al. (2008), AGILE WebMon: Monitoring the AGILE payload through the WEB, *Proc. IEEE Nuclear Science Symposium Conference*, 2153-2158
- [Bulgarelli et al. (2012a)] Bulgarelli, A., Chen, A.W., et al. (2012), Evaluating the maximum likelihood method for detecting short-term variability of AGILE gamma-ray sources, *A&A*, 540, A79
- [Bulgarelli et al. 2014] Bulgarelli, A., et al. (2014), The Agile Alert System For Gamma-Ray Transients, *ApJ*, 781, 19
- [Bulgarelli et al. (2019)] Bulgarelli, A., Fioretti, V., Parmiggiani, N., et al. (2019), Second AGILE catalogue of gamma-ray sources, *A&A*, 627, A13-36
- [Bulgarelli et al. (2019b)] Bulgarelli, A., et al. (2019), The AGILE Gamma-Ray Observatory: software and pipelines, *Experimental Astronomy*, accepted

- [Chen et al. (2011)] Chen, A.W., Bulgarelli, A., et al., 2011, AGILE internal report, https://agile.ssdsc.asi.it/public/AGILE_SW_5.0_SourceCode/AGILE-IFC-OP-009_Build-21.pdf
- [Feroci et al. (2007)] Feroci, M., Costa, E., Soffitta, P., et al. (2007), SuperAGILE: the hard X-ray Imager for the AGILE space mission, NIM A, 581, 728
- [Gianotti et al. (2001)] Gianotti, F., Trifoglio, M., et al. (2001), DISCoS-Detector-Independent Software for On-Ground Testing and Calibration of Scientific Payloads Using the ESA Packet Telemetry and Telecommand Standards, ADASS X, ASP Conference series 238, 245
- [Giuliani et al. (2006)] Giuliani, A., Cocco, V., Mereghetti, S., et al. (2006), The AGILE on-board Kalman filter, NIM A, 568, 692
- [Marisaldi et al. (2008a)] M. Marisaldi et al., (2008), The Mini-Calorimeter on-board AGILE: 18 months in orbit, Proc. IEEE Nuclear Science Symposium Conference, 757-764
- [Marisaldi et al. (2008b)] M. Marisaldi et al., (2008), Gamma-ray burst detection with the AGILE mini-calorimeter, A&A, 490, 3, 1151-1156
- [Parmiggiani et al. (2015)] Parmiggiani, N., 2015, Master thesis
- [Pittori et al. 2009] Pittori, C., Verrecchia, F., Chen, A.W., et al. (2009), First AGILE catalog of high-confidence gamma-ray sources, A&A, 506, 1563
- [Pittori et al. 2013] Pittori, C., (2013), AGILE Data Center and AGILE science highlights , NuPhS, 239, 104
- [Tavani et al. 2009] Tavani, M., Barbiellini, G., Argan, A. et al. (2009), The AGILE Mission, A&A, 502, 995-1013
- [Trifoglio et al. (2000)] Trifoglio, M., Gianotti, F., Stephen, J. B., et al. (2000), Ground support equipment for scientific tests and calibration of the AGILE instrument, Proc. of SPIE, 4140, 478-485
- [Trifoglio et al. (2008)] Trifoglio, M., Bulgarelli, A., Gianotti, F., et al. (2008), Architecture and performances of the AGILE Telemetry Preprocessing System (TMPPS), Proc. of SPIE, 7011, 70113E
- [Trifoglio et al. (2013)] Trifoglio, M., Bulgarelli, A., Gianotti, F., et al. (2013), The AGILE Science Alert System, 7th AGILE Workshop, arXiv:1305.5389
- [Vercellone et al. (2007)] Vercellone, S., et al, (2007), AGILE gamma-ray detection of the Blazar 3C 454.3, The Astronomers's Telegram, 1170
- [Zoli et al. (2016)] , Zoli, A., Bulgarelli, A., et al., (2016), The AGILE Pipeline for Gravitational Waves Events Follow-up, ADASS XXVI, Trieste