



Publication Year	2007
Acceptance in OA	2024-01-31T11:06:41Z
Title	LVHX2/LFI mechanical interface verification
Authors	MORGANTE, GIANLUCA, DE ROSA, Adriano Giuseppe
Handle	http://hdl.handle.net/20.500.12386/34681
Volume	PL-LFI-PST-TN-092







TITLE: **LVHX2/LFI Mechanical Interface Verification**

DOC. TYPE: TECHNICAL NOTE

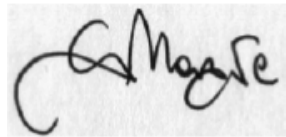
PROJECT REF.: PL-LFI-PST-TN-092 **PAGE:** 17

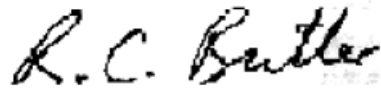
ISSUE/REV.: 2.0 **DATE:** 21.03.2007

Prepared by	G. MORGANTE SCS Op Manager LFI System Team	Date:	
	A. DE ROSA LFI System Team	Date:	
Agreed by	C. BUTLER LFI Program Manager	Date:	
Approved by	N. MANDOLESI LFI Principal Investigator	Date:	



DISTRIBUTION LIST

Recipient	Company/Institute	E-mail address
Chris Butler	INAF - IASF Bo	butler@iasfbo.inaf.it
Luca Stringhetti	INAF - IASF Bo	stringhetti@iasfbo.inaf.it
Maurizio Balasini	AAS – Italia, Milano	Maurizio.Balasini@aleniaspazio.it
Luca Pagan	AAS – Italia, Milano	Luca.Pagan@aleniaspazio.it
Paolo Leutenegger	AAS – Italia, Milano	Paolo.Leutenegger@aleniaspazio.it
J.P. Chambelland	AAS – Cannes	Jean-Philippe.Chambelland@alcatelaleniastospace.com
David Pearson	Jet Propulsion Lab	David.P.Pearson@jpl.nasa.gov



CHANGE RECORD

Issue	Date	Sheet	Description of Change
1.0	March 6 th 2007	All	First Issue of Document
2.0	March 21 st 2007	All	Preload loss section and general review

LIST of ACRONYMS

CTE	Coefficient of Thermal Expansion
CuBe	Copper – Beryllium Alloy
IF	Interface
JPL	Jet Propulsion Laboratory
LFI	Low Frequency Instrument
LVHX2	Liquid-Vapor Heat eXchanger 2
OFHC	Oxygen Free Copper
P	Pressure
SCS	Sorption Cooler Systems
SS	Stainless Steel
T	Temperature
TSA	Temperature Stabilization Assembly



TABLE OF CONTENTS

1	INTRODUCTION.....	5
2	APPLICABLE AND REFERENCED DOCUMENTS.....	5
2.1	APPLICABLE DOCUMENT	5
2.2	REFERENCED DOCUMENTS	5
3	INTERFACE MECHANICAL DESCRIPTION.....	6
3.1	PRESENT CONFIGURATION	6
3.1.1	<i>Screws</i>	6
3.1.2	<i>Spring Washers</i>	6
3.1.3	<i>Flat washer</i>	7
3.1.4	<i>Washer Plate</i>	8
3.2	INTERFACE MECHANICAL ANALYSIS	9
4	PRELOAD LOSS EVALUATION	10
4.1	8 SPRING WASHERS.....	13
4.2	SS / INCONEL WASHER.....	13
4.3	TITANIUM SCREWS	14
5	PRESSURE ON LVHX2 CU FLANGE	15
6	CONCLUSIONS.....	16



1 INTRODUCTION

The scope of this technical memo is to describe our analysis of the interface between the Sorption Cooler Cold End, LVHX2 + TSA stage, and the LFI main frame. This work is intended to be a general qualitative analysis of the IF providing a worst case analysis of the mechanical interface to justify or propose recommended configurations for flight. In the third Chapter a general description of the mechanical analysis of the interface is presented in order to provide the basic tools to understand the discussed issues.

Then, in Chapter 4, the mechanical behaviour of the interface at cryogenic temperatures is analysed: the expected thermal contraction and the related preload loss are evaluated to demonstrate compliancy to all mechanical and thermal requirements of such mission critical interface.

In Chapter 5 an evaluation of the pressure applied to the SCS flight LVHX2 in order to show its compliancy to the JPL requirements of max pressure applied ($P < 48$ MPa).

Chapter 6 presents a summary of the analysis and our preliminary conclusions.

2 APPLICABLE AND REFERENCED DOCUMENTS

2.1 APPLICABLE DOCUMENT

Ref.	Doc. Reference Nr	Issue/Rev	Document Title
AD-01	LFI_LVHX2 IF Signed	1/0	LFI to LVHX2 IF Signed Drawing
AD-02	000933106 DD03 01		AAS – Cannes CQM Test IF configuration drawing

TABLE 2-1: APPLICABLE DOCUMENTS

2.2 REFERENCED DOCUMENTS

Ref.	Doc. Reference Nr	Issue/Rev	Document Title

TABLE 2-2: REFERENCED DOCUMENTS



3 Interface Mechanical Description

Drawings of the interface are shown in Fig.1a and b.

This first drawing shows a sketch of the interface: materials, components specifications and top level dimensions are summarized in Fig.1a. Figure 1b shows a cut view of the interface 3D model indicating actual detailed dimensions.

Total height of TSA stage is reported as 20.64 mm, but adding all components thickness (the two Stainless Steel resistances and the Copper plate) this total results correct only including the two 0.04 mm gaps (see Fig1b) included in the JPL drawing. The presence of these two gaps is probably needed to take into account the thickness of gold plating. This discrepancy is less than a mm and it does not have any impact on thermal contraction estimation.

For the purpose of the analysis, copper components have been considered made of Oxygen Free Copper (OFHC) while for the stainless steel thermal resistances and washer plate SS 316L was used.

3.1 Present Configuration

A pictorial view of present IF setup is shown in Fig.2 (combination of 2 spring washers, 1 single flat washer on the washer plate) and Fig.3 (whole “sandwich”).

3.1.1 Screws

According to this configuration, the screws used are:

A2 – 70 DIN 912 M4 L40 SS304L, thread diameter $D_s = 4.0$ mm and a total length $L = 40$ mm entering the threaded hole in the LFI main frame by about 6 mm, this leaving an “effective length” of the screw equal to $L_{eff} \approx 34$ mm. By “effective length” of screw it is meant the length from head to first thread, i.e. the one involved in the mechanical load, at least at first order.

3.1.2 Spring Washers

Beneath each screw head there are two Cu-Be Belleville washers totally flattened by the torque applied (see Fig.2). The Belleville washers are Schnorr CuBe2 with the following specs:

Material is CuBe2, $D_e = 8$ mm, $D_i = 4.2$ mm, thickness = 0.4 mm, max deflection = 0.2 mm (see Fig.4). Single washer max preload (the load under 100% deflection) in elastic range ~ 176 N for a total of ~350 N.

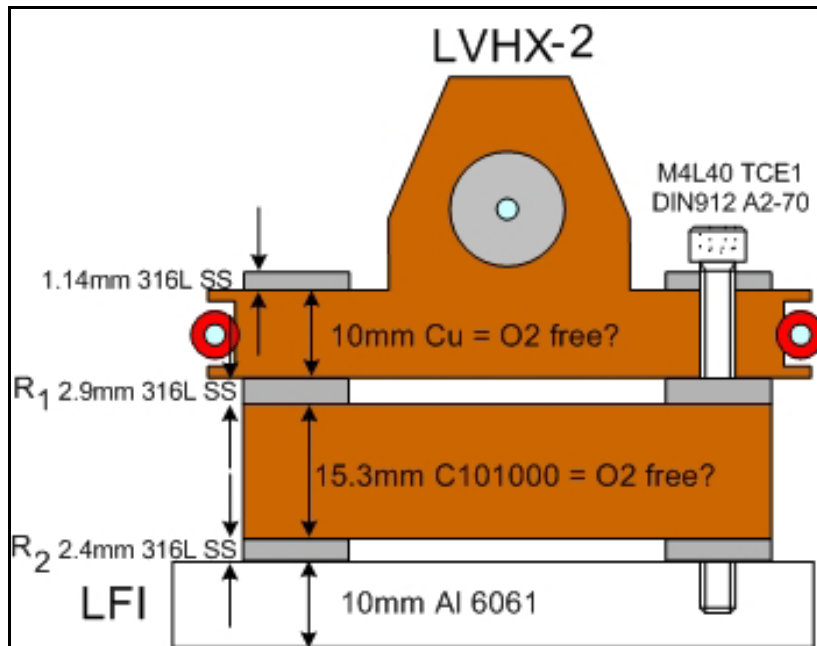
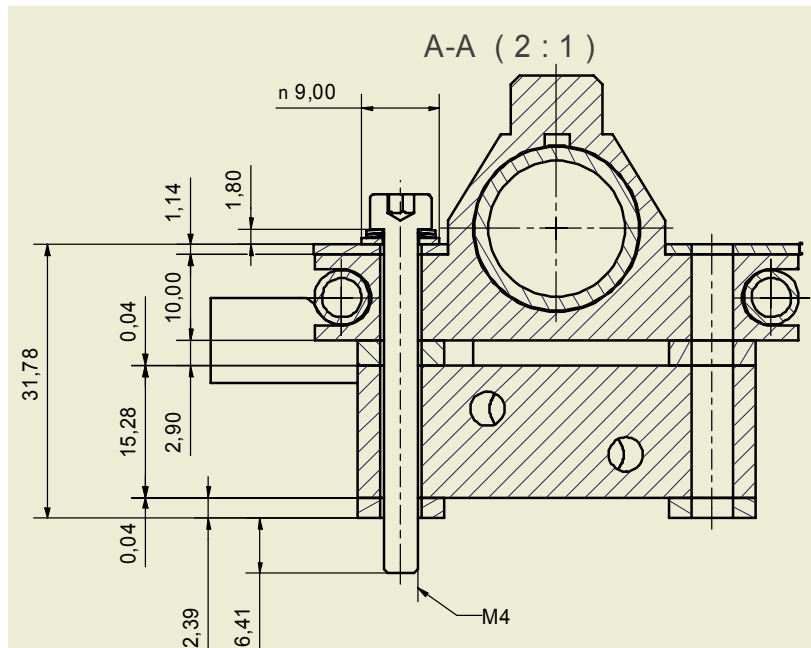

Fig.1a (above); 1b (below)



3.1.3 Flat washer

Below the 2 spring washers there is a single flat washer, M4 A2 70 DIN 125 A made of 304L SS ($D_o = 9\text{mm}$) with $D_i = 4.3\text{ mm}$, $D_o = 9.0\text{ mm}$, thickness= 0.8 mm.



3.1.4 Washer Plate

The LVHX2 copper flange is protected by a washer plate (see Fig.2 and 3) made of 316L SS, 60 mm long, 15 mm wide and 1.14 mm thick.

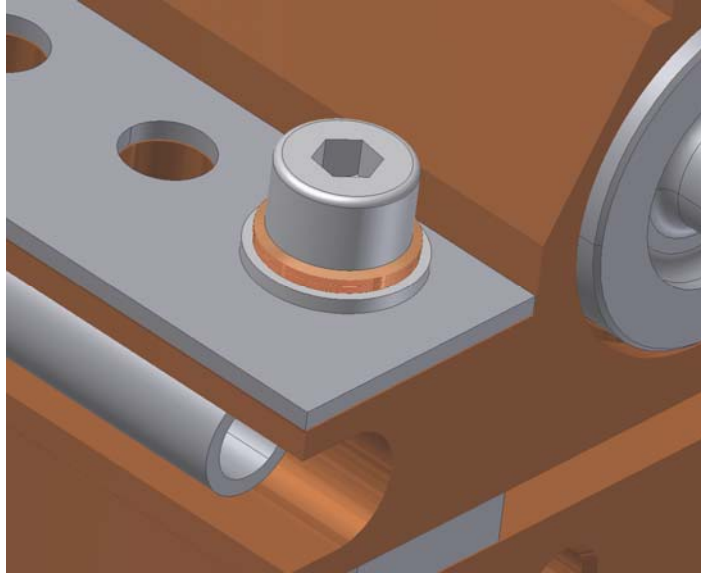

Fig. 2

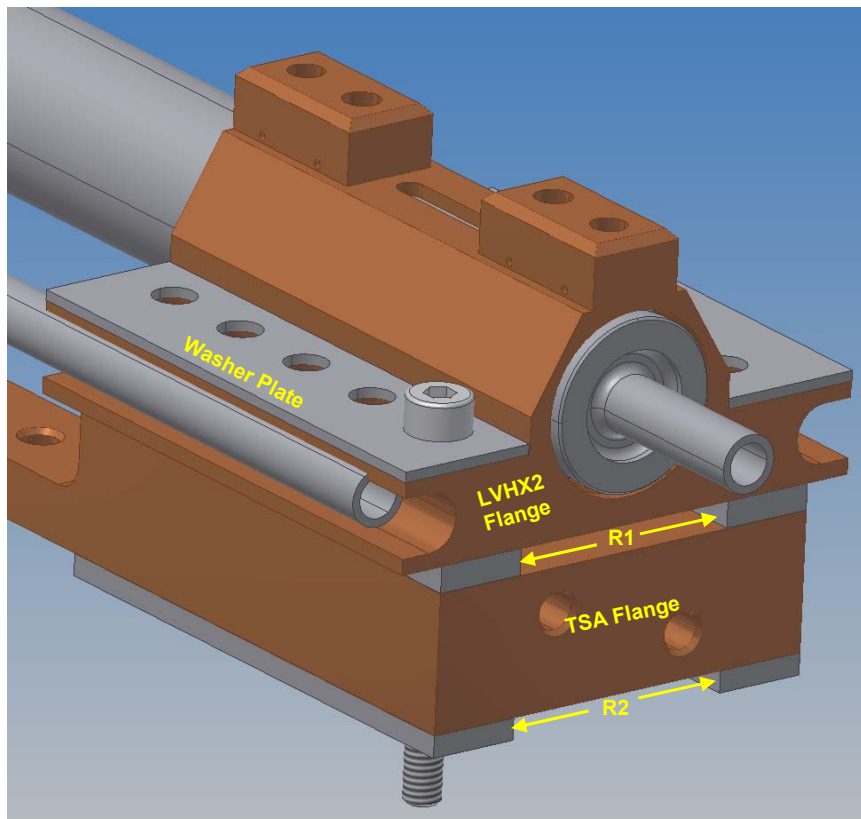

Fig. 3



3.2 Interface Mechanical Analysis

If the spring washers are flattened by the torque the thickness is only 0.4 mm. They can recover a maximum of 0.20 mm deflection (see Fig.4)

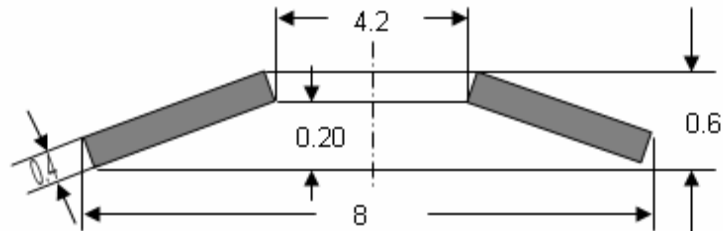

Fig. 4

The general simple formula to relate torque T and preload P is:

$$P = \frac{1000 \times T}{f \times D_s} \quad \text{or} \quad T = \frac{f \times D_s \times P}{1000} \quad \text{Eq. 1}$$

where the torque is in Nxm, D_s is the screw thread diameter in mm and f the friction coefficient that is:

- ⇒ 0.1 in case of good lube
- ⇒ 0.2 if contact is medium dry
- ⇒ 0.3 if very dry

Taking into consideration the present setup, the presence of the SS helicoil, the lacking of specific lubrication and the coupling between a hard (SS) and soft metal (Cu), a reliable estimation of the friction coefficient value could be ~0.2.

The minimum yield stress σ_y of A2-70 SS M4 screws is about 450 N/mm², with an effective area $A_{\text{eff}} = 7.75 \text{ mm}^2$ (values reported in manufacturer specs). The max preload that can be applied to the screw is:

$$P_{\text{max}} = \sigma_y \times A_{\text{eff}} = 3487.5 \text{ N}$$

Taking, as a margin of safety, 75% of the maximum, the preload to be applied to the screw is then about 2620 N that in our set up, using Eq.1, translates into a torque of 2.1 N x m.

At this point, given the torque and using Eq. (1), it is possible to build a table of actual preload as a function of the friction coefficient:

Friction Coeff.	Torque (Nm)	Preload (N)
0.175	2.1	3000
0.2	2.1	2625
0.3	2.1	1750

Table 1

In the present setup, with no lubricant, at max we have a preload lower than 3000 N (around 2625 N).



4 Preload Loss Evaluation

This analysis has been carried out on the hypothesis of the Elastic Theory validity, including the Small Displacement Model and the Superposition Theory.

In Table 2 the elastic modulus and the integrated thermal contraction coefficient (CTE) between 300 and 20 K of the used materials are summarized.

Material	E [MPa]		CTE 300-20K
	300K	20K	
SS 316L	193270	207360	2.97E-03
SS 304	197510	209320	2.97E-03
Cu OHFC	118000	130000	3.26E-03
Cu Be 2	135000	140000	3.24E-03
Al 6061	70000	90000	4.14E-03
Ti-6Al-4V	114000	140000	1.74E-03

Table 2

The **stiffness** of the screw can be calculated by:

$$K_T = \frac{E_T \times S_S}{L_{\text{eff}}} \text{ [N/mm]} \quad \text{Eq. 2}$$

where E_T is the elastic modulus at temperature T (see Table 2), S_S is the screw section (now the *geometrical* one, not the effective one) and L_{eff} is the effective length of screw that holds the load (basically from screw head to first thread, i.e. the one holding the force).

From Eq.2 we get $K_{300} \approx 72300$ N/mm at 300K and $K_{20} \approx 76400$ N/mm at 20K

Knowing the stiffness is now possible to calculate the **displacement** of the screw due to the applied preload:

$$\Delta L_{\text{Screw}} = \frac{\text{Preload}}{\text{Stiffness}_{300\text{K}}} \approx 0.037 \text{ mm} \quad \text{Eq. 3}$$

The thermal contraction factor of materials is indicated by the CTE

$$\alpha = \frac{1}{L} \left(\frac{\partial L}{\partial T} \right)$$

that, integrating between 300 K and 20 K, gives the dimensionless values reported in Table 2 (units are $(L_{300} - L_{20}) / L_{300}$ [m/m]).

These values have been found in different literature sources (Van Sciver, White, Barron), websites (NIST) and dedicated software (CMP, Cryocomp). They all give very similar values, at least at first order, and it is practically impossible to notice differences within the different alloys of SS or the different types of copper so that it is safe to use the reported numbers.

At cryogenic temperature, the screw (304 SS) shrinks toward the thread (i.e. toward the Al main frame, see Fig.1), the three SS components (R1, R2 and the washer plate) shrink by



the same amount. The copper stages (LVHX2 base plate and TSA control) shrink by the same factor among them. The Al mainframe is not taken into account because the screw contracts respect to the first thread so only the first mm of Al is considered in this analysis.

The **absolute** thermal contraction of the IF at cryo temperature can be calculated for each layer of the “sandwich” by the materials CTE reported in Table 2.

Fig.5 Ref.	Description	Material	Thickness [mm]	Contraction [mm]
1	Spring washers (2)	CuBe2	0.4 x 2 = 0.8	0.0026
2	Single flat washer	304L SS	0.8	0.0024
3	Washer Plate	316L SS	1.14	0.0034
4	LVHX2 flange	OHFCu	10.00	0.0326
5	Thermal Resistance R1	316L SS	2.90	0.0086
6	TSA stage	OHFCu	15.30	0.0499
7	Thermal Resistance R2	316L SS	2.40	0.0071
8	LFI MF 1 st thread depth	Al 6061	1.0	0.0041
	Total		h_{TOT} = 34.34	Δh_{abs} = 0.1107

Table 3

where h_{TOT} is the total height of the sandwich (equal to what was indicated with the screw effective length) and Δh_{abs} is simply the total contraction. The number of each layer is reported, for clarification, in Fig. 5.

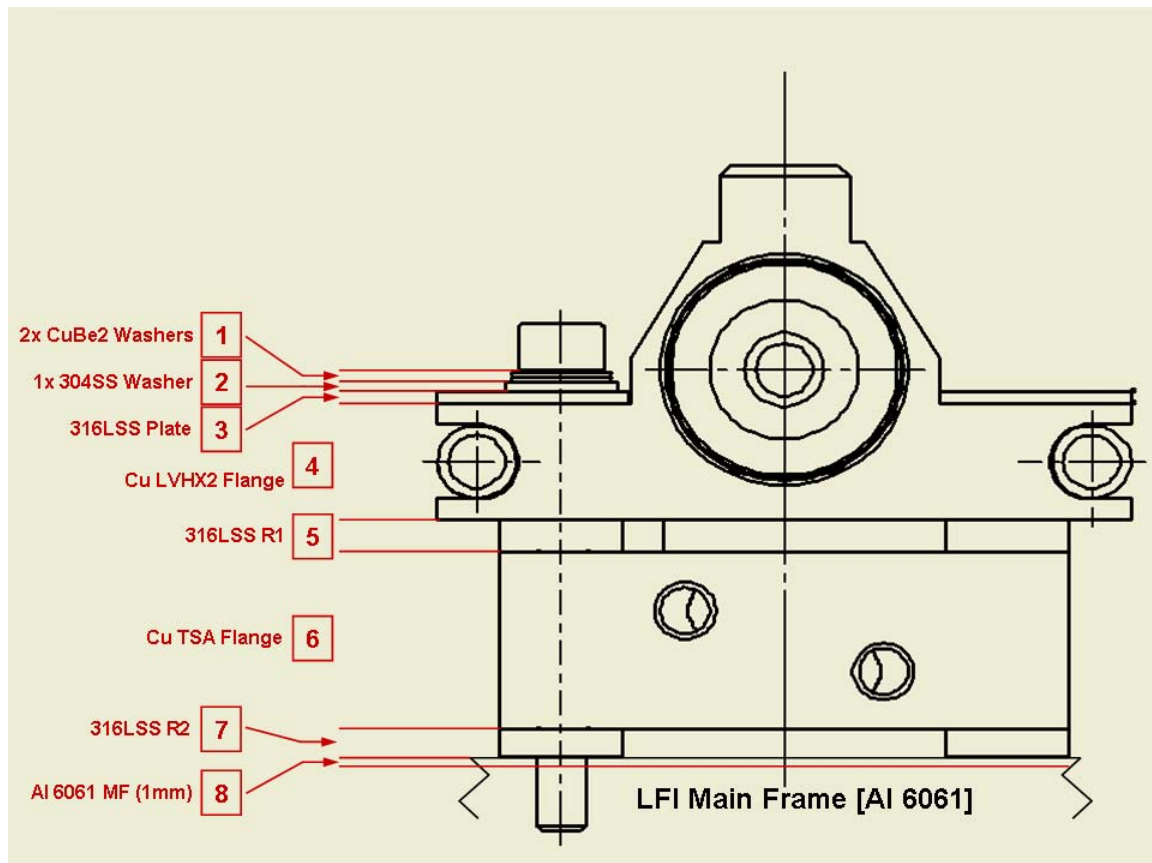

Fig. 5



At first order, since the SS layers all contract by the same amount, so as the Cu layers do, the relative displacement is simply given by the difference between the SS - Cu and SS - Al linear contraction coefficients multiplied by the thickness of Cu/Al:

$$\Delta S_{SS-Cu} = (0.00326 - 0.00297) \times 26 \text{ mm} \approx 0.0075 \text{ mm}$$

and

$$\Delta S_{SS-Al} = (0.00414 - 0.00297) \times 1 \text{ mm} \approx 0.0012 \text{ mm}$$

Adding these values, the total contraction results $\approx 0.0087 \text{ mm}$.

An equivalent estimation can be obtained by subtracting the screw relative displacement from the total contraction:

$$\Delta h_{\text{diff}} = \Delta h_{\text{abs}} - h_{\text{TOT}} \times \text{CTE}_{300-20K}^{\text{SS}} \cong 0.0087 \text{ mm} \quad \text{Eq. 4}$$

where h_{TOT} is basically equal to the screw L_{eff} . The total differential contraction is $\sim 9 \mu\text{m}$.

This differential contraction is the main responsible for the preload loss at cryogenic temperature.

The screw behaves like a spring under a force so we can compare the total contraction of the IF with the screw displacement due to the applied preload. The result is that the screw displacement is 4 times the sandwich total loosening due to thermal contraction:

$$\frac{\Delta L_{\text{screw}}}{\Delta h_{\text{TOT}}} \approx 4.3 \quad \text{Eq. 5}$$

so that the screw itself could fully recover the differential displacement. Moreover the spring washers, on their side, can recover up to 0.2 mm of deflection, so this very small thermal contraction can be easily retrieved even if a loss of preload is inevitable.

In order to evaluate this loss, the screw stiffness at 20K can be used. In fact, the preload is basically given by the stiffness multiplied by the displacement that, in cryo conditions, is due to the relative contraction of the screw – TSA system:

$$P_{20K} = K_{20K} \times (\Delta L_{\text{screw}} - \Delta h_{\text{diff}}) \cong 2110 \text{ N} \quad \text{Eq. 6}$$

with a net loss of the order of $\sim 500 \text{ N}$.

This loss does not seem enough to appreciatively degrade heat transfer capabilities (basically the thermal conductance) of the IF, but it is very important that this degradation be evaluated and quantified.



4.1 8 Spring Washers

If we add 6 more spring washers to the present setup and repeat the same analysis, it can be shown that no appreciable advantage can be obtained. In this analysis we neglect the preload loss due, for a given torque, to the relative friction and misalignment) between washers. As a matter of fact, spring washers manufacturers do not advice to use more than 3 or 4 in series.

The presence of 8 Belleville washers increases the screw L_{eff} (36.74 mm) and consequently reduces the screw stiffness by less than 7%:

$$K_{300K} = \frac{E_{300K} \times S_s}{L_{eff}} \approx 68000 \text{ [N/mm]} \quad \text{and} \quad K_{20K} = \frac{E_{20K} \times S_s}{L_{eff}} \approx 71400 \text{ [N/mm]}$$

At the same time the screw displacement changes by the same amount ($\Delta L_{eff} = 0.039$ mm). The spring washers contribution to absolute thermal contraction changes by a very small factor (see Table 3): from 0.0026 mm to 0.0104 mm. In the end we have a differential contraction between screw and interface sandwich equal to 0.0094 mm (practically the same).

If all these results are inserted in Eq. 6 the preload at cryo temperature increases by few N's

$$P_{20K} = K_{20K} \times (\Delta L_{screw} - \Delta h_{diff}) \cong K_{20K} \times (0.039 - 0.0094) \cong 2113 \text{ N}$$

showing no practical advantage in multiplying the number of spring washers since they work out of their elastic regime. This result is essentially due to the fact that in all these conditions the CuBe washers are totally flattened and stressed by a preload much higher than the max one this combination of washers can provide at max deflection. For this reason they don't work in their elastic range so that their stiffness is greatly increased by these conditions: we could basically say that they almost work as flat washers. The very small thermal contraction at cryo T ($\sim 9 \mu\text{m}$) is not enough to relax their stress and take them back into their elastic range, so the expected preload loss in the present setup conditions is limited to about 20%.

4.2 SS / Inconel Washer

In order to maintain the preload at cryo temperatures, higher stiffness Belleville washers should be used after a careful selection of their elastic properties. Substituting the two CuBe2 with one or two austenitic SS or Inconel washers with the required stiffness, it would be possible to have a resulting spring preload comparable with the one applied by the screw and, for this reason, able to work in the elastic regime. In this case, using a spring washer (or set of washers) with a stiffness that, under used preload, yields a deflection much bigger than the absolute relaxation due to thermal contraction, it would be possible to maintain the preload even in cold conditions.

A detailed dedicated analysis should be carried out in order to accurately select the needed properties and the total number of such spring washers. It is very likely that to get this result, higher thickness washers should be used so that spring washers suitable for such set up should be custom made. Moreover several tests should be planned to check the validity of the analysis and correlate it with data.



4.3 Titanium Screws

Let us consider now the case of using Ti screws instead of the proposed A2 M4 SS ones, as it was done for the CQM testing at CSL. Following the same path of the previous calculation, substituting 304SS properties with Ti-6Al-4V (usual screw Ti alloy, see Table 2), quite different results, as expected, are obtained. Ti contracts less than SS (almost a factor of 2) with temperature, so the differential contraction is much bigger, of the order of one quarter of the spring washers max deflection:

$$\Delta h_{\text{diff}} = \Delta h_{\text{abs}} - h_{\text{TOT}} \times \text{CTE}_{300-20\text{K}}^{\text{Ti}} \cong 0.051 \text{ mm}$$

The screw **stiffness** can be calculated from Eq.2 with the Ti values reported in Table 2: we get $K_{300} \approx 42000 \text{ N/mm}$ at 300K and $K_{20} \approx 52000 \text{ N/mm}$ at 20K.

The torque applied at 300 K for CQM test was 2.2 Nxm, with a resulting preload of ~2750 N. Using Eq. 3 is now possible to calculate the **displacement** of the screw due to the applied preload:

$$\Delta L_{\text{Screw}}^{\text{Ti}} = \frac{\text{Preload}}{\text{Stiffness}_{300\text{K}}} \approx 0.066 \text{ mm}$$

that is almost a factor of 2 bigger than the SS screw.
To calculate the preload at 20 K we can use again Eq.6

$$P_{20\text{K}} = K_{20\text{K}} \times (\Delta L_{\text{screw}} - \Delta h_{\text{diff}}) \cong 800 \text{ N}$$

a much lower final preload at 20K. If we consider the preload at 300K the net loss is close to 2000 N, much bigger than the present set up case. In fact, the differential thermal contraction is now much bigger, close to the screw displacement and, as mentioned, of the order of 1/4 of the spring washers max deflection. The relaxation of the two Belleville washers is probably the main responsible for the loss of preload. Using 8 CuBe2 washers with the Ti screw, for the same reasons summarized in previous paragraph,



5 Pressure on LVHX2 Cu flange

The cold end LVHX's are made of soft copper so standard torques will yield the flange: for this reason JPL require that preload is limited to a max pressure of 48 MPa directly applied onto the copper.

For what concerns the pressure evaluation on the copper flange of LVHX2 we decided to use a preload of 3000 N (see Table 1) as a worst case (upper limit) for our analysis. At first we considered the average contact pressure between the single SS washer (the one below the Belleville's) and the SS washer plate. So we need to evaluate the ratio between the screw preload and the contact surface of the SS washer. If we consider a worst case of 3000N load directly applied on the surface of the washer (9mm OD, annular, ID is 4.2mm) we get a pressure applied of:

$$P = 3000 \text{ N} / 50 \text{ mm}^2 = 60 \text{ MPa}$$

Now, these 60 MPa are actually applied onto the SS washer plate that distributes the force on a wider area. If we apply the "Rotscher cone (45 degree)" theory, we could consider at first order the load all applied on a surface wider in diameter by twice the plate thickness (1.14mm) amount only. In this case we get the force distributed on a slightly wider annular surface of 11 mm OD. This gives a pressure of

$$P = 3000 \text{ N} / 80 \text{ mm}^2 = 37.5 \text{ MPa}$$

applied on the Cu that is well below the required limit of 48MPa even with a 3000N worst case preload.



6 Conclusions

The analysed cases are summarized in the next Table:

	Screw Material	Nr of CuBe2 Washers	Screw L_{eff} [mm]	Screw ΔL_{eff} [mm]	Total contraction [mm]	Differential contraction [mm]	Stiffness at 20K [N/mm]	Preload at 20K [N]	Loss wrt 300K [N]
1	304L SS	2	34.34	0.036	0.111	0.0087	76400	2086	539
2	304L SS	4	35.14	0.037	0.113	0.0089	74600	2096	529
3	304L SS	8	36.74	0.039	0.118	0.0094	71400	2113	512
4	Ti-6Al-4V	2	34.34	0.066	0.111	0.0511	51000	760	1990
5	Ti-6Al-4V	8	36.74	0.071	0.118	0.0547	48000	782	1968

Notes:

- All numbers (last three columns especially) are to be considered indicative values, uncertainty on material properties has an impact on results even if not to the point of changing the qualitative results of this analysis
- For 304L SS M4 screws torque is 2.1 Nxm, for a room T preload ~2625 N
- For Ti screws M4 torque applied in CQM test was 2.2 Nxm, for a room T preload ~2750 N
- Cases with SS screws show spring washers working out of elastic range (high stiffness at both room and cryo conditions)
- Cases with Ti screws show spring washers that, at cryo T, can work in the elastic range (spring relaxation, lower stiffness, higher preload loss)

In conclusion, the following points provide a summary of the analysis results:

1. Even with a max preload of 3000 N, the pressure “transferred” to the soft copper of the LVHX2 flange is well within JPL, requirement, so that for this ranges of load it does not seem to be an issue.
2. The present IF mechanical setup seems to be compliant to the requirements in terms of preload loss due to thermal contraction at cryo temperatures.
3. This preload loss cannot imply a dramatic change in the IF thermal conductance, so no major problems are expected on this issue but direct evaluation and quantification of the conductance **must** be made in next step of this analysis.
4. Usage of Ti screws does not seem recommendable.
5. Usage of carefully selected more rigid Belleville washers (austenitic SS or Inconel) would be helpful to prevent any preload loss in cryo conditions. Nevertheless, suitable spring washers need likely to be custom machined.



6. Usage of more CuBe2 washers (4, 6, 8) does not seem to improve much the thermo-mechanical behaviour of the IF. The presence of 8 could, in principle, help in some amount because they might provide a stiffer system also because of their relative interaction. 8 (or more) spring washers require longer A2-70 screws (M4L42 or 45) that need to be procured (off the shelf product). In case the change of screw length is not a viable option an intermediate solution (with 4 or 6) could be arranged.
7. As already mentioned in point 3, the heat transfer capacity of the IF needs to be evaluated. This will be the subject of the next issue of this analysis. In order to keep open the possibility of using more than two Belleville washers, in case the next analysis results will suggest this implementation, it would be advisable to quickly procure longer M4 SS A2-70 screws (off the shelf, length = 42 or 45 mm or both).