



Publication Year	2018
Acceptance in OA	2020-11-05T16:57:52Z
Title	The polishing of WEAVE spectrograph collimator mirror
Authors	Izazaga, Rafael, Carrasco, Esperanza, Hidalgo, Andrea, Dalton, Gavin, Trager, Scott, Lopez Aguerri, J. Alfonso, BONIFACIO, PIERCARLO, VALLENARI, Antonella, Abrams, Don Carlos, Middleton, Kevin
Publisher's version (DOI)	10.1117/12.2314342
Handle	http://hdl.handle.net/20.500.12386/28176
Serie	PROCEEDINGS OF SPIE
Volume	10706

PROCEEDINGS OF SPIE

[SPIDigitalLibrary.org/conference-proceedings-of-spie](https://spiedigitallibrary.org/conference-proceedings-of-spie)

The polishing of WEAVE spectrograph collimator mirror

Izazaga, Rafael, Carrasco, Esperanza, Hidalgo, Andrea, Dalton, Gavin, Trager, Scott, et al.

Rafael Izazaga, Esperanza Carrasco, Andrea Hidalgo, Gavin Dalton, Scott Trager, J. Alfonso L. Aguerri, Piercarlo Bonifacio, Antonella Vallenari, Don Carlos Abrams, Kevin Middleton, "The polishing of WEAVE spectrograph collimator mirror," Proc. SPIE 10706, Advances in Optical and Mechanical Technologies for Telescopes and Instrumentation III, 107060J (10 July 2018); doi: 10.1117/12.2314342

SPIE.

Event: SPIE Astronomical Telescopes + Instrumentation, 2018, Austin, Texas, United States

The polishing of WEAVE spectrograph collimator mirror

Rafael Izazaga^{1,*}, Esperanza Carrasco¹, Andrea Hidalgo^{1,2}, Gavin Dalton^{2,3}, Scott Trager⁴, J. Alfonso L. Aguerri⁵, Piercarlo Bonifacio⁶, Antonella Vallenari⁷, Don Carlos Abrams⁸ and Kevin Middleton³

¹Instituto Nacional de Astrofísica, Óptica y Electrónica, Luis Enrique Erro # 1, Tonantzintla, 72840 Puebla, Mexico. ²Department of Physics, University of Oxford, Keble Road, Oxford, OX1 3RH, UK.

³RAL Space, STFC Rutherford Appleton Laboratory, Harwell Oxford, OX11 0QX, UK.

⁴Kapteyn Institut, Rijksuniversiteit Groningen, Postbus 800, NL-9700 AV Groningen, Netherlands.

⁵Instituto de Astrofísica de Canarias, C/Vía Láctea, s/n, E38205 La Laguna, Tenerife, Spain.

⁶GEPI Observatoire de Paris, Place Jules Janssen, 92195 Meudon, France.

⁷INAF, Astronomical Observatory of Padova, Vicolo dell'Osservatorio, 5, 35141 Padova PD, Italy.

⁸Isaac Newton Group of Telescopes, Calle Alvarez de Abreu, 70, E-38700 Santa Cruz de La Palma, Canary Islands, Spain

* izazagax@gmail.com

ABSTRACT

WEAVE is the new wide field multi-object and integral field survey facility for the prime focus of the 4.2 m William Herschel Telescope. It is located at the Observatorio Roque de los Muchachos, in La Palma, Canary Islands, Spain. WEAVE fiber-fed spectrograph offers two resolutions, $R \sim 5000$ and $20,000$. It has a collimator mirror and two cameras optimized for the wavelength intervals of 366 - 959 nm and 579 - 959 nm, respectively. One of the responsibilities of INAOE within the WEAVE collaboration is the polishing of the collimator mirror, made of OHARA CLEARCERAM®-Z HS. The collimator has a diameter of 660 mm, a central thickness of 44.7 mm and a weight of 56.8 kg. The main specifications are: 2 fringes irregularity in a clear aperture of 624 mm diameter and a radius of curvature of 1224.65 mm ± 0.15 . In this work, we present the polishing process and final results for the collimator. In particular, we describe the tools developed for its manufacturing, the modifications carried out to the conventional polishing machine to support the glass. Additionally, the interferometric optical irregularity measurements are presented. The collimator polishing process is finished fulfilling all the optical specifications.

Keywords: optical fabrication and testing, polishing, multi-object spectroscopy

1. INTRODUCTION

WEAVE is the new multi-object spectrograph for the prime focus of the 4.2-m William Herschel Telescope (WHT) at the Observatorio del Roque de los Muchachos, on La Palma in the Canary Islands [1]. WEAVE stands for WHT Enhanced Area Velocity Explorer. The acronym aptly reflects the challenge of positioning correctly, in a 2-dimensional plane, a large number of fibers [2]. It will allow observers to record spectra of up to 1,000 stars and galaxies in a single exposure. This huge leap in observing efficiency will allow astronomers to tackle several astrophysical problems that until now have remained out of reach [3].

The WEAVE spectrograph unit is a dual-beam and dual-resolution system with an interchangeable fiber slit input. The beam from the fibers illuminates a spherical collimator mirror that produces a 190 mm diameter beam. A dichroic beam splitter, located after the collimator mirror, divides the beam into a blue arm and red arm. The beam in each arm passes through a set of collimator corrector lenses and is dispersed by a volume phase holographic (VPH) grating [4]. Each arm of the spectrograph can operate in a low- or high-resolution mode, the change being accomplished by

substitution of the grating, rotation of the camera and adjustment of cryostat tilt angle and focus position. In the blue arm there are two high-resolution wavebands (Figure 1).

WEAVE is now in the construction phase, a detailed description of the status is given by Dalton, et al. in this proceeding [5]. INAOE is responsible of the manufacturing of the WEAVE spherical red and blue camera lenses and the polishing of the collimator mirror. Within the WEAVE collaboration, NOVA/ASTRON is the institution responsible of the spectrograph work-package. Therefore, INAOE has been working directly with this team. In this work, we present the polishing process for the collimator mirror, the tools developed for its manufacturing and the modifications carried out to the conventional polishing machine to support the glass and to perform the polishing process. In addition, the interferometric optical set-ups used to measure the collimator irregularity are presented.

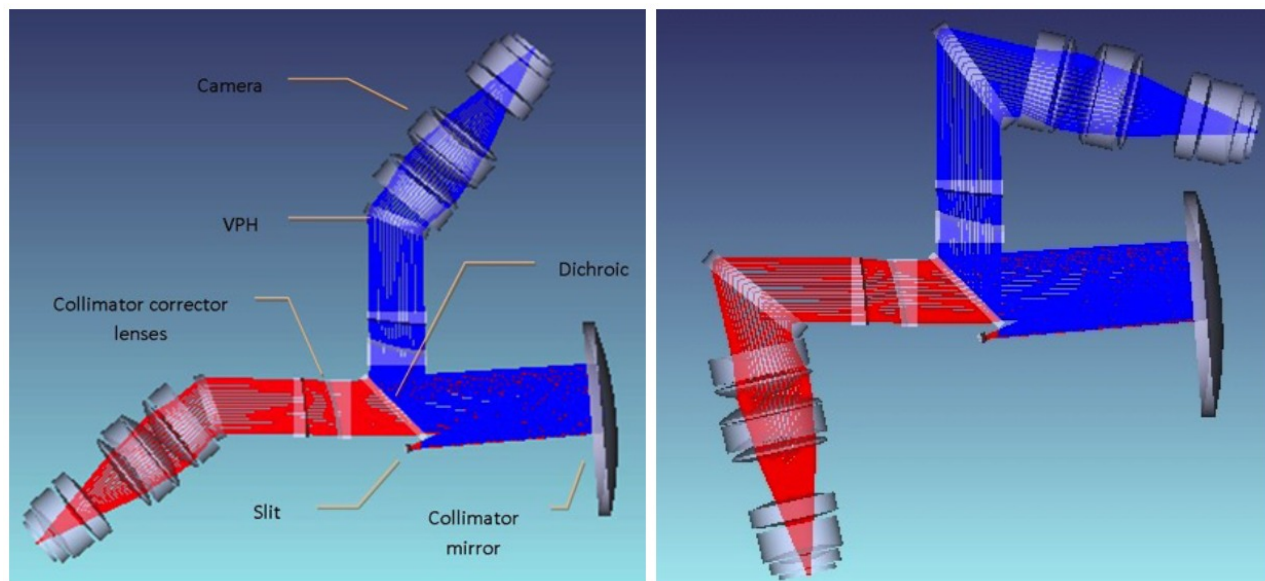

Figure 1. WEAVE optical layout: low (left) and high (right) resolution modes.

2. COLLIMATOR MIRROR SPECIFICATIONS

A section of the manufacturing drawing is shown in Figure 2. The diameter is 660 ± 1 mm with a border thickness of 90 ± 0.5 mm and a central thickness of 44.7 mm. Its reference mass is 56.814 kg. The selected material is OHARA CLEARCERAM® Z HS with $n_d = 1.5466$. The Radius of Curvature (RoC) is 1224.65 ± 0.15 mm CC sphere and a 624 mm diameter clear aperture. The back surface is flat with pronounced bevels as shown in Figure 2. The coating specification considers a minimum coated area diameter of 646 mm, a 7 mm bevel with a protective chamfer on the edges of 1-2 mm at 45° as detailed in the drawing. A permissible tilt angle of 2 arcmin equivalent to 0.384 mm is specified. Regarding optical quality the specification are: surface irregularity 2 fringes at 633 nm and surface imperfection tolerances of 40/20 (MIL-PRF-13830B), both in the clear aperture. INAOE received the collimator with the RoC already generated to 1224.21 mm.

Additional parameters were controlled during manufacturing that directly influences the strategy for grinding and polishing. The recorded information and controlled parameters not included in the final report are:

1. blank revision: integrity, blank diameter, border thickness, material, manufacturer ID, photo, weight, flatness, parallelism, RoC, surface irregularity, border angles and bubbles (see Figure 3).
2. surface manufacturing: flat tool parallelism and flatness, grinding and polishing tool characteristics.
3. cleaning: surface imperfections map, comments about stains and its removal.

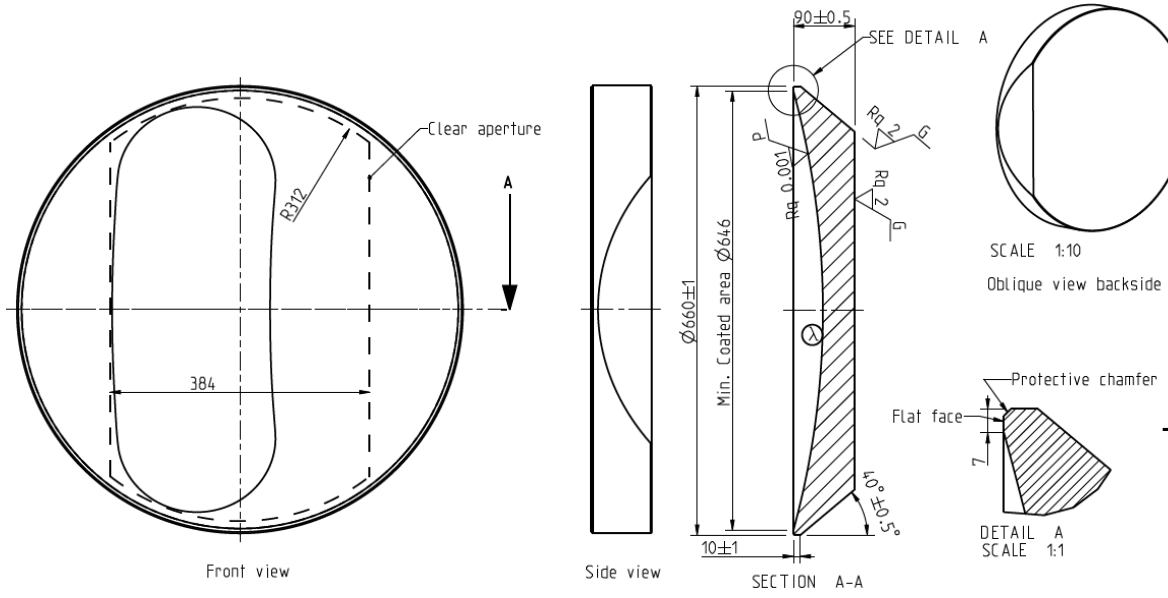

Figure 2. A section of the WEAVE collimator mirror manufacturing drawing.



Figure 3. (a) Collimator blank verification. (b) RoC initial measurements.

3. THE MANUFACTURING PROCESS

Before starting the polishing process, a finite element analysis (FEA) in static mode was carried out to know the tensions and displacements of the collimator mirror. In Figure 4a we show the mesh defined for the finite element model: the mesh takes into account the 900 mm baseplate of the machine, an additional 660 mm aluminum plate to hold the blank during polishing and the mirror blank itself. The simulations took into account gravity and weight of the polishing tool considered as a static weight placed at several points in the mirror surface. Considering only the effect of gravity the maximum displacement in X direction (vertical) was 0.032 microns, see Figure 4b. The simple effect of gravity gives a considerable deformation at the edge of the mirror. The analysis was of particular importance due to the singular form of the mirror that includes two lateral bevels for mounting purposes as shown in Figure 5. Considering the lateral bevels and the central thickness of 44.7 mm for a 660 mm diameter, the main challenge that our team faced was to remove the astigmatism aberration during the final polishing steps.

3.1 Blocking

The collimator mirror was placed over an aluminium plate that match the specified diameter of 660 mm (Figure 6a). The polishing machine is a Strasbaugh model 6CR2-DC-1 with a modified baseplate of 900 mm diameter. It consists in a rotating axis holding the mirror and an overarm that holds the grinding/polishing tool. To reduce the effect of astigmatism aberration during the polishing process two wedges made of Nylamid® M were placed in the lateral bevels of the mirror (Figure 6b). The blocking of the mirror was carried out using wax and tape (Figure 6c). With these steps the mirror was ready for grinding and polishing process.

3.2 Grinding

In the machine a rotating axis holds the mirror and an oscillating arm holds a glass tool maintaining loose abrasive between both surfaces. Aluminum oxide was used in the grinding process (Microgrit® WCA, from Universal Photonics Inc.). We used stages of 40, 25, 15 and 5 microns as average particle size (APS). In the middle of the process a visual inspection was carried out to verify the smoothness of every stage. Figure 7a is a detail of the grinding glass tool, Figure 7b is the grinding process in the polishing machine. The grinding process took about a month.

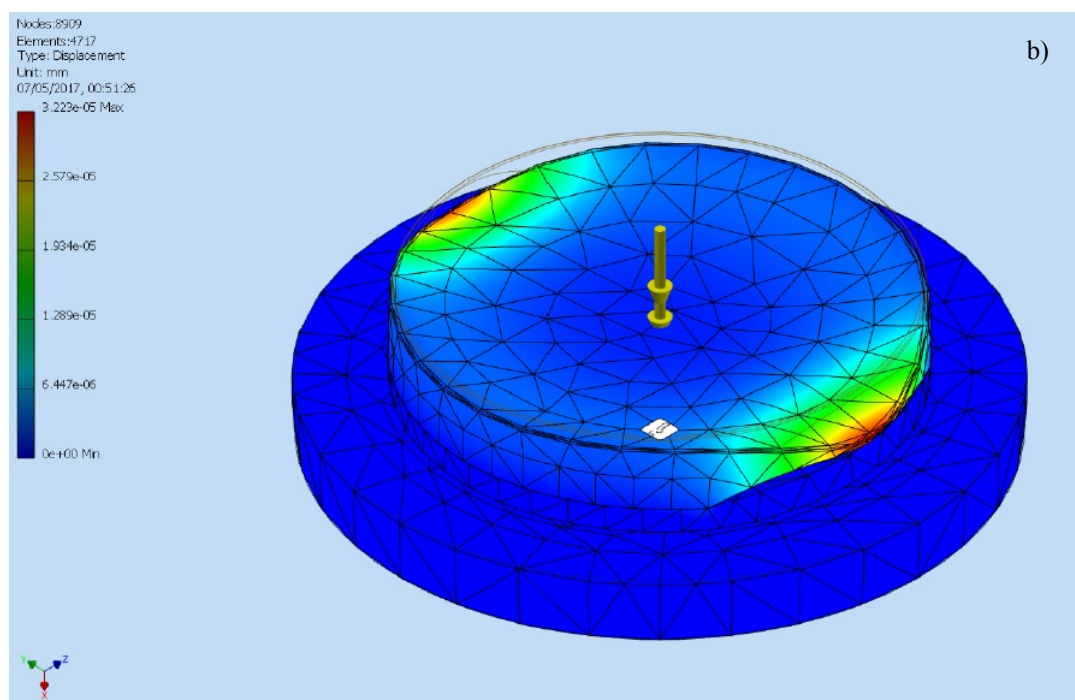
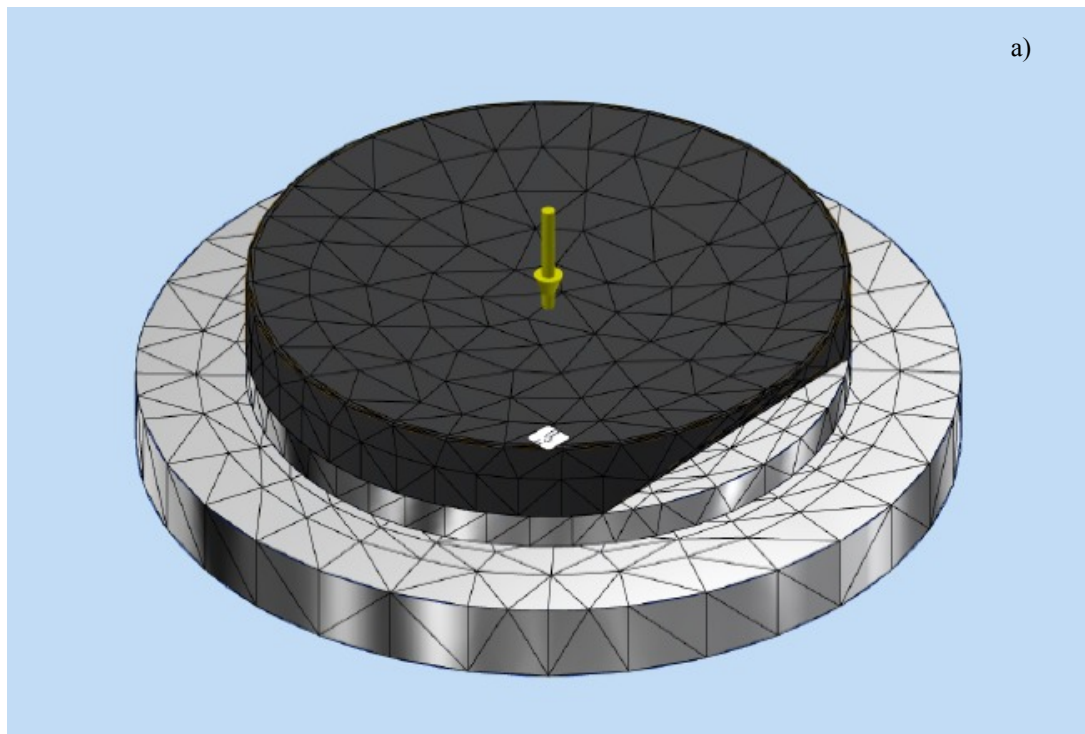

Figure 4. a) 3D model. Mesh considering two baseplates and the blank. The blank diameter is shown as a black contour. b) Graph showing the displacements in X direction (vertical) where the maximum values are 0.032 microns at the bevels.

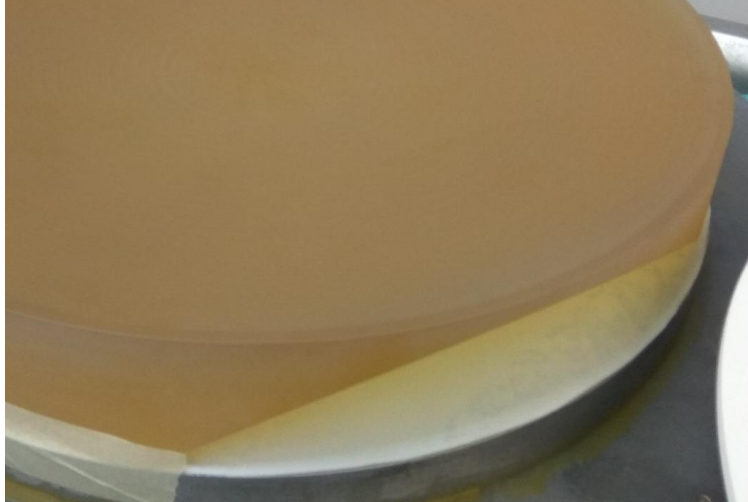

Figure 5. Section of the blank. One of the lateral bevels can be appreciated on the right side of the image.

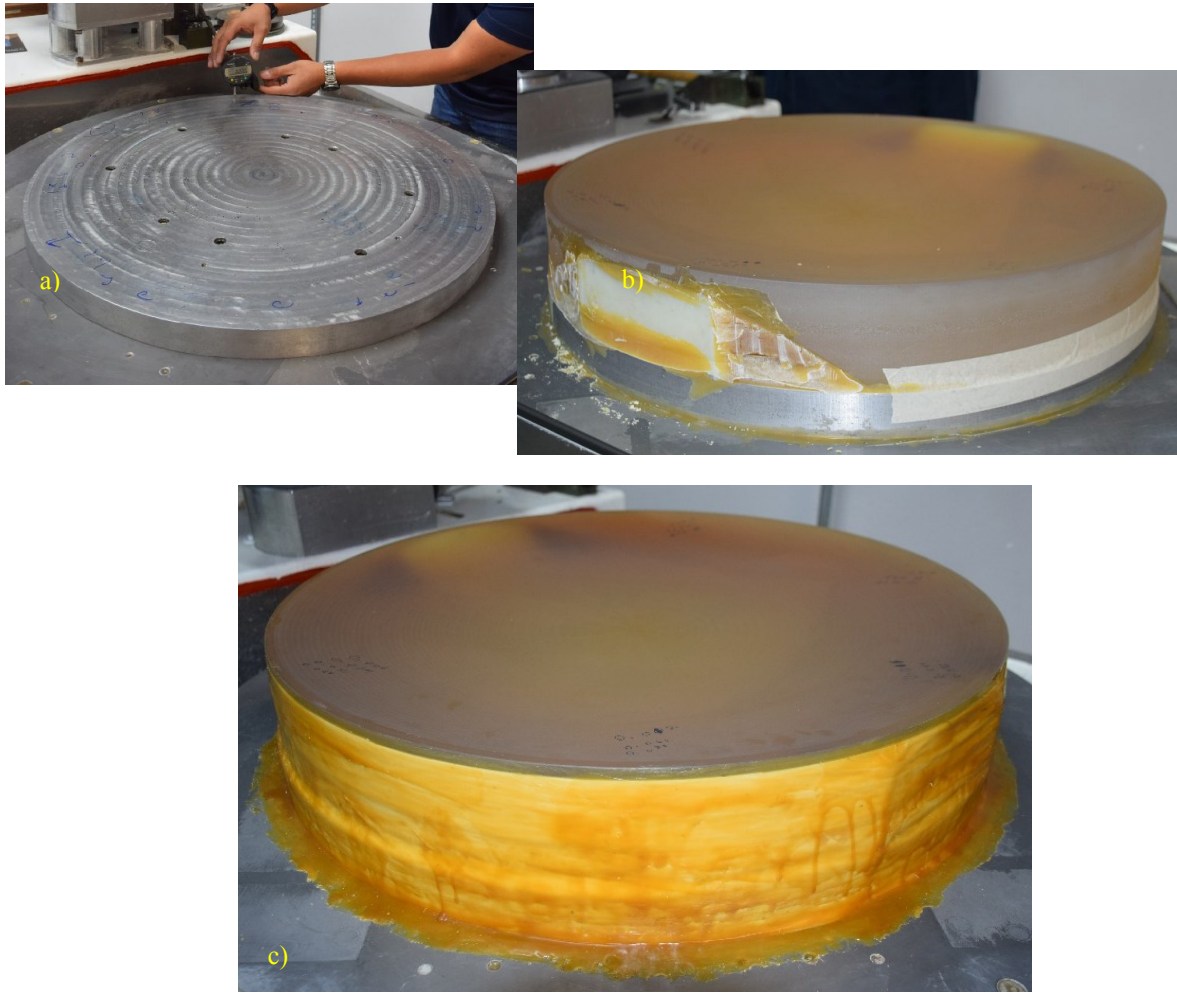

Figure 6. Steps for blocking the 660 mm diameter collimator blank.

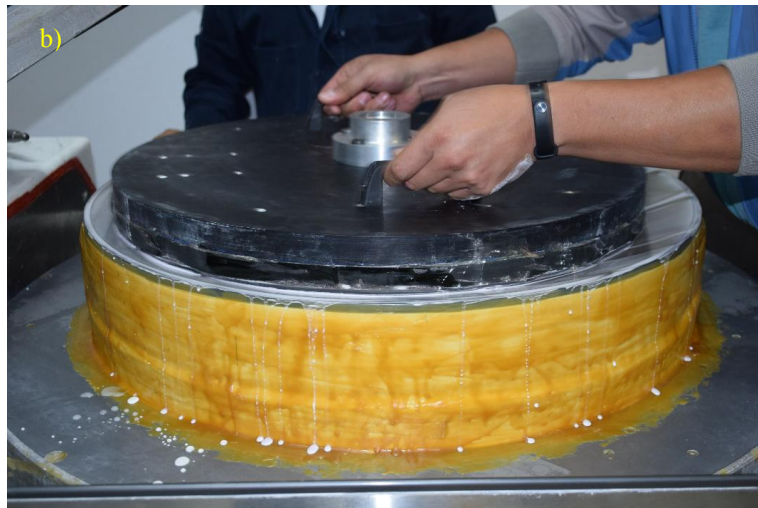
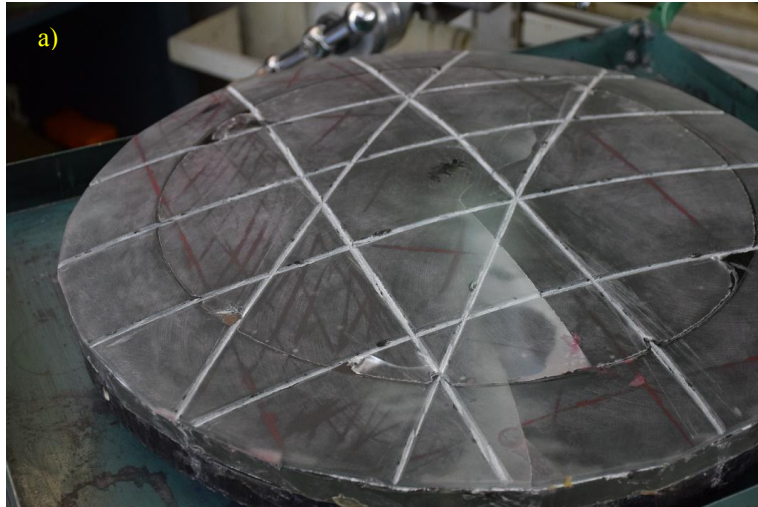

Figure 7. (a) Detail of the grinding glass tool of 560 mm diameter. (b) Grinding process.

3.3 Polishing

The polishing process was carried out in the same Strasbaugh® machine, using a pitch polishing tool, see Figure 8a (pitch #450, Universal Photonics Inc.). The polishing compound selected was Zirox K (Zirconium oxide) 1.4 microns APS. In the final stage of the polishing process (Figure 8b) a final polishing round was carried out using Hastilite ZD (Cerium/Zirconium blend) 0.9 microns APS to improve the smoothness of the surface. All polishing compounds are from Universal Photonics Inc.



Figure 8. (a) Detail of the polishing pitch tool, 600 mm diameter. (b) Polishing process.

3.4 Irregularity measurements

The irregularity measurements were carried out using a Zygo® Fizeau type interferometer. We accomplish a full aperture interferometry test, using a modified set-up, by including a high-quality flat as a fold mirror between the collimator mirror and the reference sphere in the interferometer, as it illustrated in Figure 9. This set-up allows to test the complete used aperture of the collimator.

The whole system was placed on an iron structure with the interferometer in a horizontal position (Figure 10a), the fold mirror at 45° (Figure 10b) and the collimator mounted in the polishing machine. The fold mirror is a high-quality reference flat (Edmund Optics® 304.8 mm diameter with irregularity $PV = \lambda/20$). The interferometer reference sphere used to measure irregularity was also of very high quality with the following characteristics: Zygo Corp. $f/0.65$, 101.6 mm diameter with irregularity $PV = \lambda/20$. The interferograms obtained with the set-up described were analyzed using Durango® interferometry software (Diffraction International Inc.).

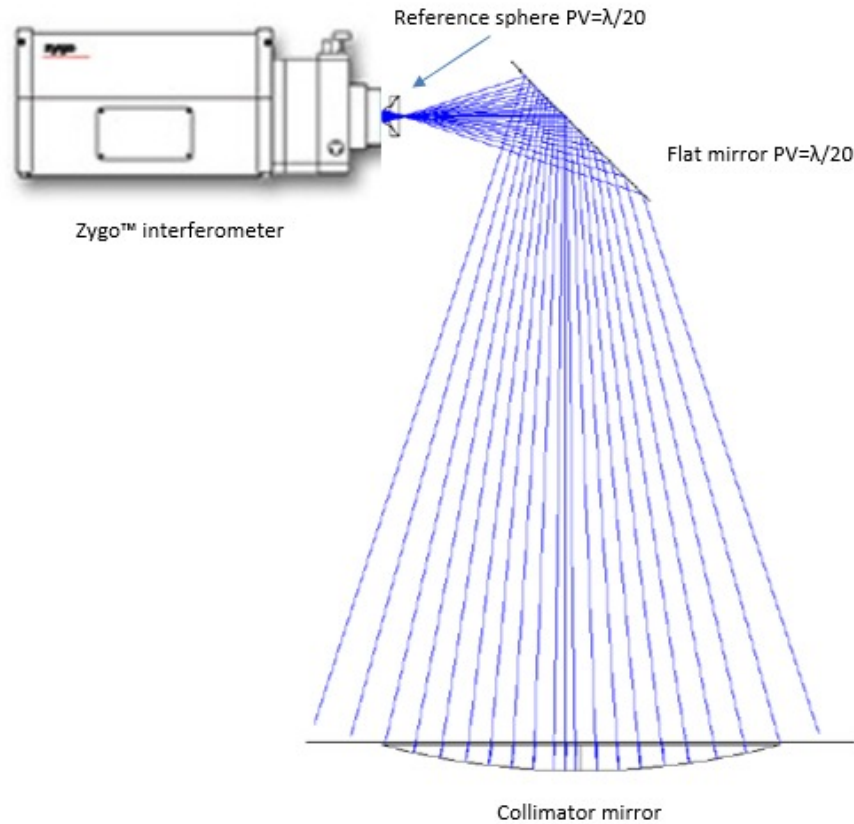

Figure 9. Experimental set-up to measure the collimator irregularity.

4. DATA ACQUISITION

4.1 Polishing rounds

During the polishing process the following three parameters were monitored:

1. Irregularity. To comply the PV irregularity specification of 2 fringes in a 660 mm diameter.
2. RoC. 1224.65 +/- 0.15 mm, the tolerance was 0.01% of the RoC, a very important issue.
3. Scratch and Dig (S/D). 40/20 in a 660 mm diameter.

The three parameters were controlled simultaneously. The main challenge in the polishing process was to reduce the astigmatism aberration (increasing the irregularity PV value) as the smoothness was accomplished in a relative small period of time of 18 hours, while the astigmatism remained giving us an irregularity PV value of up to 9 fringes in some polishing rounds. We continued -for several months- the polishing process by varying the mirror axis and overarm speeds until comply all specifications. Here we present the results of the last polishing runs.

4.1 Measurements

To avoid thermal effects that could alter the irregularity measurements the protocol was the following: once a polishing round was finished, the mirror was left laying down for 16 hours before an interferometric test was carried out. This measurement was the initial reference value for the next round.

In Table 1 we present the values of the polishing parameters of the last six final polishing rounds. The values out of specification are shown in pink while in green those that comply.

Table 1. Polishing parameters and specifications of the last six polishing rounds.

Round	Axis speed (rpm)	Overarm speed (rpm)	P-V Irregularity (fr)	RoC (mm)	S/D
1	20	9	5.123	1225.30	60/60
2	18	9	4.419	1225.45	60/40
3	18	7	3.816	1224.93	40/20
4	16	7	2.635	1224.87	40/20
5	16	5	1.747	1224.65	20/20
6	16	3	1.492	1224.62	20/10

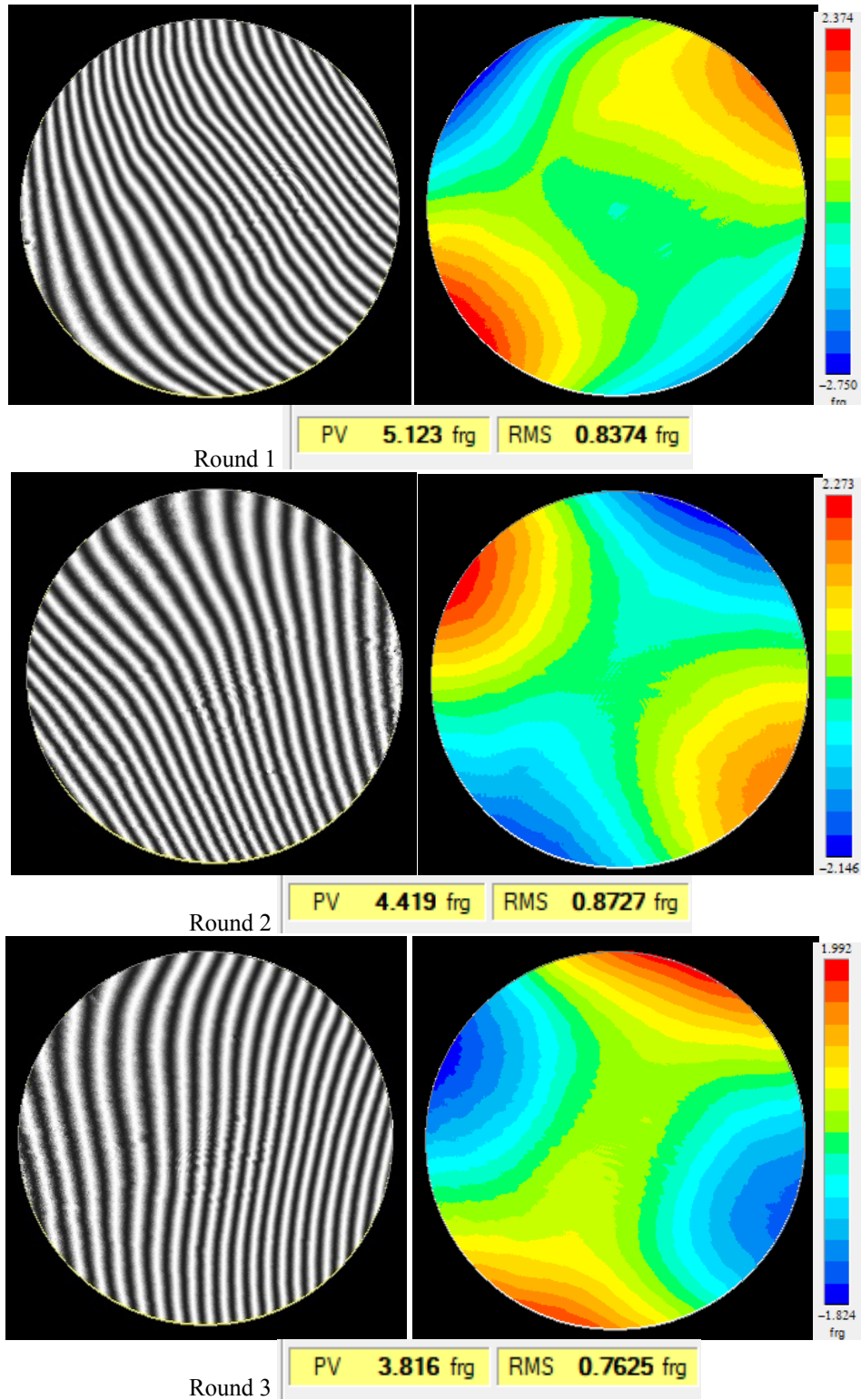
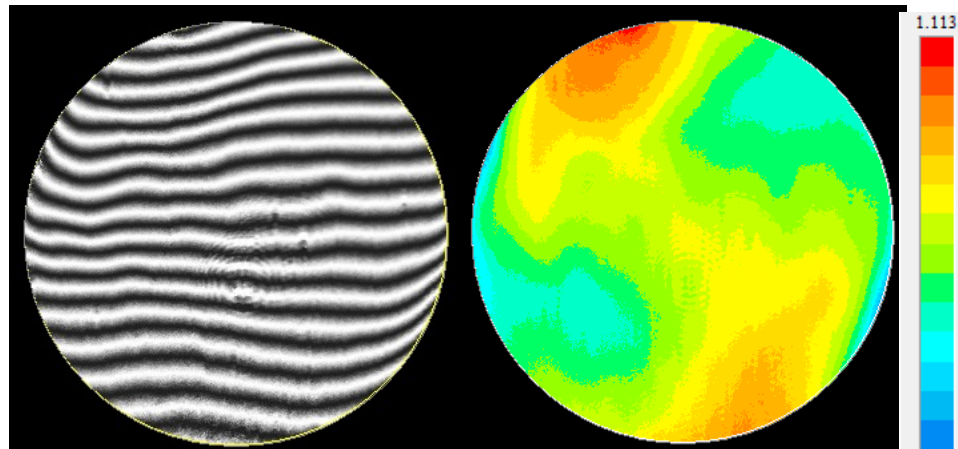
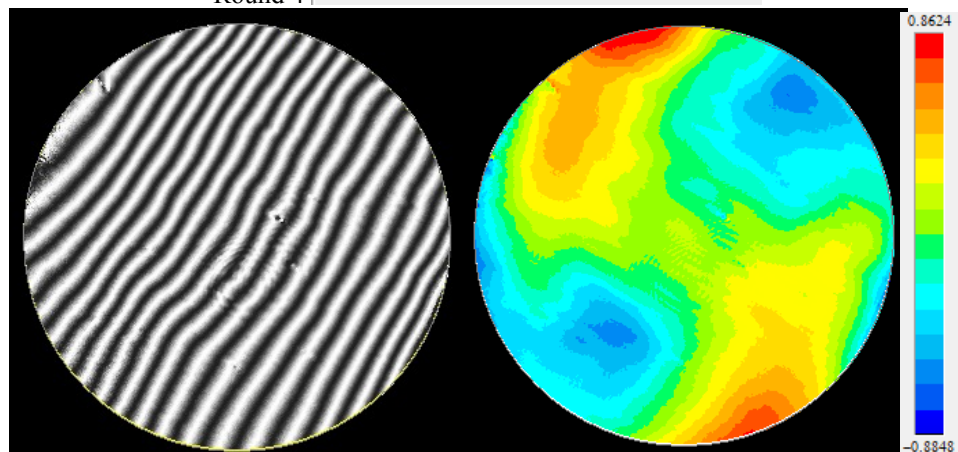

Figure 10. Polishing rounds 1, 2 and 3. Left: interferograms. Right: phase maps.



Round 4 PV 2.635 frg RMS 0.3149 frg



Round 5 PV 1.747 frg RMS 0.3109 frg

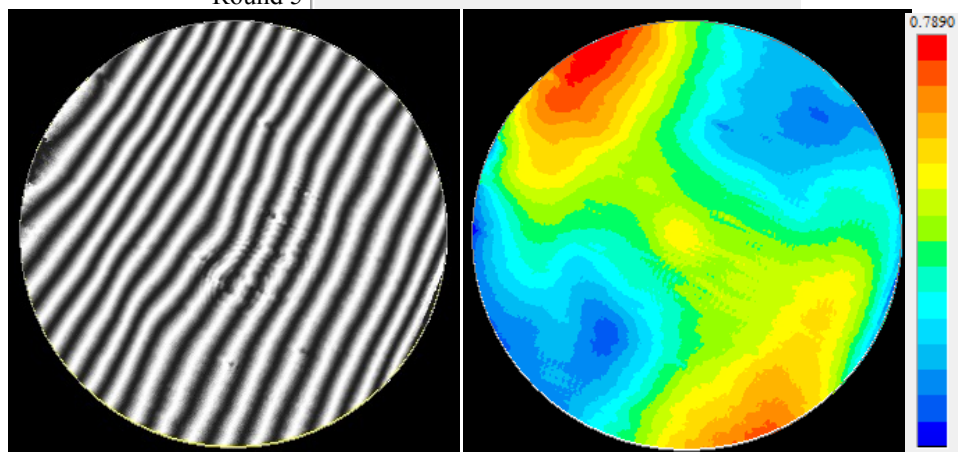

Round 6 PV 1.492 frg RMS 0.3056 frg

Figure 11. Polishing rounds 4, 5 and 6. Left: interferograms. Right: phase maps.

4. RESULTS

In Table 2 a summary of collimator manufacturing results is presented. The first and second columns correspond to each parameter and its specified value. In the third column, we report the values measured and in the fourth the instrument and/or method used for the measurement. Figures 12 and 13 show the collimator polished during the cleaning and packing processes.

Table 2. Specifications and final measurements of the collimator.

Collimator mirror manufacturing summary			
NOVA Reference	03069		
Part Name	Collimator mirror		
Glass	OHARA Clearceram®-Z HS		
Parameter	Specification	Measurement	Instrument or method
RoC (mm)	1224.656 +/- 0.15	1224.625	Trioptics Sphercompact +/- 0.001mm (diameter=152.4mm)
Irregularity in clear aperture (frg)	2	1.492	Zygo® interferometer / Full aperture
S/D MIL 13830B	40/20	20/10	Visual inspection vs. calibrated reference (Brysen optical 7641896)
Protective chamfer (mm)	1-2 x 45°	1.2	Mitutoyo Caliper +/-0.01 mm
Roughness (nm)	1	0.69	Witness sample/ Wyco® NT1100 profiler
Edge diameter (mm)	660+/-1	660	Craftman® Sidewinder Measuring tape
Central thickness (mm)	N/A	47.26	Calculated by means of Sagitta value
Border thickness (mm)	90+/-0.5	90.65	Mitutoyo® Caliper +/-0.01 mm
Wedge (arcmin)	2	0.130	Mitutoyo® Dial Indicator +/-0.01 mm

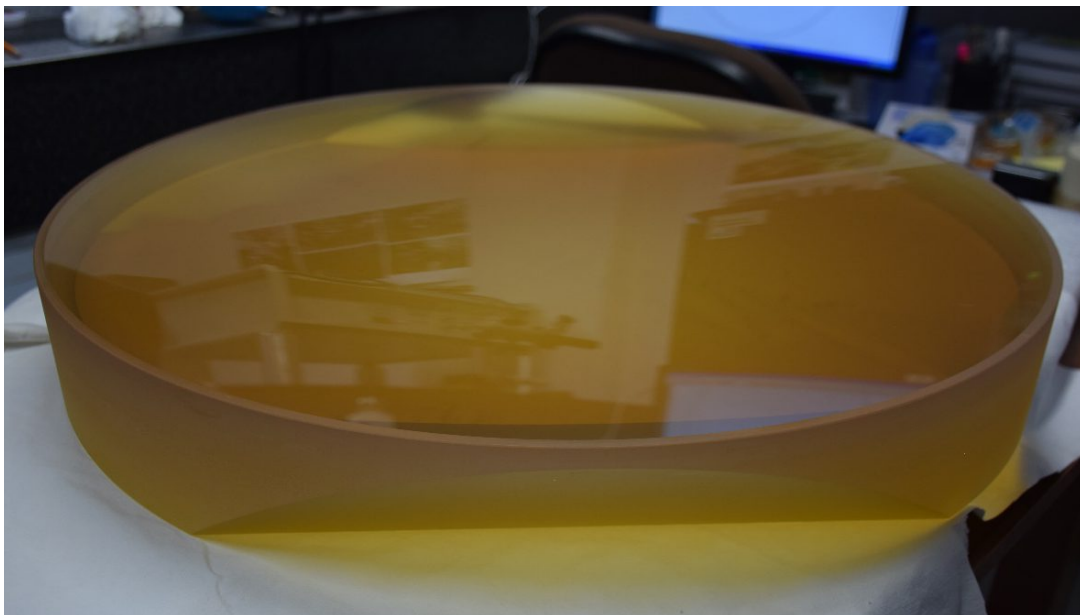

Figure 12. Collimator cleaning process prior to the S/D evaluation.



Figure 13. Collimator packing process.

5.- CONCLUSIONS

The manufacturing process of the WEAVE collimator mirror was an enormous challenge for our optical shop due to the large diameter of the mirror, the high demanding specifications and the design characteristics, in particular the geometry of the bevels and the central thickness. FEA simulations were carried out to ensure the manufacturability within acceptable time and risks. The manufacturing processes were described showing the modifications to the polishing machine and the optical test set-up. The results show that the collimator fulfills the requirements. The collimator is ready for coating.

ACKNOWLEDGEMENT

We want to thank José Miguel Arroyo, Valentín López, Magdalena Hernandez, Javier Arriaga, Jose Armando de la Luz, Gloria Jaimes, Jorge Reyes, Araceli Huepa, Alfonso Salas and Eladio Rueda, personnel of the INAOE Optical Workshop, for its valuable work and effort during polishing, mounting and cleaning processes.

REFERENCES

- [1] Gavin Dalton, et al. "Weave: the next generation wide-field spectroscopy facility for the William Herschel telescope". Proc. SPIE **8446**, pp. 84460P–84460P, (2012).
- [2] Kevin Rogers, et al., "The design of the WEAVE spectrograph," Proc. SPIE **9147**, pp. 91476H, (2014).
- [3] Gavin Dalton, et al., "Project overview and update on WEAVE: the next generation wide-field spectroscopy facility for the William Herschel Telescope," Proc. SPIE **9147**, pp. 91470L (2014).
- [4] Gavin Dalton, et al., "Final design and progress of WEAVE: the next generation wide-field spectroscopy facility for the William Herschel Telescope," Proc. SPIE **9908**, pp. 99081G (2016).
- [5] Dalton, G. et al. "Construction progress of WEAVE: the next generation wide-field spectroscopy facility for the William Herschel Telescope". Proc. SPIE **10702**, pp. 10702-47 (2018).