



## Rapporti Tecnici INAF INAF Technical Reports

<b>Number</b>	290
<b>Publication Year</b>	2024
<b>Acceptance in OA@INAF</b>	2024-02-26T12:01:16Z
<b>Title</b>	Finite Element Analysis of SRT's L-P band receiver support
<b>Authors</b>	ATTOLI, Alessandro, Riccardo, Simoni, MARONGIU, Pasqualino, RODA, JURI
<b>Affiliation of first author</b>	O.A. Cagliari
<b>Handle</b>	<a href="http://hdl.handle.net/20.500.12386/34819">http://hdl.handle.net/20.500.12386/34819</a> , <a href="https://doi.org/10.20371/INAF/TechRep/290">https://doi.org/10.20371/INAF/TechRep/290</a>

# Finite Element Analysis of SRT's L-P Band Receiver Frame

Alessandro Attoli<sup>1</sup>, Riccardo Simoni<sup>2</sup>, Pasqualino Marongiu<sup>1</sup>, and Juri Roda<sup>3</sup>

<sup>1</sup>INAF–OAC Osservatorio Astronomico di Cagliari, Selargius, Italy

<sup>2</sup>DIMCM, Dipartimento di Ingegneria Meccanica, Chimica e dei Materiali, Università degli Studi di Cagliari, Cagliari, Italy

<sup>3</sup>INAF – Istituto di Radio Astronomia di Bologna, Bologna, Italy

## ABSTRACT

As well as scientific research is continuously evolving, the Sardinia Radio Telescope also follows the trend of technological progress. New receivers have been installed on the facility, and more may be installed in the near future, in order to offer a wide-range and always state-of-the-art service. This report proposes a structural strength analysis of a frame which supports one of the Sardinia Radio Telescope's receivers, the L-P band receiver, performed by the Finite Element Method. The obtained results have made possible to evaluate the use of the same frame design for other receivers. In addition, an alternative solution has been investigated to assess any room for improvement for the current support.

Keywords: Finite Element Method, Structural analysis, Mechanical design

## 1 INTRODUCTION

The Sardinia Radio Telescope (SRT) is an international high-profile scientific facility for radio astronomy, geodynamics and space applications [1][2]. The versatility of the instrument facilitates to keep pace with technological advancement. In this regard, a PON (National Operational Program) funding assigned to INAF by the Ministry of University and Research allowed to meet requests from the scientific community expanding the observational capabilities of the radio-astronomical instrument [3]. In particular, a performance upgrade has made it possible to increase the previous SRT operating frequency range of 0.3 to 26.5 GHz [4], up to the highest performance achievable by the antenna design, i.e. 116 GHz and 2.5-mm wavelength [5].

The SRT optical system consists of a 64-meter diameter primary mirror, a secondary reflector, and three other mirrors located in the Beam Wave Guide (BWG) room (see Figure 1). This ensures four distinct focal positions.

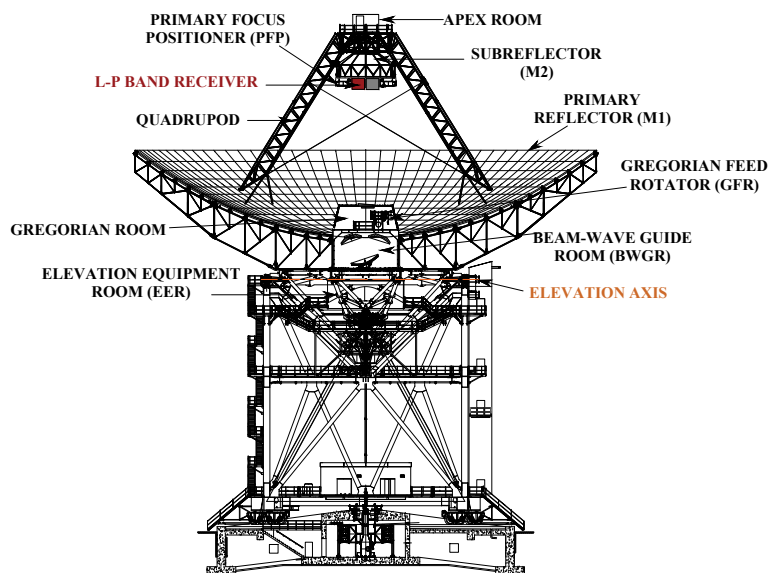
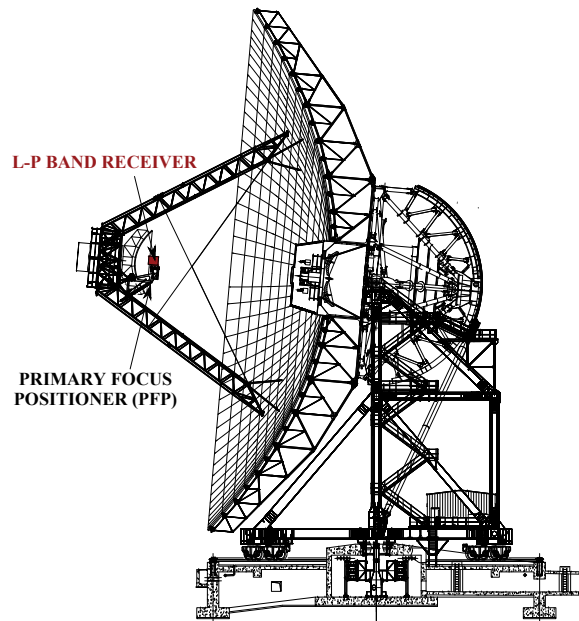

Figure 1. Location of the Sardinia Radio Telescope's optic systems.

Different receivers can be hosted in each focal position by servo-assisted devices that can select the desired one in a short time on the order of minutes (see Figure 2). The automated mechanical systems are listed below:

- Gregorian Feed Rotator (GFR), located in the Gregorian room;
- Primer Focus Positioner (PFP), fixed to the SRT quadrupod allowing receivers to be positioned in the primary focus;
- Servo-system for rotating mirror (M3) in the BWG room.



**Figure 2.** Location of the Primer Focus Positioner (PFP).

It is important to say that an amount of the PON funding has been allocated to increase the receiver fleet. In addition, the antenna performance upgrade, also includes the design and installation of a new PFP capable of housing more future receivers.

In this study the attention is focused on the metallic frame used to connect one of the three receivers placed in primary focus, i.e. the dual-frequency L-P receiver [6], to the PFP's switch system. The PFP is a steel structure fixed to the apex. Basically, it is composed of three parts: a main structure called Swing Frame that can rotate by means of swing screws in order to place the receivers in front of the subreflector (see Figure 3), a bogie called Translation Frame that allows the instrumentation to be moved in the direction parallel to the elevation axis, and a second bogie called Feed Carrier to which the receivers are bolted and that can translate along the optical axis.

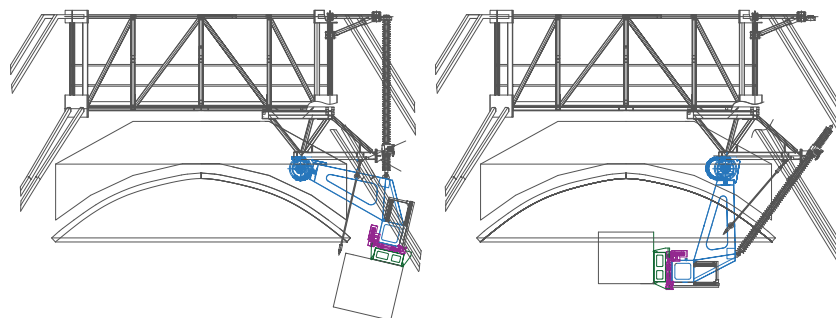

**Figure 3.** Representation of the two PFP position: the leftmost shows the PFP in the parking position, while the rightmost shows the PFP in the operating position. The Swing frame is represented in blue, the Translation Frame is represented in purple and the Feed Carrier is represented in green.

Given the characteristics of the moving systems and the critical geometric position of the loads in the overall SRT structure, the receivers must meet precise specifications with respect to both size and maximum weight. In fact, receiving systems must be placed in specific boxes that must not exceed a total of 4 m in length (dimension parallel to the axis of elevation), 1.4 m in height, 1.5 m in depth and 1 700 kg in weight. For this reason, the connecting frames must be lightweight while providing adequate strength and displacements contained within acceptable limits. Thus, the focus of this work was to evaluate the adequacy of the current support system to resist the loads produced by new receivers. Moreover, the second goal was to design a new support that can provide the same performance but with less weight. Structural analyses have been conducted according to a modeling approach based on the finite element method (FEM) by means of the commercial software Ansys Workbench 2022 R2 [7][8].

After this brief introduction, a description of the currently used support frame is given in Section 2. Next, in Section 3 the structural analysis performed on the frame under study is presented. In Section 4, the study conducted on an alternative model of the existing support is provided. Finally, the resulting final considerations.

## 2 DESCRIPTION OF EXISTING FRAME

This Section describes the support currently in use (see Figure 4). It is a cantilever system consisting of three main parts: two side shelf brackets and a plate arranged on the top.



**Figure 4.** Current frame structure for the L-P band receiver

Each shelf bracket consists of three main elements ( indicated with A, B and C in Figure 5) and two internal stiffeners. Elements A and B are joined at  $90^\circ$  angle, while the angle between element A and element C is  $60^\circ$ . The A element has 4 flat profiles that allow the support to be stiffened with transverse elements. The shelf brackets and the plate are connected to the Feed Carrier through 17 bolted joints. In addition, the frame system is designed in order to compose a modular system whereby two plates are placed side by side supported by three consecutive shelf brackets. The plate is bolted to the shelf brackets and has a central hole made to accommodate the receiver, which is fixed to the system by bolted unions along the flange. The support is entirely made of aluminum alloy EN AW-6082 UNI 9006/4 called Anticorodal. Table 1 shows the mechanical properties adopted to model the material which are considered valid under the environmental temperature condition (UNI EN 1706:2021).

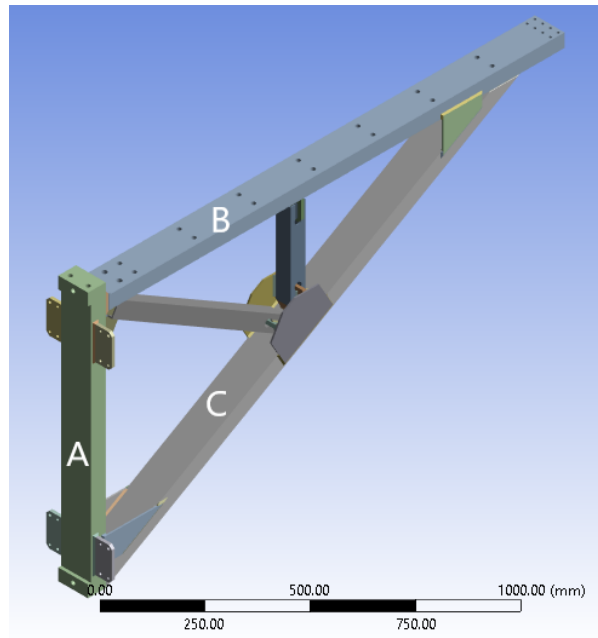

**Figure 5.** Shelf bracket of the current frame for the L-P band receiver; the letters identify the main parts that make up the subcomponent.

**Table 1.** Aluminum alloy EN AW-6082 UNI 9006/4 mechanical properties.

Density	[ $g/cm^3$ ]	2.69
Coefficient of thermal expansion	[ $^{\circ}C^{-1}$ ]	$23.40e - 06$
Young's Modulus	[MPa]	69 000
Poisson's Coefficient	[-]	0.3
Tensile Yield strength Coefficient	[MPa]	260
Tensile Ultimate strength Coefficient	[MPa]	310

### 3 FINITE ELEMENT ANALYSIS (FEA)

The finite element method (FEM) is an analysis technique widely used not only in structural calculations but also for problem solving in multiple engineering applications [9]. In particular, it represents a method for numerically solving partial differential equations by approximating them with a system of algebraic equations. However, an approximate solution close to the exact solution can be achieved if the model correctly idealizes the as built. This makes the problem mathematically easier, but still capable of providing approximate acceptable solutions. A continuous domain is therefore approximated with a mesh of finite elements in which the continuity is guaranteed only at the nodes.

When approaching the study of a mechanical component structural behavior, it is essential to define the geometries, constraints, and load conditions in such a way that they are representative of the actual conditions of the system under investigation. Thus, the methodology allows the simulation of many different stress conditions to which the structure is subjected, in order to characterize its response and judge its suitability for planned use. So, for an accurate assessment of both deformation and stress condition, loads must be properly evaluated.

One of the aspects that must be taken into account is that the PFP is moved to switch from the parking configuration to the operational one and vice versa, by turning around an axis parallel to the elevation axis (as seen in Figure 3). In addition, the Sardinia Radio Telescope is a fully steerable antenna. These two features require that the structural behavior of the analyzed frame must be investigated under various positions. This is because gravitational action stresses the structure in a different way depending on the direction in which it acts. Therefore, three shelf positions have been analyzed, representative of the whole range of possible orientations:  $+90^{\circ}$ ,  $0^{\circ}$  and  $-90^{\circ}$  (Figure 6).

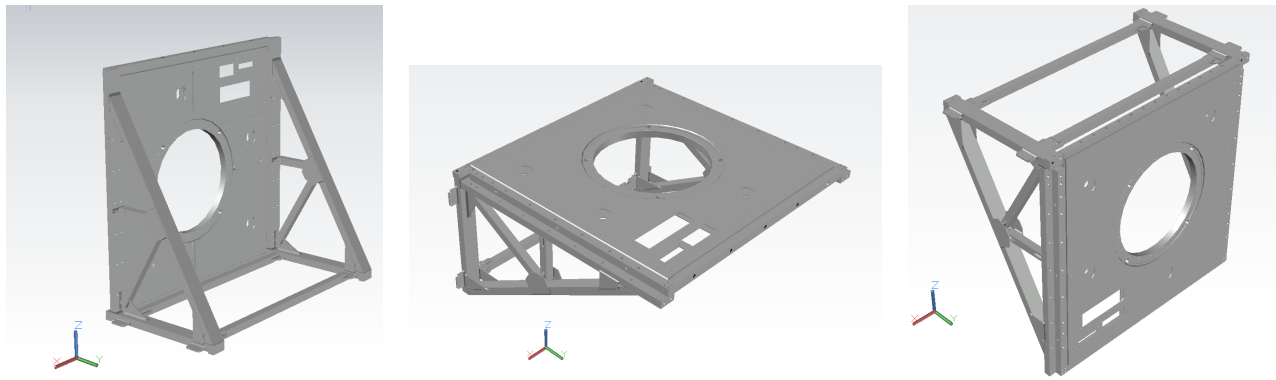

**Figure 6.** Representation of the three shelf positions analyzed by FEM: On the left the position in which the component orientation angle is set to  $+90^\circ$ , in the middle the position in which the component orientation angle is set to  $0^\circ$ , on the right the position in which the component orientation angle is set to  $-90^\circ$ .

At first, the load applied to the model have been set equal to 700 kg (6 867 N) since the weight of the L-P band receiver is close to that value. As shown in Figure 7, the load has been distributed on the contact surface between plate and receiver indicated in red, along the flange. This area is equal to  $1.11E + 05 \text{ mm}^2$ . In this way, the adopted pressure takes the value of 0.06 MPa. In addition, it must be take into account the self-weight of the component having a mass and volume equal respectively to 236 kg and  $8.80E + 07 \text{ mm}^3$ .

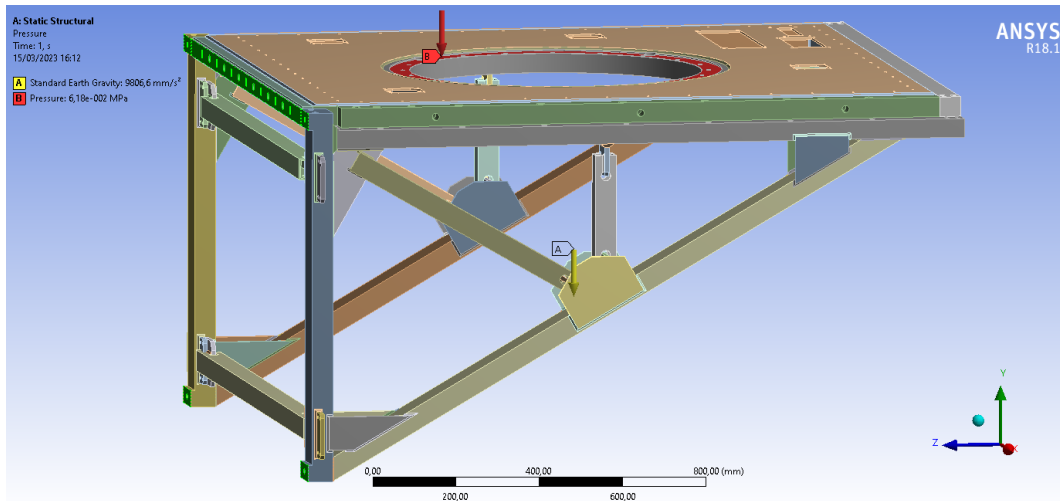

**Figure 7.** Indication of the loads considered in the mechanical support structural analysis. It should be noted that the direction of the vectors is representative of the case in which the orientation angle is set to  $0^\circ$ . Moreover, red is used to identify the pressure generated by the receiver, while yellow is used for the gravitational acceleration. Bright green faces identify areas where perfect interlocking constraint conditions have been imposed.

The 3D model realized by Autodesk Inventor CAD modeling software [10] has been imported into Ansys Mechanical environment for modeling by Finite Element Method [11]. The model consists of 639 908 nodes and 318 355 elements divided into the types SOLID186 and SOLID187. On the other hand, the contact areas are modeled with CONTA174 elements [12]. The mesh density has been controlled by the software, and the minimum achieved linear dimension of the elements is 0.61 mm. Perfect interlocking constraint conditions have been imposed in the areas indicated by the bright green color in Figure 7. This is because the PFP feed carrier has been considered non-deformable to evaluate only the displacement due to the shelf. Different linear static analyses have been conducted by means of Ansys Mechanical software, in order to estimate the maximum displacements and stress states achieved by the structure under the load conditions introduced above. In Figure 8, the displacements achieved in the three analyzed positions are indicated with a color gradation. On the other hand, Table 2 shows the maximum displacements, the maximum stress and the safety factor referred to the material yield strength.

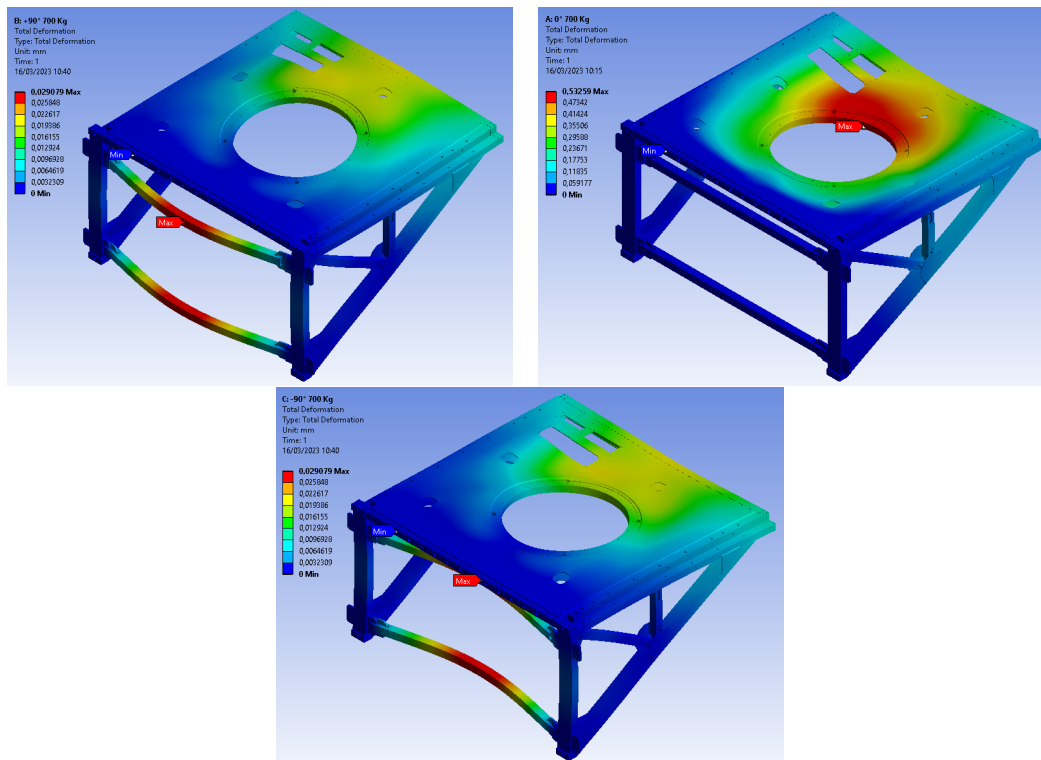

**Figure 8.** Representation of the total displacement in the three current shelf positions analyzed by FEM: in the upper left the case in which the shelf orientation angle is set to +90°; in the upper right the case in which the shelf orientation angle is set to 0°, in the bottom center the case in which the shelf orientation angle is set to -90°.

**Table 2.** Summary of the most significant FEAs results related to the current receiver support.

Orientation angle	[°]	+90	0	-90
Maximum total displacement	[mm]	0.03	0.53	0.03
Maximum stress	[MPa]	4.74	84.88	4.74
Minimum safety factor	[-]	> 15	3.06	> 15

The results reveal that the maximum values of displacement and stress are achieved in the case study at 0° orientation angle, in which they respectively assume the values of 0.53 mm and 84.88 MPa. It is important to note that in this case the maximum displacement is recorded in the plate. This aspect certainly influences the position of the receiver with respect to the non-deformed condition. However, values are in the order of magnitude of a tenth of a millimeter, a quantity considered acceptable taking into account performance requirements at wavelengths in the L-P frequency bands. Concerning the stress condition, the safety factor with respect to material yield strength equal to the value 3.06 suggests that the design solution implemented is capable to meet the safety requirements. Therefore, the obtained results show that the component can satisfy the desired performance under both operating and parking conditions.

It is interesting to assess the support's suitability for use in installing other receivers that may be heavier. For this purpose, the load has been increased in steps of 100 kg until the maximum displacement considered acceptable for operating conditions, i.e., 1 mm, has been exceeded. In Table 3, only the results of the condition where the frame is in the most critical position (0°) are reported.

**Table 3.** Summary of the most significant FEAs results related to the current receiver frame. Results refer to the conditions where the frame is in the most critical position (0°) and the receiver weights correspond to 800 kg ÷ 1400 kg.

Receiver weight	[kg]	800	900	1000	1100	1200	1300	1400
Maximum total displacement	[mm]	0.60	0.67	0.73	0.80	0.87	0.94	1.00
Maximum stress	[MPa]	96.26	107.65	119.16	130.54	141.92	153.43	164.81
Minimum safety factor	[-]	2.70	2.42	2.18	1.99	1.83	1.69	1.58

It can be seen that the frame is able to meet the required performance up to the load value of 1300 kg. In fact, under this condition, the maximum displacement, maximum stress and factor of safety with respect to material yielding take values of 0.94 mm, 153.43 MPa and 1.69, respectively. Next, when the structure is stressed with 1400 kg, the maximum displacement reaches the limit value. However, the safety factor always greater than 1 reveals the suitability of the solution.

#### 4 STUDY OF AN ALTERNATIVE FRAME MODEL

Although the structural solution adopted can adequately meet the performance requirements, a study for an alternative design proposal has been conducted with the aim to reduce the weight of the cantilever system. In fact, this would be an advantage for the whole mechanical and structural system of the PFP, proportional to the number of receivers that could be installed. In the new frame model, the plate is the only unchanged element, while the shelf brackets and cross stiffeners have been redesigned. The material chosen for the new parts is structural steel for carpentry, whose mechanical properties are given in Table 4.

**Table 4.** Structural Steel mechanical proprieties.

Density	[g/cm <sup>3</sup> ]	7.85
Coefficient of thermal expansion	[°C <sup>-1</sup> ]	1.2e – 05
Young’s Modulus	[MPa]	210 000
Poisson’s Coefficient	[-]	0.3
Tensile Yield strength Coefficient	[MPa]	250
Tensile Ultimate strength Coefficient	[MPa]	460

Commercial profiles with L-section 45x45x4.5mm and C-section 40x20x5mm have been adopted to make up the frame shelf brackets, while flat elements have been used to ensure the joint between the profiles just mentioned, as well as the connection to the Feed Carrier. The occurrence of possible galvanic corrosion phenomena at the interface between the steel of the shelf brackets and the aluminum of the plate can be prevented through insulation of the two materials. It should be noted that the weight achieved by the new structural system is 200 kg with a reduction of 36 kg compared to the current component. Once again, Finite Element Analyses (FEA) have been conducted using Ansys Mechanical software. At first, the three frame positions studied above have been analyzed, considering the load produced by the receiver corresponding to 700 kg. The model shown in Figure 9 consists of 589 451 nodes and 296 046 elements. The latter are divided among SOLD186, SOLID187 and finally CONTA174 types for contacts.

Linear static analyses have provided the displacement and stress values shown in Figure 10 and Table 5.

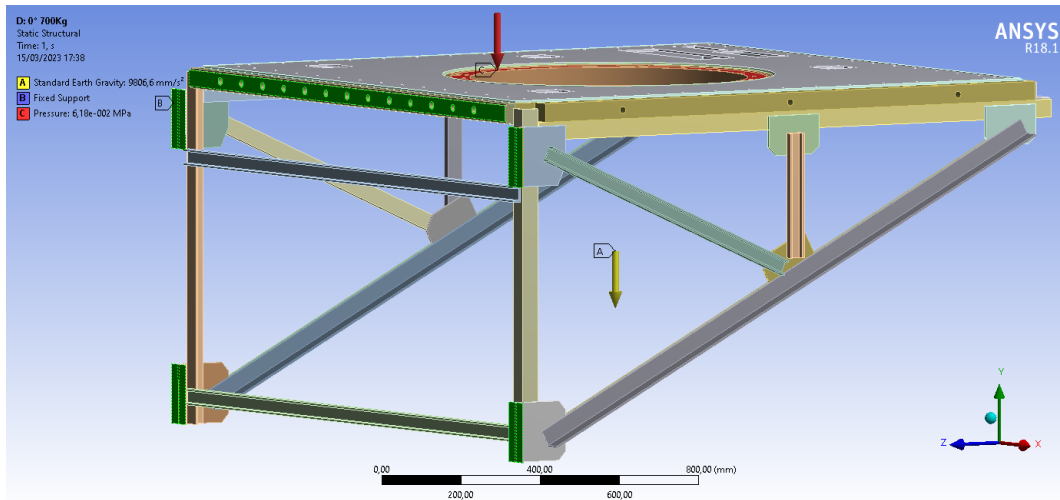

**Figure 9.** Indication of the loads and constraints areas in the alternative frame model. It should be noted that the direction of the vectors is representative of the case in which the orientation angle is set to  $0^\circ$ . Besides, red is used to identify the pressure generated by the receiver, yellow is used for the gravitational acceleration, and bright green is used to indicate the considered constraint areas.

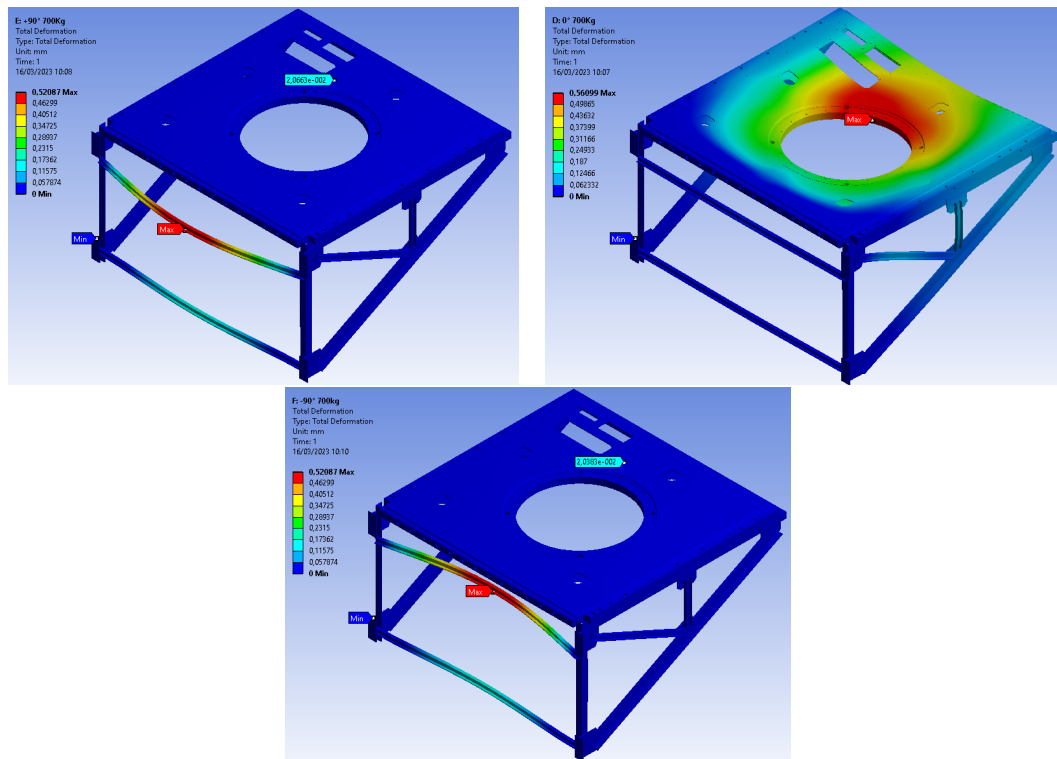

**Figure 10.** Representation of the total displacement in the three alternative frame positions analyzed by FEM: in the upper left the case in which the shelf orientation angle is set to  $+90^\circ$ ; in the upper right the case in which the shelf orientation angle is set to  $0^\circ$ , in the bottom center the case in which the shelf orientation angle is set to  $-90^\circ$ .

**Table 5.** Summary of the most significant FEAs results related to the alternative frame model.

Orientation angle	[°]	+90	0	-90
Maximum total displacement	[mm]	0.52	0.56	0.52
Maximum total plate displacement	[mm]	0.02	0.56	0.02
Maximum stress	[MPa]	7.57	136.53	7.57
Minimum safety factor	[-]	> 15	1.90	> 15

Results show that the critical condition of load is reached in the position with orientation angle set to 0°, in terms of both displacements and maximum stress. Although the maximum displacements recorded in this case are still on the order of a tenth of a millimeter, it can be seen that in the alternative frame these are larger than in the previous model. Unlike in the as built, displacements on the order of a tenth of a millimeter are achieved in the new model also in the cases with +90° and -90° orientation angle. Nevertheless, these values are detected in the transverse stiffening elements. On the other hand, the maximum displacements achieved in the plate are on the order of a hundredth of a millimeter even in the new version of the frame. Moreover, it can be seen that, in all the cases analyzed, the stress safety factor is greater than 1, allowing the structure suitable to meet the performance requirements.

Even for the new frame, it is interesting to analyze the structural behavior when subjected to loads progressively higher than 700 kg, in order to assess which load condition generates displacements greater than the acceptable value. Table 6 describes both the displacement and stress values determined considering the 0° frame position.

**Table 6.** Summary of the most significant FEAs results related to the alternative frame. Results refer to the conditions where the frame is in the most critical position (0°) and the receiver weights correspond to 800 kg ÷ 1400 kg.

Receiver weight	[kg]	800	900	1000	1100	1200	1300	1400
Maximum total displacement	[mm]	0.63	0.70	0.78	0.85	0.92	0.99	1.06
Maximum stress	[MPa]	154.86	173.20	191.75	210.08	228.42	246.97	265.09
Minimum safety factor	[-]	1.68	1.50	1.36	1.24	1.14	1.05	0.98

Concerning displacements, maximum values are on the order of a tenth of a millimeter as long as the receiver weight is 1300 kg. On the other hand, for the load value equal to 1400 kg, the displacements in the plate exceed 1 mm, which is the acceptable limit for the parameter. In addition, it can be seen that the maximum stresses in the alternative frame are greater than those estimated in the actual structure. Besides, when the load is 1400 kg, the safety factor reaches values less than 1 in the plate. This implies that the new design cannot meet safety requirements if the receiver's weight is greater than 1300 kg.

## 5 CONCLUSIONS

A few aspects emerge from this study that are worth to be discussed. The existing structure, made entirely of aluminum alloy EN AW-6082 UNI 9006/4 results adequate to support not only the load equal to 700 kg relative to the L-P band receiver, but also the load conditions up to 1300 kg. In fact, although the stress values meet the material strength requirements in all cases analyzed, when the load is 1400 kg the displacements exceed the acceptable limit value of 1 mm.

The same load conditions acting on a new frame model designed to reduce the total weight of the cantilever system, have been simulated. Unlike the as built, the new solution is designed as a mixed steel/EN AW-6082 UNI 9006/4 structure. In particular, the material adopted for the shelf brackets is structural steel, while aluminum alloy is used for the plate, which has remained unchanged. The new design has reduced the weight from 236 kg to 200 kg with a variation of 36 kg. This also implies a reduction in the overall load acting on the PFP, proportional to the number of receivers installed. Performed FEAs have revealed that slightly larger deformations ( $\geq 6\%$ ) are achieved in the alternative frame than in the existing structure. However, the new solution can be considered acceptable for operating conditions as long as the receiver weight is less than or equal to 1300 kg. In fact, in the case where the receiver weight is 1400 kg both displacements and stresses exceed the maximum acceptable values.

For the reasons described above it can be stated that, except for a weight reduction of about 15%, no particular improvements could be made to the current frame. As matter of fact, it is designed to be already optimized in terms of weight/performance ratio. A possible advantage of using the alternative model of the frame could be found in the construction and assembly process. This aspect is related to the availability, and thus to the quick provisioning, of commercial profiles compared to aluminum bars that need to be customized. In addition, the new solution proposes bolted unions with through-holes as a replacement for threaded holes. Indeed, the through holes solution simplifies the maintenance process.

Furthermore, this work leaves room for research into other alternative materials that might be able to provide better performance than those achieved by the design solutions investigated so far. Finally, the analysis of dynamic behavior will be the subject of further study.

## ACKNOWLEDGMENTS

The Enhancement of the Sardinia Radio Telescope (SRT) for the study of the Universe at high radio frequencies is financially supported by the National Operative Program (Programma Operativo Nazionale - PON) of the Italian Ministry of University and Research "Research and Innovation 2014-2020", Notice D.D. 424 of 28/02/2018 for the granting of funding aimed at strengthening research infrastructures, in implementation of the Action II.1 - Project Proposals PIR01 00010 and CIR01 00010.

The work was carried out as part of a training internship resulting from a collaboration between INAF-OAC Osservatorio Astronomico di Cagliari and DIMCM, Dipartimento di Ingegneria Meccanica, Chimica e dei Materiali, Università degli Studi di Cagliari.

## REFERENCES

- [1] Pietro Bolli, ANDREA Orlati, LUCA Stringhetti, ALESSANDRO Orfei, SIMONA Righini, R Ambrosini, MARCO Bartolini, CLAUDIO Bortolotti, Franco Buffa, Marco Buttu, et al. Sardinia radio telescope: general description, technical commissioning and first light. *Journal of Astronomical Instrumentation*, 4(03n04):1550008, 2015.
- [2] ISABELLA Prandoni, MATTEO Murgia, ANDREA Tarchi, MARTA Burgay, PAOLA Castangia, ELISE Egron, F Govoni, A Pellizzoni, R Ricci, S Righini, et al. The sardinia radio telescope—from a technological project to a radio observatory. *Astronomy & Astrophysics*, 608:A40, 2017.
- [3] Federica Govoni, Pietro Bolli, Franco Buffa, Letizia Caito, Ettore Carretti, Giovanni Comoretto, Davide Fierro, Andrea Melis, Matteo Murgia, Alessandro Navarrini, et al. The high-frequency upgrade of the sardinia radio telescope. In *2021 XXXIVth General Assembly and Scientific Symposium of the International Union of Radio Science (URSI GASS)*, pages 1–4. IEEE, 2021.
- [4] R Ambrosini, A Bocchinu, P Bolli, F Buffa, M Buttu, A Cattani, N D'amico, GL Deiana, A Fara, F Fiocchi, et al. The sardinia radio telescope: Overview and status. In *2013 International Conference on Electromagnetics in Advanced Applications (ICEAA)*, pages 82–85. IEEE, 2013.
- [5] Pietro Bolli, Franco Buffa, Letizia Caito, Ettore Carretti, Giovanni Comoretto, Davide Fierro, Federica Govoni, Andrea Melis, Matteo Murgia, Alessandro Navarrini, et al. Status of the high-frequency upgrade of the sardinia radio telescope. *URSI Radio Science Letters*, 3:26, 2021.
- [6] Giuseppe Valente, Tonino Pisanu, Alessandro Navarrini, Pasqualino Marongiu, Alessandro Orfei, Sergio Mariotti, Renzo Nesti, Juri Roda, Alessandro Cattani, Pietro Bolli, et al. The coaxial lp cryogenic receiver of the sardinia radio telescope. *IEEE Access*, 10:2631–2645, 2021.
- [7] Xiaolin Chen and Yijun Liu. *Finite element modeling and simulation with ANSYS Workbench*. CRC press, 2018.
- [8] Tadeusz Stolarski, Yuji Nakasone, and Shigeka Yoshimoto. *Engineering analysis with ANSYS software*. Butterworth-Heinemann, 2018.
- [9] Klaus-Jürgen Bathe. Finite element method. *Wiley encyclopedia of computer science and engineering*, pages 1–12, 2007.
- [10] Curtis Waguespack. *Mastering Autodesk Inventor 2014 and Autodesk Inventor LT 2014: Autodesk Official Press*. John Wiley & Sons, 2013.
- [11] Mary Kathryn Thompson and John M Thompson. *ANSYS mechanical APDL for finite element analysis*. Butterworth-Heinemann, 2017.
- [12] ANSYS. Ansys mechanical apdl element reference guide, 2020.

Author	E-mail	Contribution
Alessandro Attoli	alessandro.attoli@inaf.it	Finite Element Analysis and alternative frame model design
Riccardo Simoni	r.simoni@studenti.unica.it	Finite Element Analysis
Pasqualino Marongiu	pasqualino.marongiu.inaf.it	Finite Element Analysis and design of both the current and the alternative frame
Juri Roda	j.roda@ira.inaf.it	Finite Element Analysis and design of the current frame
All authors collaborated on the report writing		

Author information: contacts, and contributions.

Acronym	
BWG	Beam Wave Guide
CAD	Computer-Aided Design
FEA	Finite Element Analysis
FEM	Finite Element Method
GFR	Gregorian Feed Rotator
PPF	Primer Focus Positioner
PON	National Operational Program
SRT	Sardinia Radio Telescope