



Publication Year	2020
Acceptance in OA	2023-11-13T15:18:33Z
Title	Exploitation of bi-static radar architectures for LEO Space Debris surveying and tracking: The BIRALES/BIRALET project
Authors	Podda, A., CASU, Sergio, Coppola, A., Protopapa, F., Sergiusti, A.L., PISANU, Tonino, URRU, Enrico, SCHIRRU, Luca, ORTU, Pierluigi, GAUDIOMONTE, Francesco, BIANCHI, GERMANO, BORTOLOTTI, Claudio, ROMA, MAURO, PUPILLO, Giuseppe, LAMA , LUCA, PERINI, FEDERICO, SCHIAFFINO, MARCO, Maccaferri, A., NALDI, Giovanni, MATTANA, Andrea, Di Lizia, P., Purpura, G., Massari, M.
Publisher's version (DOI)	10.1109/RadarConf2043947.2020.9266345
Handle	http://hdl.handle.net/20.500.12386/34475
Serie	PROCEEDINGS OF THE IEEE NATIONAL RADAR CONFERENCE

Exploitation of bi-static radar architectures for LEO Space Debris surveying and tracking: the BIRALES/BIRALET project

Angelo Podda, Sergio Casu, Antonio Coppola,
Fabio Protopapa, Andrea Lazzareschi Sergiusti
Vitrociset S.p.A.
Via Tiburtina 1020, 00156 Roma, Italy

Germano Bianchi, Claudio Bortolotti, Mauro
Roma, Giuseppe Pupillo, Luca Lama, Federico
Perini, Marco Schiaffino, Andrea Maccaferri,
Giovanni Naldi, Andrea Mattana
Istituto Nazionale di Astrofisica – Istituto di
Radioastronomia (INAF – IRA)
Via Fiorentina 3513, 40059 Medicina (BO), Italy

Tonino Pisanu, Enrico Urru, Luca Schirru,
Pierluigi Ortu, Francesco Gaudiomonte
Istituto Nazionale di Astrofisica – Osservatorio
Astronomico di Cagliari (INAF – OAC)
Via della Scienza 5, 09047 Selargius (CA), Italy

Pierluigi Di Lizia, Giovanni Purpura, Mauro
Massari
Politecnico di Milano – Dipartimento di Scienze e
Tecnologie Aerospaziali
Via La Masa 34, 20156 Milano, Italy

Abstract—The space debris population is continuously growing and it represents a potential issue for spacecraft. New collisions could exponentially rise the amount of debris and so the level of risk represented by these objects. The monitoring of space environment is necessary to prevent new collisions. For this reason, radar measurements are relevant, in particular to observe objects in Low Earth Orbit. Regarding the Italian contribution, there are two radars based on two different radio telescopes as receivers: the BIRALES and the BIRALET systems. We propose a detailed description of these systems, focusing on hardware and software components that permit to perform range and range rate measurement of resident space objects.

I. INTRODUCTION

Space debris is defined as all inactive, fragments and human-made objects orbiting the Earth, at speeds up to 10 km/s [1], or reentering the atmosphere, with variable sizes and shapes. In near-Earth space, such as LEO (Low Earth Orbit), between 200 and 2000 km of altitude, these objects are more significant than natural meteoroids, with about 21000 officially catalogued objects with size down to 10 cm [2]. The consistent presence of space debris generates two types of risk: the in-orbit collision risk for every manned and unmanned spacecraft and the risks from reentering debris [3].

Space Situational Awareness (SSA) is referred as one of the capacitive areas of strategic interest to be developed / completed in the future in the short and medium term, for any nation with the target of the access to the space. One of the fundamental components is the European Space Surveillance and Tracking (EUSST) program, considered as the capability to build a spatial mapping of the objects in orbit, their classification and the exact identification of their orbital characteristics. Typically, with the aim to prevent collisions, space-based and ground-based systems have been used to monitor the space debris situation at various altitudes [4]. Ground-based measurements are carried out by means of state-of-the-art sensors, both radar and optical. Optical sensors are adopted to detect and track space debris

at higher orbits, e.g. Medium Earth Orbit (MEO), between 2000 and (below) 35786 km of altitude, and Geosynchronous Equatorial Orbit (GEO), at 35786 km, whereas radar sensors are employed at lower altitudes (LEO) [5].

II. RADARS: WORLDWIDE SCENARIO

Radar sensors are an essential part of the worldwide SST program, and they are spread all over the world. The United States, thanks to an extensive network of optical and radar sensors named Space Surveillance Network (SSN), is able to hold and maintain the largest database of catalogued objects in LEO [6]. The SSN radar sensors include phased arrays, reflector antennas, multi-static fences, and other types of radar that do not fall under the canonic SSN network, but are hosted by the US and could provide useful SSA data [7, 8]. The US Joint Space Operations Center (JSpOC) acts as coordinator for the large amount of data coming from the SSN, elaborating the orbital parameters and making them available in a standard format, i.e. the Two-Line Element set (TLE) [9].

After the US, Russia holds the second most important radar network for space debris observation. Among this sensor network, it is worth mentioning a few of them. The two Daryal-Radar located in Pechora (Russia) and Gabala (Azerbaijan), are both phased array in a bistatic configuration, working in VHF range (150-200 MHz) and capable of transmitting up to 350 MW [7, 8]. The same configuration is used by the Volga-type radar in Baranivichy (Belarus), operating at 3 GHz and by the Don-2N radar (also known as Pill Box) located in Moscow [7].

Regarding European situation, an important system available 24 hours a day for observations in survey mode is the Grand Réseau Adapté à la Veille Spatiale (GRAVES), a military continuous wave (CW) bi-static phased array radar operating at 143.05 MHz, located in Dijon (France) [10]. Another European radar sensor is the Tracking and Imaging Radar (TIRA) a powerful pulsed radar which can operate in monostatic or bi-static configuration. The bi-static

configuration is composed of the TIRA radar located at FGAN near Bonn as a transmitting antenna (Germany), and the Effelsberg Radio Telescope of the Max-Planck-Institute as a receiver [11]. It operates in L-Band, allowing the detection of objects with minimum size of 1 cm. Many others European systems are available in Spain, United Kingdom, France and Germany [12-15].

In recent years, the Italian contribution has continuously improved. In early 2017, Vitrociset Company engineers and the Italian National Institute for Astrophysics (INAF) researchers have conducted together, several studies to evaluate the suitability for the European Union Space Surveillance and Tracking (EUSST) program, to exploit the INAF Northern Cross radio telescope and the SRT (Sardinia Radio Telescope), as the receiving elements of a bi-static radar system for LEO space debris surveying and tracking strategy.

Together with the Vitrociset radio frequency transmitter (TRF), the radars are called respectively BIRALES (Bi-static Radar for LEO Survey) and BIRALET (Bi-static Radar for LEO Tracking) [16-20]. Following this approach, simulations were performed in order to validate and refine the preliminary system design of a radar compliant with the performances required by European Space Agency (ESA) in the frame of the European Program for SST (< 100 m radial accuracy, $< 0.1^\circ$ angular accuracy). Once the feasibility study was successfully completed, the final design stage of both radars started and the deployment of the system, both transmitter and receiver side, was completed. In this paper, we report the results of the analysis, the design and the deployment stage of the project BIRALES/BIRALET, nowadays operating in the frame of the European program SST. Finally, we will compare the field measurement results obtained and the values expected.

With respect to other European systems [10-15], we propose a different frequency (410-415 MHz) and a waveform that allows to measure both range and Doppler without ambiguities and with high precision, and avoiding complex signal processing. This aspect, in conjunction with the use of already existing receiving stations totally or partially involved for Astronomy observation, allowed the realization of a cost effective system able to measure range and Doppler of small LEO objects.

Exploiting the same transmitter, BIRALES can also use a multibeam system [16] to estimate the track of the object. This allow, in a single observation of a few seconds, and without the need to move the antennas, to measure the orbital parameters. Moreover, the use of BIRALET, thanks to SRT, improves the quality of data collected in space debris observations. In fact, the SRT is a powerful instrument that can rely on a comparable effective area but a fully steerable capability, with respect to the Northern Cross.

III. THE BIRALES AND BIRALET SYSTEM

The BIRALES system [16] is a bi-static radar operating at 410-415MHz and is currently composed by two distinct antennas (see Fig. 1), with a baseline of about 580 km:

- the receiver station is a part of the Northern Cross antenna array deployed at Medicina (close to Bologna, Italy);
- the radar transmitter station (called TRF) is deployed at Salto di Quirra Test Range (close to

Cagliari, Italy).

BIRALES is used for monitoring the space environment in survey mode. Table I shows the features of the system architecture.

This is a first prototype on which new radar technologies and orbital determination algorithms are being tested. In the coming months, an extension of the field of view up to 95° in the north-south direction is planned, to obtain an effective radar for surveillance. In order to achieve the new configuration, additional antennas of the Northern Cross will be used and an array of new emitters will be placed closer to the receiving part.

The receiver of BIRALES is a portion of the Northern Cross Radio Telescope (see Fig. 1 right) which consists of two perpendicular arms: the East-West (E/W) one is 564 m long and it consists of a single cylindrical antenna with a width of 35 m, whereas the North-South (N/S) arm is composed by 64 parallel parabolic cylindrical reflectors with a length of 23.5 m and a width of 7.5 m each.

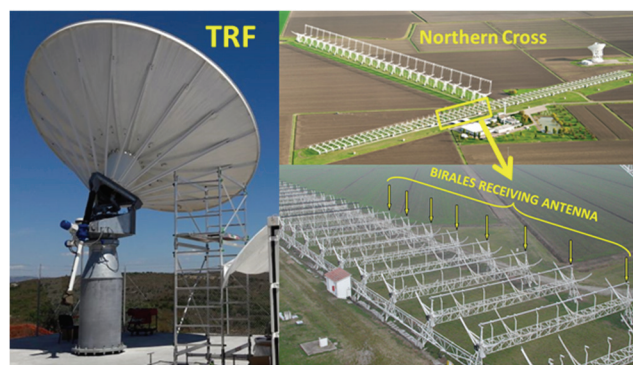

Fig. 1. The BIRALES system composed of the TRF (on the left) and the Northern Cross telescope (on the right).

The portion dedicated to the BIRALES receiver is actually composed of 8 parabolic cylindrical antennas of the N/S arm, with a total collecting area of about 1400 square meters and with a Field of View (FoV) of $5.7^\circ \times 6.6^\circ$. More details about the hardware architecture can be found in [17].

BIRALES is completely autonomous: the received echoes are immediately processed and the orbital parameters obtained are compared against the parameters of catalogued objects (through a correlator) in order to check whether the observed object is catalogued or not. If the observed object is not classified, the measured orbital parameters are uploaded into the European database and used, together with the other sensors data, for collision avoidance, fragmentation or re-entry services.

The BIRALET system (see Fig. 2) is a bi-static radar composed of the same transmitter used for the BIRALES one and the SRT as a receiver, with a baseline of about 20 km [18]. It is used for monitoring the space environment in tracking mode.

The receiving antenna, the SRT, is a fully steerable wheel-and-track 64 m radiotelescope, located near San Basilio (Cagliari, Sardinia, Italy). The front-end used for space debris monitoring is the L-P receiver, a cryogenically cooled coaxial receiver with two channels, one for the P band (305-410 MHz) and the other one for the L band (1300 – 1800 MHz) [18-20]. The main features of the

system are reported in Table I.



Fig. 2. The Sardinia Radio Telescope (SRT) as receiver of the BIRALET system.

The transmitting antenna, used for both radar, is the Radio Frequency Transmitter (TRF) located in Italian Joint Test Range in the region “Salto di Quirra” (Cagliari, Sardinia). It is a 7 m dish fully steerable parabolic antenna (see Fig. 1 left), with a maximum angular speed of 3 deg/sec. Fundamentally, the system is composed by a set of powerful solid-state amplifiers, installed in a cooled shelter, able to supply a maximum power of 10 kW in the bandwidth 404-415 MHz [2].

TABLE I. MAIN CHARACTERISTICS OF THE BIRALES AND BIRALET SYSTEMS.

	TRF	Northen Cross	SRT
Frequency of operation	404-415 MHz	410-415 MHz	402-416 MHz
Antenna Gain	26.0 dBi	45.3 dBi	46.6 dBi
Half Power Beam Width	7.5 deg	FOV: 5.7 deg x 6.6 deg Synthesized Beam: 0.52 deg x 1.73 deg	0.8 deg
Polarization	circular	linear	Circular and linear
Sidelobes	< -20dB	< -13dB	< -20dB
Noise Temp	NA	86 K	20 K

IV. THE BI-STATIC RANGING MEASURE SYSTEM

Figure 3 shows the architecture of the transmitter. An operator workstation is used to generate the I/Q samples of the transmitted waveform.

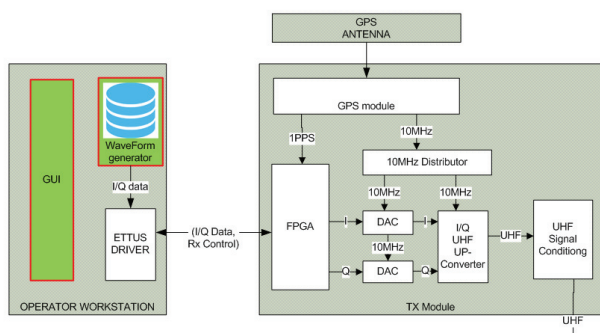

Fig. 3. Transmitter architecture

The I/Q samples are then converted in analogue signal by two 14-bit DAC and up-converted by the I/Q up-converter chip. This signal finally drives a 10 kW power amplifier and is transmitted towards the expected target

position (predicted using a TLE) or toward the sky area to be explored by the TX antenna.

Figure 4 shows the architecture of the receiver system. The UHF signal received by the Medicina antenna array is beam formed and down converted to a 30 MHz IF signal. In the SRT receiver system instead, the UHF signal is directly processed at 410 MHz, without any down conversion.

This signal is then down converted to baseband by an I/Q down converter chip and finally digitalized by two ADC. I/Q signals are then sent to the operator workstation for processing. The processing can be done both:

- In real time;
- Offline by using the real time stored I/Q samples. This functionality is extremely useful for testing purposes and to analyze further improvements of the radar processing chain.

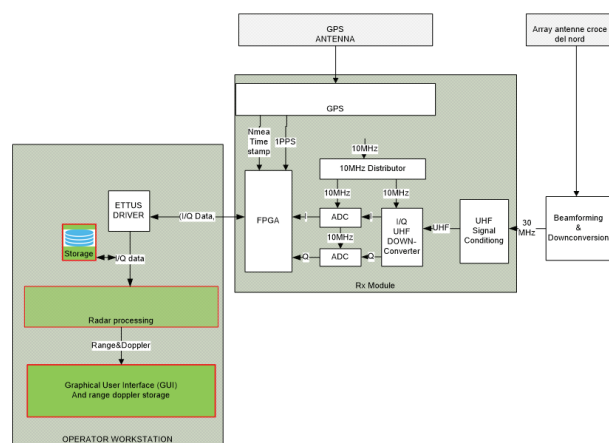

Fig. 4. Receiver architecture

The overall performance of a bi-static radar is affected by the precision in the synchronization between transmitter and receiver. For BIRALES/BIRALET the receiver and the transmitter are synchronized using the GPS 1PPS and the 10 MHz reference signals:

- 10 MHz signal is used as standard reference to generate all other frequencies used in transmitter and receiver systems (I/Q Down and Up Converter oscillators, DAC and ADC sampling frequencies).
- 1 PPS signal is used to start the acquisition/generation at the same time between receiver/transmitter.
- a maximum error of 10^{-7} s is guaranteed by an integrated GPS hardware

The waveform transmitted by TRF is a FMCW (chirp) plus a CW tone with an overall bandwidth of 5 MHz (Fig. 5).

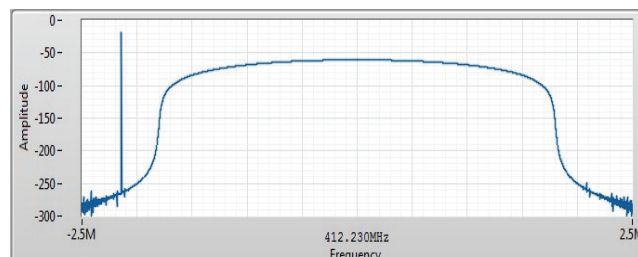

Fig. 5. Spectrum of transmitted signal

Up to now the following transmitted signal has been used:

- Central frequency 412.23MHz
- Linear FM up-chirp: PRI = 20 ms, PRF = 50 Hz, bandwidth 3.6 MHz
- CW tone at an offset of -2.145 MHz with respect to the central frequency

The sampling frequency is 5 MS/s and the maximum transmitted power is 10 kW with a 100% duty cycle. Using a 100% duty cycle allow us to exploit all the energy from the transmitter (there is no coupling between transmitter and receiver) and the 50 Hz PRF allow us to measure the range without ambiguities (the Doppler information, to compensate the range error, is extracted from the tone). Using a chirp with a span of 3.6 MHz allow us to exploit all the usable bandwidth maximizing the range resolution, leaving a small portion of the spectrum for the tone used for Doppler extraction, and allowing a Doppler shift of more than 100kHz (more than sufficient considering the expected target speed with the used carrier). For range extraction, in order to maximize the signal to noise ratio, the matched filter is used for pulse compression. Interpulse integration is also used: four chirps are integrated (see Fig 6). This means that we have a measure of the target range and Doppler every 80 ms (the step between measures is four pulses: $20 \text{ ms} * 4 = 80 \text{ ms}$). For Doppler calculation an FFT of 0.1s is performed, and the tone shift is measured.

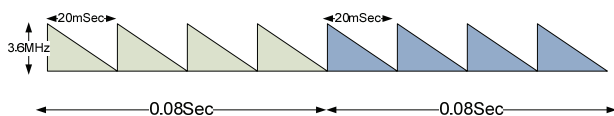

Fig. 6. FMCW pulse train

Even if up to now only the above described waveform has been used, the transmitted waveform is simply configurable using a file shared between the transmitter and the receiver. Sharing this information is crucial for the evaluation of the correlation between the transmitted signal and the received signal.

The system is able to perform three types of measurements:

- The Doppler, to measure the frequency shift of the CW tone.
- The bi-static range, by using the chirp pulse compression (the Doppler information from the tone is used to apply the correct matched filter for pulse compression). The chirp range compensation is performed using the Doppler information from the tone. From the tone we can also extract the speed (range rate) and the acceleration, to compensate the range migration in the inter-pulse integration.
- Estimation of the target trajectory (only for the multi-beam BIRALES system): when a space debris transits inside the antenna FoV, its echo radar illuminates a certain number of beams. Thus, by looking at the beam illumination sequence, it is possible to estimate the ground track of the transiting objects, with a higher level of details with respect to a single-beam system. The information about the sequence of illuminated

beams allows to recognize the trajectory of the object with an estimated orbit accuracy below 100 m.

Finally, all the measures are time stamped with a millisecond accuracy allowing precise target trajectory prediction.

V. PRELIMINARY RESULTS

A validation campaign of the BIRALES and BIRALET is currently underway aiming at assessing its performances. Targeted observations are performed by pointing the system towards calibration objects. The resulting measurements are compared against the associated accurate ephemerides. First, the observable passages of the objects are predicted, then the transmitter and the receiver are pointed accordingly, in order to observe them. Since more than one object may cross the field of view during the observation time window, each detected passage and the associated measurements undergo a correlation process against the whole TLE catalog. If a univocal match with a known object is identified, the measurement is associated to it and considered valid. Specifically, this is done by propagating the TLEs up to the observation epoch and checking that the Doppler shift and its time derivative have a mean error below a selectable threshold. It is also enforced that the predicted position of the object is compatible with the pointing of the receiving antenna.

The next step of the validation procedure concerns the slant range. Orbital propagation of the TLEs based on the Simplified General Perturbation Model SGP4 is not suitable for this purpose due to the possible inaccuracies of the predictions. Therefore, the campaign is focused on objects monitored by the International Laser Ranging Service (ILRS), which provides the positional state of the satellites with an accuracy of the order of the centimeter.

A. BIRALES results

Currently, around 80% of the detected passages are successfully correlated on a daily basis to objects in the public TLE database. The analysis has shown that the slant range value obtained by the system was constantly shifted with respect to the ILRS predictions: this is apparent in Fig. 7, which refers to a passage of satellite Jason-3 (SCN: 41240) on Sept. 27, 2019.

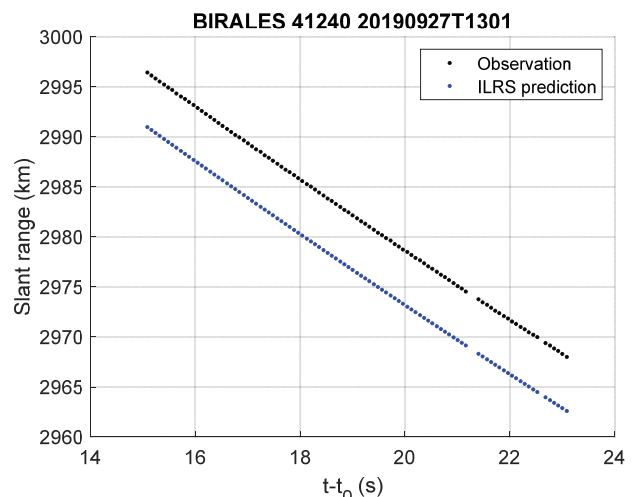

Fig. 7. Observed vs. predicted slant range during passage of sat. Jason-3 on 2019/09/27, no correction applied.

The results of the observation campaign, conducted on the passages of the objects from the ILRS catalogue reported in Table II, were used to analyze and estimate this bias, which turned out to have a mean value of 5,45613 km. This value was verified to be correlated with time delays in the measurement chain.

TABLE II. OBSERVED PASSAGES OF OBJECTS FROM THE ILRS CATALOGUE.

Sat. name	SCN	Epoch [UTC]	RCS [m ²]	Slant range [km]
Explorer-27	1328	2019/09/25 11:11	2.16	2024
Explorer-27	1328	2019/09/26 12:20	2.16	2250
Explorer-27	1328	2019/09/27 09:42	2.16	2100
Explorer-27	1328	2019/09/27 11:36	2.16	2134
Jason-3	41240	2019/09/27 13:02	2.89	2976
TechnoSat	42829	2019/09/30 08:58	0.39	1341
Explorer-27	1328	2019/09/30 09:23	2.16	2137
Explorer-27	1328	2019/10/07 06:06	2.16	2420
Explorer-27	1328	2019/10/07 08:00	2.16	2360

The system has been consequently calibrated. By correcting the slant range measurements by the estimated bias, the accuracy of the measurements is improved accordingly. This is shown in Fig. 8, which reports the slant range of the satellite Explorer 27 (SCN: 1328) on Sept. 30, 2019. With the correction applied, the RMSE between the observed and the predicted slant ranges for this passage turns out to be 80 m.

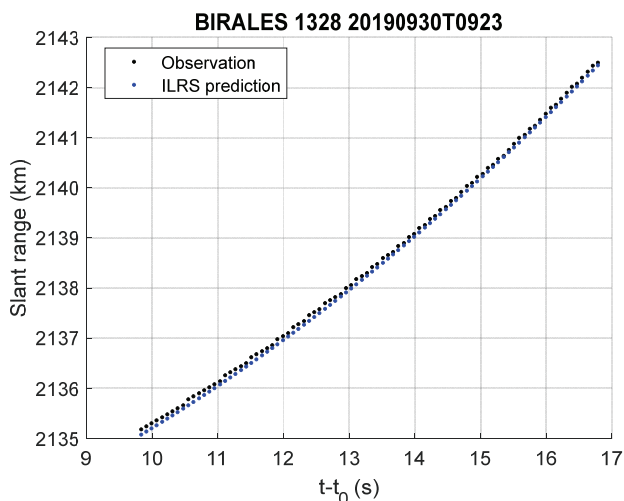

Fig. 8. Observed vs. predicted slant range during the passage of sat. Explorer-27 on 2019/09/30 after bias correction.

The calibration campaign is still ongoing, in order to confirm that the deviation of the measured slant range is compatible with the requirements of the EU-SST program. Afterwards, the calibration campaigns will be repeated periodically as requested by the EUSST program.

B. BIRALET results

The BIRALET system has been used in beam-parking mode, with the TRF and the SRT observing the same volume of space where was predicted the passage of the debris. This preliminary measurement campaign wants to validate the integration of the new ranging system.

A calibration measurement of the receiver chain was preliminary performed with the objective of investigating the delay of the received signal. In this way, we measured and compensated the time error, and consequently the range error, caused by the receiver chain length, from the SRT P-band receiver to the dedicated backend based on a National Instrument USRP 2954R board. This measurement was performed by generating a synthesized signal with the same board and sending it with a small antenna installed near the SRT. After this preliminary calibration, a set of ILRS objects were detected on 13 December 2019, to compare the measured Doppler and range with the data available on the associated accurate ephemerides. In Table III, for each observed object, we reported the slant-range error (in meters) and the Doppler error (in Hertz), obtained as the difference between the measured and the estimated value.

TABLE III. OBSERVED PASSAGES OF OBJECTS FROM THE CATALOGUE.

SCN	Epoch [UTC]	RCS [m ²]	Slant Range [km]	Doppler [Hz]	Slant Range error [m]	Doppler error [Hz]
16791	13/12/2019 09:07	7.36	1441	7973	-4	-3
36508	13/12/2019 09:53	2.97	1709	5235	67	-5
41335	13/12/2019 10:05	4.97	1742	-2898	-69	-32
40697	13/12/2019 10:30	3.4	1789	-7929	-35	-51
37387	13/12/2019 10:47	5.6	1940	-1712	-84	-28
40894	13/12/2019 10:59	3.7	1512	-4622	0	-38
5395	13/12/2019 11:15	1.58	1500	2800	75	10
11962	13/12/2019 11:26	5.07	1784	3163	-31	-3
38338	13/12/2019 11:54	5.3	2287	6029	40	11

From the analysis of the data (Table III), collected by the BIRALET system, it appears that we have a slant-range and a Doppler error compatible with the requirements requested by the EUSST program. However, the calibration measurement campaign must be repeated periodically in order to update these results and maintain these high performances of the system.

VI. CONCLUSIONS

The preliminary results described in this paper confirm that the measurements made with the bi-static radar, after calibration and bias correction, are accurate and comply with the design and simulations. There are different parameters in the processing chain that can be tuned in order to improve the quality and sensitivity of the measurement. For example, if the Doppler of the object is known, the SNR can be improved by 3 dB sending all the available transmitting power in the chirp.

Another improvement in the SNR can be done by increasing the integration time (increasing the number of integrated pulses) or the transmitted waveform. Many tests and system parameter tuning, can be done by processing off line, the real time stored I/Q samples. Further measurements and processing refinement will be done in the next months in order to assess and improve the performances of the system in terms of coverage and accuracy, using several targets with different RCS and orbiting altitudes.

ACKNOWLEDGMENTS

The research activities described in this paper were performed within the European Commission Framework Programme H2020 and Copernicus “SST Space Surveillance and Tracking” contracts No. 785257-2-3SST2016 and No. 237/G/GRO/COPE/16/8935-1SST2016. The Radio Frequency Transmitter is a facility operated by the Italian Air Force, located at Italian Joint Test Range of Salto di Quirra in Sardinia. The Northern Cross Radio Telescope is a facility of the University of Bologna operated under agreement by the National Institute for Astrophysics - Institute of Radio Astronomy (INAF-IRA).

REFERENCES

- [1] H. Klinkrad, “Hypervelocity Impact Damage Assessment and Protection Techniques”, in *Space Debris – Models and Risk Analysis*, Ed. Springer, 2006, pp. 199-205.
- [2] F. R. Hoots, P. W. Schumacher, R. A. Glover, “History of Analytical Orbit Modeling in the U.S. Space Surveillance System”, *Journal of Guidance Control and Dynamics*, vol.27, no. 2, pp. 174-185, Apr. 2004.
- [3] G. Muntoni, L. Schirru, T. Pisanu, G. Montisci, G. Valente, F. Gaudiomonte, G. Serra, E. Urru, P. Ortu, A. Fanti, “Space debris detection in Low Earth Orbit with the Sardinia Radio Telescope”, *Electronics*, vol. 6, no 3, pp. 1-16, August 2017.
- [4] M. Grassi, E. Cetin, A. Dempster, “Enabling Orbit Determination of Space Debris Using Narrowband Radar”, *IEEE Transaction on Aerospace and Electronic Systems*, vol. 51, no. 2, pp. 1231-1240, Jun. 2015.
- [5] F. Piergentili, F. Santoni, P. Seitzer, “Attitude Determination of Orbiting Objects from Lightcurve Measurement”, *IEEE Transactions on Aerospace and Electronic Systems*, vol. 3, no. 1, pp. 81-90, Feb. 2017.
- [6] H. Klinkrad, “The Current Space Debris Environment and its Sources”, in *Space Debris – Models and Risk Analysis*, Ed. Springer, 2006, pp. 5-18.
- [7] B. Weeden, P. Cefola, J. Sankaran, “Global Space Situational Awareness Sensors”, *Advanced Maui Optical and Space Surveillance (AMOS) Conference*, Maui, HI, USA, 14-17 Sept. 2010.
- [8] D. A. Vallado, J. D. Griesbach, “Simulating Space Surveillance Networks”, *Paper AAS 11-580 presented at the AAS/AIAA Astrodynamics Specialist Conference*, Girdwood, AK, USA, 31 Jul.-4 Aug. 2011.
- [9] P. Masekell, O. Lorne, “Sapphire: Canada’s Answer to Space-Based Surveillance of Orbital Objects”, *Advanced Maui Optical and Space Surveillance (AMOS) Conference*, Maui, HI, USA, 16-19 Sept. 2008.
- [10] J. Ender, L. Leushacke, L. Brenner, H. Wilden, “Radar Techniques for Space Situational Awareness”, *IEEE Proceedings International Radar Symposium (IRS)*, Leipzig, Germany, pp. 21-26, 7-9 Sept. 2011.
- [11] D. Mehrholz, L. Leushacke, R. Jehn, “The COBEAM-1/96 Experiment”, *Advances in Space Research*, vol. 23, no. 1, pp. 23-32, 1999.
- [12] H. Wilden, C. Kirchner, O. Peters, N. Ben Bekhti, A. Brenner, T. Eversberg, “GESTRA – A Phased-Array Based Surveillance and Tracking Radar for Space Situational Awareness”, *IEEE International Symposium on Phased Array Systems and Technology (PAST)*, Waltham, MA, USA, pp. 1-5, 18-21 Oct. 2016.
- [13] H. Klinkrad, “Monitoring Space – Efforts Made by European Countries”, *International Colloquium on Europe and Space Debris*, Nov. 2002.
- [14] I. A. Gomez, S. A. Vildarraz, C. Garcia, J. M. H. Garnica, C. Perez Hernandez, M. A. R. Prada, J. U. Carrazo, G. M. Pinna, S. Moulin, P. Besso, H. Krag, J. R. Benayas, P. Ortiz Sanz, A. Gallego Torrego, A. M. A. Sanchez, N. Sanchez Ortiz, R. Dominguez Gonzalez, N. Ortiz, “Description of the Architecture of the Spanish Space Surveillance and Tracking System”, *Proceedings of the 7th European Conference on Space Debris*, Darmstadt, Germany, 18-21 Apr. 2017.
- [15] D. Ladd, R. Reeves, E. Rumi, M. Trethewey, M. Fortescue, G. Appleby, M. Wilkinson, R. Sherwood, A. Ash, C. Cooper, P. Rayfield, “Technical Description of a Novel Sensor Network Architecture and Results of Radar and Optical Sensors contributing to a UK Cueing Experiment”, *Advanced Maui Optical and Space Surveillance (AMOS) Conference*, Maui, HI, USA, 19-22 Sept. 2017.
- [16] G. Pupillo, G. Bianchi, A. Mattana, G. Naldi, C. Bortolotti, M. Roma, M. Schiaffino, F. Perini, L. Lama, M. Losacco, M. Massari, P. Di Lizia, A. Magro, D. Cutajar, J. Borg, A. Maccaferri, S. Rusticelli and G. Purpura, “Operational Challenges of the Multibeam Radar Sensor BIRALES for Space Surveillance”, 1st International Orbital Debris Conference (IOC), Houston, Texas, United States, 9-12 December 2019.
- [17] T. Pisanu, L. Schirru, E. Urru, F. Gaudiomonte, P. Ortu, G. Bianchi, C. Bortolotti, M. Roma, G. Muntoni, G. Montisci, F. Protopapa, A. Podda, A. Sulis, G. Valente, “Upgrading the Italian BIRALES System to a Pulse Compression Radar for Space Debris Range Measurements”, *IEEE 22nd International Microwave and Radar Conference (MIKON)*, Poznan, Poland, 15-17 May 2018.
- [18] M. Losacco, L. Schirru, “Orbit Determination of Resident Space Objects Using the P-Band Mono-Beam Receiver of the Sardinia Radio Telescope”, *Applied Sciences*, vol. 9 (19), pp. 4092, 2019.
- [19] L. Schirru, T. Pisanu, A. Navarrini, E. Urru, F. Gaudiomonte, P. Ortu, G. Montisci, “Advantages of Using a C-band Phased Array Feed as a Receiver in the Sardinia Radio Telescope for Space Debris Monitoring,” *IEEE 2nd Ukraine Conference on Electrical and Computer Engineering (UKRCON)*, Lviv, Ukraine, 2-6 July 2019.
- [20] G. Muntoni et al., “A Space Debris-Dedicated Channel for the P-Band Receiver of the Sardinia Radio Telescope: A Detailed Description and Characterization,” in *IEEE Antennas and Propagation Magazine*, vol. 62, no. 3, pp. 45-57, June 2020, doi: 10.1109/MAP.2019.2943274.