



Publication Year	2007
Acceptance in OA	2024-02-07T14:05:57Z
Title	CSL optical shield: proposal for device measuring displacement
Authors	DE ROSA, Adriano Giuseppe, CUTTAIA, FRANCESCO, MORGANTE, GIANLUCA
Handle	http://hdl.handle.net/20.500.12386/34724
Volume	PL-LFI-PST-TN-081



TITLE: **CSL Optical Shield: proposal for device measuring displacement**

DOC. TYPE: **TECHNICAL NOTE**

PROJECT REF.: **PL-LFI-PST-TN-081** **PAGE:** **I of IV, 7**

ISSUE/REV.: **1.0** **DATE:** **December 2007**

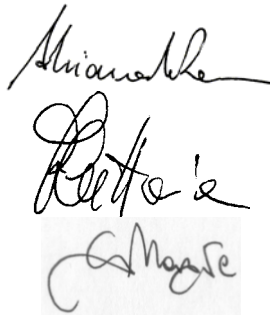
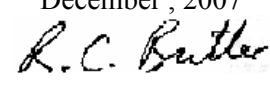
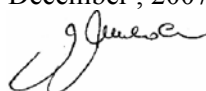
Prepared by	A.DE ROSA F. CUTTAIA G.MORGANTE	Date: December , 2007 Signature: 
Agreed by	C. BUTLER LFI Program Manager	Date: December , 2007 Signature: 
Approved by	N. MANDOLESI LFI Principal Investigator	Date: December , 2007 Signature: 



CHANGE RECORD

Issue	Date	Sheet	Description of Change	Release
0.1	December 2007	All	First Draft of Document	



TABLE OF CONTENTS

1	INTRODUCTION.....	1
1.1	PURPOSE AND SCOPE	1
2	DESCRIPTION.....	2
2.1	SYSTEM DESCRIPTION	2
2.2	MEASUREMENT LAYOUT	4
3	MICRO EPSILON SOLUTION.....	5
4	ANNEX	6



1 INTRODUCTION

"This document has been issued in the frame of ASI contract that has been released for the activities of Planck-LFI Phase E2"

1.1 Purpose and Scope

Scope of this document is to propose a possible conceptual sketch of a simple device for measuring the displacement of the CSL PLANCK optical shield, due to the thermal contraction of the support structures at cryogenic temperatures



2 Description

2.1 System description

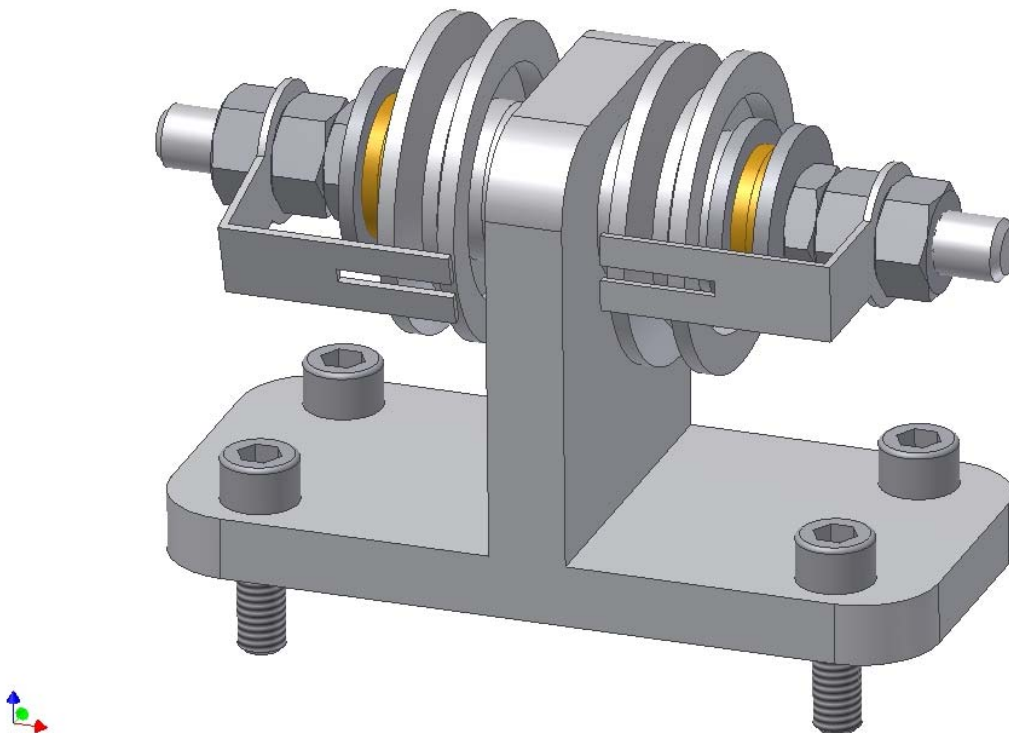

The basic idea to evaluate the displacement of the optical shield along one direction is to measure the unwinding of a wire. The system proposed is a simple pulley with no returning action on the wire: in this way, at the end of the blank test warm-up, the maximum displacement can be read without using any external (outside the cryo facility) instrumentation. In this frame, two devices per axis are required, since the direction of displacement is a priori unknown.

At the beginning of the test (1st step, warm condition), the wire is rolled on the pulley and tensioned. The cool down (2nd step) will produce a displacement of the optical shield: only the positive displacement (i.e. producing the unwinding of the wire) is registered, due to the lowest compression stiffness of the wire and the friction force acting on the pulley. For redundancy, each system is made by two coupled pulleys measuring about the same quantity..

Any of the steel alloys in the AISI 300 series would be a suitable material for such a system: in particular, AISI 304 or 316 seem to be the most viable choices. The same materials should be used for all the components, to guarantee the same thermal contraction. The wire can be made both of Kevlar or stainless steel.

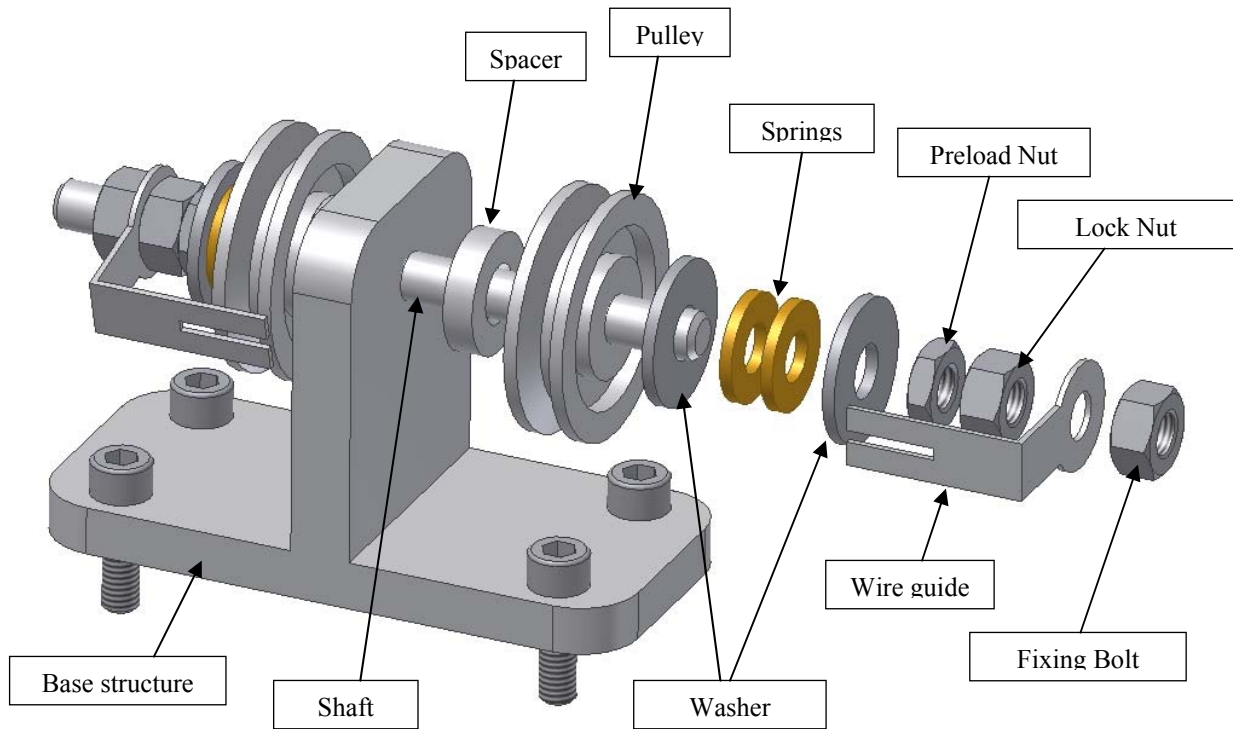

In the exploded view it is possible to identify all the components of the measurement system. The shaft can be welded to the base structure or fixed with screws. The spacer is needed to control the position of the pulley and the friction force. The pulley can run centred on the shaft due to a close mechanical tolerance (like H6/g5). No bearing is needed due to the small rotation angle and the small rotation speed. The Belleville springs are guided by the shaft and so there can be several possible combinations of springs providing the required stiffness. In order to obtain the necessary friction force on the pulley it is required to tighten the preload nut. A lock nut is then added to avoid preload loss (it is reasonable to think that the preload nut will not be tighten up to the fixing torque, because in this condition the pulley could not run. The wire is guided during its roll down by a “finger like” guide in order to maintain the right direction.

The intrinsic systematic errors affecting the precision of such a simple device are under evaluation. Anyway with this simple, fast and affordable system it could be possible to easily measure displacements of the order of several millimetres.



2.2 Measurement layout

In order to know the displacement of the optical shield at least 6 measurements units, 2 per axis, are needed. The system should be mounted on the cryofacility internal shroud and the terminals of wires connected to the optical shield itself (by using, for example, the screws foreseen to mount its cover) or to its support flange (that is the copper flange topping the Helium tank). The overall dimensions of the system are about 120x80x100.

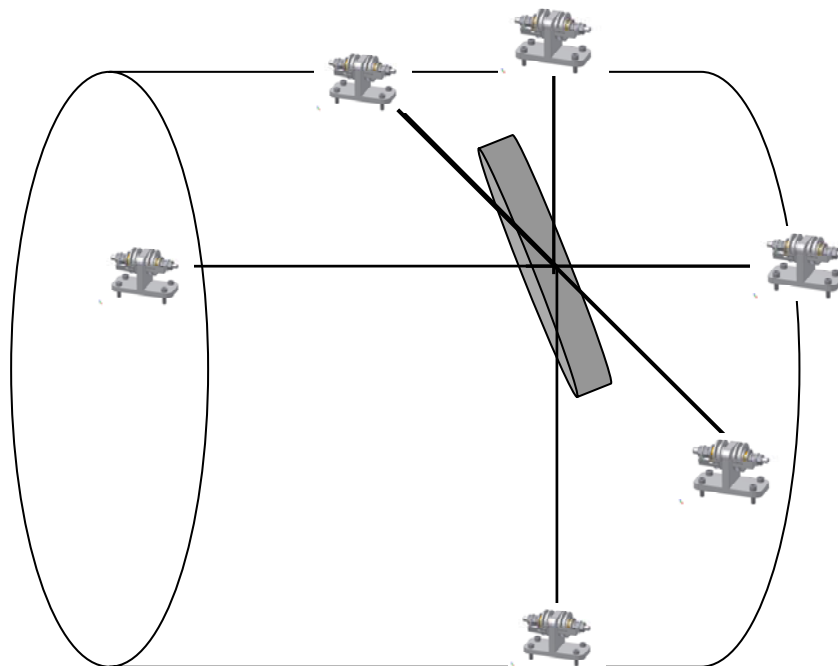



3 Micro epsilon solution

A wire displacement measurement system is actually used on the ESA Ariane mounted on the booster rocket. The measurement system is built by the Micro Epsilon and its code number is WDS-500-MP-P-SPL and can be used at temperature as low as -250°C . With this system is also possible to know the position of the optical shield during all the cool down. In the annex is reported the technical data of this product.



4 Annex



A043_e
 Draw-wire displacement sensors
wireSENSOR



Release of satellites into space

In order to be able to launch a satellite from the Ariane rocket unobstructed into space, the nose cone section, together with the side shield, have to be separated from the main rocket immediately before the release of the satellite.

Simultaneous and controlled activation of a series of preloaded springs, provide the propulsion force for the separation of the nose cone and side shield.

It is of vital importance that the section separates itself in an absolute linear motion from the main rocket, without any non-linear tumbling movement that could cause damage to the satellite.

The separation movement is controlled by 3 Draw-wire sensors mounted on the booster rocket. The ends of the draw wires are attached to the nose cone section via a preset and rated breaking point connector. These connectors automatically disconnect the wire from the nose cone at the end of the measuring-range of the sensor.

Immediately following the separation of the draw-wire from the nose cone section, the draw wire is automatically retracted in its housing, in order to avoid damage to the satellite during its subsequent separation from the carrier.

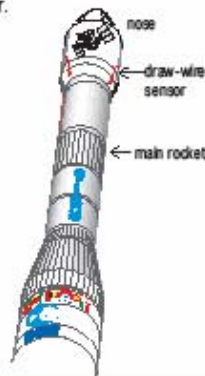

Technical details

- Measuring range: 500 mm
- Resolution: 0,1 %

System configuration

- WDS-500-MP-R-SPL
- Draw-wire sensor (modified special design)

Ambient conditions

- Temperature range:
 - rapid temp. drop from + 60 °C down to -250 °C
- Resistant to high acceleration forces
- Resistant to electromagnetic radiation
- To be able to function in a zero gravity environment
- To be able to withstand a rapid drop in air pressure and operate in a vacuum

Reasons for choosing the system

- High Linearity
- Compact, light and reliable construction in combination with large measuring range
- Tested and proven high reliability

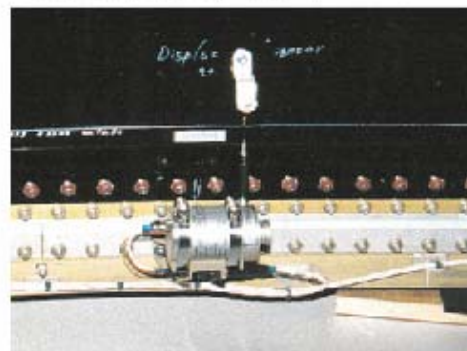

Pic: Daimler Benz Aerospace Domier GmbH, Friedrichshafen

MICRO-EPSILON

Koenigbacher Str. 15
 94496 Ottenburg / Germany

Tel.: 0 85 42/1 68 0
 Fax: 0 85 42/1 68 90

info@micro-epsilon.com
 www.micro-epsilon.com

A member of micro-epsilon group.
 Certified DIN EN ISO 9001 : 2000
 Modifications reserved 19781043

