



Publication Year	2023
Acceptance in OA	2023-08-29T14:05:26Z
Title	The AGILE real-time analysis software system to detect short-transient events in the multi-messenger era
Authors	PARMIGGIANI, Nicolo', BULGARELLI, ANDREA, URSI, Alessandro, Addis, A., Baroncelli, L., FIORETTI, Valentina, Di Piano, A., Panebianco, G., TAVANI, Marco, PITTORI, Carlotta, VERRECCHIA, Francesco, Beneventano, D.
Publisher's version (DOI)	10.1016/j.ascom.2023.100726
Handle	http://hdl.handle.net/20.500.12386/34361
Journal	ASTRONOMY AND COMPUTING
Volume	44

The AGILE real-time analysis software system to detect short-transient events in the multi-messenger era

N. Parmiggiani^a, A. Bulgarelli^a, A. Ursi^b, A. Addis^a, L. Baroncelli^a, V. Fioretti^a, A. Di Piano^{c,a}, G. Panebianco^{d,a}, M. Tavani^b, C. Pittori^{e,f}, F. Verrecchia^{e,f} and D. Beneventano^c

^aINAF/OAS Bologna, Via P. Gobetti 93/3, I-40129 Bologna, Italy.

^bINAF/IAPS Roma, via del Fosso del Cavaliere 100, I-00133 Roma, Italy.

^cUniversità degli Studi di Modena e Reggio Emilia, DIF - Via Pietro Vivarelli 10, I-41125 Modena, Italy.

^dDepartment of Physics and Astronomy, University of Bologna, Via Gobetti 93/2, 40129, Bologna, Italy.

^eINAF/OAR Roma, Via di Frascati 33, I-00078 Monte Porzio Catone, Italy.

^fASI Space Science Data Center (SSDC), Via del Politecnico snc, I-00133 Roma, Italy.

ARTICLE INFO

Keywords:

real-time analysis pipeline
gamma-ray astronomy
multi-messenger astronomy
gamma-ray burst
gravitational waves

ABSTRACT

AGILE is a space mission launched in 2007 to study X-ray and gamma-ray phenomena through data acquired by different instruments on board the satellite. In the multi-messenger era, the fast detection of transient sources is one of the main goals of space and ground-based gamma-ray observatories. When an observatory detects a transient event, it usually sends science alerts to other facilities through networks such as the General Coordinates Network (GCN), enabling follow-up observations. To achieve this task, real-time analysis (RTA) pipelines are required. This manuscript presents the RTA system developed for the AGILE space mission to detect transient sources on timescales from seconds to one hour. Two types of pipelines are presented. One pipeline executes automated analyses as soon as data are available, sharing the detection of sources with the community; more than 90 automated notices have been sent to the GCN since May 2019. The other pipeline reacts to external science alerts from neutrinos, gravitational waves (GW), etc., to search for electromagnetic counterparts in the AGILE data. The AGILE Team can visualize the results of these analyses using a web platform. The pipelines hereby presented can be a starting point for the development of RTA systems of the next generation of space-based gamma-ray observatories.

1. Introduction

AGILE (Astrorivelatore Gamma ad Immagini LEggero - Light Imager for Gamma-Ray Astrophysics) is a scientific mission of the Italian Space Agency (ASI) launched on April 23, 2007. The AGILE payload (Tavani and et. al. (2009)) consists of the Silicon Tracker (ST), the SuperAGILE X-ray detector, the Mini-Calorimeter (MCAL), and an AntiCoincidence System (ACS). The combination of ST, MCAL, and ACS constitutes the Gamma-Ray Imaging Detector (GRID).

The data acquired by AGILE are downlinked to the ASI ground station (Malindi, Kenya). Depending on the ground station availability schedule, the downlink may happen at each orbit (about 90 minutes) or less. The raw data acquired during the downlink (called contact) contains the scientific telemetry, housekeeping, and ratemeters of all scientific instruments. The scientific telemetry contains information acquired by the detectors related to γ -rays and can be used to obtain scientific results such as the flux or the sky position of a γ -ray source. The housekeeping, or auxiliary data (AUX), is related to the monitoring of the on-board instruments' status, and also to the information about the satellite itself, such as orbital and attitude data. Part of the housekeeping data is

required to perform the scientific analysis. Finally, the data acquired by all AGILE detectors are continuously recorded in telemetry as ratemeters (RM), with 0.512 s (SA) and 1.024 s (GRID, MCAL, and AC) time resolution. The RM provide a continuous monitoring of the X- and γ -ray background but can also detect high-energy transients such as Gamma-Ray Bursts (GRB), soft gamma repeaters, and solar flares. The RM can be generally used as independent (non-imaging) detectors. RMs are used as a backup detection system or to cross-validate the results of the scientific telemetry. After the downlink, the data are sent to Telespazio, Fucino (Italy) through a dedicated ASINet network, and finally to the ASI Space Science Data Center¹ (SSDC) where the AGILE Science Operation Center (SOC) is located (Pittori and The AGILE-SSDC Team, 2019).

The AGILE SOC archives and processes raw data through the AGILE Telemetry Preprocessing System (TMPPS) and the reconstruction pipeline (RECO). The output of these two systems is archived and distributed to the National Institute for Astrophysics (INAF/OAS) in Bologna (Italy), where the AGILE Real-Time Analysis (RTA) described in this paper runs. The AGILE data flow (Figure 1) and the reconstruction software systems are described in detail in Bulgarelli and et. al. (2014); Bulgarelli (2019).

In multi-wavelength (MWL) and multi-messenger (MM) astronomy (Meszaros et al., 2019), sharing science alerts with the scientific community enables studies of the same

ORCID(s): 0000-0002-4535-5329 (N. Parmiggiani);
0000-0001-6347-0649 (A. Bulgarelli); 0000-0002-7253-9721 (A. Ursi);
0000-0002-0886-8045 (A. Addis); 0000-0002-9215-4992 (L. Baroncelli);
0000-0002-6082-5384 (V. Fioretti); 0000-0002-9894-7491 (A.D. Piano);
0000-0002-3410-8613 (G. Panebianco); 0000-0003-2893-1459 (M. Tavani);
0000-0001-6661-9779 (C. Pittori); 0000-0003-3455-5082 (F. Verrecchia);
0000-0001-6616-1753 (D. Beneventano)

¹<https://www.ssdsc.asi.it>

AGILE Satellite

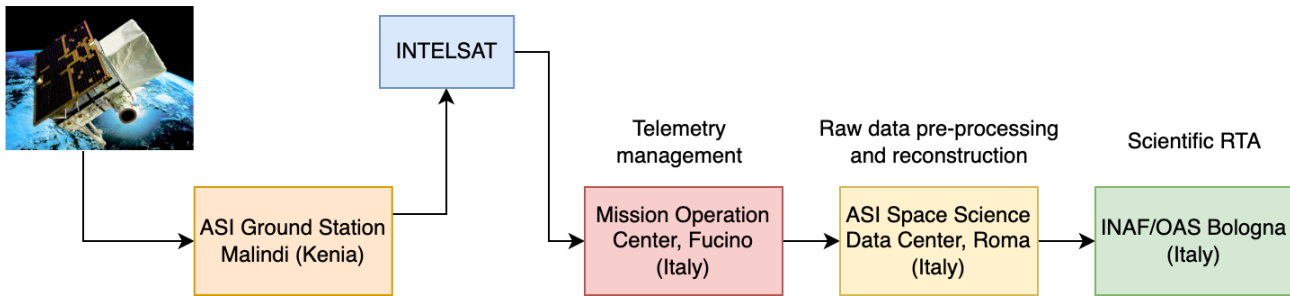

Figure 1: Schema of the AGILE data flow, from the satellite to the scientific pipelines.

physical phenomena through different "messengers" (neutrinos, gravitational waves, and electromagnetic waves) and at different wavelengths. Science alerts are generally shared through communication networks such as the General Coordinates Network² (GCN); the GCN distributes two types of information: (i) circulars written by and for humans and (ii) machine-readable notices.

Many astronomical facilities develop a real-time analysis (RTA) system to perform automated analyses of their data or react to external science alerts, an essential capability in the context of the MWL/MM era. Section 2 of Parmiggiani et al. (2022) describes an overview of the RTA systems developed by several facilities. To help in the development of RTA pipelines for γ -ray projects, we designed the RTApipe framework (Parmiggiani et al., 2022), which satisfies the demanding requirements of the MM astronomy context. In this manuscript, we describe the updated version of the AGILE RTA system (Bulgarelli, 2019), developed using the RTApipe framework, which performs prompt analyses on the data acquired by the satellite.

The RTA pipelines developed for AGILE aims to satisfy three main science cases:

1. The AGILE RTA shall react to external science alerts received through the GCN network and perform scientific analyses searching for counterparts. The follow-up of science alerts (e.g., GRB, gravitational waves, or cosmic neutrino events) shall be rapidly executed in order to promptly share AGILE detections with the scientific community.
2. The AGILE RTA shall execute a blind search as soon as new data are acquired, searching for transient events over different time scales such as GRBs. If the RTA system detects a transient event, it sends a notification to the AGILE Team and eventually a communication to the scientific community.
3. The AGILE/MCAL instrument has an on-board trigger logic that acquires and analyzes data only when certain threshold conditions are satisfied. The data acquired on board shall be processed by the RTA system, searching for possible detection of transient events. The on-board triggers drive the data acquisition. For

this reason, the analysis of the on-ground pipeline uses data already classified as containing a possible burst and shall validate and improve the statistical evaluation of the transient events to reduce the false positives. This refined analysis allows the RTA system to automatically send science alert notices to the scientific community.

To monitor the results obtained with the RTA pipelines and to perform the follow-up of external science alerts, the AGILE Team is organized with shifts that cover 24/7. The Burst Advocate, in charge of this monitoring, must validate the results obtained with automated software before sharing them with the community. The GCN notices received by other facilities are cross-checked with AGILE results by the Burst Advocate.

Thanks to its RTA pipeline, AGILE contributed to MM and MWL observations by collecting several significant results (Section 4.3) and promptly reacting to science alerts, with a special focus on gravitational wave events.

The manuscript is organized as follows. The architecture of the AGILE RTA system is illustrated in Section 2. The pipelines developed for AGILE and the main results obtained are described in sections 3 and 4. Section 5 presents the AGILE web Control Room. Section 6 describes the AGILE RTA deployment and backup services. In Section 7 we describe how we use Deep Learning technologies to develop analysis tools that can be integrated in the AGILE RTA pipelines. Finally, in Section 8 conclusions are drawn.

2. AGILE Real-Time Analysis architecture

Figure 2 shows the AGILE RTA software architecture. The AGILE RTA has three sources of inputs: (i) pre-processed and reconstructed AGILE data received from SSC (see Section 1) and saved in the Local Data Archive (LDA); (ii) external science alerts from the GCN; and (iii) internal science alerts about GRBs detected in the AGILE-MCAL data.

The Science Alerts Receiver (SAR) manages external science alerts, received as VOEvent notices from the GCN, as well as internal science alerts. We implemented the SAR

²<https://gcn.nasa.gov>

AGILE real-time analysis

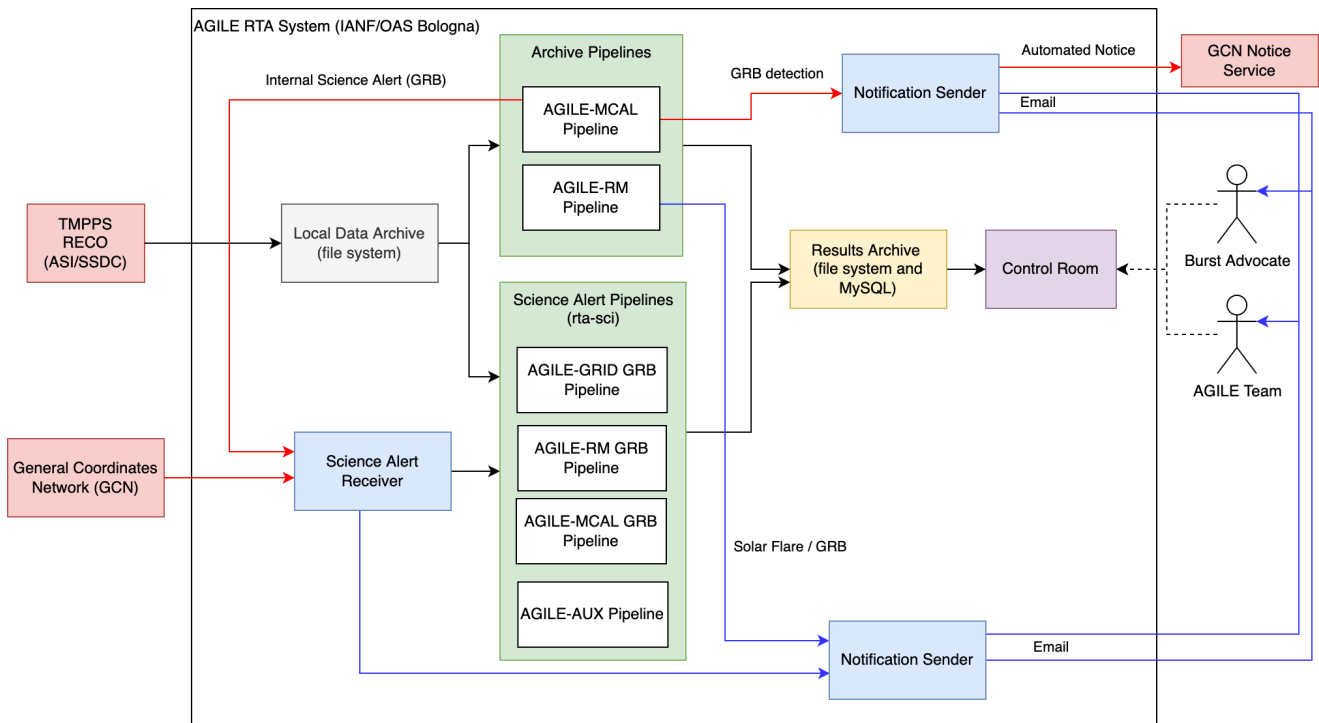

Figure 2: High-level architecture of the AGILE real-time analysis software system. In this plot we show two notification senders to avoid complex arrow paths.

using the GCN Classic over Kafka³ service. Kafka is an open-source distributed event streaming platform. This GCN service distributes VOEvents related to science alerts using Kafka. The VOEvent data format is a standard used to describe celestial transient events in a machine-readable format.

The RTA pipelines satisfying the science cases of Section 1 can be further divided into two categories: the Science Alert Pipelines (SAP) and the Archive Pipelines (AP).

The SAP satisfy the first science case, and are described in Section 3. They react to science alerts received from the GCN network and start a list of analyses to detect counterparts. The SAP is composed of four pipelines that analyze the data types described in Section 1:

1. The AGILE-GRID GRB pipeline generates plots showing the AGILE-GRID data in several time windows centered on the received science alert's trigger time. In addition, this pipeline executes analyses with the Li&Ma method (Li and Ma, 1983) centered on the alert's sky coordinates.
2. The AGILE-MCAL GRB pipeline uses the AGILE-MCAL data to generate plots over different time windows centered on the science alert's trigger time.
3. The AGILE-RM GRB pipeline generates plots using the RM data collected by the AGILE detectors, such as MCAL, SA, GRID, and ACS. These plots show a time series, e.g., the number of photons or particles detected per second. The AGILE Team can use these

plots to search for indications of count peaks over the background and then verify the burst's significance with the results of other pipelines.

4. The AGILE-AUX pipeline generates plots using auxiliary data, showing the AGILE detector status and the sky region visibility at trigger time, taking into account Earth occultation and Sun pointing constraints.

The AP, described in Section 4, covers the second and third science cases by analyzing data from the MCAL detector and RMs to detect GRBs and solar flares. These pipelines are not triggered by external science alerts but rather perform a blind search of transient events analyzing all the AGILE data acquired. The AGILE RTA system implements two AP pipelines:

1. The AGILE-MCAL pipeline analyzes data acquired by the AGILE-MCAL detector and performs a blind search of transient events such as GRBs. This pipeline can automatically share GRB detection with the scientific community through the emission of AGILE MCAL Notice Alerts⁴.
2. The AGILE-RM pipeline analyzes the RM data searching for transient events such as GRBs and solar flares. When the pipeline detects a candidate transient event, it sends an email to the AGILE Team for further investigation.

The Notification Sender (NS) is the software component that sends emails to the AGILE Team and the Burst Advocate when the SAR receives a new science alert, or when

³<https://kafka.apache.org>

⁴https://gcn.gsfc.nasa.gov/agile_mcal.html

the AGILE RTA detects a transient event (such as candidate GRB or solar flare). In addition, the NS sends an automated notice to the GCN when the AGILE-MCAL pipeline detects a GRB.

The scientific results produced by both pipelines are stored in the Result Archive (the file system and a MySQL database). The AGILE Team and the Burst Advocate can visualize the results using the password-protected web Graphical User Interface (GUI), called Control Room, which is described in Section 5.

We developed the RTA pipelines using the RTApipe and by integrating different science tools and software tasks developed by the AGILE Team and SSCD personnel. The RTApipe main features are:

1. The software services and dependencies of the pipelines are installed inside a Singularity⁵ container. The system is flexible enough to use existing services hosted outside the container, if required. The container guarantees the reproducibility of the environment and can be used to insert the pipeline into a continuous integration system;
2. The pipelines submit analyses to the Slurm⁶ workload manager. With this service, it is possible to execute several analyses in parallel and manage priority between them;
3. The pipelines can be interfaced with different science tools in different programming languages and can perform different analyses for different types of targets and science alerts (e.g., GW or GRB);
4. The system's flexibility allows the configuration of several workflows with the same science tools (e.g., light curves with different timescales);
5. Slurm logs the status of the processes in a database, information which can be used to monitor the system in real time.

More detail about the RTApipe framework can be found in Parmiggiani et al. (2022).

3. Science Alert Pipeline

The SAP (also called rta-sci) responds to internal or external science alerts (e.g., GRBs or GWs) and performs automated scientific analyses to find a candidate counterpart and inform the AGILE Team. This pipeline aims to cover the first science case described in Section 1. The type of scientific analysis depends on the type of scientific target and on the timescale of the event. The AGILE-MCAL pipeline can generate internal science alerts when a GRB is detected during the analysis for the second and third science cases. These alerts are then injected into the SAP pipeline as internal science alerts, triggering the system to search for counterparts in other AGILE detectors' data.

The architecture of the SAP pipeline is shown in Figure 3. It executes four different analyses using relative Python

wrappers, which are interfaces between the science tools and the framework: the AGILE-GRID wrapper, the AGILE-MCAL wrapper, the AGILE-RM wrapper, and the AGILE-AUX wrapper. The SAP receives as input an external science alert from the GCN or an internal science alert from the AGILE-MCAL pipeline, and then it checks if the LDA contains the data required in input for the analysis. If not, it waits until the data is received. When the data becomes available, the system automatically executes a list of pre-configured analyses, using the science tools developed by the AGILE Team for the different AGILE detectors.

The pipeline performs more than 100 analyses, using 20 different science tools for each science alert. In fact, the SAP manages several types of science alerts (e.g., GW, GRB, and cosmic neutrinos) that can have different time scales (e.g., short GRBs and long GRBs) or that can be detected from different AGILE instruments. For this reason, the system automatically executes a list of analyses to cover many possible scenarios, analyzing the data of all AGILE detectors. Analyses can be customized for each science alert type (and are managed through Slurm to exploit parallelization on the available computing power. Results are generated in a short time (a few minutes) from the alert or data arrival. Obtaining fast results is mandatory during follow-ups of science alerts.

The results of the pipelines are stored inside the Results Archive; the AGILE Team and the Burst Advocate can visualize them through the Control Room (5).

The pipeline performs two categories of analysis: the prompt (Section 3.1) and the full analysis (Section 3.2). The prompt analysis aims to analyze the AGILE data near the trigger time of the science alert. If AGILE instruments have visibility during the first few seconds of the transient event, these pipelines can provide insightful results. Even if there is no visibility at trigger time, the AGILE team can visualize the results of the full analysis performed on longer timescales, from 1000 seconds before the trigger until 1000 seconds after.

3.1. Prompt Results

Prompt analyses use time windows of different lengths centered on the transient event trigger time and search for a counterpart of the science alert.

The AGILE-AUX pipeline generates plots showing the visibility of the alert (Figure 4) with respect to all AGILE detectors. These plots are the first results that the Burst Advocate can visualize during a follow-up. Indeed, each instrument has a field of view that, combined with the satellite pointing direction, the Earth occultation, and the Sun pointing constraints, creates a visibility region. One of these plots is produced with prevision information and does not require data coverage in the LDA. For this reason, it is immediately available after receiving the science alerts, although providing less information (e.g., there is no information about the detectors' fields of view). When the data related to the science alert's trigger time arrives in the LDA, a new visibility plot is generated adding information about

⁵<https://sylabs.io/docs/>

⁶<https://slurm.schedmd.com>

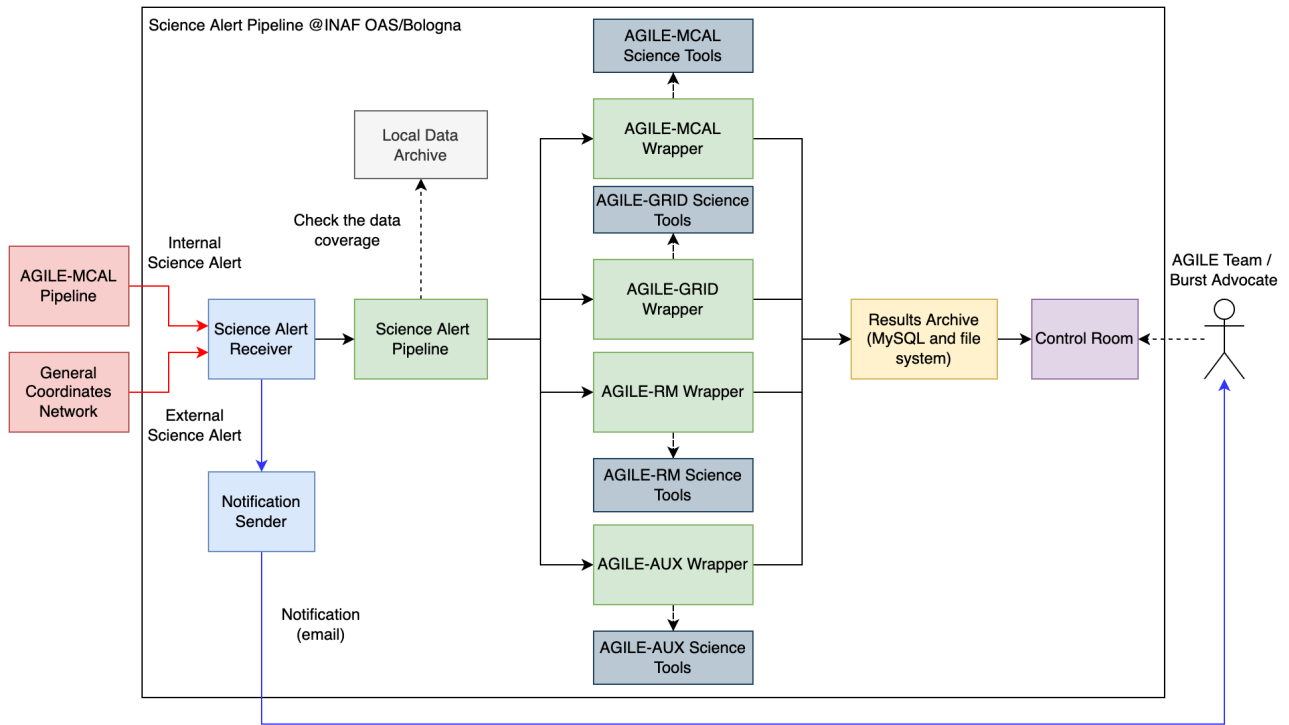

Figure 3: High-level schema of the AGILE RTA Science Alert Pipeline. This pipeline reacts to science alerts received by the GCN or to internal science alerts. It notifies the AGILE Team under pre-defined conditions and, in case of data coverage, executes several analyses searching for a transient's counterpart. Results are stored in the file system and in a MySQL database, and the AGILE Team can visualize them using a web GUI.

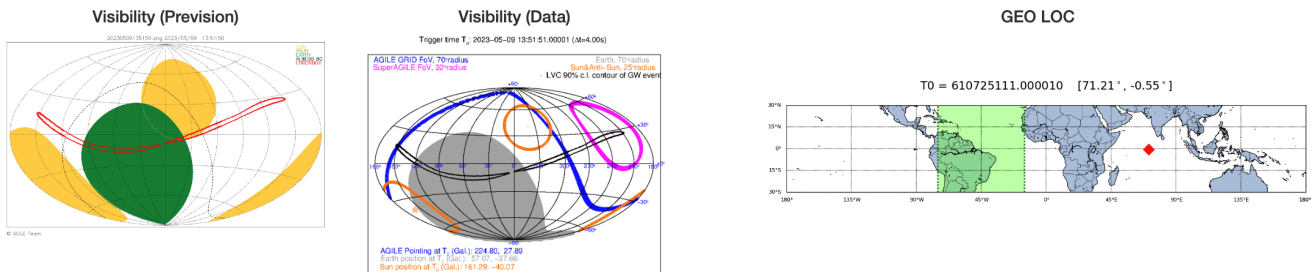

Figure 4: The left plot shows a prevision of the Earth occultation region (green) and of the Sun-antiSun exclusion region due to solar panel pointing constraints (yellow) with respect to the region of interest (red) at the trigger time. The central plot shows the AGILE instruments' actual visibility of the science alert localization region (black) and is generated when the pipeline receives the AGILE data. The right plot shows the SAA region (green) and the AGILE sub-satellite Earth latitude and longitude at trigger time (red diamond).

the detectors. The last plot of figure 4 shows the AGILE sub-satellite Earth latitude and longitude at trigger time. This map is used to check if the satellite is crossing the South Atlantic Anomaly, where the instruments are put in IDLE to avoid the acquisition of data with high background due to the massive presence of high-energy charged particles.

The AGILE-MCAL GRB pipeline produces several plots (Figure 5) showing the AGILE-MCAL data triggered on board. Each plot is composed of several light curves in different energy ranges and within different temporal windows centered at the T_0 (± 5 , $\pm 10 \pm 100$, ± 1000 seconds). These plots show if a GRB signature (an increase in the count rate) is present within the data. Moreover, the different time

windows allow to better visualize phenomena occurring on different timescales.

The AGILE-GRID GRB pipeline generates count maps, exposure maps, and upper limit maps. In addition, it performs a blind search analysis, in the energy range 50 MeV-10 GeV, within the localization region of the science alert, using the Li&Ma method.

The external science alerts typically come with a localization region, which the AGILE-GRID GRB pipeline takes as input to spatially constrain the analysis. If the localization region is larger than a pre-defined area, the pipeline executes a blind search through multiple analyses on different sky positions to cover the sky region.

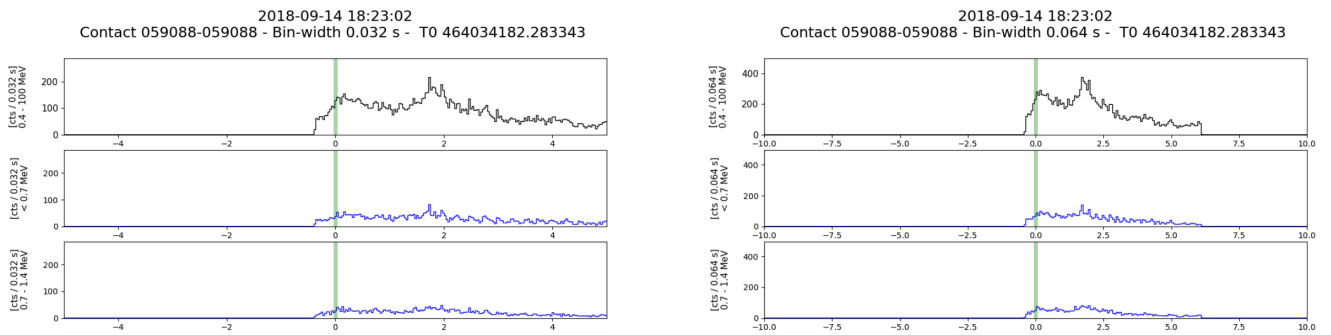

Figure 5: Light curves showing the GRB180914B at different energy ranges (only the first three bands for space reasons), using different time windows centered at the trigger time. These plots are used by the Burst Advocate to check if a GRB is present in the AGILE-MCAL data.

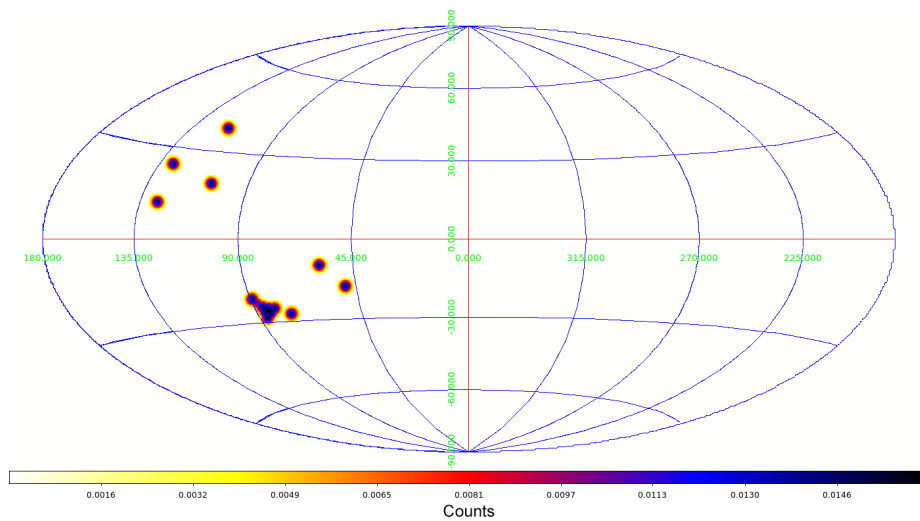

Figure 6: AGILE-GRID count map showing the GRB180914B in Galactic coordinates and Hammer-Aitoff projection, obtained using 10 seconds of integration time centered at the science alert's trigger time. The AGILE-MCAL pipeline detected the GRB and triggered the analysis. The AGILE-MCAL instrument cannot locate the GRB, so the map does not contain a localization error region. The GRB is detected with a spatial blind search (Figure 8).

These results (Figures 6-7-8) are an overview of the AGILE-GRID data. They can be used to detect a candidate GRB or to evaluate upper limits in the sky region of a science alert. Following the same design of the MCAL pipeline's results, plots for different time windows (± 2 , ± 5 , ± 10 , ± 100 seconds) are delivered.

The AGILE-RM GRB pipeline generates plots (Figure 9) in support of the Burst Advocate, showing the RM of all detectors on board the AGILE satellite. The RMs provide a continuous stream of data acquired by the AGILE main detectors, which can be used to integrate the results and carry out multi-wavelength analysis of the detected transients. It is possible that, under certain satellite configurations, data are not acquired from some of the payload detectors, and the only way to follow up a transient is via the RMs' results.

3.2. Full Results

Sometimes AGILE detectors have no visibility coverage of the transient event at the trigger time, due to observational constraints (i.e., Earth and South Atlantic Anomaly) or due

to the transient duration itself. For this reason, we implemented another category of analysis, called full analysis, which executes the analysis over a longer time window (± 1000 seconds) using integration steps of 100 seconds. This analysis allows the Burst Advocate to check the results as soon as the transient source is covered by the visibility of the AGILE detectors.

The full analysis pipeline executes several analyses with the AGILE-GRID, AGILE-MCAL, and AGILE-AUX wrappers for each time window of 100 seconds. Thus, at each time interval the analyses generate a set of plots: GRID counts and exposure maps, visibility plots, and MCAL light curves. The Burst Advocate can visualize the results of the data acquired by AGILE detectors before and after the trigger time of the science alert.

4. AGILE Archive pipelines

The AP execute analyses as soon as data from AGILE-MCAL and the RM are received, searching for transient

AGILE real-time analysis

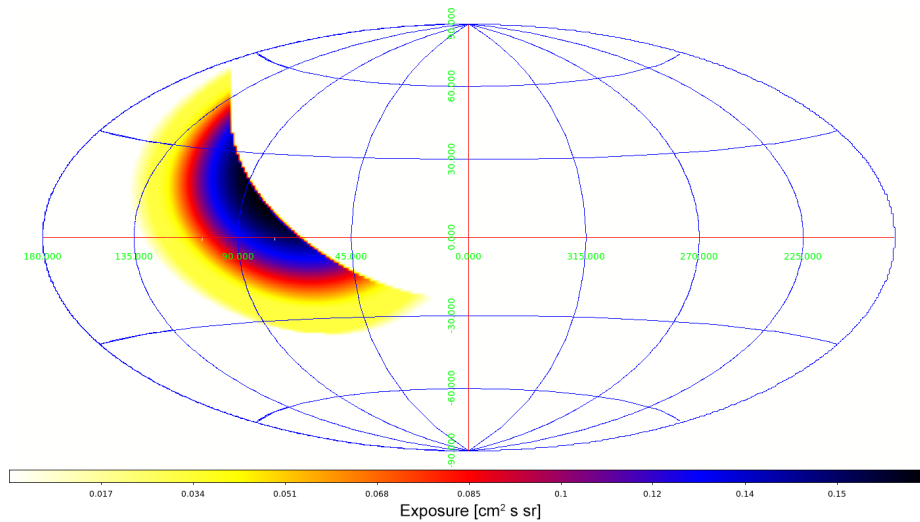

Figure 7: AGILE-GRID exposure map in Galactic coordinates and Hammer-Aitoff projection, computed using 10 seconds of integration time centered at the science alert's trigger time for the GRB180914B.

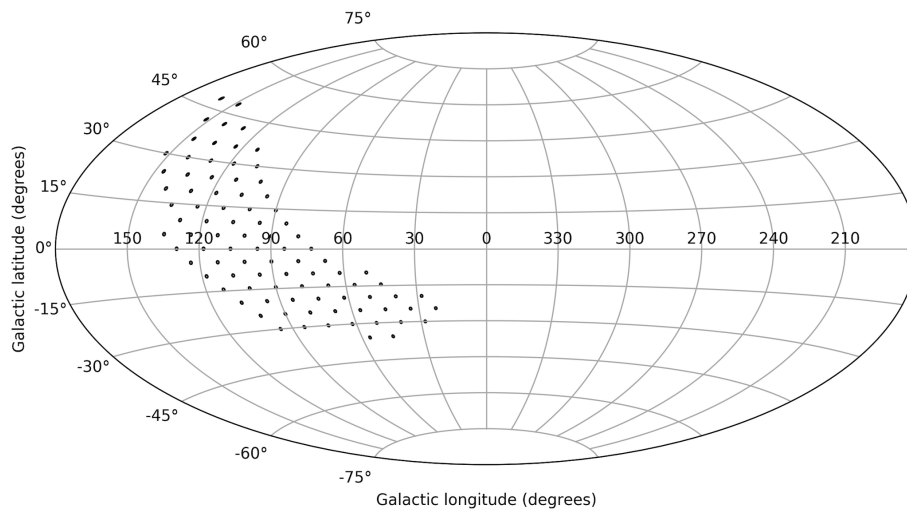

Figure 8: Blind search for the GRB180914B, triggered by an internal science alert from the AGILE-MCAL pipeline. The analyses are performed with the Li&Ma method on a grid of coordinates within the sky region of the science alert where AGILE-GRID has exposure (Figure 7).

events such as GRBs, Terrestrial Gamma-ray Flashes (TGF), and solar flares. We developed these pipelines to cover the second and third science cases described in Section 1.

Figure 10 shows the software architecture of the AP. When new data arrive from the ASI/SSDC data center to the INAF/OAS Bologna LDA, two separate pipelines are executed: the AGILE-MCAL pipeline (Section 4.1) and the AGILE-RM pipeline (Section 4.2). These pipelines are interfaced with the science tools developed to analyze a specific data type using Python wrappers: AGILE-MCAL wrapper and AGILE-RM wrapper.

4.1. AGILE-MCAL pipeline

The AGILE-MCAL pipeline performs the detection of GRBs and TGFs. TGFs are intense and brief γ -ray emissions associated with lightning and thunderstorm activity. The

TGF detection algorithm acts on submillisecond timescales, requiring at least eight counts occurring within a 300 μ s time window (Marisaldi et al., 2010). In fact, these events are detected as millisecond timescale bursts of gamma rays rather than one-time rays that come from the Earth and have a spectral hardness higher than that of cosmic GRBs.

The AGILE Team implemented an algorithm to detect GRBs independently from the MCAL on-board trigger logic. It performs an offline blind search on several timescales (16, 32, 64, and 128 ms). The algorithm independently evaluates the background level for each timescale of the analysis and discards events that can be confidently classified as statistical fluctuations of the background. When more than one time window has a count rate that exceeds a pre-defined threshold, the algorithm identifies that event as a GRB. In particular, for each timescale, we require either

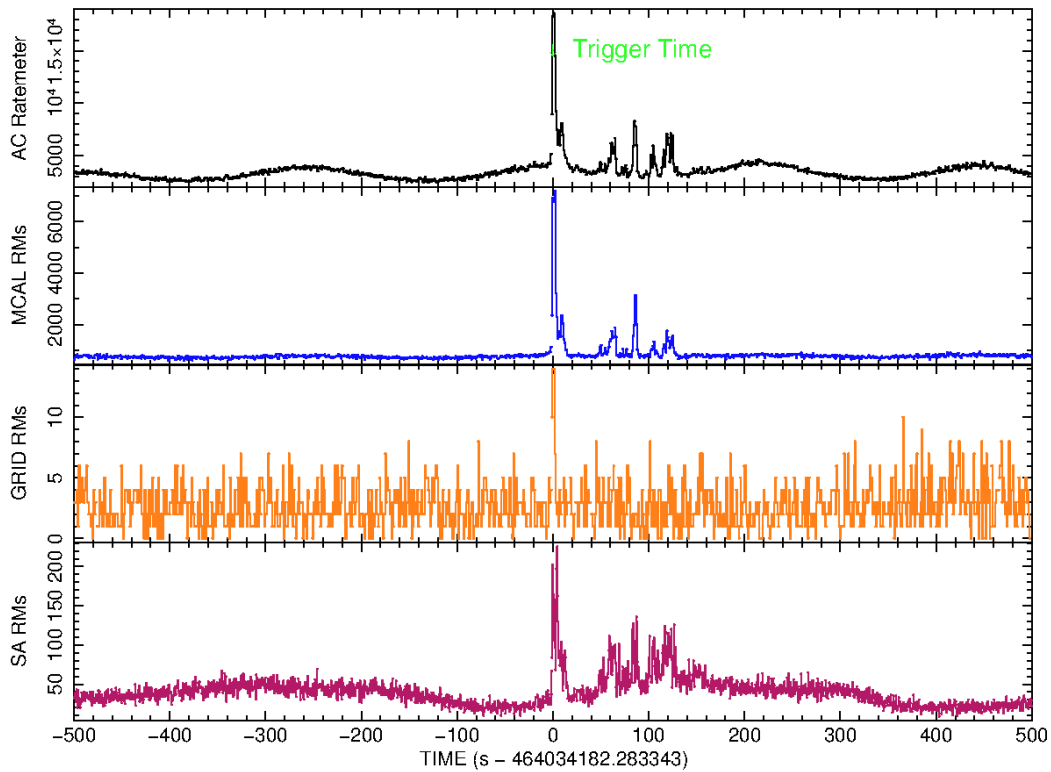

Figure 9: Results of the AGILE-RM GRB pipeline for the GRB180914B. The plot shows the light curves for the RM of the AC system and of the AGILE detectors.

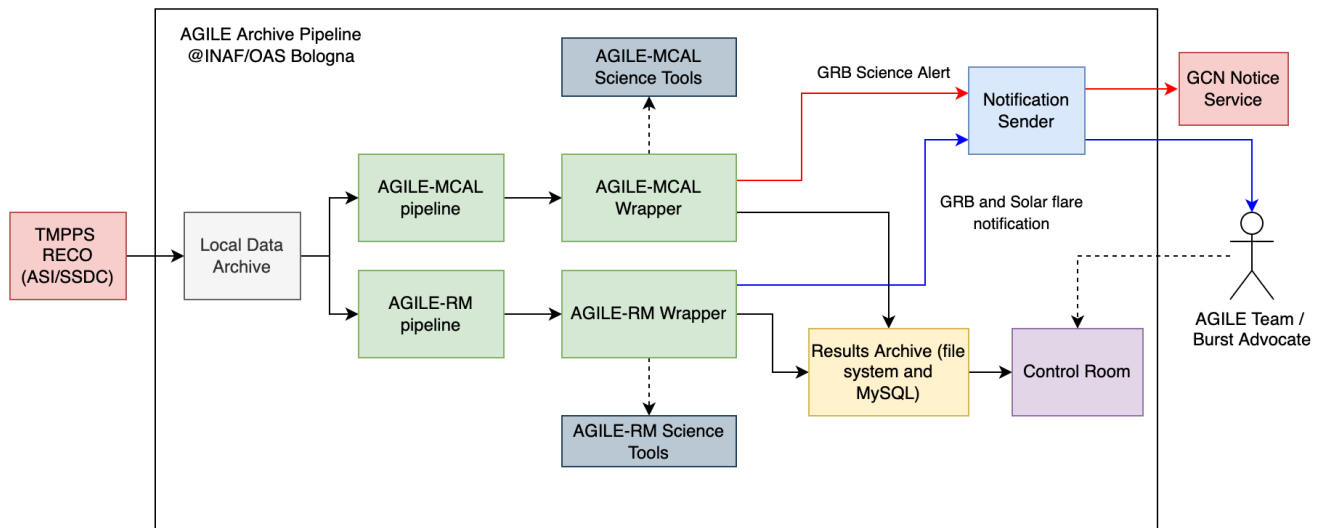

Figure 10: High-level schema of the AP. These pipelines are triggered by the arrival of new data from the ASI/SSDC Science Operation Center (Roma). The pipelines execute analysis to detect transient events (GRBs, TGFs, and solar flares) using the AGILE-MCAL and RM data. When a transient event is detected, the pipelines send an email to the AGILE Team. If the AGILE-MCAL pipeline detects a GRB, it automatically sends a notice to the GCN. The results are stored in the file system and in a MySQL database. The AGILE Team can visualize the results using the Control Room.

having at least three consecutive time windows exceeding a 3σ confidence level or five consecutive time windows exceeding 1σ sigma confidence level. These thresholds, imposed on different exposures, allow the revealing of both short and long GRBs. Either one or both of these detection

requirements can identify a single event. Information about the source (e.g., count rate, the statistical significance of the detection, and event trigger time) is sent to the GCN with a notice to share the results with the scientific community. Although the AGILE-MCAL detector cannot localize the

2022-06-24 02:58:39
 Contact 078864 Trigger 2
 Bin 0.032 s - T0 583124319.694236 - Int. Time 0.192 - S/N 15.22 σ
 Logic time scales: [", ", '16ms', ", '256ms', ", "]

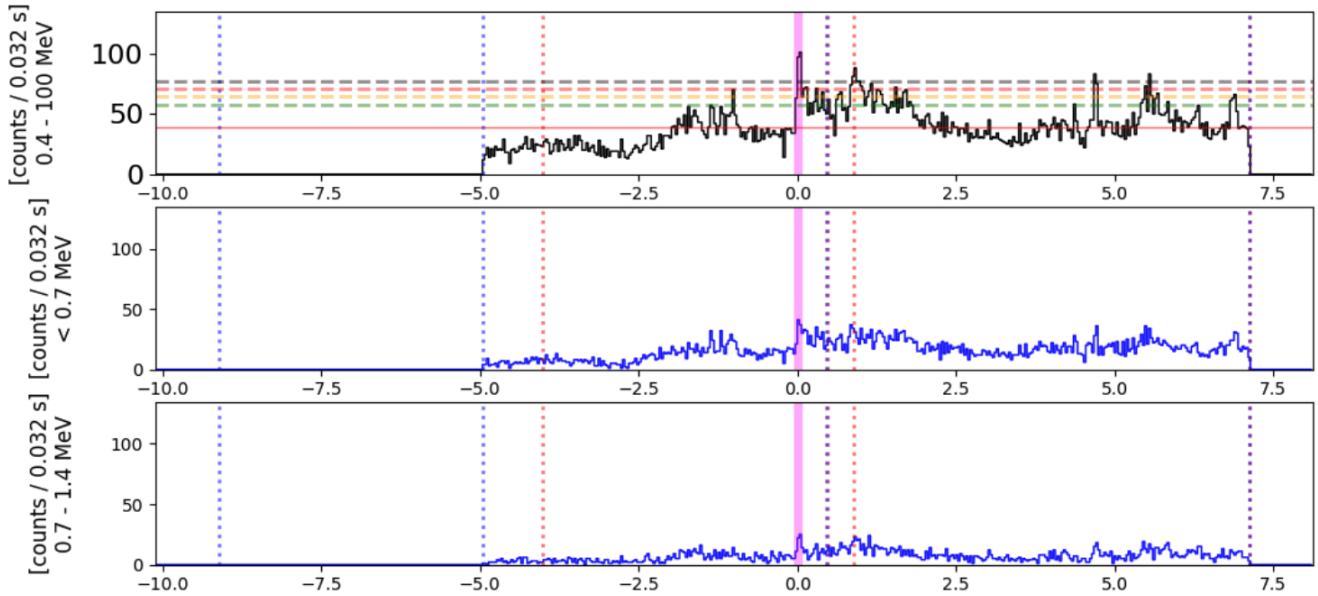

Figure 11: AGILE-MCAL light curve of the GRB220624A at different energy ranges (only the first three bands for space reasons). The dashed horizontal lines represent the different significance levels of the signal. The vertical purple line indicates the peak of the GRB. The vertical dotted lines indicate the on-board trigger logic with the time start and time end of data acquired around the trigger time and the pre/post burst time windows.

GRB, other facilities can follow up on the event and search for a time coincidence with the provided trigger time.

The AGILE-MCAL pipeline has a dedicated web GUI, accessible from the Control Room, that shows on the home page a table of all the detected GRBs. The table reports general information for each GRB (e.g., the significance of the event, the signal integrated counts, etc.). It is possible to open a detailed web page for each GRB to visualize light curves (Fig. 11) at different energy ranges.

The AGILE-MCAL GUI has a section dedicated to the TGFs detected by the pipeline. The TGFs are listed in a table that shows information about them, and through a dedicated web page, the AGILE Team can access more detailed results of a specific TGF (Figure 12). A two-panel plot displays the TGF light curve and the energy of each detected photon. In addition, a plot showing the AGILE sub-satellite Earth latitude and longitude (red dot) is provided.

4.2. AGILE ratemeters pipeline

We developed an RTA pipeline to analyze the RM data acquired by all detectors on board the AGILE satellite (GRID, SA, MCAL, and AC) to detect GRBs. Recently, we updated the pipeline with an algorithm to detect solar flares in the RM data of the fourth ACS panel, which is continuously pointed toward the Sun. The algorithm requires to have at least 60 consecutive 1.024 s time bins (i.e., 1 min), exceeding a threshold level of 3σ above the background rate. This requirement is imposed to reject all shorter-duration

events, such as singular spikes due to high-energy particles, as well as the majority of GRBs. The analysis of RM is important because these data are almost always acquired even when the scientific telemetry of the AGILE detectors is not fully available due to excessive memory usage on board.

The AGILE-RM pipeline has a dedicated web GUI, accessible from the Control Room, to allow the visualization of the results aggregated by contact number. Figure 13 shows the RM' time series of the detectors on board AGILE, split into batches of 550 seconds. The original time series is shown on the left, and the detrended light curve is shown on the right. The latter have been processed with a detrending algorithm that applies Fast Fourier Transforms (FFTs) to remove the effects of the background oscillations, due to the orbital phase and the satellite spinning modulation.

The Burst Advocates monitor this pipeline's results to check for candidate GRBs. An automated algorithm helps the process by highlighting the candidate bursts inside the plots with colored boxes, based on pre-defined thresholds. The GRB detection algorithm works in two modes. The first requires at least one bin exhibiting a strong signal in the RM of a single detector (i.e., SuperAGILE, MCAL, or ACS top panel). Specifically, it should have an independent significance of 5σ in the SuperAGILE RM, 5σ in the MCAL RM, and 7σ in the ACS top panel RM (this last threshold is slightly higher due to the relatively higher background rate of the detector). Since the ACS top panel is part of the

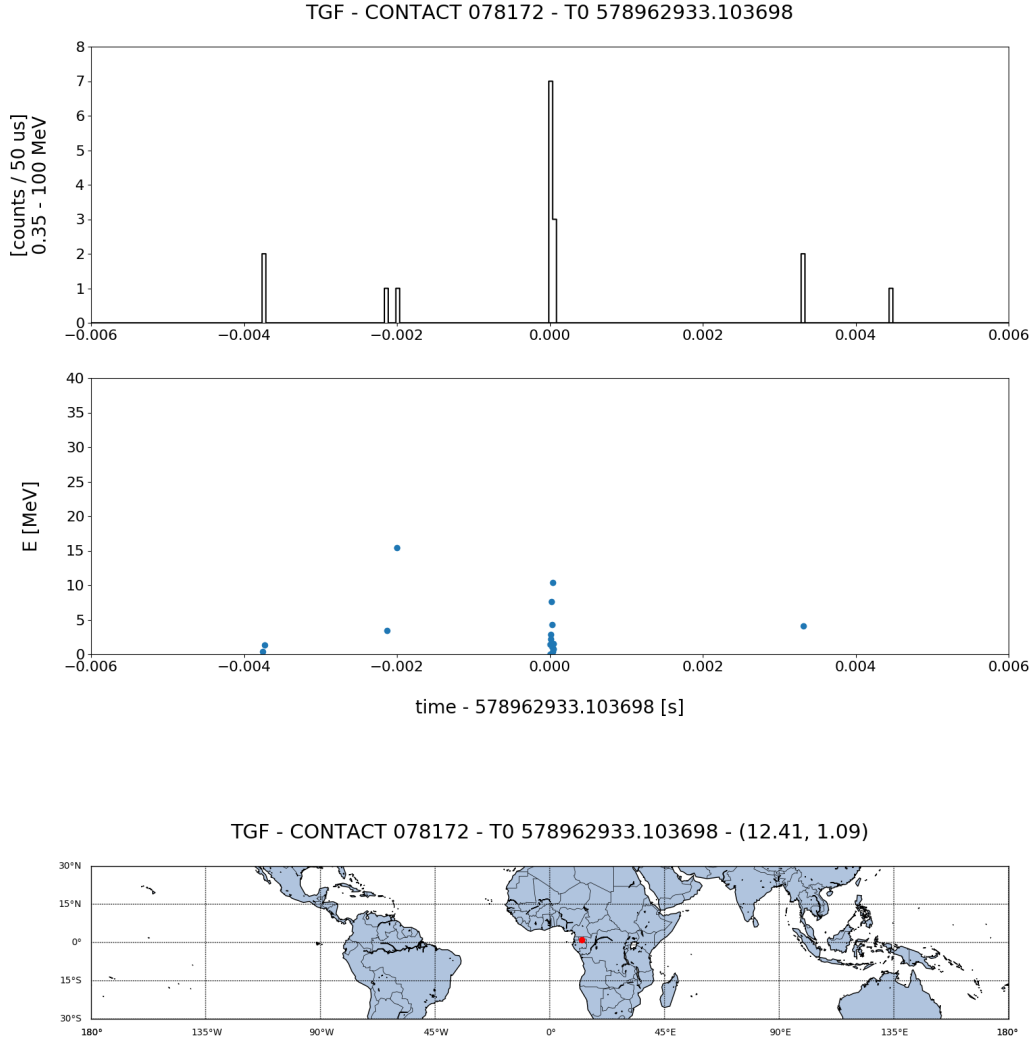

Figure 12: The first two panels show the light curve and photon scatter plot of a TGF detected by the AGILE/MCAL. The bottom panel represents the earth map with the position of the AGILE sub-satellite Earth latitude and longitude (red dot) during the detection of the TGF.

system that aims to shield the inner detectors from the high-energy charged particles, a higher threshold is imposed on its RM. The second mode requires lower-intensity signals that occur simultaneously (i.e., within the same time bin) in all detectors' RM (i.e., SuperAGILE, MCAL, and AC Top). Exploiting the temporal coincidence, a signal with an overall 5σ confidence level (5.7×10^{-7}) can be achieved by requiring only 3.5σ (4.6×10^{-4}) signals occurring simultaneously in all three detectors.

4.3. Results obtained with the AGILE RTA pipelines

Since May 2019, the AGILE/MCAL pipeline has been enabled to automatically send notices to the GCN network after a GRB detection. At the time of writing, it sent more

than 90 notices⁷ containing information and light curves of the detected burst.

In addition, the AGILE Team sent more than 200 circulars to the GCN network, about the results of the RTA pipelines for the follow-up of transient events (in particular during the third LIGO/Virgo observing campaign), and several ATels communications.

The AGILE Team also published several articles in which part of the results was obtained using the RTA pipelines presented in this contribution, in support of the final analysis (Ursi et al., 2022; Tavani et al., 2021; Ursi et al., 2020; Casentini et al., 2020; Verrecchia et al., 2019; Lucarelli et al., 2019).

⁷https://gcn.gsfc.nasa.gov/agile_mcal.html

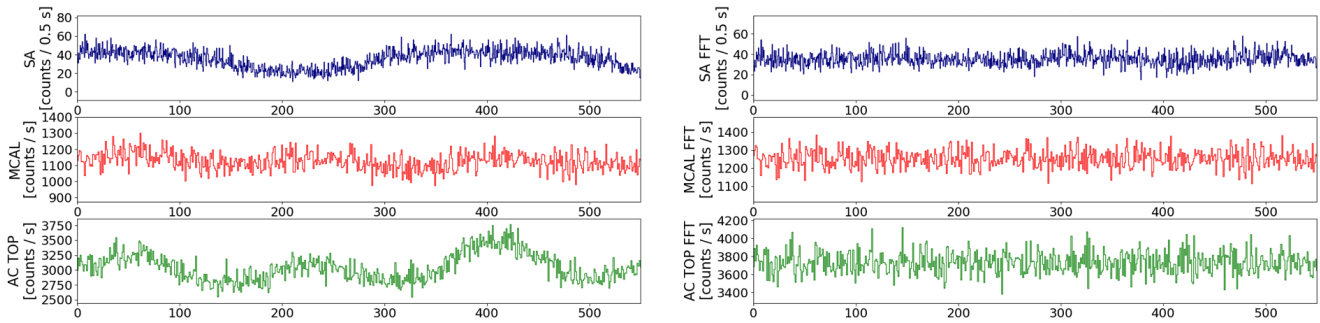

Figure 13: AGILE-RM light curves for the SuperAGILE, MCAL and AC Top detectors. The original data are shown in the left panel, while the right panel shows the light curves after trend removal.

5. AGILE web Control Room

We developed a Control Room that the AGILE Team can use to visualize the status of data acquisition from the satellite (e.g., the data flow) and a summary of scientific results generated by the AGILE RTA pipelines. This GUI is essential for real-time monitoring of the analysis results, especially during a follow-up of external science alerts.

The user can access the Control Room using a web browser and log in with the username and password provided only to the AGILE Team members. The connection address is constant, and the RTA administrators can route it to different servers in case of failures. The Control Room is based on a previous version of the web GUI developed by AGILE researchers and described in Zoli et al. (2019).

We implemented the GUI using a LAMP environment (Linux, Apache, MySQL, PHP) installed inside a Singularity container deployed at the INAF/OAS Bologna data center. We also deployed a backup system on a machine hosted in the ASI/SSDC data center (more details in Section 6). We implemented the GUI layout using the Bootstrap⁸ framework to enable responsive behavior compatible with smartphones and tablets. We used Javascript, HTML, PHP, and CSS as programming and markup languages.

The Control Room has a navigation menu with the following section and subsections:

- Home Page: a web page showing general information about the AGILE space mission, such as the data acquisition status, a preview of the results of the RTA pipelines, and the results related to the last science alert received;
- LVC Notices: this section opens a table of notices received by the GCN from the LVC collaboration;
- Last Notices: this section access a list of the last 15 notices received by the GCN from all facilities;
- Pipelines: this section opens a website dedicated to each of the AGILE RTA pipelines described in Section 2;

⁸<https://getbootstrap.com>

- Science Alerts: this section allows the user to choose one particular type of notice (e.g., FERMI/LAT) and open its list of notices;
- Monitoring: this section opens a selection box with several web pages to visualize details about the AGILE data flow or the monitoring of the software and hardware systems;
- AGILE Team: this section contains utility web pages such as the calendar of shifts and a web page to manually insert science alerts into the RTA system;
- Help: this section allows the user to open documents with the tutorial for the usage of the system.

The following sections describe the main Control Room web pages used by the AGILE Team during daily activities.

5.1. Homepage

The Control Room's home page contains tables, plots, and other information that the user can visualize to monitor the AGILE space mission. The first part of the home page shows a table of parameters to indicate the status of the LDA. This information displays the coverage time windows for each type of telemetry and the following expected contact coverage. When the system receives an external science alert, the Burst Advocate uses the Control Room to verify if the LDA covers the alert trigger time. If not, the automated results will be produced after the next contact. This table also indicates the name of the Burst Advocate in charge of the science alert monitoring for the current shift.

After this first section, the web page shows two plots related to the data acquisition flow. The first one shows the delay, expressed in hours, of three different data packets sent from the ASI/SSDC data center to the INAF/OAS Bologna data center. The delay usually depends on the schedule at the ground station for the data downlink, but when the delay increases over a given threshold, it causes issues in the data acquisition chain. The second plot shows the number of daily scheduled contacts between the satellite and the ground station, providing information on which contact has actually been acquired up to that moment.

The next section shows preliminary results from the AGILE/MCAL pipeline of the last five contacts (Figure

MCAL last 5 contacts

Contact Number	First Trigger (UTC)	Last Trigger (UTC)	N of triggers	GRBs	GRBlikes	STEs	TGFs	Actions
079446	2022-08-03 12:29:30	2022-08-03 14:11:18	68	0	1	0	0	Orbit Trend Triggers GRB GRBlIKE STE TGF
079445	2022-08-03 09:58:03	2022-08-03 12:29:30	81	0	0	0	0	Orbit Trend Triggers GRB GRBlIKE STE TGF
079444	2022-08-03 08:15:07	2022-08-03 09:58:03	112	0	4	0	1	Orbit Trend Triggers GRB GRBlIKE STE TGF
079443	2022-08-03 05:15:53	2022-08-03 08:13:32	51	0	0	0	0	Orbit Trend Triggers GRB GRBlIKE STE TGF
079441	2022-08-03 03:17:01	2022-08-03 05:12:27	79	0	0	0	0	Orbit Trend Triggers GRB GRBlIKE STE TGF

Figure 14: The figure shows a table of the AGILE/MCAL pipeline’s results on the last five contacts received. The green buttons open detail pages for each specific result.

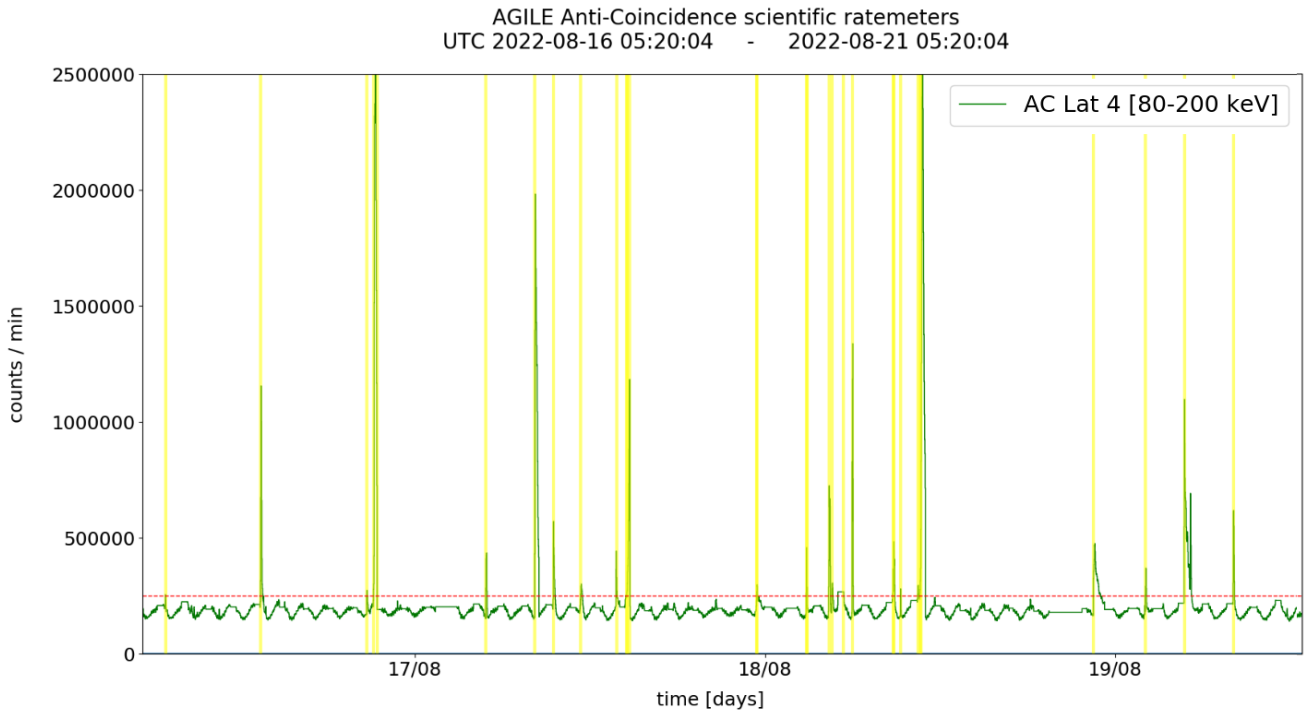

Figure 15: Light curve of the RM of the fourth ACS panel, pointed toward the Sun and therefore capable of detecting solar flares. An automated algorithm highlights with yellow bands the events with count rates exceeding a predefined threshold (red dashed line).

14). The GUI shows a table that summarizes any detected GRB and TGF. In addition, this table contains information about sub-threshold events (STE); short-duration signals in the AGILE-MCAL data with a statistical significance lower than the required threshold to classify them as GRBs. The presence of green buttons allows the AGILE Team to open detail pages related to that specific contact, containing further information about a variety of results, such as GRB or TGF.

The homepage presents a plot (Figure 15) showing the RM of the fourth ACS panel (used to detect solar flares) acquired in the last ten days. The candidate solar flares are highlighted with a yellow band.

The last section shows preliminary results of the RTA pipelines related to the last science alert, as received from the GCN. The user can open a related detailed page to visualize further information.

5.2. Last Notices

This web page presents a table with information on the last fifteen notices, as received by the GCN (Figure 16). The Burst Advocate can use this section to monitor the last transient events detected by other facilities, and to visualize the results of the AGILE RTA pipelines on their follow-up.

The table contains the following information on the received science alert:

Instrument Name	trigger time (UTC)	trigger time (TT)	notice time (UTC)	trigger id	seqnum	link
FERMI_GBM	2022-08-04T02:08:32.770	586663712.77	2022-08-04T02:09:12	681271717	1	Prompt Analysis Full Analysis Open Run Open Results
FERMI_GBM	2022-08-04T02:08:32.770	586663712.77	2022-08-04T02:09:02	681271717	0	Prompt Analysis Full Analysis Open Run Open Results

Figure 16: Table of the last 15 science alerts received by the GCN. The green buttons open additional web pages containing further details and plots for the visualization of the scientific results.

- Instrument Name: the name of the instrument that sent it (e.g., FERMI/GBM);
- Trigger time (UTC): the trigger time, in UTC format, of the transient event;
- Trigger time (TT): the trigger time of the transient event, in TT, relative to the AGILE mission elapsed time;
- Notice time (UTC): the time, in UTC format, of the moment in which the AGILE RTA pipeline received the alert. It can differ from the trigger time for several reasons (e.g., the processing time required to detect the transient event);
- Trigger ID: a unique ID that identifies the transient event. Different facilities can have different trigger ID formats;
- Sequence Number: a sequential number assigned by the Science Alert Receiver when it receives multiple alerts pertaining to the same trigger ID (e.g., updates on the same transient event);
- Links: a button linking to the Prompt Analysis web page, showing the results of the AGILE RTA pipeline (Section 3.1). A second button opens a web page containing scientific results from a larger time window of ± 1000 seconds (Section 3.2). Finally, two more buttons linking to the analyses' directories storing logs and result files;

5.3. AGILE Team and Help

These sections are used to describe the manual analysis procedure which the AGILE Team must follow to confirm a transient event detected with the AGILE RTA pipelines. In addition, the user can open a web page to manually insert a science alert. This feature is used when other automated systems fail. Finally, this section contains the templates that the AGILE Team can use to prepare circulars and notices.

6. AGILE RTA deployment and backup services

The AGILE RTA system is deployed on different physical servers using a Singularity container (Figure 17), allowing the reproducibility of the software system and the scientific results. In addition, through the container, we can deploy the system on physical servers with different configurations.

The RTA software runs on the AGILE Host 2 server hosted at the INAF/OAS Bologna data center, together with the container for the AGILE Control Room. This data center also hosts the AGILE Host 1 server, which contains a reduced version of the AGILE software, allowing researchers to execute manual scientific analyses.

We deployed a backup container for the RTA pipelines and the Control Room on the AGILE SSSC server, hosted at the ASI/SSDC Data Center. The backup system is essential to grant high availability in case of technical issues at the Bologna data center (e.g., a power outage).

The AGILE researchers and other AGILE software (e.g., the AGILEScience app for mobile devices) are routed to the operative container thanks to a switch in the connection link.

7. Deep Learning technologies for the detection of GRBs

We are investigating new analysis methods based on Deep Learning (DL, Lecun et al. (2015); Goodfellow et al. (2016)) technologies to improve the detection capabilities of GRBs of the AGILE RTA system. We have successfully developed two methods that use the Convolutional Neural Network (CNN) to analyze sky maps and time series generated from data acquired by the AGILE instruments.

The first method performs a classification of intensity maps (counts maps divided by exposure maps) of AGILE/GRID data to detect those containing GRBs. We tested this DL model using the GRBs presented in the catalogs (and updated online databases) of other γ -ray detectors:

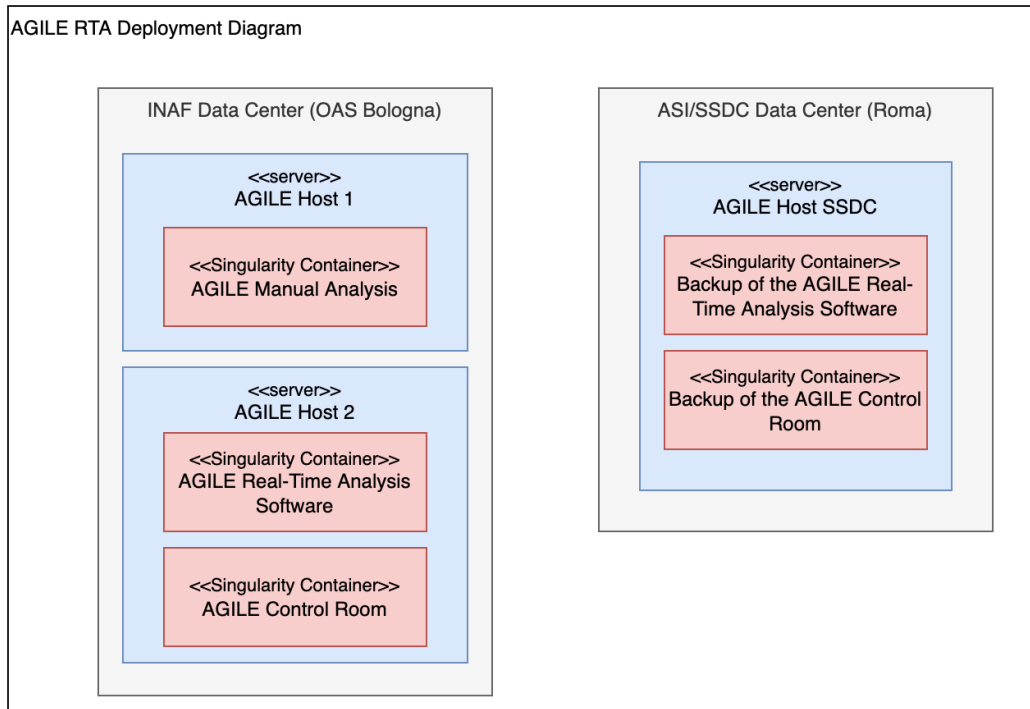

Figure 17: Deployment schema of the AGILE real-time analysis system. The system is deployed in two data centers geographically separated (one in Roma, the other in Bologna) to improve availability in case of failures.

Swift/BAT (Lien et al., 2016), Fermi/LAT (Ajello, 2019), and Fermi/GBM (von Kienlin et al., 2020). We generated the AGILE/GRID intensity maps from the archive data using the GRB times and sky coordinates listed in the catalogs. The GRBs contained in the catalogs are filtered to evaluate only intensity sky maps with a minimum exposure level. The DL model detects 21 GRBs with a $\sigma \geq 3$ out of the 193 GRBs filtered from the catalogs. It is worth noticing that not all GRBs detected by other space missions can be detected by AGILE/GRID, due to different energy ranges and instrument sensitivities. In addition, we compared the results of the DL model with those obtained with the standard analysis based on the Li&Ma method, and we found that, in this context, the DL model is able to detect more GRBs and with a better statistical significance. Further details about the implementation of the model and the results obtained are described in Parmiggiani et al. (2021). We are extending this model to introduce a new feature for the localization of the GRBs via an additional DL model which performs a regression on the coordinates of the source.

The second method implements an autoencoder with 1D convolution layers to analyze multivariate time series (MTS) acquired from the ACS RM. This method aims to detect GRBs performing an anomaly detection analysis. We tested the DL model using the GRBs appearing in the GRBWeb catalog⁹, which contains GRBs detected by different facilities (Coppin et al., 2020), and extracting the relative MTSs from the ACS archive. We filtered from the GRBWeb catalog 1586 GRBs, and from this list, the DL

⁹<https://heasarc.gsfc.nasa.gov/FTP/fermi/data/gbm/bursts/>

model detected 72 GRBs with a significance $\geq 3\sigma$. The model could not detect the remaining GRBs due to different energy ranges, sensitivity, and possible Earth occultations. This result demonstrates the capability of the DL model to detect GRBs. Out of the 72 detections, this model allowed us to detect for the first time 15 new GRBs in the AGILE data. A detailed description of the model and results can be found in Parmiggiani et al. (2023).

After the promising results obtained with the analysis of AGILE archive data using the two DL methods, we decided to perform further investigations on DL techniques to improve the AGILE RTA system. At the time of writing, we are also implementing and testing the two DL methods inside the AGILE RTA pipelines to collect results from the real-time scenario.

8. Conclusions

The manuscript describes the RTA pipelines developed for the AGILE space mission to detect transient sources in the multiwavelength and multimessenger astronomical landscape. The RTA pipelines enable serendipitous and follow-up detection of transients with a duration between less than two seconds (Short GRBs) and one hour (Solar Flares). We implemented these pipelines using the RTApipe framework, which provides all the features necessary to satisfy the software requirements. The main covered scenarios are: (i) analyzing data acquired by the detectors on board AGILE (GRID, MCAL) and relative RM, as soon as made available at the INAF/OAS Bologna data center; (ii) reacting to external science alerts by performing follow-up analyses

on transient events (e.g., GRBs, GWs, and neutrinos). The data analysis procedure is fully automated for both scenarios and does not require human intervention. In addition, the pipelines send email notifications to the AGILE Team when a transient source is detected and notices to the GCN network when a GRB is detected in the AGILE-MCAL data.

The analyses generate scientific results with low latency (from seconds to minutes) since the reception of the alert and the acquisition of data. The AGILE Team organizes personnel shifts in order to have at least one team member (Burst Advocate) available to monitor the scientific results. This task is performed continuously using the web GUI. Several papers, GCN circulars, GCN notices, and Astronomer's Telegrams have been published using the support of the RTA pipelines. A prompt follow-up of transient sources could not be possible without an automated analysis system.

The technologies and software architecture that we used to implement the AGILE RTA pipelines can be further used to develop other RTA software systems dedicated to other γ -ray space missions or ground-based observatories.

Acknowledgements

The AGILE Mission is funded by the Italian Space Agency (ASI) with scientific and programmatic participation by the Italian National Institute for Astrophysics (INAF) and the Italian National Institute for Nuclear Physics (INFN). The investigation is supported by the ASI grant I/028/12/6. We thank the ASI management for unfailing support during AGILE operations. We acknowledge the effort of ASI and industry personnel at the ASI ground station in Malindi (Kenya), at the Telespazio Mission Control Center at Fucino, and the data processing done at the ASI/SSDC in Rome: the success of AGILE scientific operations depends on the effectiveness of the data flow from Kenya to SSCDC and the data analysis and software management.

This accepted version of the manuscript is released under this license . The published version is available here <https://doi.org/10.1016/j.ascom.2023.100726>.

References

- Ajello, e.a., 2019. A Decade of Gamma-Ray Bursts Observed by Fermi-LAT: The Second GRB Catalog. *Astrophysical Journal* 878, 52. doi:10.3847/1538-4357/ab1d4e, arXiv:1906.11403.
- Bulgarelli, A., 2019. The AGILE Gamma-Ray observatory: software and pipelines. *Experimental Astronomy* 48, 199–231. doi:10.1007/s10686-019-09644-w.
- Bulgarelli, A., et al., 2014. The AGILE Alert System for Gamma-Ray Transients. *Astrophysical Journal* 781, 19. doi:10.1088/0004-637X/781/1/19, arXiv:1401.3573.
- Casentini, C., Verrecchia, F., Tavani, M., Ursi, A., Antonelli, L.A., Argan, A., Barbiellini, G., Bulgarelli, A., Caraveo, P., Cardillo, M., Cattaneo, P.W., Chen, A., Costa, E., Donnarumma, I., Feroci, M., Ferrari, A., Fuschino, F., Galli, M., Giuliani, A., Labanti, C., Lazzarotto, F., Lipari, P., Longo, F., Lucarelli, F., Marisaldi, M., Morselli, A., Paoletti, F., Parmiggiani, N., Pellizzoni, A., Piano, G., Pilia, M., Pittori, C., Vercellone, S., 2020. AGILE Observations of Two Repeating Fast Radio Bursts with Low Intrinsic Dispersion Measures. *Astrophysical Journal, Letters* 890, L32. doi:10.3847/2041-8213/ab720a, arXiv:1911.10189.
- Coppin, P., de Vries, K.D., van Eijndhoven, N., 2020. Identification of gamma-ray burst precursors in fermi-gbm bursts. *Phys. Rev. D* 102, 103014. URL: <https://link.aps.org/doi/10.1103/PhysRevD.102.103014>, doi:10.1103/PhysRevD.102.103014.
- Goodfellow, I., Bengio, Y., Courville, A., 2016. *Deep Learning*. MIT Press. <http://www.deeplearningbook.org>.
- von Kienlin, A., et al., 2020. The fourth fermi-gbm gamma-ray burst catalog: A decade of data. *The Astrophysical Journal* 893, 46. URL: <https://dx.doi.org/10.3847/1538-4357/ab7a18>, doi:10.3847/1538-4357/ab7a18.
- Lecun, Y., Bengio, Y., Hinton, G., 2015. Deep learning. *Nature* 521, 436–444. doi:10.1038/nature14539.
- Li, T.P., Ma, Y.Q., 1983. Analysis methods for results in gamma-ray astronomy. *Astrophysical Journal* 272, 317–324. doi:10.1086/161295.
- Lien, A., et al., 2016. The Third Swift Burst Alert Telescope Gamma-Ray Burst Catalog. *Astrophysical Journal* 829, 7. doi:10.3847/0004-637X/829/1/7, arXiv:1606.01956.
- Lucarelli, F., Tavani, M., Piano, G., Bulgarelli, A., Donnarumma, I., Verrecchia, F., Pittori, C., Antonelli, L.A., Argan, A., Barbiellini, G., Caraveo, P., Cardillo, M., Cattaneo, P.W., Chen, A., Colafrancesco, S., Costa, E., Del Monte, E., Di Cocco, G., Ferrari, A., Fioretti, V., Galli, M., Giommi, P., Giuliani, A., Lipari, P., Longo, F., Mereghetti, S., Morselli, A., Paoletti, F., Parmiggiani, N., Pellizzoni, A., Picozza, P., Pilia, M., Rappoldi, A., Trois, A., Ursi, A., Vercellone, S., Vittorini, V., AGILE Team, 2019. AGILE Detection of Gamma-Ray Sources Coincident with Cosmic Neutrino Events. *Astrophysical Journal* 870, 136. doi:10.3847/1538-4357/aaf1c0, arXiv:1811.07689.
- Marisaldi, M., Fuschino, F., Labanti, C., Galli, M., Longo, F., Del Monte, E., Barbiellini, G., Tavani, M., Giuliani, A., Moretti, E., Vercellone, S., Costa, E., Cutini, S., Donnarumma, I., Evangelista, Y., Feroci, M., Lapshov, I., Lazzarotto, F., Lipari, P., Mereghetti, S., Pacciani, L., Rapisarda, M., Soffitta, P., Trifoglio, M., Argan, A., Boffelli, F., Bulgarelli, A., Caraveo, P., Cattaneo, P.W., Chen, A., Cocco, V., D'Ammando, F., De Paris, G., Di Cocco, G., Di Persio, G., Ferrari, A., Fiorini, M., Froyland, T., Gianotti, F., Morselli, A., Pellizzoni, A., Perotti, F., Picozza, P., Piano, G., Pilia, M., Prest, M., Pucella, G., Rappoldi, A., Rubini, A., Sabatini, S., Striani, E., Trois, A., Vallazza, E., Vittorini, V., Zambra, A., Zanello, D., Antonelli, L.A., Colafrancesco, S., Gasparini, D., Giommi, P., Pittori, C., Preger, B., Santolamazza, P., Verrecchia, F., Salotti, L., 2010. Detection of terrestrial gamma ray flashes up to 40 MeV by the AGILE satellite. *Journal of Geophysical Research (Space Physics)* 115, A00E13. doi:10.1029/2009JA014502.
- Meszaros, P., Fox, D.B., Hanna, C., Murase, K., 2019. Multi-messenger astrophysics. *Nature Reviews Physics* 1, 585–599. doi:10.1038/s42254-019-0101-z, arXiv:1906.10212.
- Parmiggiani, N., Bulgarelli, A., Beneventano, D., Fioretti, V., Di Piano, A., Baroncelli, L., Addis, A., Tavani, M., Pittori, C., Oya, I., 2022. The rtape framework for the gamma-ray real-time analysis software development. *Astronomy and Computing* 39, 100570. URL: <https://www.sciencedirect.com/science/article/pii/S2213133722000178>, doi:https://doi.org/10.1016/j.ascom.2022.100570.
- Parmiggiani, N., Bulgarelli, A., Fioretti, V., Di Piano, A., Giuliani, A., Longo, F., Verrecchia, F., Tavani, M., Beneventano, D., Macaluso, A., 2021. A Deep Learning Method for AGILE-GRID Gamma-Ray Burst Detection. *Astrophysical Journal* 914, 67. doi:10.3847/1538-4357/abfa15, arXiv:2105.08841.
- Parmiggiani, N., Bulgarelli, A., Ursi, A., Macaluso, A., Di Piano, A., Fioretti, V., Aboudan, A., Baroncelli, L., Addis, A., Tavani, M., Pittori, C., 2023. A Deep-learning Anomaly-detection Method to Identify Gamma-Ray Bursts in the Ratemeters of the AGILE Anticoincidence System. *Astrophysical Journal* 945, 106. doi:10.3847/1538-4357/acba0a.
- Pittori, C., The AGILE-SSDC Team, 2019. The AGILE data center and its legacy. *Rendiconti Lincei. Scienze Fisiche e Naturali* 30, 217–223. doi:10.1007/s12210-019-00857-x, arXiv:1911.12314.
- Tavani, M., et al., 2009. The AGILE Mission. *Astronomy and Astrophysics* 502, 995–1013. doi:10.1051/0004-6361/200810527, arXiv:0807.4254.
- Tavani, M., Casentini, C., Ursi, A., Verrecchia, F., Addis, A., Antonelli, L.A., Argan, A., Barbiellini, G., Baroncelli, L., Bernardi, G., Bianchi, G., Bulgarelli, A., Caraveo, P., Cardillo, M., Cattaneo, P.W., Chen, A.W.,

- Costa, E., Del Monte, E., Di Cocco, G., Di Persio, G., Donnarumma, I., Evangelista, Y., Feroci, M., Ferrari, A., Fioretti, V., Fuschino, F., Galli, M., Gianotti, F., Giuliani, A., Labanti, C., Lazzarotto, F., Lipari, P., Longo, F., Lucarelli, F., Magro, A., Marisaldi, M., Mereghetti, S., Morelli, E., Morselli, A., Naldi, G., Pacciani, L., Parmiggiani, N., Paoletti, F., Pellizzoni, A., Perri, M., Perotti, F., Piano, G., Picozza, P., Pilia, M., Pittori, C., Puccetti, S., Pupillo, G., Rapisarda, M., Rappoldi, A., Rubini, A., Setti, G., Soffitta, P., Trifoglio, M., Trois, A., Vercellone, S., Vittorini, V., Giommi, P., D'Amico, F., 2021. An X-ray burst from a magnetar enlightening the mechanism of fast radio bursts. *Nature Astronomy* 5, 401–407. doi:10.1038/s41550-020-01276-x, arXiv:2005.12164.
- Ursi, A., Romani, M., Piano, G., Verrecchia, F., Longo, F., Pittori, C., Tavani, M., Bulgarelli, A., Cardillo, M., Casentini, C., Cattaneo, P.W., Costa, E., Feroci, M., Fioretti, V., Foffano, L., Lucarelli, F., Marisaldi, M., Morselli, A., Pacciani, L., Parmiggiani, N., Tempesta, P., Trois, A., Vercellone, S., 2022. AGILE Observations of GRB 220101A: A “New Year’s Burst” with an Exceptionally Huge Energy Release. *Astrophysical Journal* 933, 214. doi:10.3847/1538-4357/ac746c, arXiv:2205.14199.
- Ursi, A., Tavani, M., Frederiks, D.D., Romani, M., Verrecchia, F., Marisaldi, M., Aptekar, R.L., Antonelli, L.A., Argan, A., Bulgarelli, A., Barbiellini, G., Caraveo, P., Cardillo, M., Casentini, C., Cattaneo, P.W., Chen, A., Costa, E., Donnarumma, I., Evangelista, Y., Feroci, M., Ferrari, A., Fuschino, F., Galli, M., Giuliani, A., Labanti, C., Lazzarotto, F., Longo, F., Lucarelli, F., Morselli, A., Paoletti, F., Parmiggiani, N., Piano, G., Pilia, M., Pittori, C., Svinkin, D.S., Trois, A., Tsvetkova, A.E., Vercellone, S., Vittorini, V., 2020. AGILE and Konus-Wind Observations of GRB 190114C: The Remarkable Prompt and Early Afterglow Phases. *Astrophysical Journal* 904, 133. doi:10.3847/1538-4357/abc2d4.
- Verrecchia, F., Tavani, M., Bulgarelli, A., Cardillo, M., Casentini, C., Donnarumma, I., Longo, F., Lucarelli, F., Parmiggiani, N., Piano, G., Pilia, M., Pittori, C., Ursi, A., Agile Team, 2019. AGILE search for gamma-ray counterparts of gravitational wave events. *Rendiconti Lincei. Scienze Fisiche e Naturali* doi:10.1007/s12210-019-00854-0.
- Zoli, A., Bulgarelli, A., Tavani, M., Fioretti, V., Marisaldi, M., Parmiggiani, N., Fuschino, F., Gianotti, F., Trifoglio, M., 2019. The AGILE Pipeline for Gravitational Waves Events Follow-up, in: Molinaro, M., Shortridge, K., Pasion, F. (Eds.), *Astronomical Data Analysis Software and Systems XXVI*, p. 139.