



Publication Year	2022
Acceptance in OA	2025-03-07T13:39:03Z
Title	Toward ARIEL's primary mirror
Authors	TOZZI, Andrea, BRUCALASSI, Anna, CANESTRARI, Rodolfo, CHIOETTO, PAOLO, Del Vecchio, Ciro, CARBONARO, Luca, CORTECCHIA, Fausto, DIOLAITI, Emiliano, Eccleston, Paul, FALCINI, Gilberto, FERRUZZI, Debora, GOTTINI, Daniele, GUERRIERO, Elisa, IUZZOLINO, Marcella, LILLI, Riccardo, LOMBINI, Matteo, MALAGUTI, Giuseppe, MICELA, Giuseppina, Miceli, Federico, MORGANTE, GIANLUCA, Pace, Emanuele, Pascale, Enzo, PIAZZOLLA, RAFFAELE, Preti, Giampaolo, Salatti, Mario, Scippa, Antonio, Tinetti, Giovanna, Tommasi, Elisabetta, Vernani, Dervis, ZUPPELLA, PAOLA
Publisher's version (DOI)	10.1117/12.2628906
Handle	http://hdl.handle.net/20.500.12386/36510
Serie	PROCEEDINGS OF SPIE
Volume	12180

Toward ARIEL's primary mirror

Andrea Tozzi^{*a}, Anna Brucalassi^a, Rodolfo Canestrari^g, Paolo Chioetto^{b,c,d}, Ciro Del Vecchio^a, Luca Carbonaro^a, Fausto Cortecchia^e, Emiliano Diolaiti^e, Paul Eccleston^f, Gilberto Falcini^a, Debora Ferruzzi^a, Daniele Gottini^a, Elisa Guerriero^g, Marcella Iuzzolino^a, Riccardo Lilli^m, Matteo Lombini^e, Giuseppe Malaguti^e, Giuseppina Micela^g, Federico Miceli^a, Gianluca Morgante^o, Emanuele Pace^h, Enzo Pascaleⁱ, Raffaele Piazzolla^k, Giampaolo Pretiⁱ, Mario Salatti^k, Antonio Scippa^m, Giovanna Tinetti^l, Elisabetta Tommasi^k, Dervis Vernaniⁿ, Paola Zuppella^{a,c}

^aINAF-Osservatorio Astrofisico di Arcetri, Largo E. Fermi 5, 50125 Firenze, Italy

^bCentro di Ateneo di Studi e Attività Spaziali "Giuseppe Colombo" - CISAS, Via Venezia 15, 35131 Padova, Italy

^cINAF-Osservatorio Astronomico di Padova, Vicolo dell'Osservatorio 5, 35122 Padova, Italy

^dCNR-Istituto di Fotonica e Nanotecnologie di Padova, Via Trasea 7, 35131 Padova, Italy

^eINAF-Osservatorio di Astrofisica e Scienza dello spazio di Bologna, Via Piero Gobetti 93/3, 40129 Bologna, Italy

^fRAL Space, STFC Rutherford Appleton Laboratory, Didcot, Oxon, OX11 0QX, UK

^gINAF-Osservatorio Astronomico di Palermo, Piazza del Parlamento 1, 90134 Palermo, Italy

^hDipartimento di Fisica ed Astronomia-Università degli Studi di Firenze, Largo E. Fermi 2, 50125 Firenze, Italy

ⁱDipartimento di Fisica, La Sapienza Università di Roma, Piazzale Aldo Moro 2, 00185 Roma, Italy

^jINAF-IAPS, Via del Fosso del Cavaliere 100, I-00133 Rome, Italy

^kASI, Agenzia Spaziale Italiana, Via del Politecnico snc, Roma, Italy

^lDepartment of Physics and Astronomy, University College London, Gower Street, London WC1E 6BT, UK

^mUniversità Degli Studi di Firenze, P.zza San Marco 4, 50121, Firenze, Italy

ⁿMedia Lario S.r.l., Via al Pascolo 10, 23842, Bosisio Parini (LC), Italy.

^oINAF-Osservatorio Astronomico di Bologna, Via Gobetti 93/3, 40129 Bologna, Italy

ABSTRACT

Ariel (Atmospheric Remote-Sensing Infrared Exoplanet Large Survey) is the adopted M4 mission of ESA "Cosmic Vision" program. Its purpose is to conduct a survey of the atmospheres of known exoplanets through transit spectroscopy. Launch is scheduled for 2029.

Ariel scientific payload consists of an off-axis, unobscured Cassegrain telescope feeding a set of photometers and spectrometers in the waveband between 0.5 and 7.8 μm , and operating at cryogenic temperatures.

The Ariel Telescope consists of a primary parabolic mirror (M1) with an elliptical aperture of 1.1 m of major axis and 0.7 m of minor axis, followed by a hyperbolic secondary (M2), a parabolic recollimating tertiary (M3) and a flat folding mirror (M4).

The Primary mirror is a very innovative device made of lightened aluminum. Aluminum mirrors for cryogenic instruments and for space application are already in use, but never before now it has been attempted the creation of such a large mirror made entirely of aluminum: this means that the production process must be completely revised and fine-tuned, finding new solutions, studying the thermal processes and paying a great care to the quality check.

By the way, the advantages are many: thermal stabilization is simpler than with mirrors made of other materials based on glass or composite materials, the cost of the material is negligible, the shape may be free and the possibility of making all parts of the telescope, from optical surfaces to the structural parts, of the same material guarantees a perfect alignment at whichever temperature.

This paper describes the methodology and preliminary results of this manufacturing process and discusses future steps

Keywords: space telescope, Ariel mission, aluminium mirror

1. INTRODUCTION

The methodology of building large aluminum mirrors for space missions is not yet defined and one of the main items of the entire process is the validation methodology of the single steps. Moreover, the scientific requirements of the mission are such that the error budget leaves very little room for errors related to the processing of optical surfaces, as visible in the preliminary Error Budget table [9, 10] showed just below:

Table 1 Error Budget for the telescope assembly.

WFE Budget: Common items v1 - 20220125		wavelength [nm]: 3000		WFE		Surface Error (SFE)		SFE M1- M4	
Manufacturing errors			Z4-Z36 rms	HF rms	SFE rms				
M1	(OAP)	160.0	79.4	10	80.0				calculated after EE optimization
M2	(HYP)	84.0	42.0	2	42.0				technical note ARIEL-INAF-PL-TN-015 and requirements ARIEL-SAP-INST-TN-001 (waveband analysis: 550 nm- 7800 nm)
M3	(OAP)	24.0	11.8	2	12.0				
M4	(PLN)	24.0	11.8	2	12.0			91.9	
microroughness & throughput		0.0		10.6					
Assembly and alignment errors									calculated after EE optimization
Misalignment @ ground		23.0							Technical note ARIEL-CNR-PL-TN-004
assembly deformations		23.0							TBC ver 6.0 Zemax design
measurement error		20.0							TBC ver 6.0 Zemax design
Environmental flight errors									
Thermal deformation		20.8							STOP analysis ARIEL-CSL-PL-TN-007 (case 6)
Jitter		4.0							@ 10° of depointing, ARIEL-RAL-PL-DD-001
Gravity release		15.0							STOP analysis ARIEL-CSL-PL-TN-007
Optical design error									
		4.1							@ version 6.0 (50K or 293K) ARIEL-RAL-PL-TN-001
Total error budget for Telescope		189.6							< 200 nm as ARIEL-RAL-PL-DD-001 and Marechal's principle
Strehl Ratio @ 3 um		85.4%							> 83.8% as ARIEL-SAP-PL-TN-005 rev 3 and Ruze formula

We can divide the process of manufacturing, assembly and test of the Primary Mirror (M1) of ARIEL in the following points:

- 1) selection and procurement of the aluminum
- 2) thermal treatments to be applied to the aluminum
- 3) diamond turning machining of the optical surface

- 4) polishing process of the reflecting surface
- 5) definition of the shape of the lightening and support structure

In the following, a description of the single steps is reported for the BreadBoards prototype mirrors of M1 and for M1.

1.1 Selection and procurement of the aluminum

During Phase A of the Ariel mission development, a trade-off study was conducted to determine the best aluminium alloy and forge to be used for the telescope mirrors substrates and supporting structures. The outcome was that Al6061-T651 presented the best characteristics in terms of cost, availability and performance.

Based on the discussions and analyses, a set of initial requirements was compiled (Table 2) and presented to providers for availability, feasibility and feedback. Apparently, the only available forge for our intended purposes was rolled plate, because of the size required. There was also no option on the cutting direction with respect to the lamination direction. Given the size of the order, we also determined that a custom order to the provider to select the material in terms of specific characteristics appears impossible.

In parallel, a set of samples from the same aluminium batch used for the PTM TDA program had been delivered to ESA to perform metallographic tests and measurements. From the results, it seems to be possible to revise and possibly relax the mirror requirements.

Table 2 Requirements for the aluminum 6061-T651 procurement.

<i>item #</i>	<i>name</i>	<i>description</i>	<i>nominal dimension</i>	<i>requested dimension</i>
1	TEST MIRROR (BB700)	shape is circle	700 mm diameter	710mm diameter, 152 mm thickness (TBC)
2	FINAL MIRRORS (FM)	shape is elliptical	1120 x 760 mm	1120x760 mm, 190 mm thickness (TBC)
<i>specification #</i>	<i>name</i>	<i>argument</i>		<i>requested value</i>
1	R-TEL-M1-0210	M1 material		The M1 shall be made of Al6061-T651
2	R-TEL-M1-0212	Aluminium grain size		The aluminium grain size shall be in the range 40-10 μ m.
3	R-TEL-M1-0214	Precipitates size		The size of Mg2Si precipitates shall be equal or smaller than 1 μ m.
4	R-TEL-M1-0216	Content of precipitates		The content of Mg2Si precipitates shall be equal or smaller than 1.5%.
5	R-TEL-M1-0218	Pores presence		There shall be no evidence of pores under dye penetrant test.
6	R-TEL-M1-0219	Cutting orientation		If the mirror blank shall be cutted from an extruded bar, cutting orienta shall be TBD degrees. As alternative it will taken into account the possibil to use rolled plate aluminum

The specifications related to the requirements R-TEL-M1-0212 and R-TEL-M1-0214, in terms of grain size and Mg2Si inclusion dimension, are not given by any provider but seems to be the most critical ones: to mitigate this problem, we are planning to adopt all the steps of a thermal process described in [3], applied to the mirror after the rough machine. Other fundamental papers related to aluminum mirrors are [1, 2] describing the use and the characteristic of instruments that make use of aluminum mirrors.

Table 3 below shows the list of providers that have been surveyed. Only Constellium company is a forger, the others are resellers: the customer application Engineer from Constellium confirmed us that the merger, forging and rolling processes take place in their factories in France, near Grenoble or Issoire. Constellium was also the only provider that could provide a measurement of the material porosity. No provider can certify the size of grains and precipitates, nor provide measurements before purchasing the bulk material. By the way Constellium seems to be the most reliable.

The specifications related to the requirements R-TEL-M1-0212 and R-TEL-M1-0214, in terms of grain size and Mg₂Si inclusion dimension, are not given by any provider but seems to be the most critical ones: to mitigate this problem, we are planning to adopt all the steps of a thermal process described in [3], applied to the mirror after the rough machine. Other fundamental papers related to aluminum mirrors are [1, 2] describing the use and the characteristic of instruments that make use of aluminum mirrors.

Table 3. Survey of aluminum providers.

Company	notes	producer	contact	contact
Airoldi Metalli	AMS-STD-2154 (class A)	NO (RUSAL ?)	Tel.: +39 031 3574.111 Fax: +39 031 3572.077	E-mail: info@airoldimetalli.it
Metalweb	UK Metal distributor with the ability to deal with special requests	NO (RUSAL ?)	http://www.metalweb.co.uk/product/aluminium/aluminium-rolled-plate-sheet/	info@metalweb.co.uk
Constellium	European Aluminium producer ASTM B594 Class A	YES: Grenoble, Issoire	https://www.constellium.com/markets-applications/aerospace	sales.extrusion@constellium.com bernard.demenstral@constellium.com
Kaiser Aluminium	US Aluminium Producer (see TW metals)	--	https://www.kaiseraluminum.com/products/	Patrice.Boilletot@KaiserAluminum.com
Novelis	US Aluminium Producer	--	https://novelis.com/aerospace/	TBD
RUSAL	Moscow Alu. Prod.	YES	https://rusal.ru	documents@rusal.com
TW Metals	ASTM B594 Class A	NO (KAISER USA)	TW Metals Italy S.r.l.Zona ASI - Vega 2, 81030 Teverola (CE) Teverola, Caserta 80011 Tel. 39 0823 1560040	cesare.travino@twmetals.it

1.2 Thermal treatments.

The thermal process is extremely challenging and it is not achievable by a single company: in Table 3 a list of the steps as described in [3] is reported with a description. For each step a reliable company that can provide the treatment has been found after a market survey. A possible variation to the original recipes [3] can be applied: the Hot Isostatic Pressing (HIP). It is a method to reduce porosity, to improve the mechanical properties, especially the fatigue strength, and to reduce the Mg₂Si inclusions. This is achieved by heating the castings to temperatures below the solidus temperature (500-520°C) and simultaneously applying a high isostatic inert gas pressure (170-180 MPa). Unfortunately, because of limitation to the budget and the very long process for the qualification of this new treatment, it has been decided not to include this process into our de-risking activity: so doing the original recipes of [3] has been implemented.

Table 3. Thermal Treatment and possible solution & location.

MDL step	Goddard step	SRS Goddard-NASA cycle	Deliverables, metrology and comments	Company	Location
1	1	Rough machine	- photographic evidence of setup and samples/Visual Inspection	INAF	
2	3	Solution treatment at 530 C	- temperature curves - temp. sensors positions - photographic evidence of setup and map/photo of samples location within the setup	TAG	Lecco (IT)
3	4	Quench within 15 sec in 28% UCON Quenchant A at 29-35 C	- samples photos/Visual Inspection		
4	new_4bis	Age at 175 C, 8 hrs (necessary after step 4)	- temperature curves - temp. sensors positions - photographic evidence of setup and map/photo of samples location within the setup - samples photos/Visual Inspection	TAG	Lecco (IT)
5	5	Uphill quench: Allow to reach 23 C, slowly place in LN ₂ , dunk in boiling H ₂ O	- temperature curves - temp. sensors positions - photographic evidence of setup and map/photo of samples location within the setup - samples photos/Visual Inspection	ILK Dresden	Dresden (GE)
6	7	Finish machine	- photographic evidence of setup and map/photo of samples location within the setup - samples photos/Visual Inspection	INAF	
7	9	TC 3 times at rates not exceeding 1.7 C/min, cool to 83 K, hold for 30 min, heat to 23 C, hold for 15 min, heat to 150 C, hold 30 min, cool to 23 C	- temperature curves - temp. sensors positions - photographic evidence of setup and map/photo of samples location within the setup - samples photos/Visual Inspection	Frigerio Stefano	Lecco (IT)
8	10a	SPDT	- photographic evidence of setup and map/photo of samples location within the setup - samples photos/Visual Inspection - roughness measurements - surface error measurement (interferometric)	LT Ultra	Herdwangen-Schönach (GE)
9	10b	Polishing	- photographic evidence of setup and map/photo of samples location within the setup - samples photos/Visual Inspection - roughness measurements - surface error measurement (interferometric)	Media Lario	Lecco (IT)
10	11	TC 3 times at rates not exceeding 1.7 C/min; cool to 83 K, hold for 30 min, heat to 23 C, hold for 15 min, heat to 150 C, hold 30 min, cool to 23 C (cleanroom not needed)	- temperature curves - temp. sensors positions - photographic evidence of setup and samples/Visual Inspection - interferometric measurements before and after the cycles	ILK Dresden	Dresden (GE)
11	12	293 K and 50 K, 3 TCs	- temperature curves - temp. sensors positions - photographic evidence of setup and map/photo of samples location within the setup - samples photos/Visual Inspection - interferometric measurements before and after the cycles (by INAF)	INAF-BO	Bologna (IT)

The step number 3 seems to be the critical one: for reducing straightening activity a quenching in water-polymer solutions seem to be mandatory. Quenching of formed sheet-metal parts in aqueous solutions of polyalkylene glycol or in similar inversely soluble media has significantly reduced the cost of straightening these parts after quenching. The SAE heat-treatment specification AMS-2770 recommends, for several alloys, maximum thicknesses that can be quenched in solutions of specific concentrations while maintaining acceptable property levels [4] as visible in Figure 1.

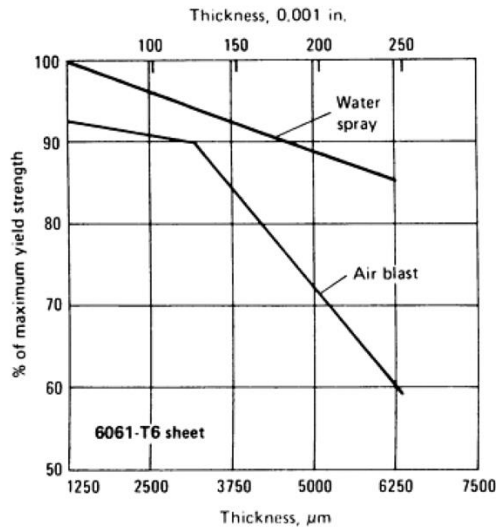

Figure 1 Effect of quenching medium on strength of 6061-T6. Water-immersion quench equals 100%.

Control of coolant flow will minimize decrease in mechanical properties [4].

The de-risking activity related to the use of the aluminum foreseen different type of tests for the different step of the thermal process: samples of 50 mm and 150 mm diameter for the polishing, small samples for the measure of the CTE and crystallographic measures, samples for the elastic module, breaking load, yield strength and finally, last but most important step, the use of two test mirrors, called BreadBoards (BB700) on which we have tested the processes and ideas that came to our mind in order to be able to carry out the creation of a mirror with such stringent manufacturing parameters, operating in a complex environment such as that of a space mission.

1.3 Diamond turning machining of the optical surface

After the machining of the mirrors the diamond turning process is performed by LT-Ultra (Germany). As preliminary activity a couple of Breadboards have been polished: they are 700 mm diameter spherical mirrors, having the same light weighting shape of M1 and the same mechanical interfaces. Outer diameter 700.00 mm, thickness at outer edge 85.65 mm and thickness at center 60.00 mm. One of them, called BB700#2 is without thermal treatments, and the second one, called BB700#1, has done all the thermal treatments as described in 1.2.

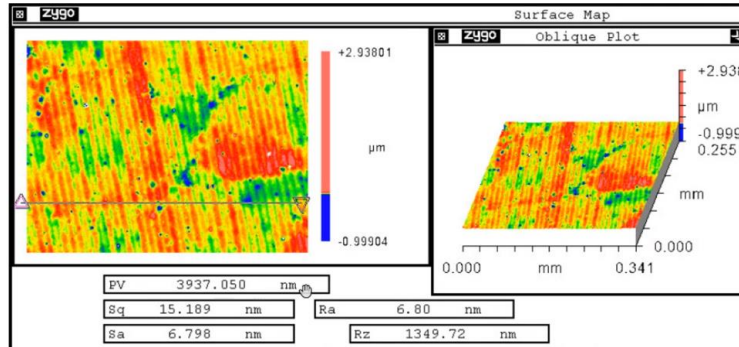

Figure 2 Measurement of the roughness of BB700#2. The residual effects of the Diamond Turning process are visible.

After the diamond turning the surface error of the breadboard mirror is measured (348 nm RMS) and the surface roughness (7 nm RMS), well below the requirements that were 1 μm and 10 nm respectively. Same interferometric measurements have been repeated by Media Lario S.r.l. (MDL) with same results.

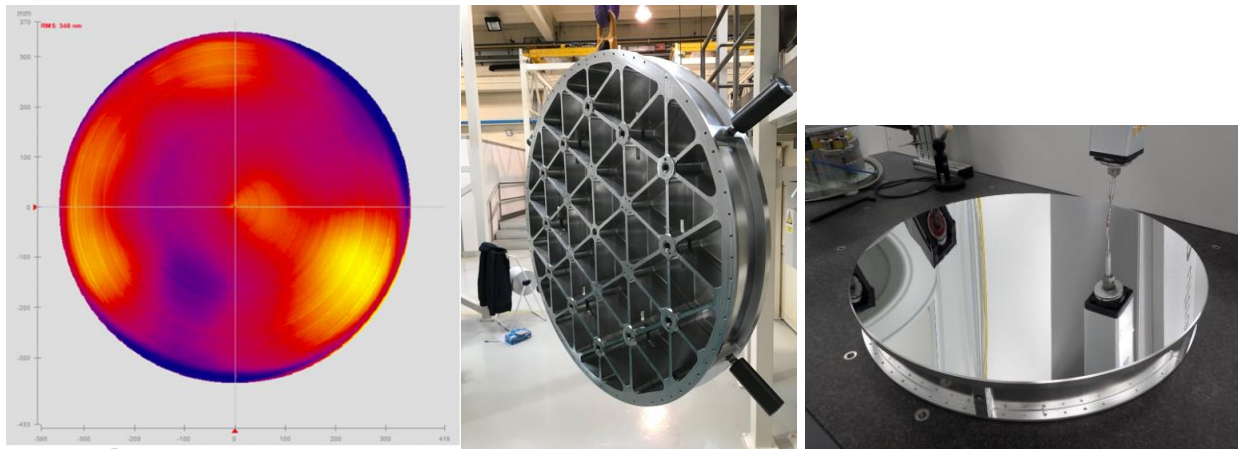

Figure 3 Prototype mirror BB700#2 (700 mm diameter) after the diamond turning (348 nm RMS): on the left the interferogram of the diamond turned surface. Processing residues are visible as concentric circles.

For the qualification of the diamond turning machine the same experimental setup of the polishing process is used (Figure 4): the bread board is kept in vertical position using a couple of cylinders, placed under the mirror itself and located in a position to minimize gravity-related stresses on the optical surface. Being a spherical mirror and not a parabolic mirror as M1 flight model, it is simply optical coupled to the interferometer in a confocal configuration.

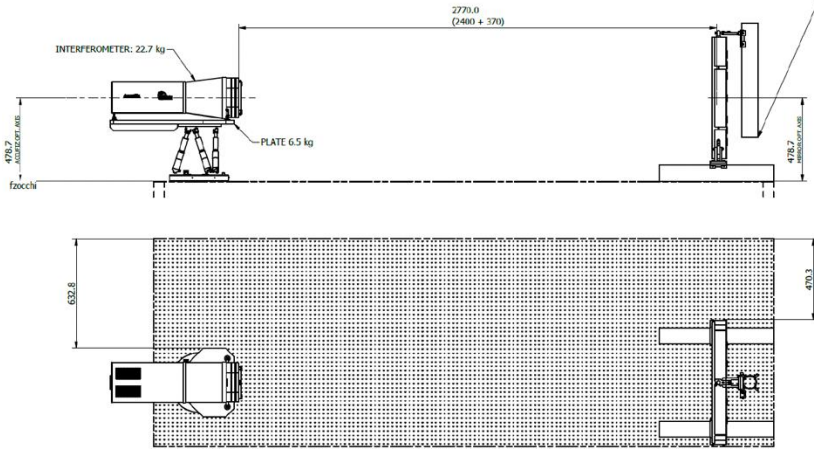

Figure 4 Prototype mirror BB700#2 under interferometric measurement in Media Lario S.r.l.

1.4 Polishing process

The flight model aluminium mirrors are planned to be diamond turned and polished to reduce surface roughness, lowering scattering at the waveband of interest and improving reflectivity. Polishing shall as well allow to deterministically correct the surface shape and mitigate residual surface errors left from the previous machining steps. Aluminum alloys are notoriously difficult to polish down to less than a few nanometers RMS of surface roughness, and for this reason they are used mostly for IR instruments that have less stringent requirements on surface finish. Results of directly polishing aluminum alloys are heavily influenced by grain structure and orientation. Polishing of Al6061-T651 in rolled plate form is particularly difficult because of easy detachment of aggregates of heavy components (such as iron and magnesium) that produce micro-holes and scratches on the surface.

The figuring and polishing process of the primary mirror (M1) is baselined on the Bonnet Polishing technique that Media Lario has implemented on the ZEEKO IRP machines, with namely the 1200X accommodating substrates up to 1.2 m. The Bonnet Polishing technique consists of a rotating platform on which the mirror is mechanically mounted, and a spindle mounted on a robotic arm. The polishing tool (also called bonnet) is mounted on the head of a multi-axis CNC machine. Polishing is achieved by chemical and mechanical interaction between the spinning bonnet, the mirror surface and the abrasive slurry.

There are several process parameters that involve the spinning speed of the bonnet, its contact pressure and area on the mirror and the slurry (e.g. abrasive type, grain size, density, viscosity). The correction process is based on a dwell map calculated from the convolution of the bonnet transfer function with the mirror surface error measured by the interferometer, so that the resulting process corrects the shape error of the mirror by selective removal of material on the mirror surface. The full correction routine requires several iterative runs, each correcting up to 80% of the input error. The initial runs eliminate diamond machining marks and address low spatial frequency errors. The following runs correct the mid spatial frequency errors, often using smaller bonnets. Final polishing follows with the last few runs to achieve the final high spatial frequency roughness specifications. The total process time depends on the size of the mirrors and on the residual surface error of the incoming diamond machined substrate, which is in the range of 250 nm and 1000 nm RMS for the small and large mirrors.

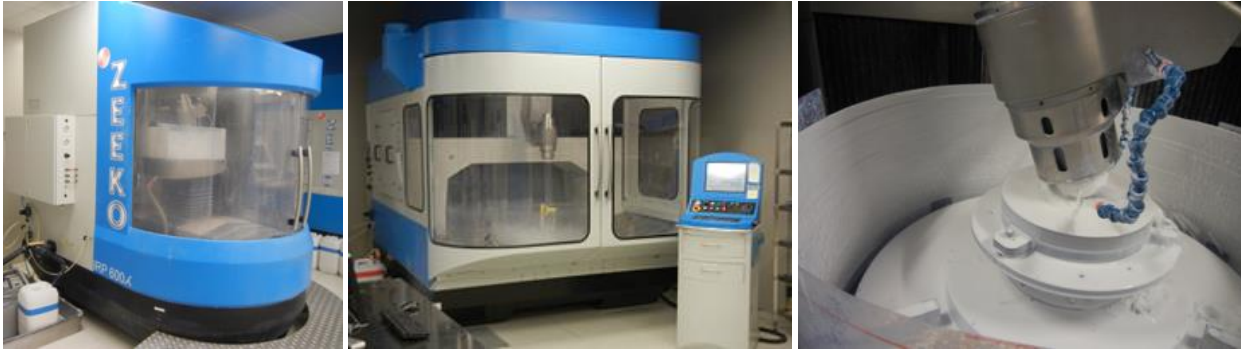

Figure 5 Zeeko IRP 600X and 1200X (left, centre), and bonnet polishing process on Al/NiP substrate (right).

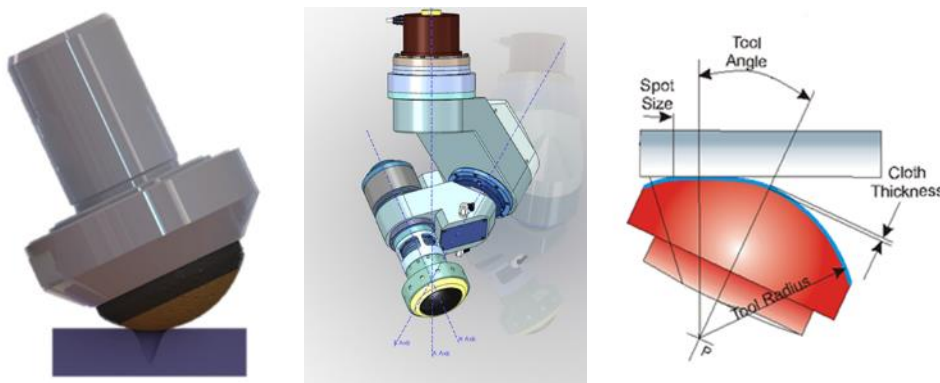

Figure 6 Bonnet in working position (left), mounted on the CNC machine (centre) and illustration of its geometrical parameters (right)

The Bonnet Polishing technique has been extensively applied in Media Lario for the manufacturing of aspheric light-weighted mirrors on glass and metal substrates.

For these reasons, the de-risking activity based on the BB700 models and the use of large samples of 6061T651 aluminum coming from the same blocks of the two BB700s has been foreseen.

Several 150 mm diameter flat samples were prepared from the same Al6061-T651 plate procured by INAF for the manufacturing of the primary mirror (M1) breadboards. To allow an early development of the polishing process, some samples were fast-tracked and machined without applying all the thermal treatments. On top of that, additional samples were as well prepared following the complete manufacturing flow, including all the thermal treatments. At the time of writing this paper, the intended polishing trials are completed on the samples without thermal treatments and are continuing on the samples with thermal treatments.

We report here on the results achieved on one of the samples without the thermal treatments, namely the sample #4. Sample #4 was diamond turned achieving representative surface status, in terms of shape accuracy and roughness, with respect to what it's expected on the real size M1 mirror. The shape accuracy of 1030 nm rms and the roughness of 6 nm rms.

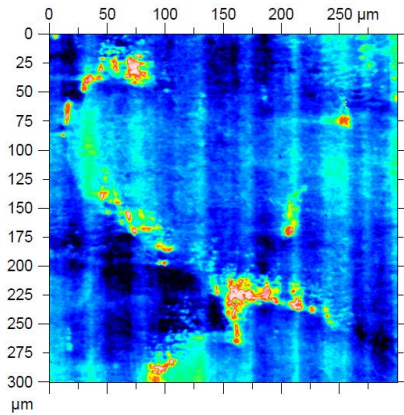

Sample #4

roughness: 6 nm rms

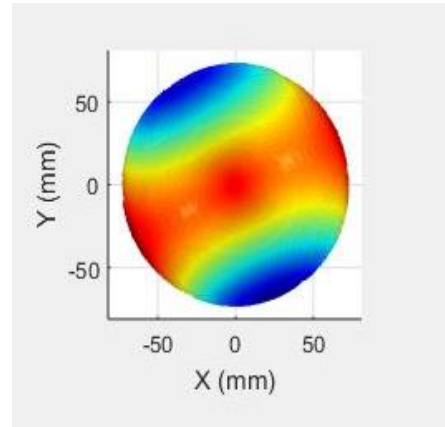

Sample #4

Shape accuracy: 1030 nm rms

Representative roughness and shape measurements of sample #4 after diamond turning and before polishing

Several combinations of polishing slurries, polishing pads and polishing parameters were tested before processing the sample #4. The best and most promising combination is applied to the sample #4 demonstrating that the specification for both shape and roughness are achieved.

The target for the shape accuracy is 80 nm rms, which is far from being achievable by diamond turning only. On the contrary, the target surface roughness of 10 nm rms can be achieved by direct diamond turning. Therefore, the ideal task of the polishing process is to improve the form accuracy of the mirror; maintaining at the same time the roughness within the specification. In reality, to have a sufficient removal rate during the corrective polishing, one should accept a temporary worsening of the surface roughness; with the goal to bring again the roughness within specification once the form correction is achieved.

The first polishing runs on sample #4 are performed with a more aggressive combination, and after 10 runs the shape is improved significantly from 1030 nm rms to 295 nm rms, whilst the roughness is increased from 6 nm rms to 29 nm rms. Reducing then the removal rate, the roughness started to improve and after 21 runs is below the requirement of 10 nm rms. At the same time the shape accuracy continued to improve, up to the final value of 36 nm rms. The total polishing time spent on sample #4 corresponds to 100 hours.

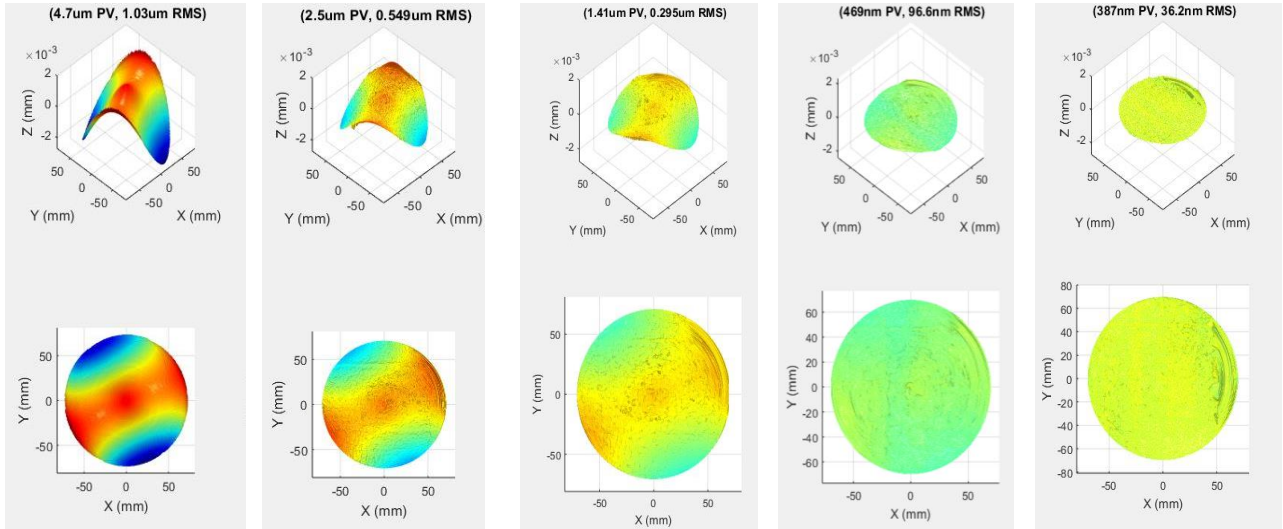

Before polishing	After run #5	After run #10	After run #19	After run #21
Shape: 1030 nm rms	Shape: 549 nm rms	Shape: 295 nm rms	Shape: 97 nm rms	Shape: 36 nm rms
Roughness: 6 nm rms	Roughness: 21 nm rms	Roughness: 29 nm rms	Roughness: 18 nm rms	Roughness: 9 nm rms

1.5 Definition of the shape of the lightening and support structure

Selecting the proper geometry of the honeycomb structure of the M1 is a challenging process. In fact, the ribs have to be arranged in order to minimize the mass and maximizing the stiffness, while keeping the ratio between the front surface thickness and the rib spacing high enough to avoid large deflections when polishing.

The optimization process, fully described in [5], is based on the minimization of the ratio between the first resonant frequency of the mirror and its mass, varying the thicknesses of the front, rib and edge surfaces as three parameters, gave the geometry depicted in Figure 7, in which the main parameters of the structure are the following: main surface thickness = 15 mm, ribs thickness = 7 mm, overall thickness at the center = 60.016 mm, maximum and minimum overall thickness 127.521 mm and 90.489 mm respectively. The mechanical aperture of M1 is 1134.365 by 779.808 mm that correspond to an optical aperture of 1104.357 by 749.808, this because for the polishing a 15 mm of extra edge is necessary to guarantee a good polishing process by the Zeeko machine.

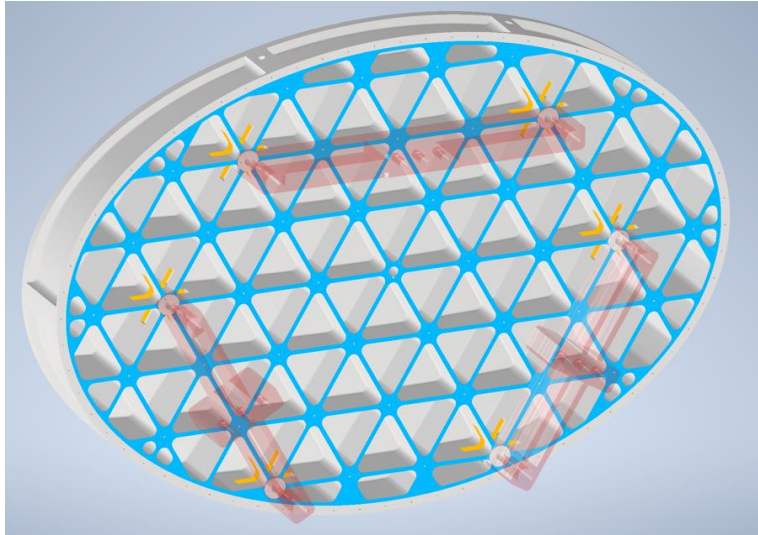

Figure 7 M1 CAD model seen by back side (in light red the working model of the flexures hinges).

The opportunity made available by the use of the BB700 allowed us to highlight a criticality which, if it was well known in terms of quality by the optical manufacturers, was nevertheless not quantified for the production of a large lightened aluminum mirror to be used in space missions. This criticality is the imprint that can be imposed by the mechanical interface with the flexure hinges to the optical surface. Using the same mechanical processing foreseen for M1 also in the BB700, we had the opportunity to measure by interferometric way and then to exactly simulate this effect at an advanced stage of the manufacturing process. This effect is visible in Figure 8 for the simulation and the real measurement for a nominal value of the clamping force between M1 and the flexure hinges.

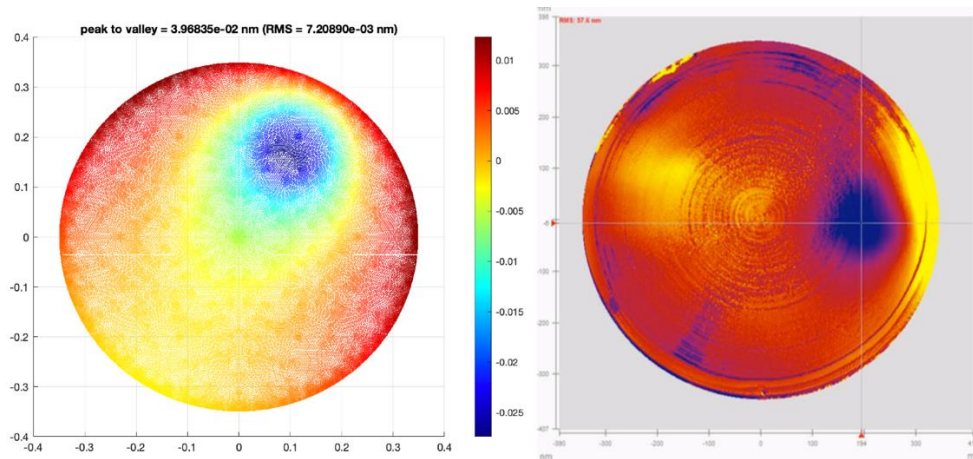

Figure 8 Bump effect related to the mechanical interface: on the right the interferometric measure (58 nm RMS) and on the left the simulation (61 nm RMS) for 8500 N of clamping force (M12 screw).

Following this measure, the team initiated a long series of analyzes and studies to mitigate this effect. Many new geometries of the mechanical interface have been attempted and work is still ongoing, but one strategy seems to be better than the others.

As visible in Figure 9, the problem seems to be related to the deformation energy coming from the clamping force which is transmitted towards the optical surface passing through the structures that support the tightening nut.

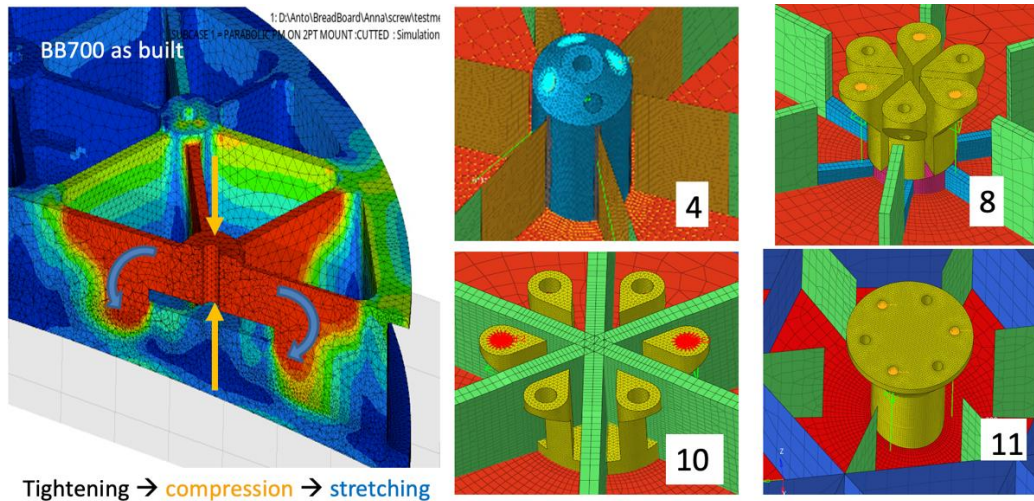

Figure 9 M1 mechanical interface. On the left the mechanical interface as built, on the right some possible solutions

Thus, if the structure is interrupted by a cut or if the volume subject to compression is kept insulated the simulations give us a very better result, rescaling the bump effect by a factor of more than 100. Different solutions are under validation: simulation #4 is particularly interesting because of the direction of the screws. They form an angle with respect the axis of the aluminum rod in which they are: so doing the deformation forces seem to be partially compensated and the bump effect particularly reduced. In particular solutions 4-11 make use of three M8 screws and the total amount of the RMS bump effect scales of 1E-3, resolving completely the problem.

The stiffness of these two solutions has been tested, too: the original first resonance frequency of the original design was 177 Hz, while the new design (solution 4 or 11) reduces this frequency up to 138 Hz, that it is however slightly higher than the minimum admitted value which is 130.

By the way these solutions need to be investigated also by a point of view of stiffness of the entire telescope assembly, activity that is under development.

1.6 Conclusions

ARIEL's primary mirror is clearly one of the most complex components of the entire mission, both for its size and for the requirements of optical quality and mechanical stability. The use of aluminum to create such a structure offers great opportunities in terms of manufacturing, cost and time, but the production and qualification process of such a mirror requires a continuous research and development activity. This because we have not a previous experience available, neither by industry nor by research institutes.

This makes the implementation process a great challenge that the team has decided to accept and carry out together with the involved companies. The preliminary data obtained from the manufacturing process of breadboards and from the processing of samples seem to go in the direction of being able to reach the specifications imposed by the scientific requirements.

However, some critical issues have not yet been resolved despite being under control: in particular I am referring to the mechanical interfacing system of the primary mirror with the underlying mechanical structure of the optical bench and to the polishing process of the final off axis parabola mirror that is M1.

The risk mitigation processes, if on the one hand allow us to proceed more safely, on the other hand they force us to wait long times for results: this makes the process of closing the loop slow, even if effective. I am referring to the thermal processes implemented for the realization of the samples and the two BreadBoards, to the processes for measuring the mechanical parameters of aluminum before and after these processes, their crystallographic study and the fine-tuning of the polishing process on the various samples in order to understand how aluminum changes, for better or for worse, during these processes. This activity has been going on for many months and involves many European research institutes and companies that are operating in unison in an extraordinary way. The mechanical model design process is also completely innovative and requires the use of innovative calculation and validation tools, as well as the preparation of qualification and control processes that are not entirely obvious.

References

- [1] Jan Kinast et al., "Minimizing the bimetallic bending for cryogenic metal optics based on electroless nickel," Proc. SPIE 9151, Advances in Optical and Mechanical Technologies for Telescopes and Instrumentation, 915136 (18 July 2014); doi: 10.1117/12.2056271
- [2] Jan Kinast, et al. "Manufacturing of aluminum mirrors for Cryogenic applications," Proc. SPIE 10706, Advances in Optical and Mechanical Technologies for Telescopes and Instrumentation III, 107063G (10 July 2018); doi: 10.1117/12.2313126
- [3] Raymond G. Ohl IV, et al. "Comparison of stress-relief procedures for cryogenic aluminum mirrors," Proc. SPIE 4822, Cryogenic Optical Systems and Instruments IX, (25 November 2002); doi: 10.1117/12.451762
- [4] ASM Metals HandBook Volume 4 - Heat Treating.
- [5] Del Vecchio et al., proceedings of this conference
- [6] Da Deppo, V., Middleton, K., Focardi, M., Morgante, G., Claudi, R., Pace, E., and Micela, G., "The optical configuration of the telescope for the ARIEL ESA mission," in Space Telescopes and Instrumentation 2018: Optical, Infrared, and Millimeter Wave.
- [7] MacEwen, H. A., Lystrup, M., Fazio, G. G., Batalha, N., Tong, E. C., and Siegler, N., eds., 161, SPIE, Austin, United States (Aug. 2018).
- [8] Sahin, F. E., "Open-source optimization algorithms for optical design," Optik 178, 1016–1022 (Feb. 2019).
- [9] Diolaiti, E., Brucalassi, A., Chioetto, P., Cortecchia, F., Ferruzzi, D., Guerriero, E., Lombini, M., Pascale, E., and Tozzi, A., "Ariel Payload Consortium Phase B2 Payload Study - Telescope Assembly Zemax
- [10] Tozzi, A., Brucalassi, A., Chioetto, P., Pace, E., ARIEL Telescope Assembly Budgets Report (ARIEL-INAF-PL-RP-001)