



<b>Publication Year</b>	2008
<b>Acceptance in OA</b>	2024-06-24T09:03:49Z
<b>Title</b>	CSL Phase Switch Tuning Report
<b>Authors</b>	VILLA, Fabrizio, D'Arcangelo, Ocleto, Lowe, Stuart, TERENCE, LUCA, MENNELLA, ANIELLO, BATTAGLIA, Paola Maria, Franceschet, Cristian, CUTTAIA, FRANCESCO
<b>Handle</b>	<a href="http://hdl.handle.net/20.500.12386/35212">http://hdl.handle.net/20.500.12386/35212</a>
<b>Volume</b>	PL-LFI-PST-RP-038













**TITLE:** **CSL Phase Switch Tuning Report**

**DOC. TYPE:** **Test Report**

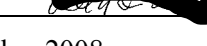
**PROJECT REF.:** **PL-LFI-PST-RP-038**      **PAGE:** **I of IV, 67**

**ISSUE/REV.:** **1.0**      **DATE:** **28<sup>th</sup> July 2008**

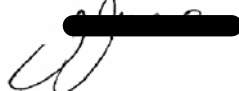
<b>Prepared by</b>	F.VILLA O.D'ARCANGELO S. R. LOWE L. TERENCE A. MENNELLA P. BATTAGLIA C. FRANCESCHET F. CUTTAIA On Behalf of LFI IOT	<b>Date:</b> July , 2008 <b>Signature:</b>        
<b>Checked by</b>	A. GREGORIO LFI AIV Manager	<b>Date:</b> July , 2008 <b>Signature:</b> 
<b>Agreed by</b>	C. BUTLER LFI Program Manager	<b>Date:</b> July , 2008 <b>Signature:</b> 
<b>Approved by</b>	N. MANDOLESI LFI Principal Investigator	<b>Date:</b>  <b>Signature:</b> 







## TABLE OF CONTENTS

<b>1</b>	<b>ACRONYMS .....</b>	<b>1</b>
<b>2</b>	<b>INTRODUCTION.....</b>	<b>2</b>
2.1	PURPOSE AND SCOPE .....	2
2.2	TEST CONFIGURATION.....	2
<b>3</b>	<b>APPLICABLE AND REFERENCE DOCUMENTS.....</b>	<b>3</b>
3.1	APPLICABLE DOCUMENTS.....	3
3.2	REFERENCE DOCUMENTS.....	3
<b>4</b>	<b>INTRODUCTION.....</b>	<b>4</b>
<b>5</b>	<b>TEST RECORD AND TEST DATA .....</b>	<b>5</b>
<b>6</b>	<b>DATA ANALYSIS AND RESULTS .....</b>	<b>9</b>
6.1	FIRST RUN.....	9
6.1.1	<i>RCA24 Contour Plots.....</i>	<i>11</i>
6.1.2	<i>RCA25 Contour Plots.....</i>	<i>14</i>
6.1.3	<i>RCA26 Contour Plots.....</i>	<i>16</i>
6.1.4	<i>RCA27 Contour Plots.....</i>	<i>18</i>
6.1.5	<i>RCA28 Contour Plots.....</i>	<i>22</i>
6.2	SECOND RUN .....	26
6.2.1	<i>RCA24 Contour Plots.....</i>	<i>27</i>
6.2.2	<i>RCA25 Contour Plots.....</i>	<i>30</i>
6.2.3	<i>RCA26 Contour Plots.....</i>	<i>32</i>
6.2.4	<i>RCA27 Contour Plots.....</i>	<i>34</i>
6.2.5	<i>RCA28 Contour Plots.....</i>	<i>38</i>
<b>7</b>	<b>RCA, RAA, CSL AND OTHER QUESTIONS .....</b>	<b>42</b>
7.1	RCA24 CONTOUR PLOTS.....	43
7.2	RCA25 CONTOUR PLOTS.....	47
7.3	RCA26 CONTOUR PLOTS.....	51
7.4	RCA27 CONTOUR PLOTS.....	55
7.5	RCA28 CONTOUR PLOTS.....	59
7.6	COMMENTS .....	63
<b>8</b>	<b>CONCLUSIONS .....</b>	<b>67</b>



## 1 ACRONYMS

AIV	Assembly, Integration, Verification
ASW	Application Software
BEM	Back End Module
BEU	Back End Unit
CCS	Central Check-out System
CDMU	Central Data Management Unit
DAE	Data Acquisition Electronics
DPU	Digital Processing Unit
EGSE	Electrical ground Support Equipment
FEM	Front End Module
I-EGSE	Instrument EGSE
IST	Integrated Satellite Test
OBC	On Board Clock
RAA	Radiometer Array Assembly
REBA	Radiometric Electronic Box Assembly
S/C	Spacecraft
SCOE	Spacecraft Control and Operation System
SPU	Signal Processing Unit
SUSW	Start- Up Software
SVM	Service Module
TBC	To Be Checked
TBW	To Be Written
TC	Telecommand
TM	Telemetry
UFT	Unit Functional Test



## 2 INTRODUCTION

This document has been issued in the frame of ASI contract that has been released for the activities of Planck-LFI Phase E2

### 2.1 Purpose and Scope

This document is a report of the LFI Phase Switch Tuning Verification performed at Centre Spatial de Liegi during the TV / TB campaign. In particular the test phase is the Ph -5-03-b1

### 2.2 Test configuration

The test configuration is the following

SCOS 2 K HPCCS Version 2.0.787

LFI Gateway Version V0R9P1

TQL 3.1.2

LIFE 3.0.4

LFI Personnel involved during the test is:

LFI AIV Manager	Anna Gregorio UniTs <a href="mailto:anna.gregorio@ts.infn.it">anna.gregorio@ts.infn.it</a>
LFI IOT	Ocleto D'arcangelo IFP/CNR <a href="mailto:ocleto@ifp.cnr.it">ocleto@ifp.cnr.it</a> Stuart. R. Lowe, JBO, The Univ. of Manchester, <a href="mailto:S.R.Lowe@manchester.ac.uk">S.R.Lowe@manchester.ac.uk</a>
Calibration Scientist	Fabrizio Villa INAF/IASF-Bo <a href="mailto:villa@iasfbo.inaf.it">villa@iasfbo.inaf.it</a> Luca Terenzi INAF/IASF-Bo <a href="mailto:terenzi@iasfbo.inaf.it">terenzi@iasfbo.inaf.it</a> Aniello Mennella UniMi <a href="mailto:aniello.mennella@fisica.unimi.it">aniello.mennella@fisica.unimi.it</a> Francesco Cuttaia INAF/IASF-Bo <a href="mailto:cuttaia@iasfbo.inaf.it">cuttaia@iasfbo.inaf.it</a>
Industry support	Paola Battaglia TAS-I, <a href="mailto:paola.battaglia@thalesalieniaspace.com">paola.battaglia@thalesalieniaspace.com</a> Christian Franceschet TAS-I, <a href="mailto:christian.franceschet@thalesalieniaspace.com">christian.franceschet@thalesalieniaspace.com</a>

Lowe, S.R. Jodrell Bank Centre for Astrophysics, Alan Turing Building, The University of Manchester, Manchester, M13 9PL, UK



### 3 APPLICABLE AND REFERENCE DOCUMENTS

#### 3.1 Applicable Documents

- [AD1] Herschel/Planck Instrument Interface document Part A  
SCI-PT-IIDA-04624 Issue 3.3
- [AD2] Herschel/Planck Instrument Interface document Part B  
SCI-PT-IIDB-04142 Issue 3.1
- [AD3] Herschel/Planck Instrument Interface document Part B  
SCI-PT-IIDB-04142 Issue 3.1, Annex 3, ICD 750800115
- [AD4] Herschel/Planck Instrument Interface document Part A  
SCI-PT-IIDA-04624 Issue 3.3 Annex 10
- [AD5] TV Tests: LFI Test Under Cryogenic Vacuum, PL-LFI-PST-PR-021 2.2

#### 3.2 Reference Documents

- [RD1] Planck Instrument Testing at PFM S/C levels  
H-P-3-ASP-TN-0676, Issue 1.0
- [RD2] Planck LFI User Manual  
PL-LFI-PST-MA-001 Issue 2.1
- [RD3] LFI Warm Functional Test Procedure (WFT)  
PL-LFI-PST-PR-017\_2\_1
- [RD4] Combined LFI EMC Tests at System Level  
PL-LFI-PST-PR-020
- [RD5] Proposal for LFI test dedicated to characterize New Spikes in the FFT spectrum of Scientific Data  
PL-LFI-PST-TN-080
- [RD 6] F. Villa, Planck LFI tv test @ CSL: phase switch matrix tuning guide, 2<sup>nd</sup> July



## 4 INTRODUCTION

The tuning of PS is performed by varying the PS current supply (I1 and I2) in order to reach the best working condition, i.e. when the SKY-REF output difference is as close as possible to zero when one amplifier at time is switched on. In this condition (see *Figure 1*) the input signal at the phase switch,  $S_{ps}^{in}$ , is a linear combination of sky and ref signal as follows:

$$S_{ps}^{in} \propto G_{FEM} \left( N_{FEM} + \frac{S_{sky} + S_{REF}}{\sqrt{2}} \right)$$

It is the same signal entering the PS as in the case of nominal condition (apart from mismatch differences at the front hybrid since the amplifier is in a different status).

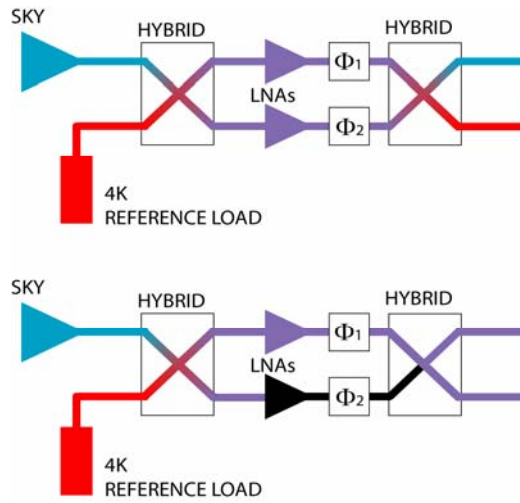

*Figure 1: Radiometer scheme showing the PS tuning. In the upper figure the radiometer is working in a nominal ddcondition and the REF and SKY signal are disentangled at the 2nd hybrid output (then they will be amplified and detected by the BEM). The figure is a shot of a 1/8000 sec. The bottom figure is the case when one amplifier is switched off. Under this condition the output of both hybrid output arms experience the same signal unless the phase switches is not well balanced.*

When a ACA is switched off the SKY and REF signal are no longer identified at the output diodes of BEM. In this case the odd and even samples (4KHz switched on) must show the same signal if the phase switch is well tuned:

$$S_{even}^{bem} \propto \frac{1}{\sqrt{2}} \sqrt{A_2} \cdot e^{i\theta_2} \cdot G_{FEM} \left( N_{FEM} + \frac{S_{sky} + S_{REF}}{\sqrt{2}} \right)$$

$$S_{odd}^{bem} \propto \frac{1}{\sqrt{2}} \sqrt{A_1} \cdot e^{i\theta_1} \cdot G_{FEM} \left( N_{FEM} + \frac{S_{sky} + S_{REF}}{\sqrt{2}} \right)$$

according to Seiffert et al. 2002 page 1187.

It should be noted that the differenced output is null as the two state of the phase switches exhibit the same insertion loss A1 and A2 at a given I1 and I2 pair. When one detector is balanced, the other coupled detector output is balanced as well.



## 5 TEST RECORD AND TEST DATA

Here the test record as reported in LFIwiki at

<http://belzebu.lambrate.inaf.it/twiki/bin/view/LFI/CSLTestRecord>

Only phase switch tuning relevant tests have been reported in table. In summary the phase switch tuning was started on 6<sup>th</sup> July at 22:46 and nominally ended on 7<sup>th</sup> July at 16:27. In this period the procedure script failed on TUN\_0050. The saturation of RCA28 was observed in TUN\_0053 and TUN\_0054. These tests were not used to tune the ACA, so that the RCA28 phase switch tuning was repeated from 10<sup>th</sup> July at 19:13 to 11<sup>th</sup> July 18:10. After several procedure errors, finally the RCA28 was tuned and recorded on TUN\_0066

Time	Test ID	End Time	Test Log
2008/07/06 22:46	TUN_0050	00:14	Phase Switch tuning begins RCA24 M2 and RCA25 M1 are off. 23:06 LFI RCA24 M1 too high as first point is 296!. 23:10 Anna has gone to the control room (CCS). 23:18 I1 set to nominal values. 23:21 nominal values checked. 23:23 procedure re-started. 23:39 there is a long gap waiting for the next I1 value (and cycle of I2) to begin. 23:56 reached the last I2 cycle over I1 but I1 value incremented beyond 255 rather than reset to 205. The test has been suspended as we try to work out what went wrong
2008/07/07 00:16	TUN_0051	03:34	Restart of the phase switch tuning after the fault in the procedure on the previous test. 00:41 the TQL is quite slow to update; it updates the displays with a minute of HK data every minute. Science data does not have the same issue. 01:35 End of RCA24 M/ RCA25 M matrix cycles. 01:45 large change in I1/I2 values to nominal values. 01:54 second leg starts. 02:32 Long wait between RCA24 S1 124 -> 134 and RCA25 S2 159 -> 169. 02:48 last arm started. 02:52 noticed a strange effect in R0 channel science data probably just before the current arm I1 and I2 biases. The science data seems to oscillate between two values. 03:18 some steps in science data are not simultaneous. 03:23 end of RCA24/RCA25 phase switch tuning steps. 03:31 RCA24 S2 and RCA25 S1 are not at their nominal values.
2008/07/07 03:31	TUN_0052	06:18	03:40 biases back to nominal. 04:21 End of first leg. 04:24 second leg started. 05:00 waiting for first leg to begin. 05:35 RCA26 S2 and RCA27 S1 matrix tuning starts. 06:12 End of matrix tuning for RCA26 and RCA27.
2008/07/07 06:19	TUN_0053	09:42	06:32 it appears that the I2 value on RCA28 M2 began at the wrong value. 06:40 Ocleto travelled back in time with the SCOS and discovered that I2 did begin at the correct value but it seems TQL omitted to display them. Saturation of LFI28 was observed when M1 was switched on (and M2 was already on) at the end of the M-arm tuning.



Time	Test ID	End Time	Test Log
2008/07/07 10:20	TUN_0054	16:27	The RCA28 is saturating on all channels. The drain currents are M1=18.6, M2 = 18.6, S1=10.2, S2=11.3. No ACA tuning has been done within this test.
2008/07/10 19:13	TUN_0061	19:38	RCA28 phase switch tuning repetition. Error in the procedure. All channels are on instead of having M2 on and M1 off.
2008/07/10 19:40	TUN_0062	21:00	M2 off. Then M2 is switched on again in "soft mode" (but M1 has not been off). 19:58 M2, M1 off. Phase switch tuning starts. 20:02 Soft switch on of RCA28. 20:06 Soft switch on of RCA28 completed. 20:08 M1 switch off - start tuning M2. 21:00 procedure error. Close TQL session.
2008/07/10 21:05	TUN_0063	21:55	Another error in the procedure. TQL session stopped.
2008/07/10 22:00	TUN_0064	02:00	01:00 Test started. 01:35 M2 off. 02:00 once again an error in the procedure.
2008/07/11 02:05	TUN_0065	10:05	Phase switch tuning delayed. RCA will remain in nominal condition.
2008/07/11 15:24	TUN_0066	18:10	RCA28 phase switch tuning. Start with RCA28 already on. First step is M1 off. 16:00 M2 off and soft on procedure. 16:15 M2 matrix started. 16:47 M1 off (soft switch on). 17:00 S1 off. S2 matrix started. 17:33 S2 off. 17:35 S1 matrix started. 18:00 in the last step we observe that I1=147 when I2 was still at 222 instead of 162.

The test data useful for data analysis is reported in the following table which includes also the time window of the test, relevant for data analysis.

RCA ID	Test ID	Time start	Time end
RCA24	TUN_0051		
RCA25	TUN_0051		
RCA26	TUN_0052		
RCA27	TUN_0052		
RCA28	TUN_0066		

(\*) End time coincides with end of the test.

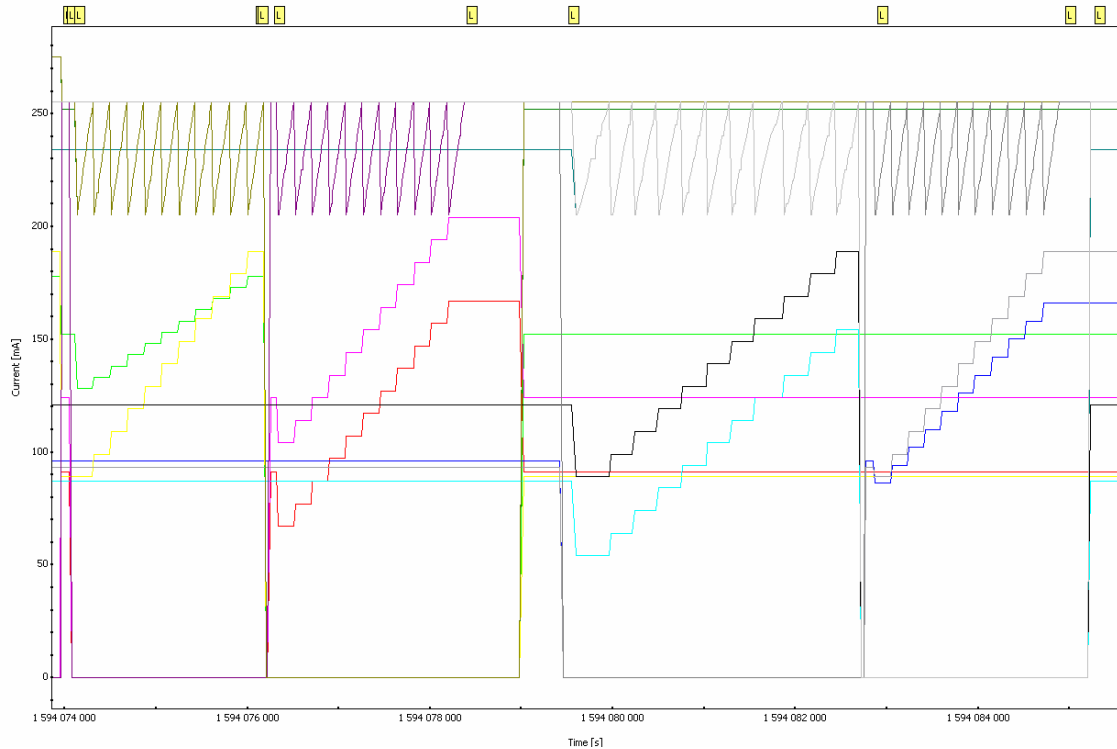

Figure 2: Lama\_view graphical display of the whole TUN\_0051 test

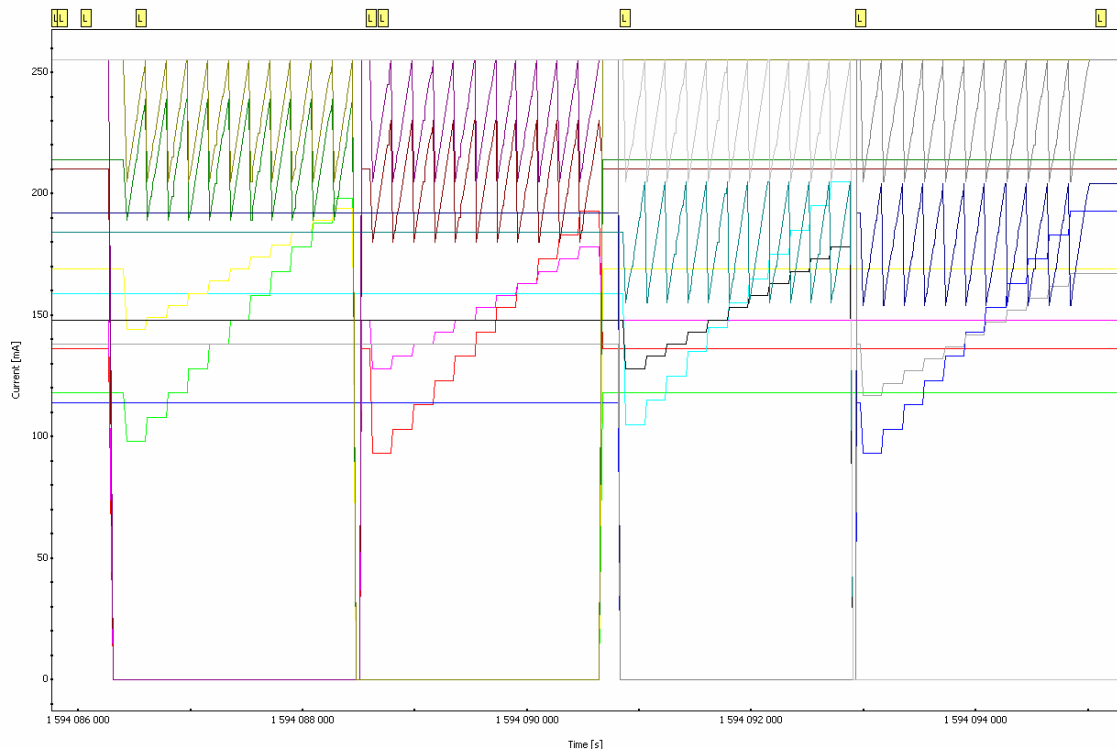

Figure 3: Lama\_view graphical display of the whole TUN\_0052 test

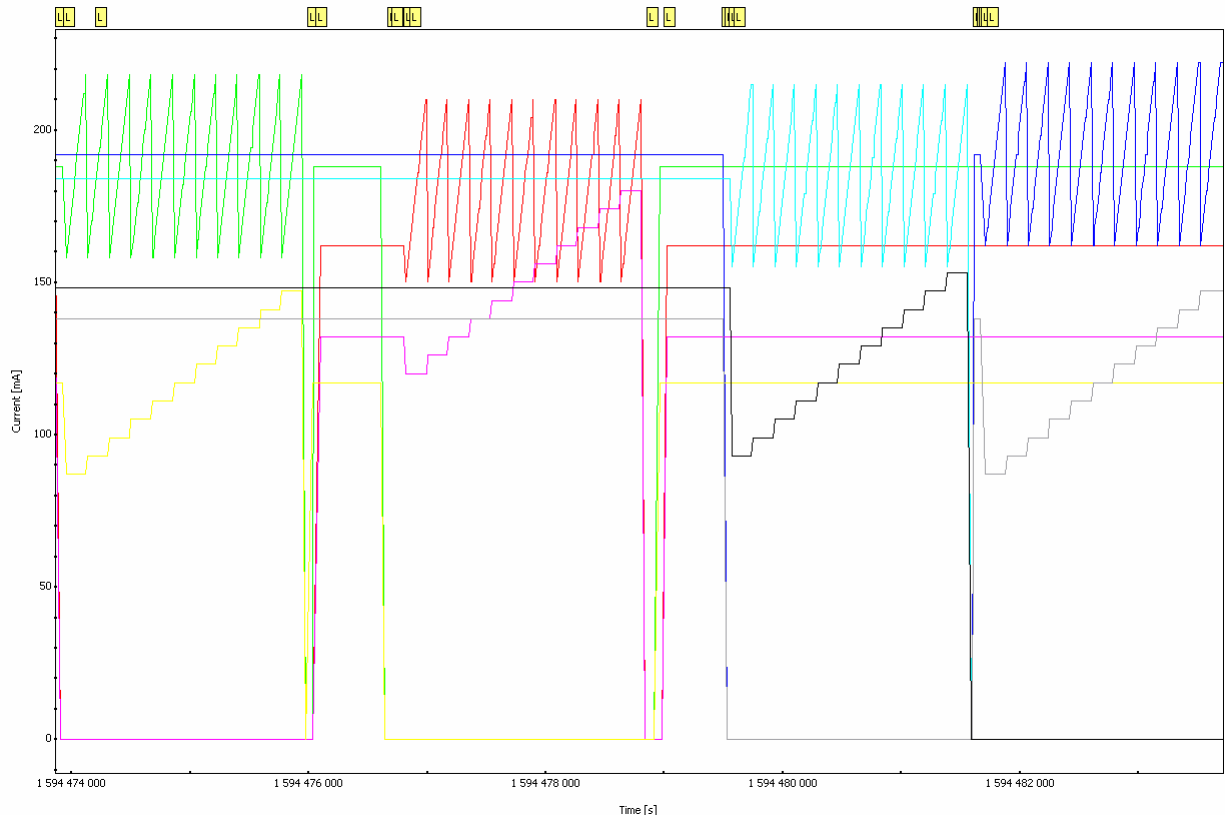





Figure 4: Lama\_view graphical display of the whole TUN\_0066 test



## 6 DATA ANALYSIS AND RESULTS

Data analysis has been performed using dedicated routines within the `LIFE_OM` environment. Specifically the following IDL programs have been used (only relevant programs for this test are listed):

 lama_tune_phase_switch_currents_csl.pro	Main program to identify the House keeping parameter, extract scientific data, perform calculation and send to output the data structure
 select_matrix_tuning_jump.pro	Main program to identify time windows in data fits files as the housekeeping parameters changes
 csl_psw_script.pro	Script to run the above programs, save data in external files and plot results

All these programs are under CVS and distributed with the `LIFE_OM` packages. Obviously the script can be changes as needed.

In section 6.1 the data analysis performed at CSL – Liegi is reported and results of this analysis have been used to decide the best ACA phase switch currents to bias the 30 and 44 ACA for the next tests.

In section 6.2 a further analysis has been performed with particular emphasis on the comparison between the CSL results and previous RCA and RAA results. A critical analysis has been appointed.

### 6.1 FIRST RUN

A first run of data analysis was performed at CSL – Liegi to provide the best tuned biases for next level tests (ACA tuning). This analysis, mainly based on automatic routine `lama_tune_phase_switch_currents_csl.pro` (revision 1.2) suffered from spurious  $I_1$ ,  $I_2$  values (i.e. values not part of the grid) due to test procedure sequence and switching on and off of ACA. In figure *Figure 5* a typical contour plot is shown where also the point  $I_1=0$  and  $I_2=0$  has been accounted. In addition the last point of the grid (top – right) shows a wrong level due to the procedure adopted to conduct the test. Actually the scientific data of the last point is averaged over a time windows that includes also changes in amplifier biases, even if both  $I_1$  and  $I_2$  remain constant. It is stressed here that Both such ‘problems’ in data analysis are not due to an error on the lama routines, since can be avoid by appropriate selection of the time windows that unfortunately cannot be automatic.

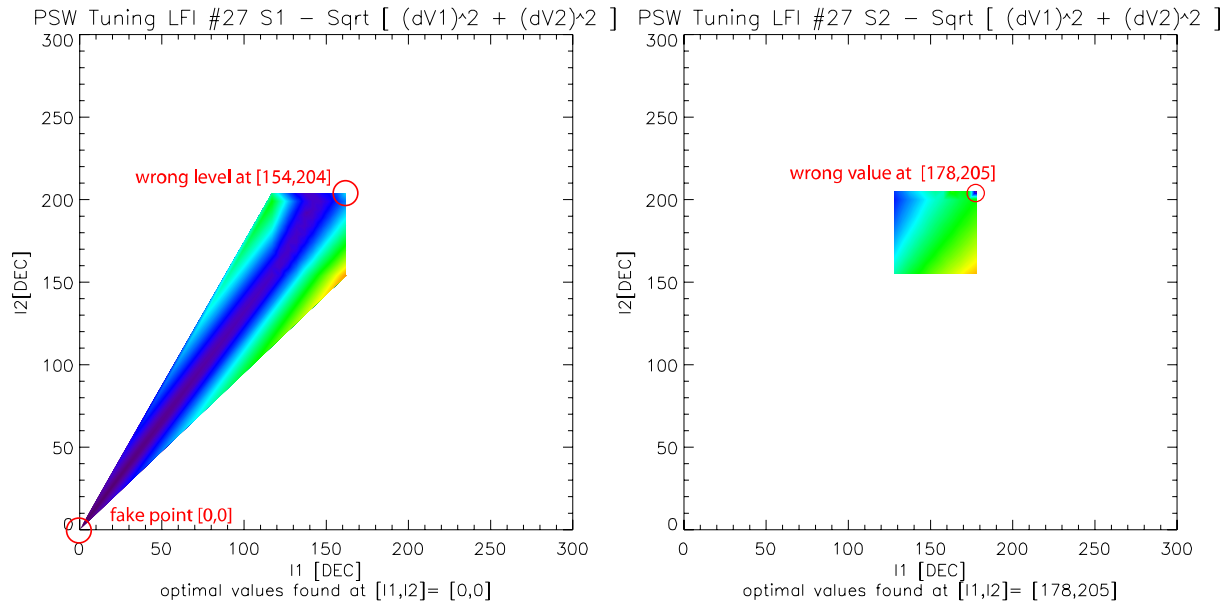

Figure 5: Typical contour plot of the phase switch tuning. Here the plot is “as it is” from the automatic routine. In some cases fake points appear (left plot) together with points with a wrong signal level (right plot)

It has been decided by the IOT to evaluate also the goodness of the results by analysing the data directly with `lama_view`. The final results are reported in *Table 1*.

Table 1: Bias Values as derived from the test and used for the continuation of the CSL campaign

	M1		M2		S1		S2		PSW optimal configuration	
	I1	I2	I1	I2	I1	I2	I1	I2	Switching	Position not switching
#24	128	250	91	255	84	235	86	215	A/C (M2/S2)	(0/0 – I2/I2)
#25	174	235	89	250	93	255	119	225	A/C (M1/S1)	(0/0 – I2/I2)
#26	98	245	153	210	135	230	93	230	B/D (M1/S1)	(0/0 – I2/I2)
#27	178	180	144(*)	214(*)	138	192	128(*)	200(*)	B/D (M2/S2)	(0/0 – I2/I2)
#28	132	162	117	188	111	168	99	173	A/C (M1/S1)	(0/0 – I2/I2)
Red	Scientific tracks never overlap									
Blue	Overlapping occurs, minimum reasonable									
Violet	Overlapping marginal									
(*)	Data chosen manually									

The values in the table above have been superimposed to the contour plot only cleaned by values outside the grid defined for the tuning.



### 6.1.1 RCA24 Contour Plots

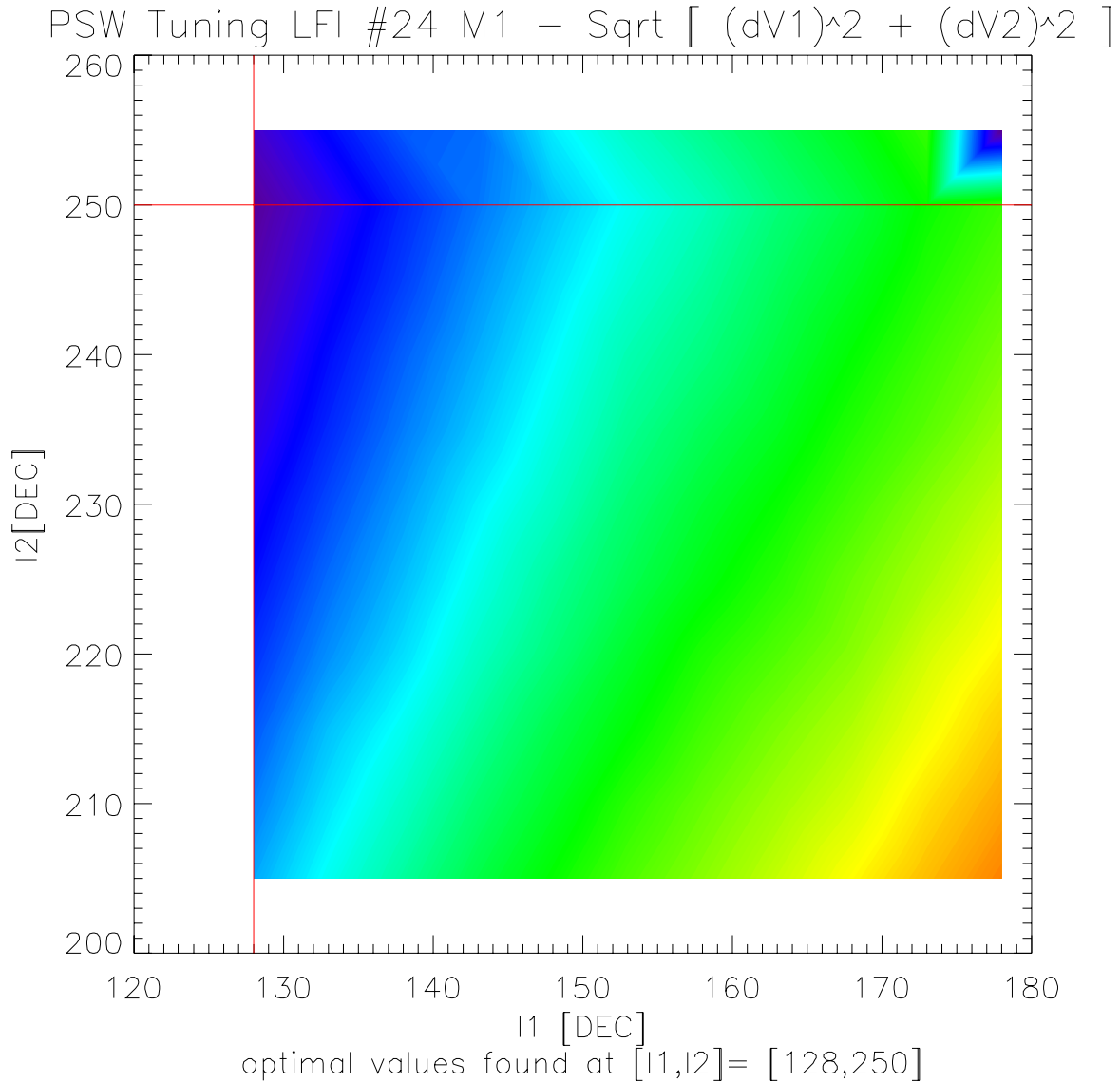

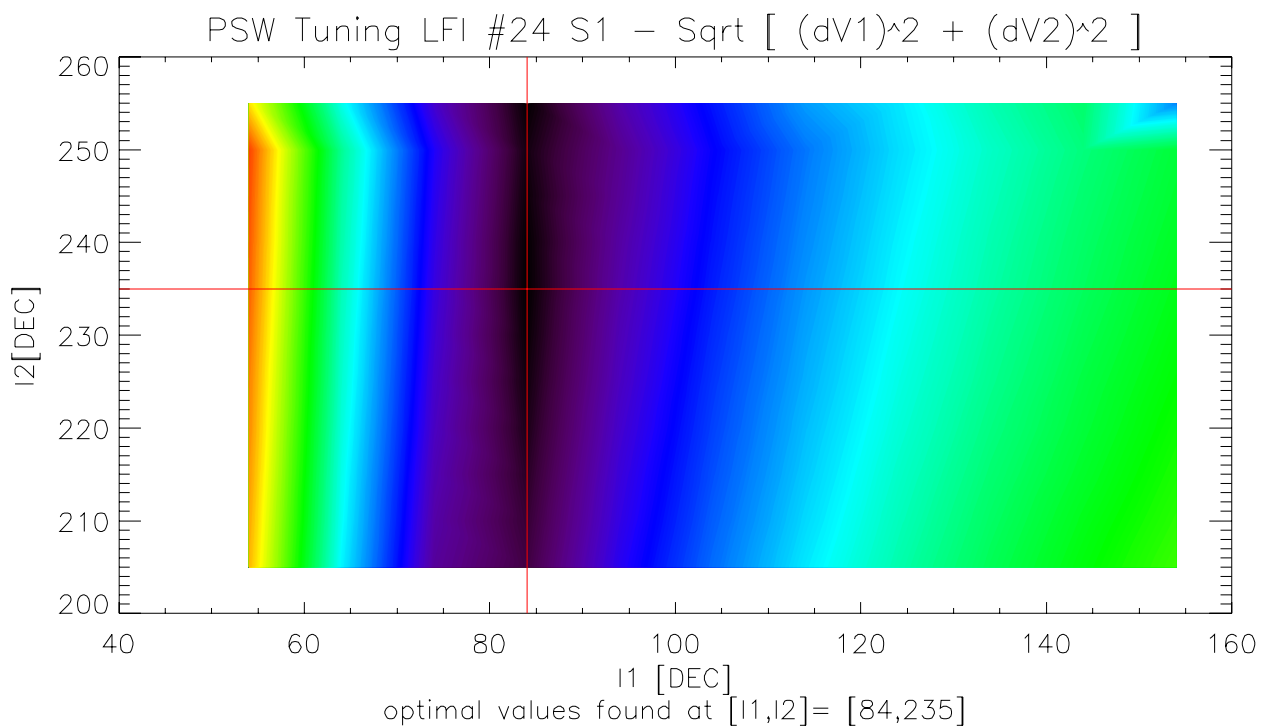
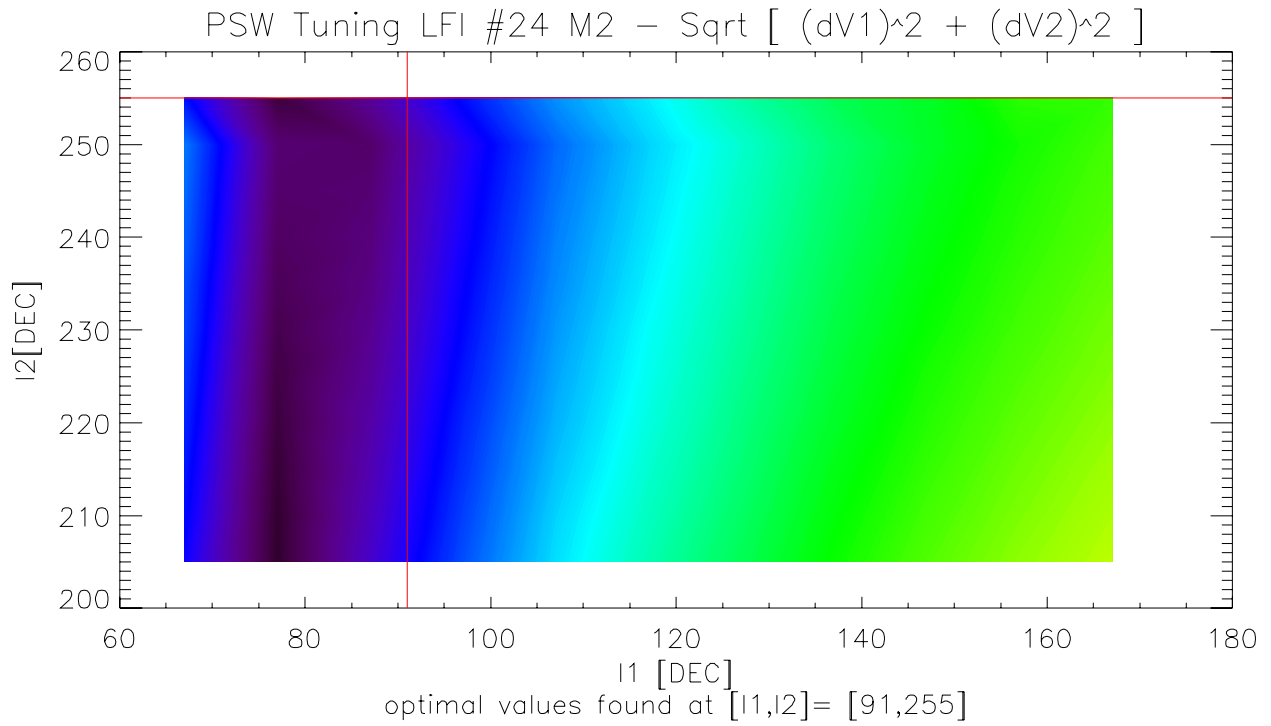

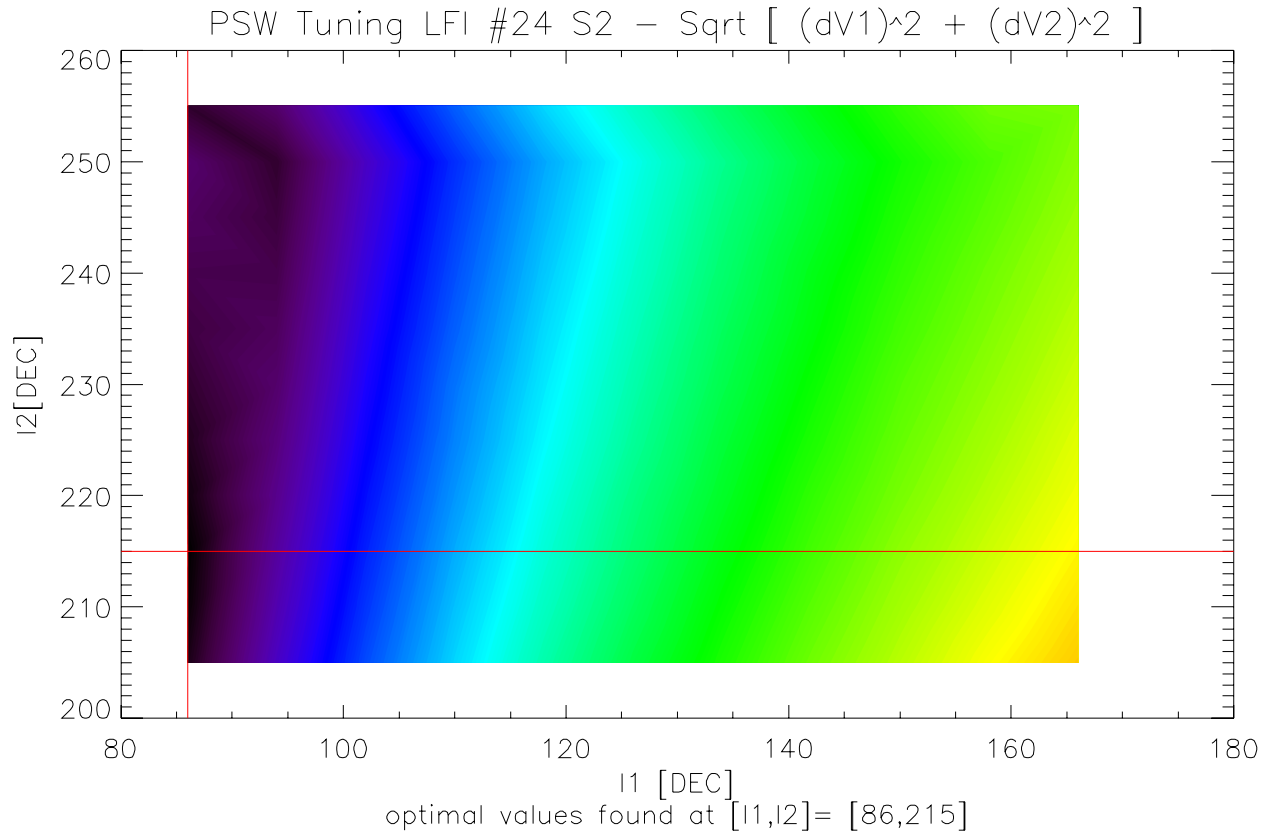



### 6.1.2 RCA25 Contour Plots

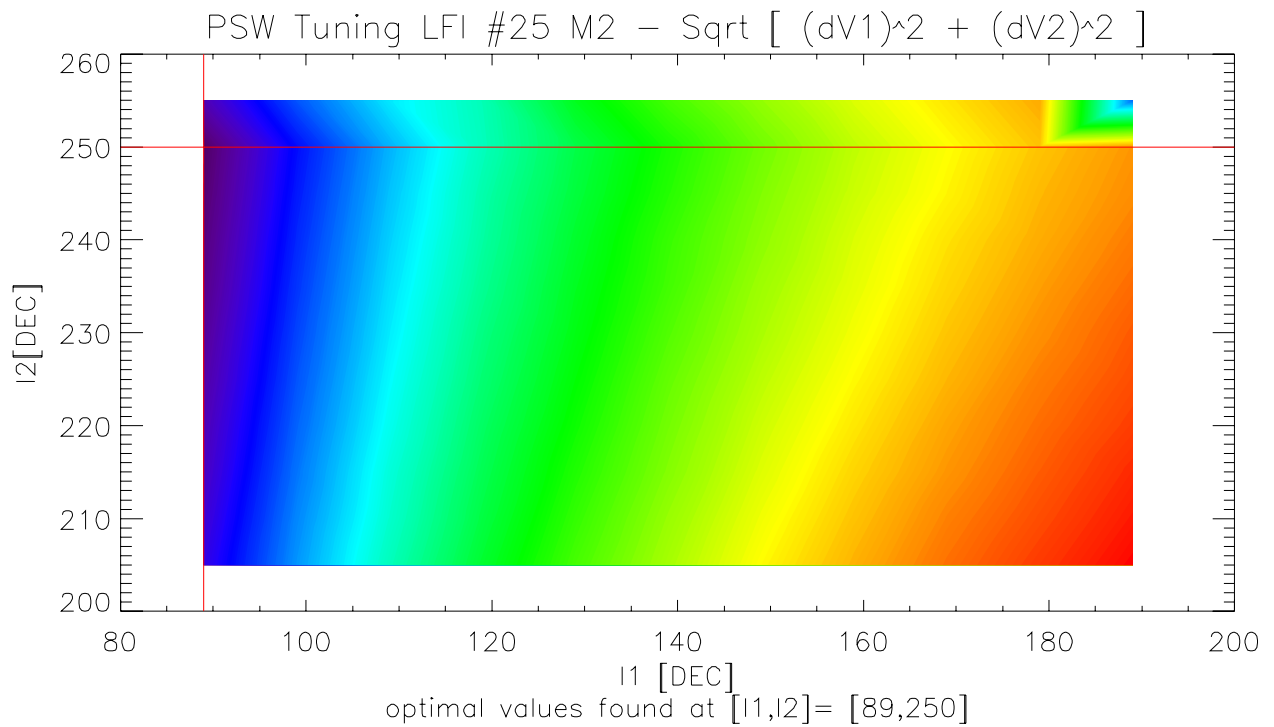
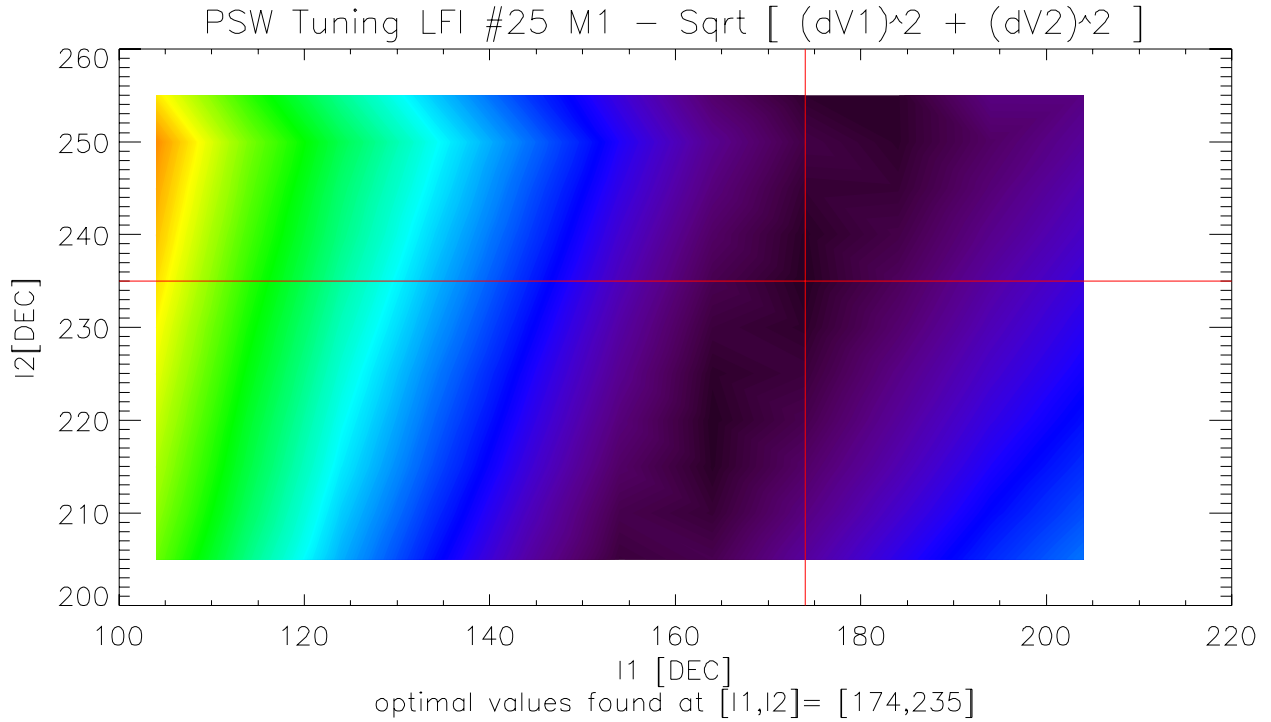

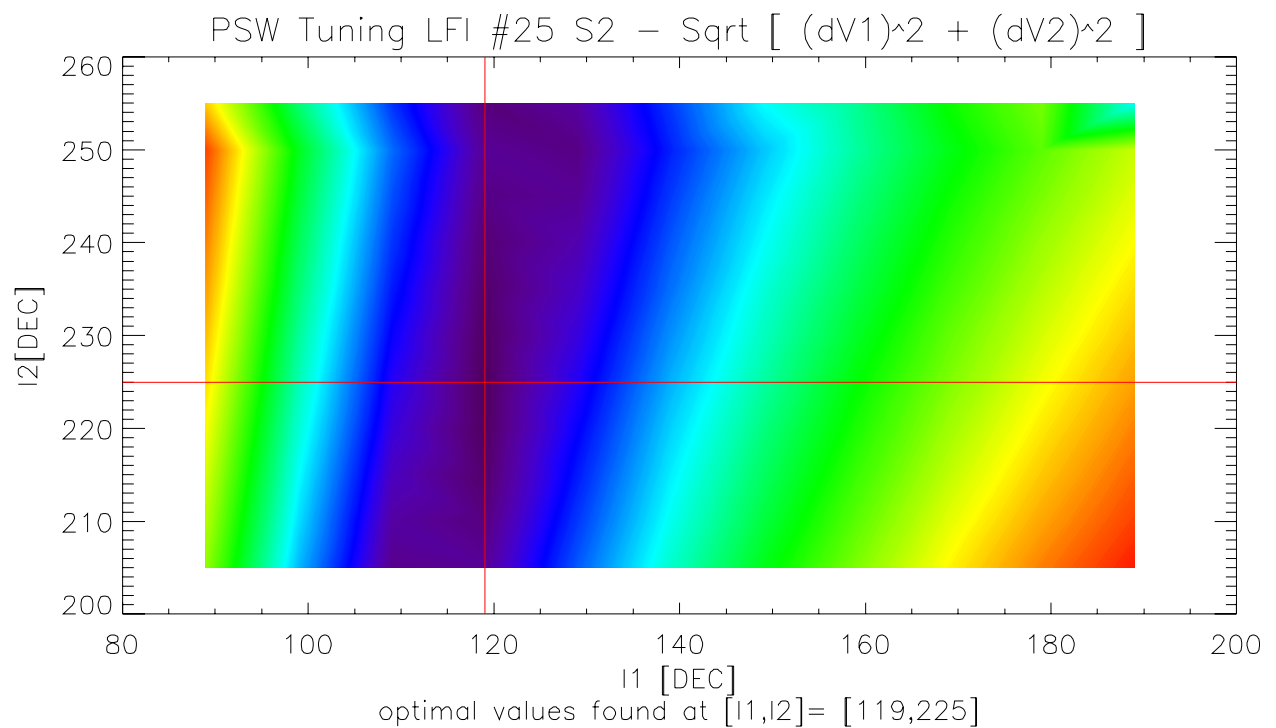
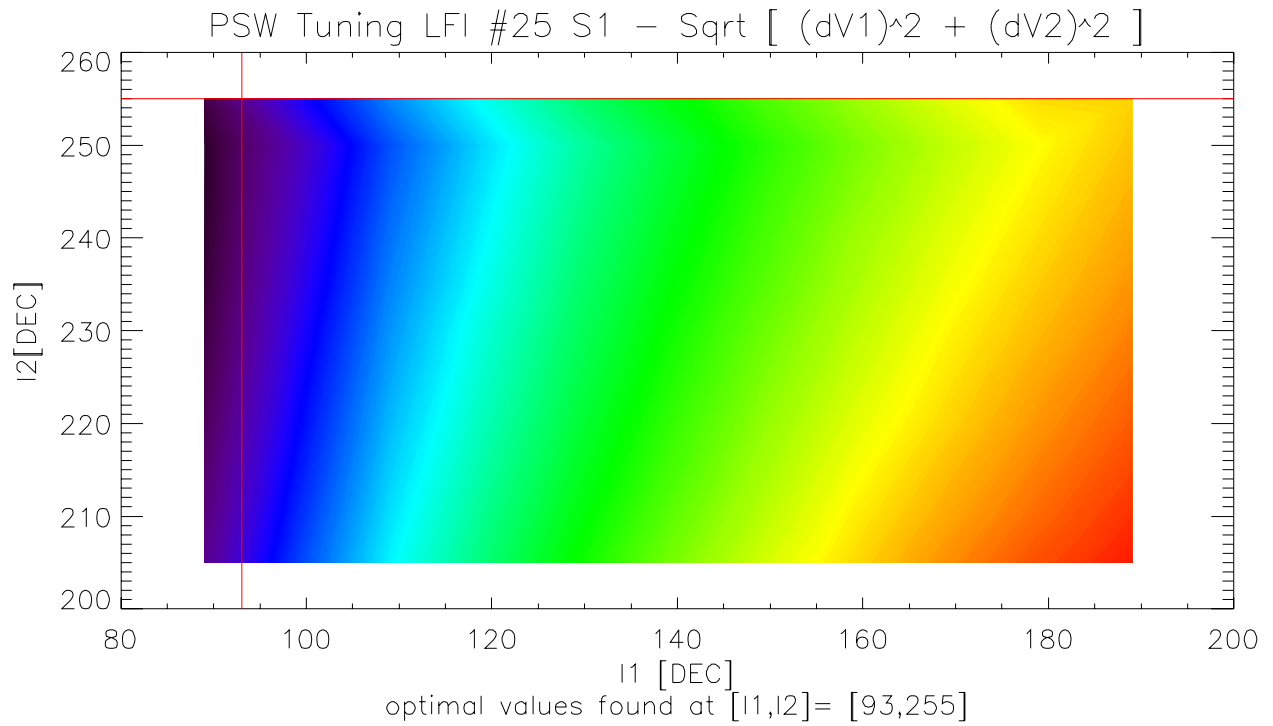



### 6.1.3 RCA26 Contour Plots

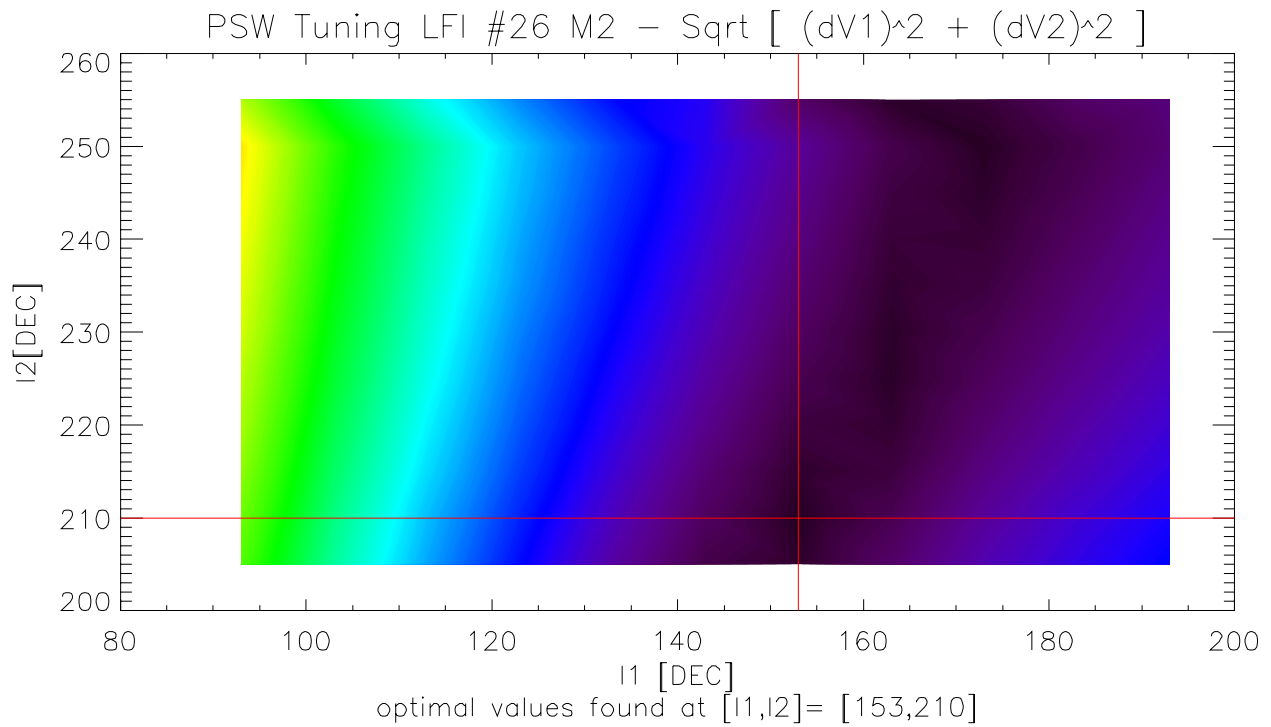
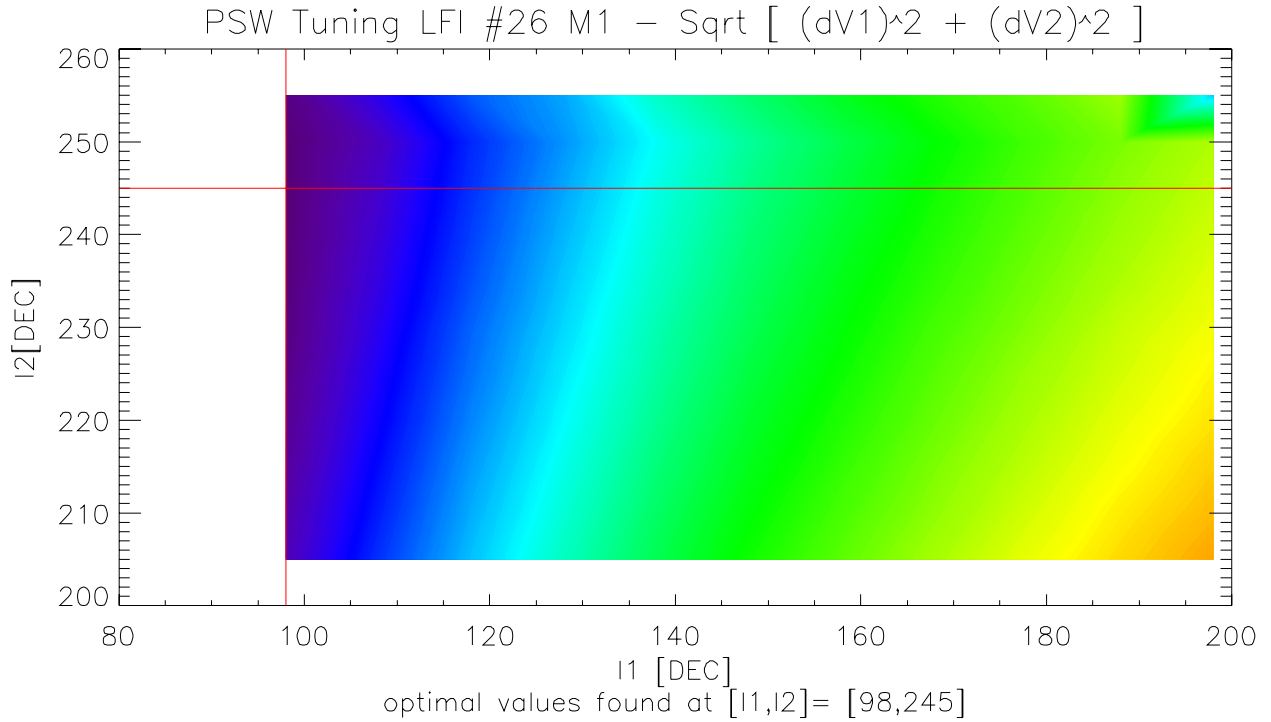

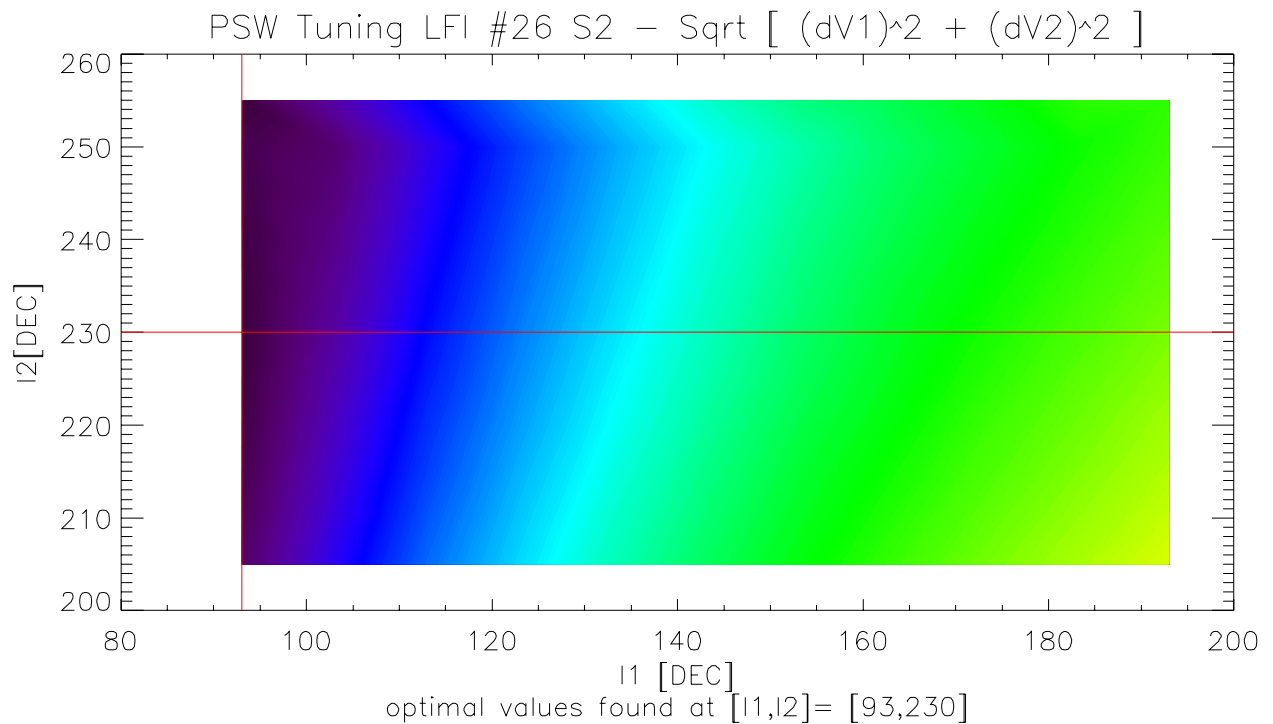
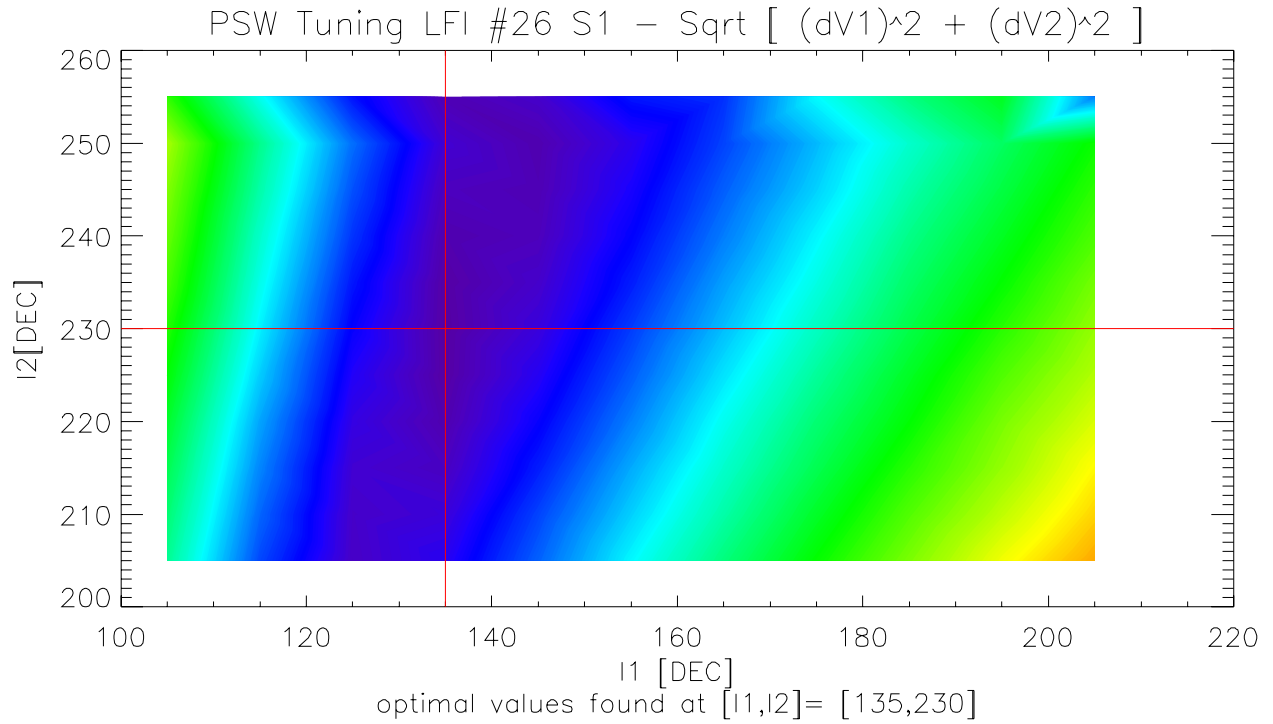



### 6.1.4 RCA27 Contour Plots

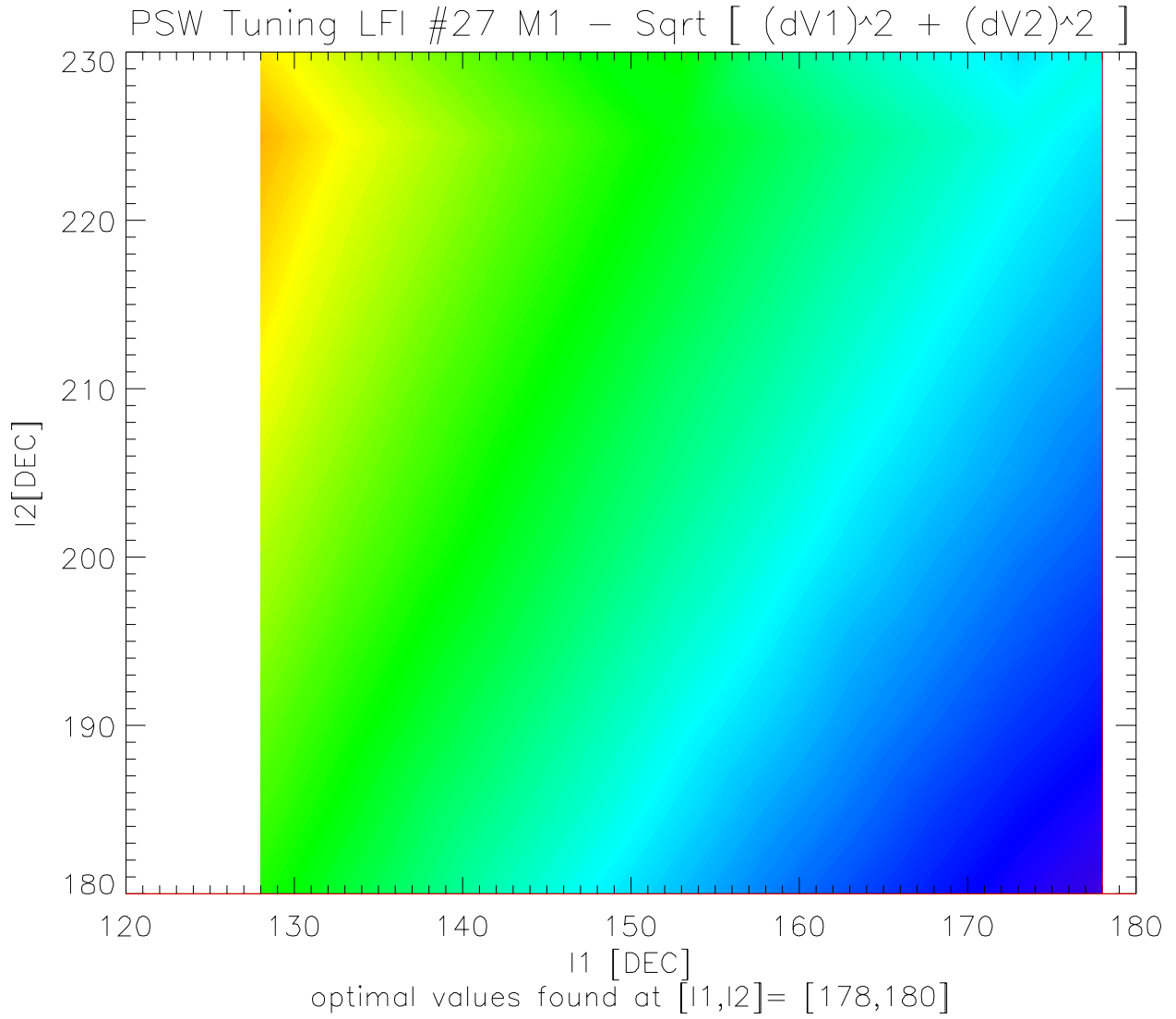

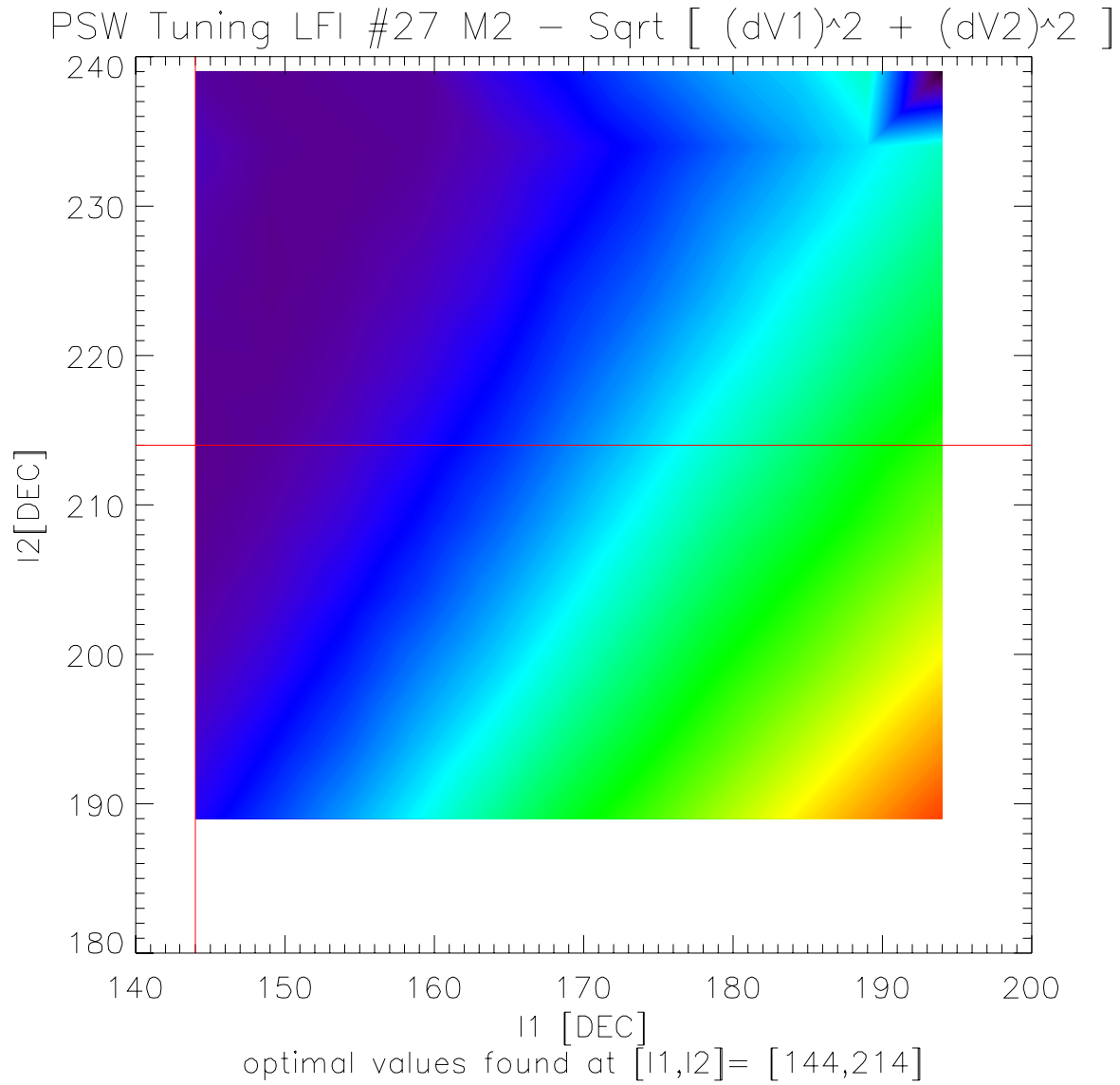

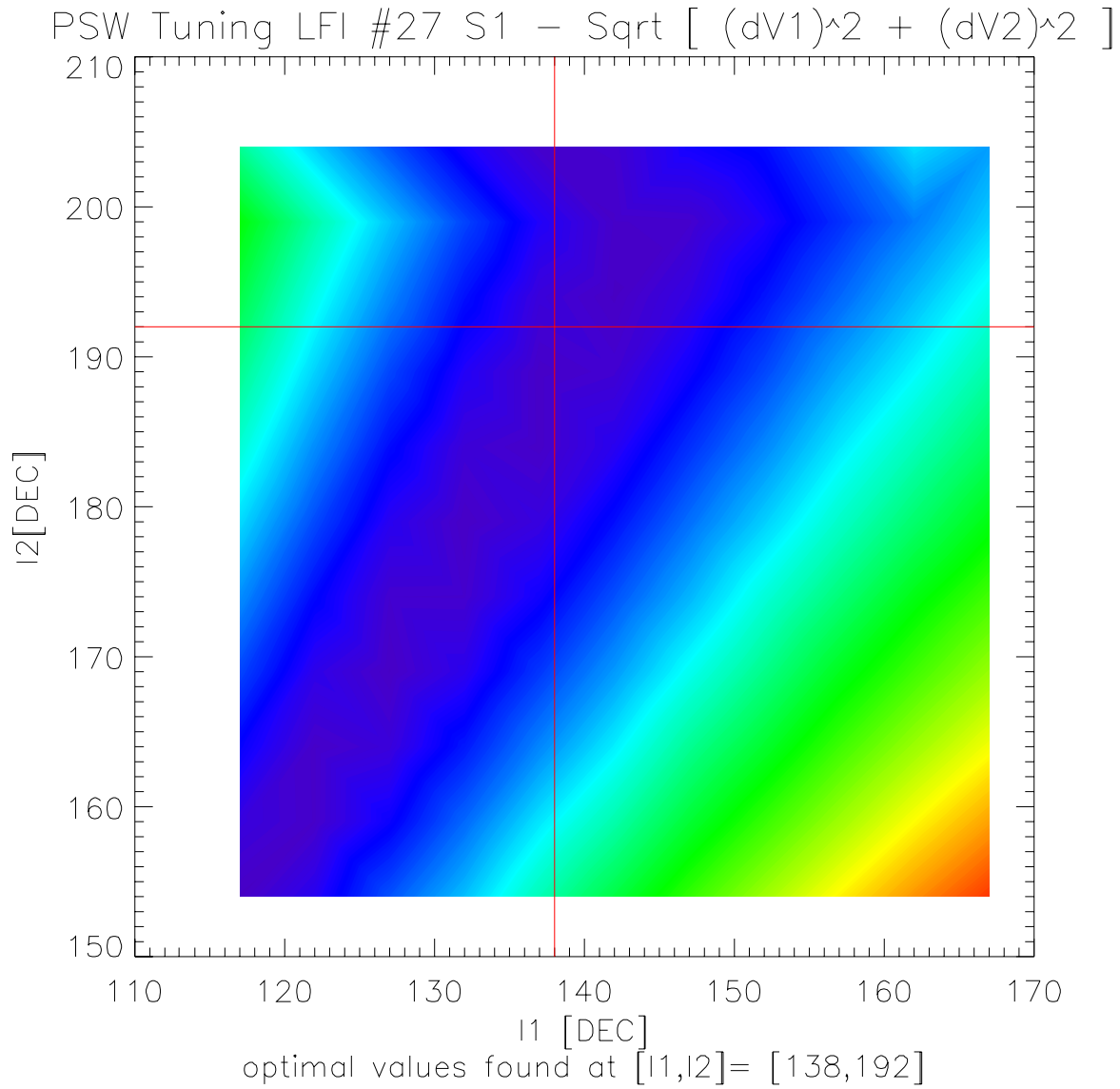

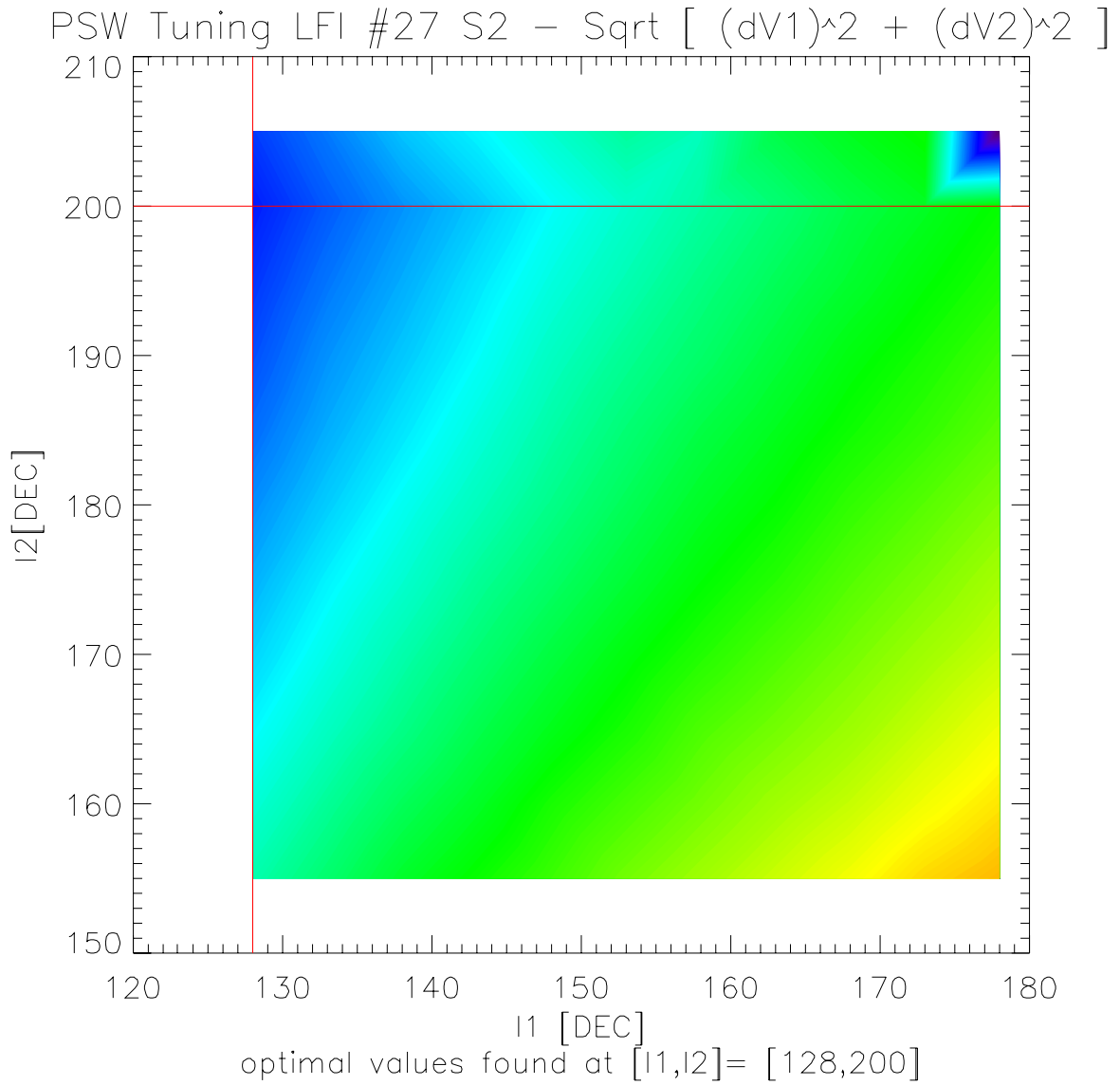



### 6.1.5 RCA28 Contour Plots

PSW Tuning LFI #28 M1 -  $\text{Sqrt} [ (dV1)^2 + (dV2)^2 ]$

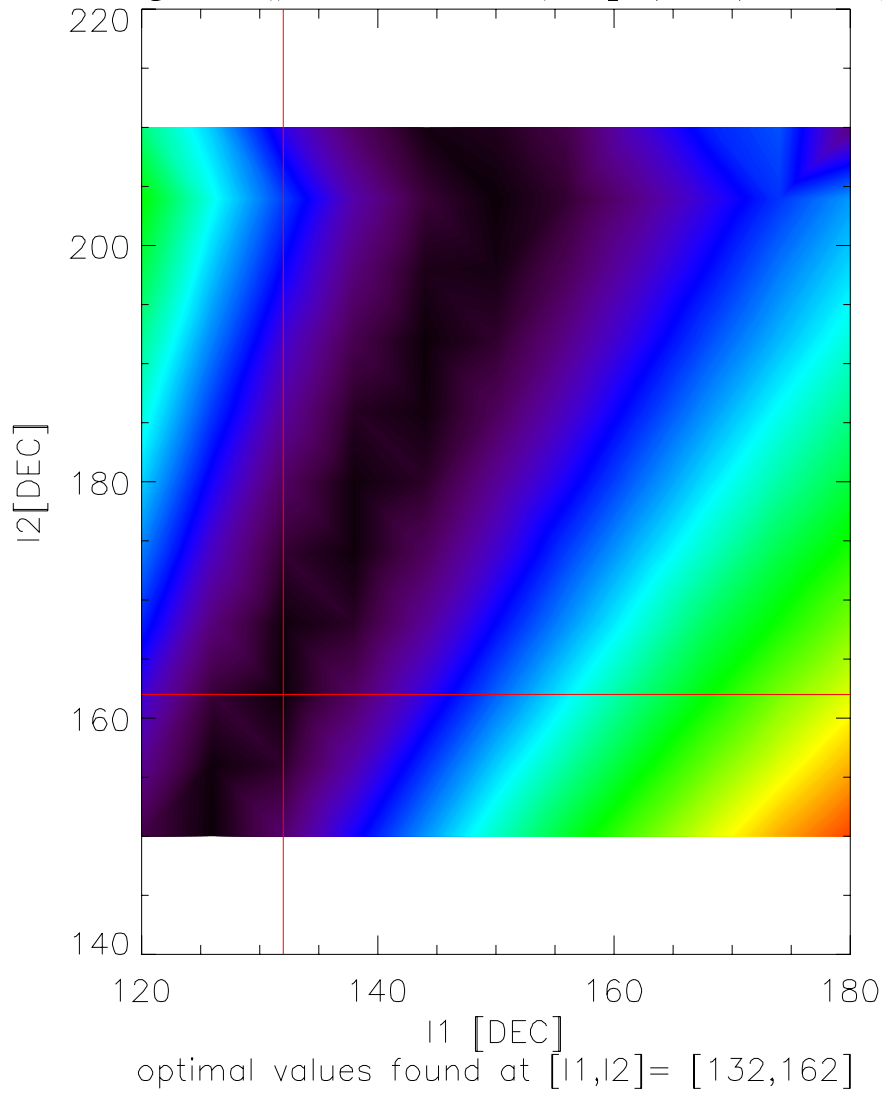

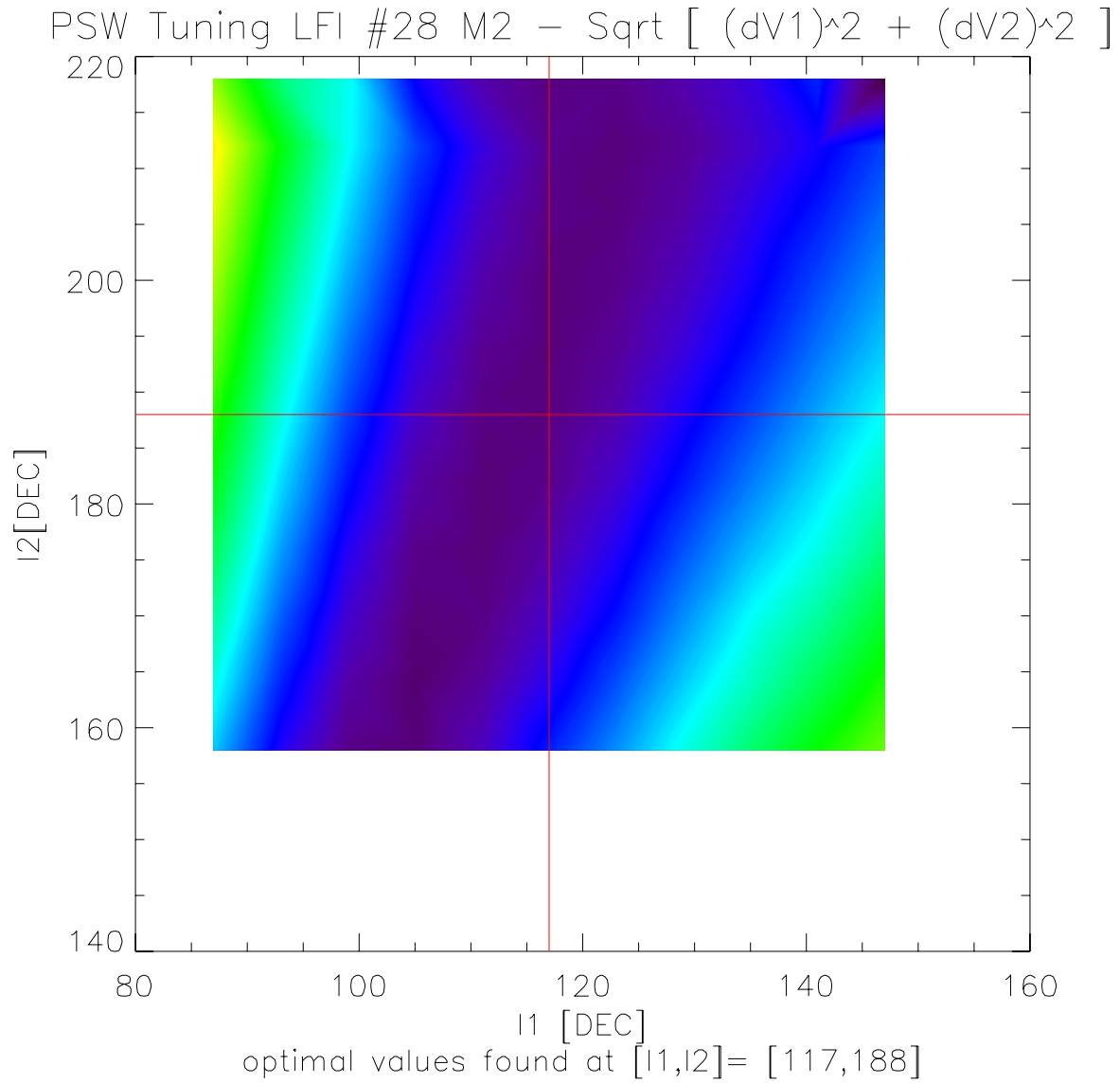

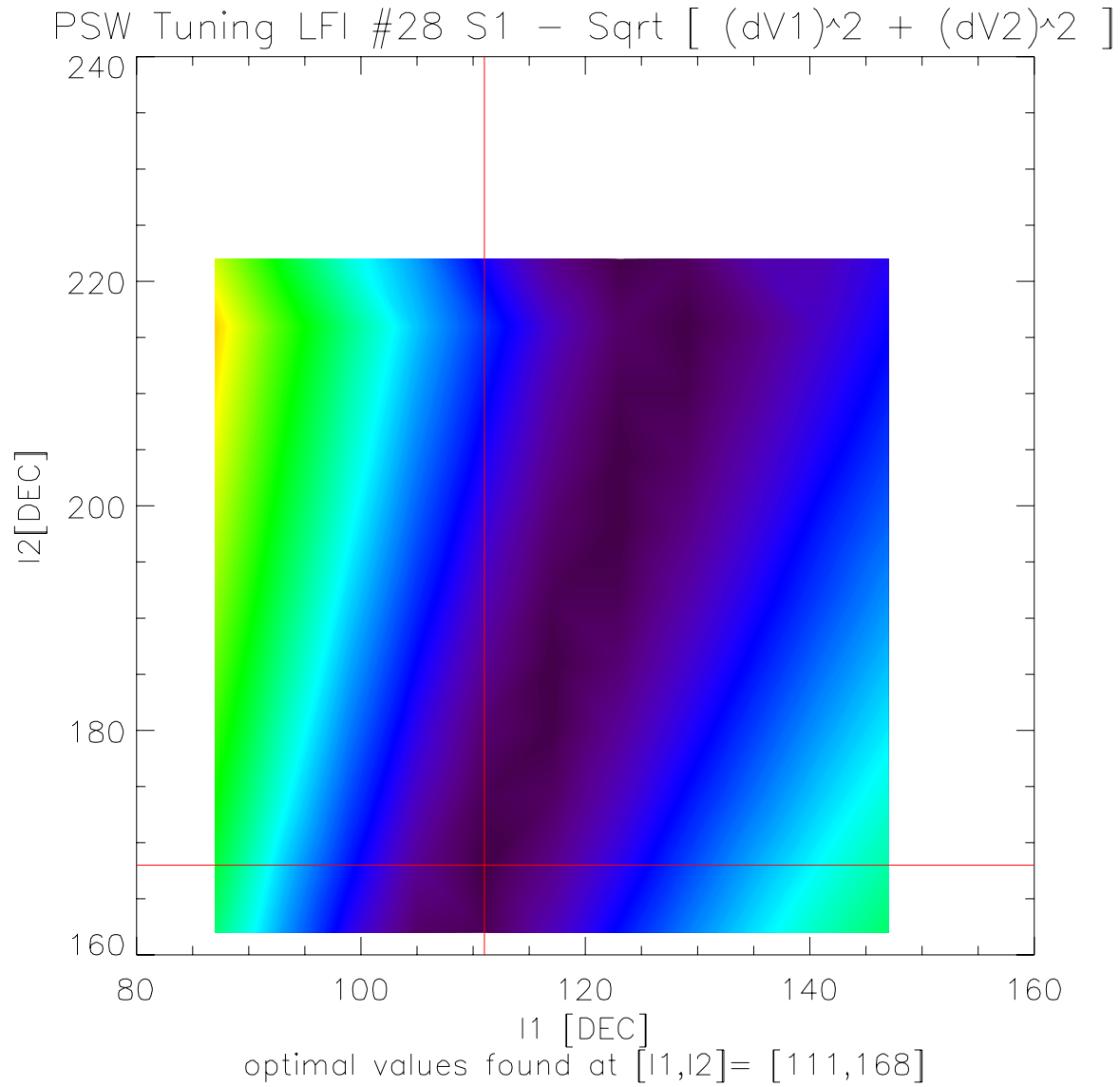

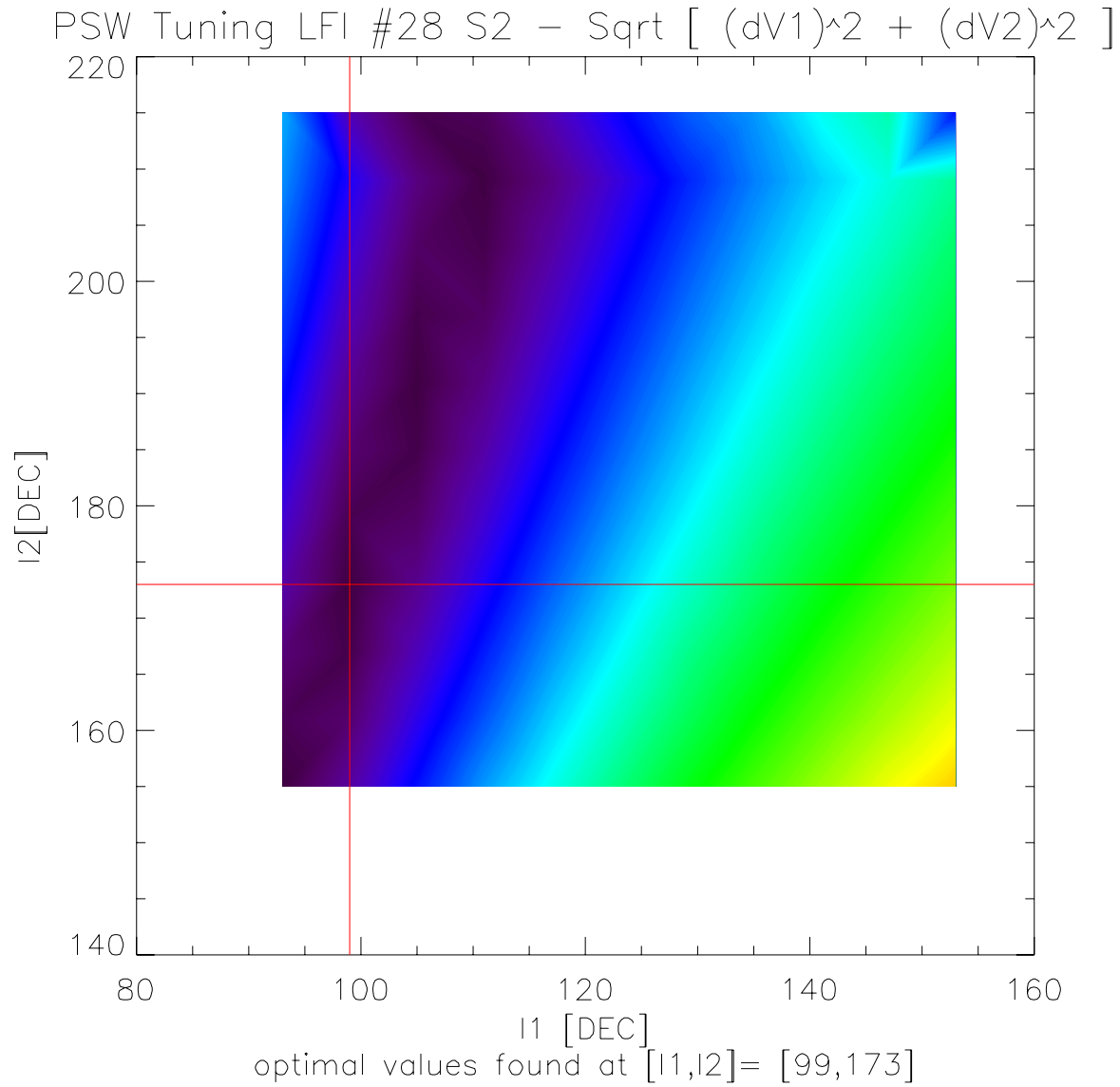



## 6.2 SECOND RUN

A second run of analysis has been appointed. In particular time windows have been defined more accurately and checked in `LAMA_View` to correct the last point values. Here the values found for optimal biases and the relative plots.

Table 2: Best Bias values as obtained from second run of analysis. RED values are those that are different from the values obtained from first run of analysis (also reported in between parenthesis)

	M1		M2		S1		S2	
	I1	I2	I1	I2	I1	I2	I1	I2
#24	128	250	77(91)	205(255)	84	235	86	215
#25	174	235	89	250	89(93)	250(255)	119	225
#26	98	245	153	210	135	230	93	230
#27	178	180	144	214	117(138)	154(192)	128	200
#28	150(132)	204(162)	105(117)	164(188)	111	168	93(99)	155(173)



### 6.2.1 RCA24 Contour Plots

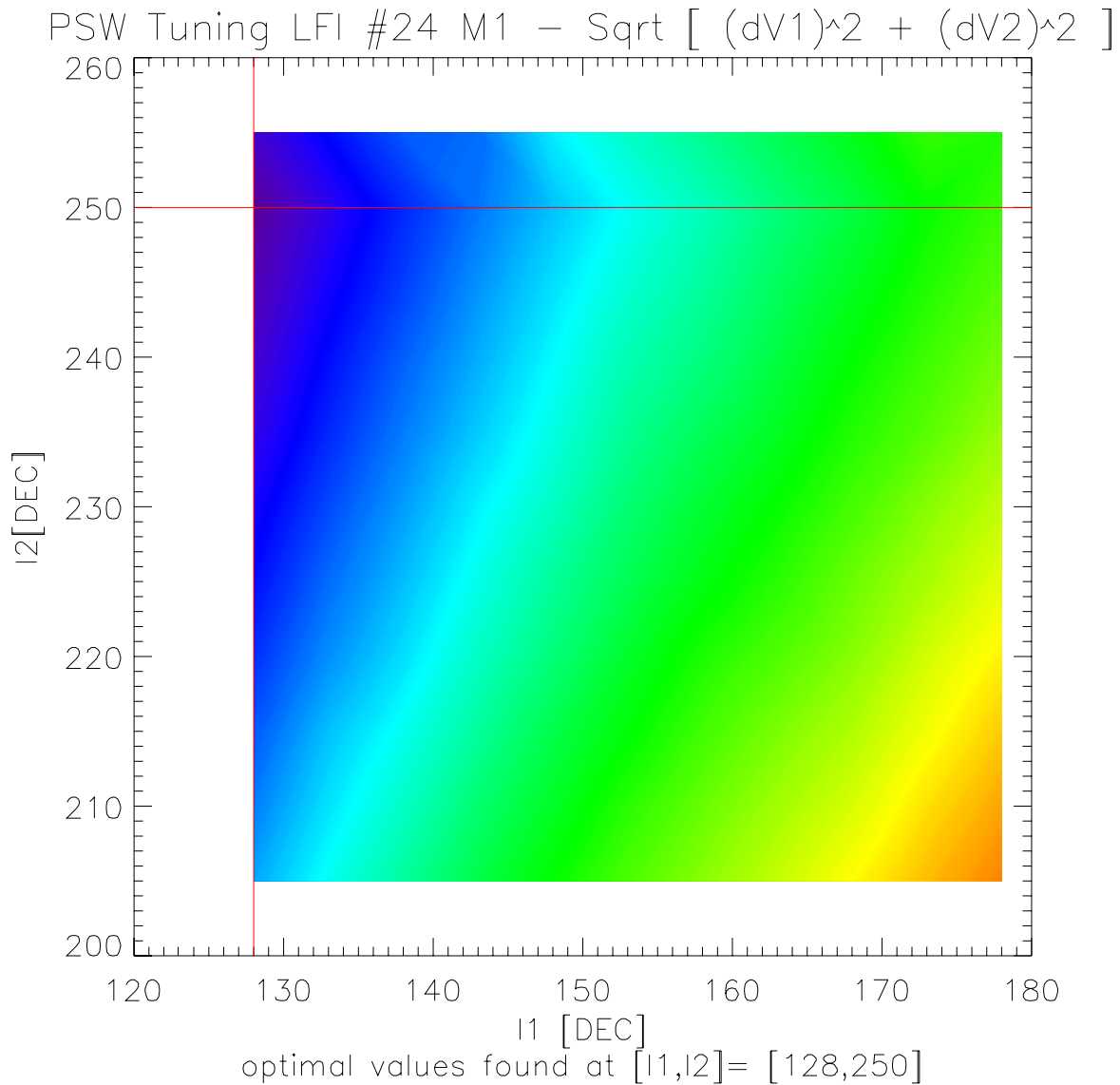

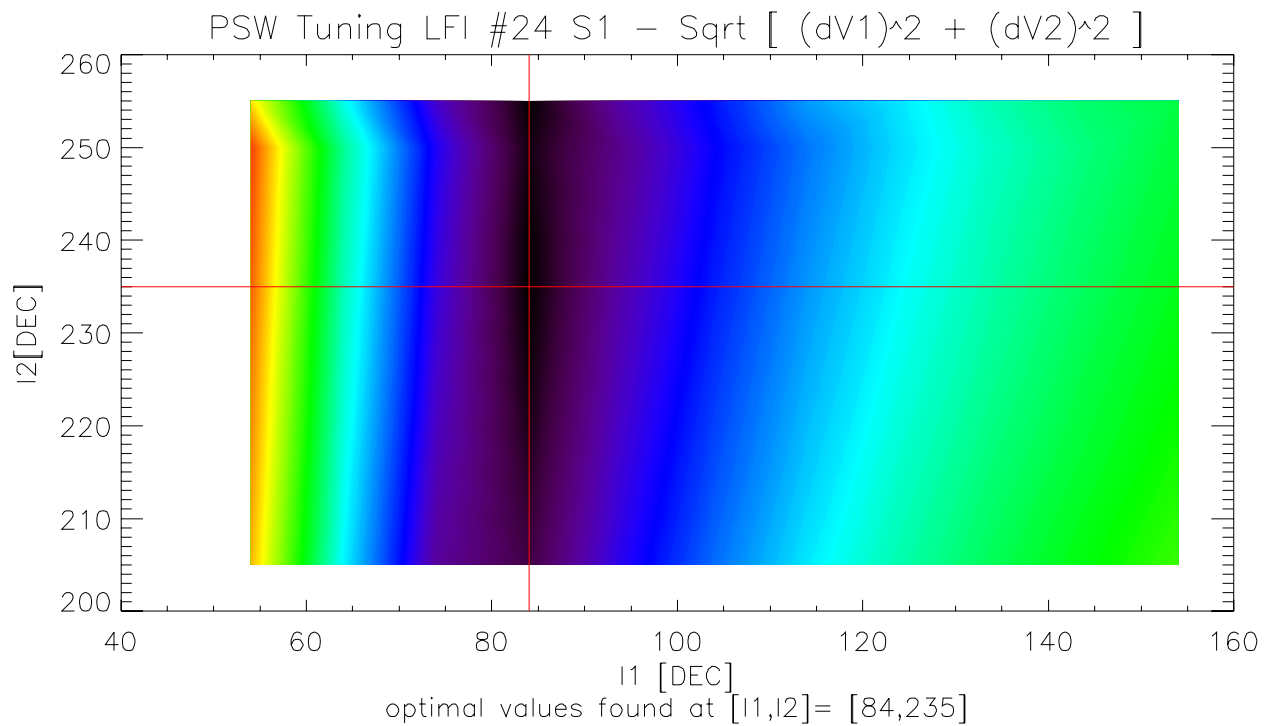
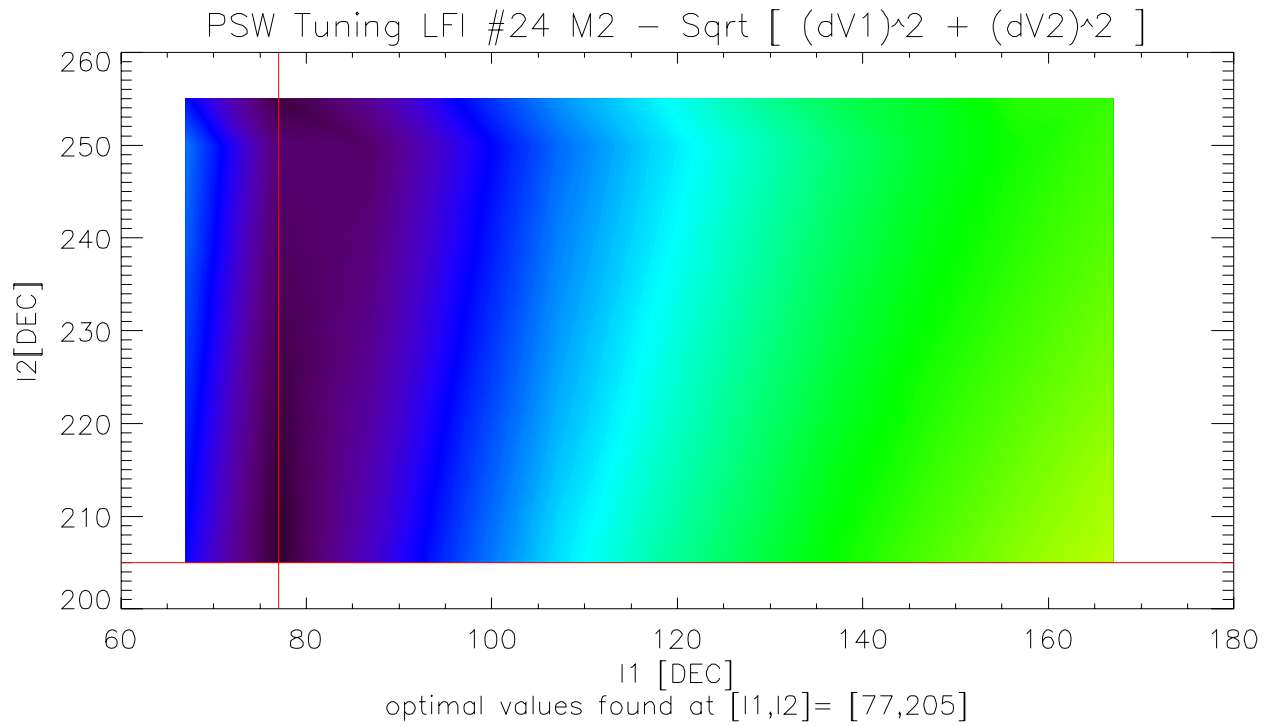

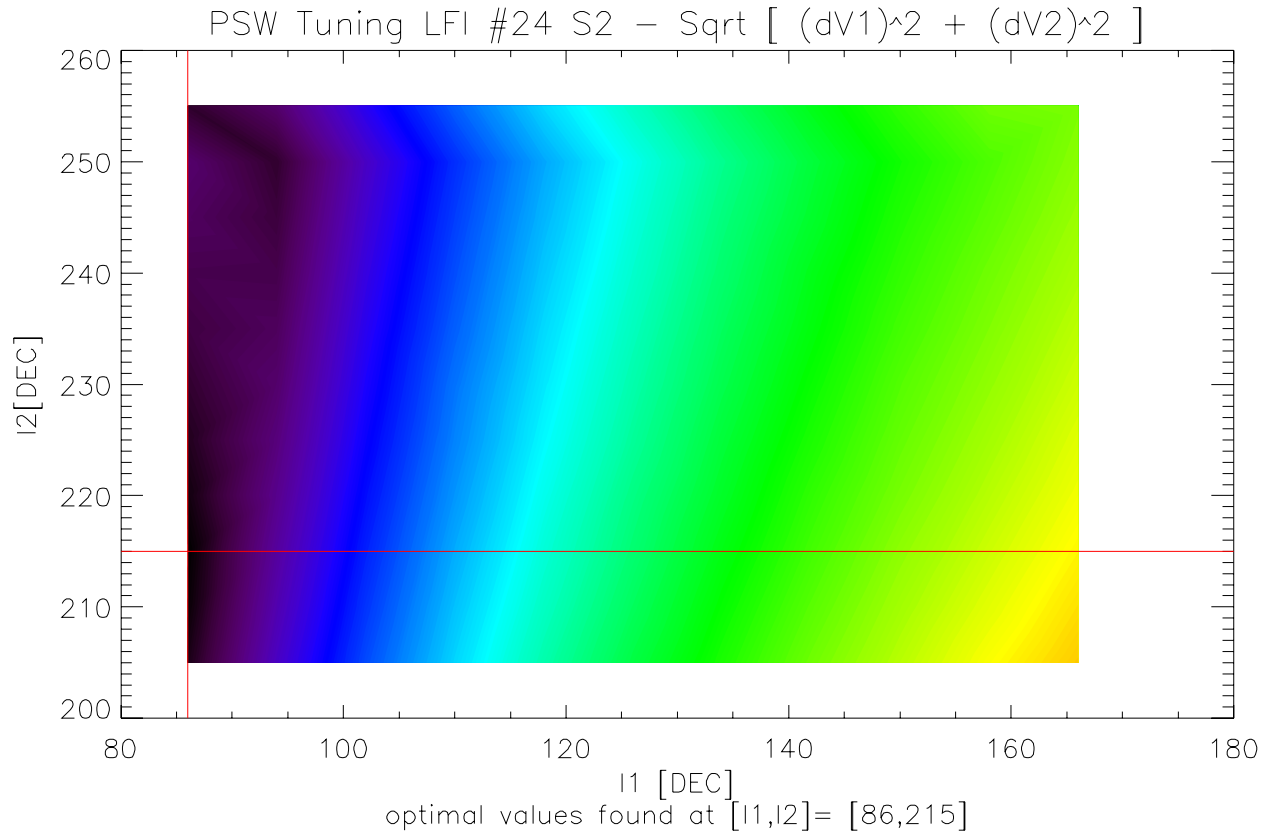



### 6.2.2 RCA25 Contour Plots

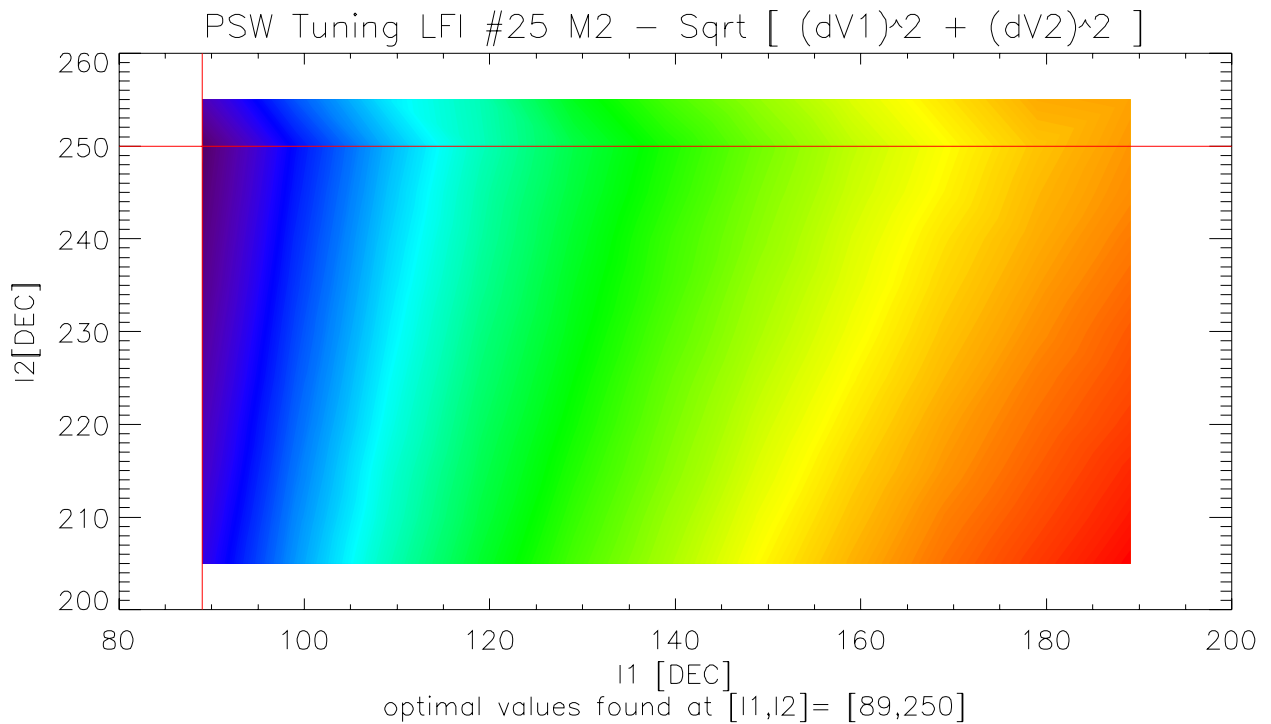
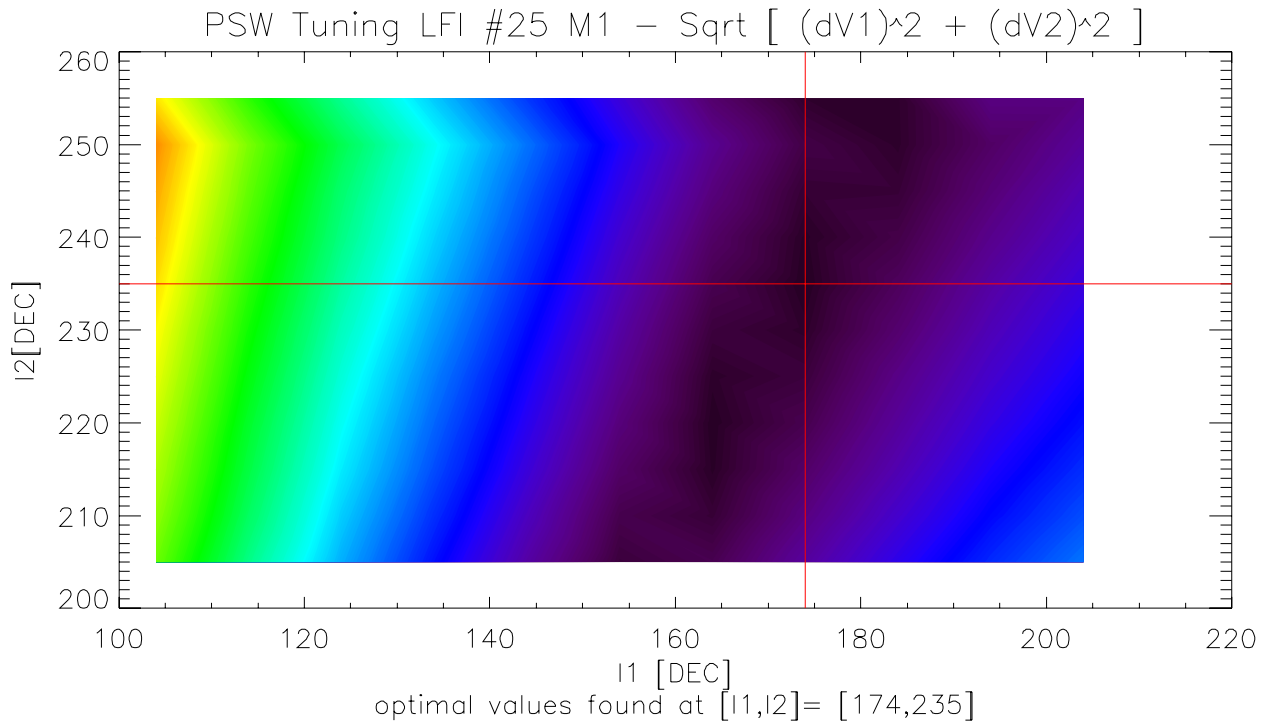

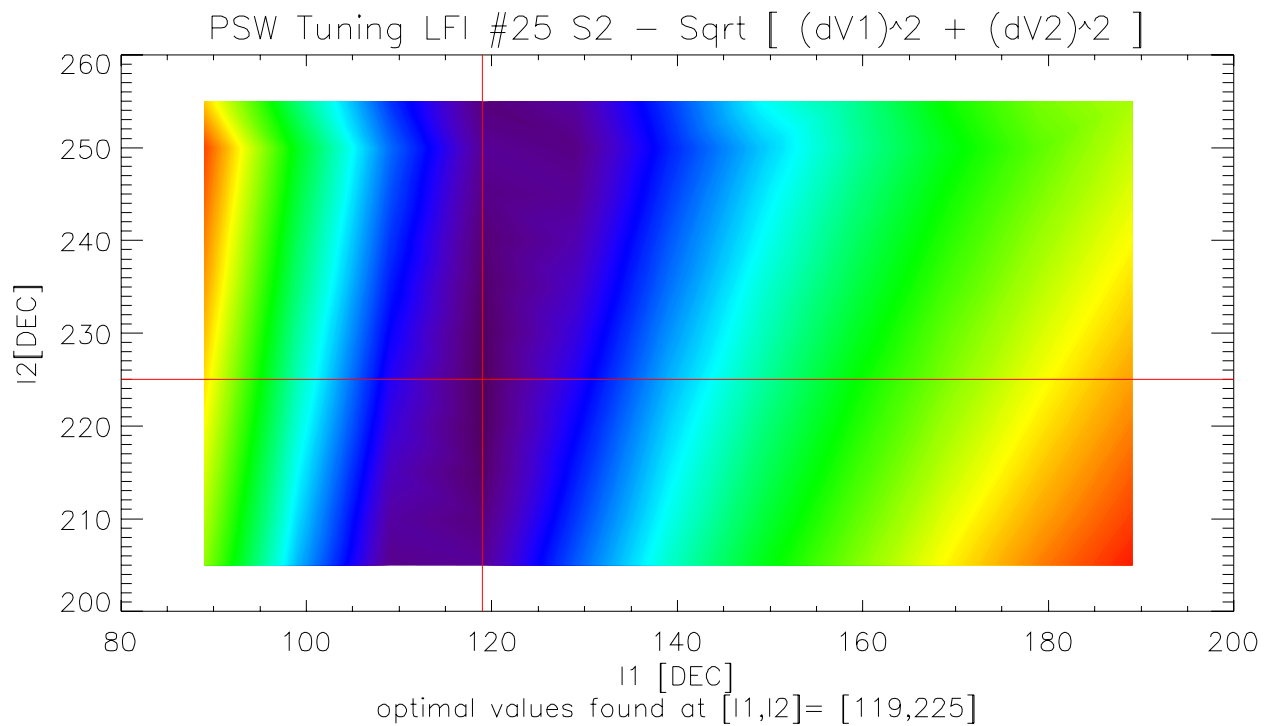
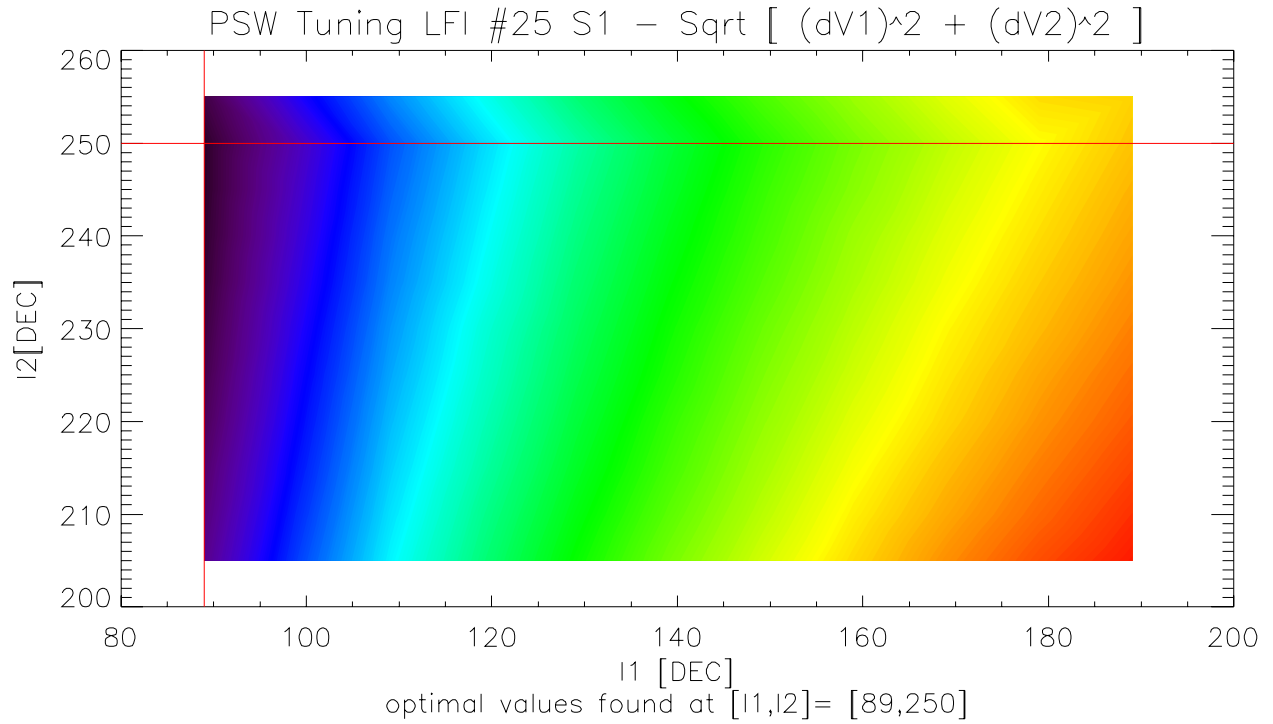



### 6.2.3 RCA26 Contour Plots

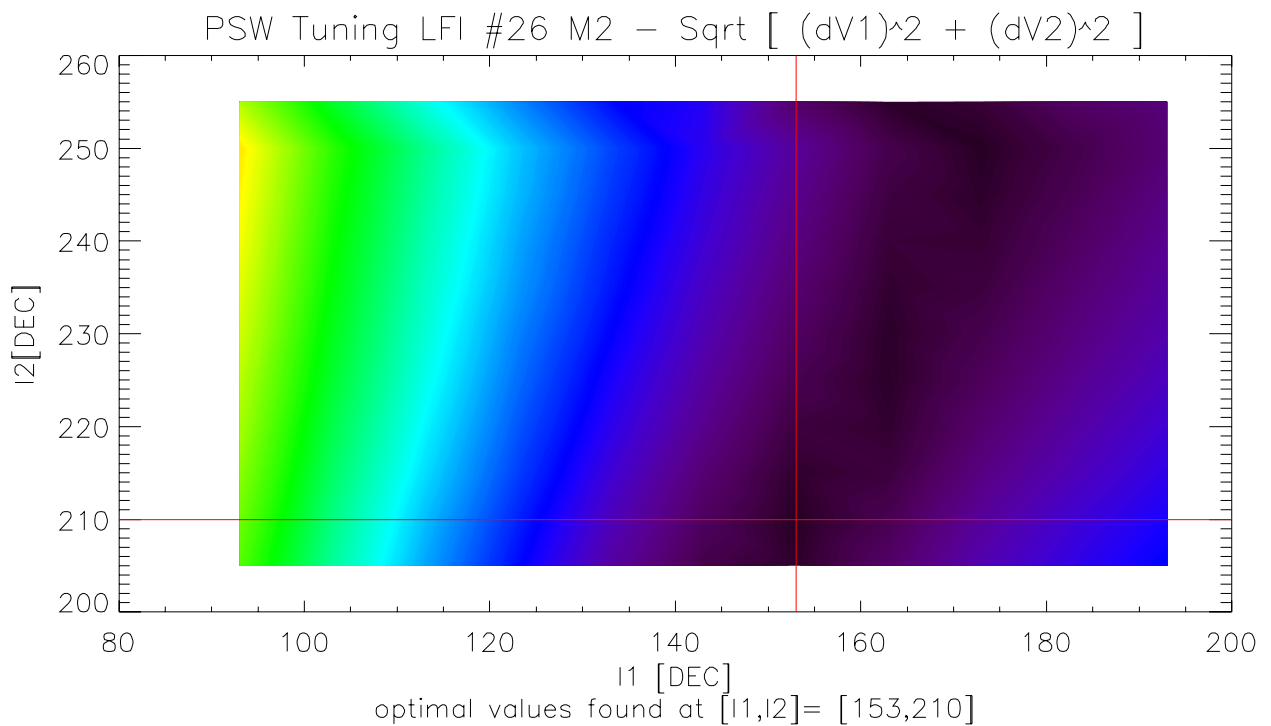
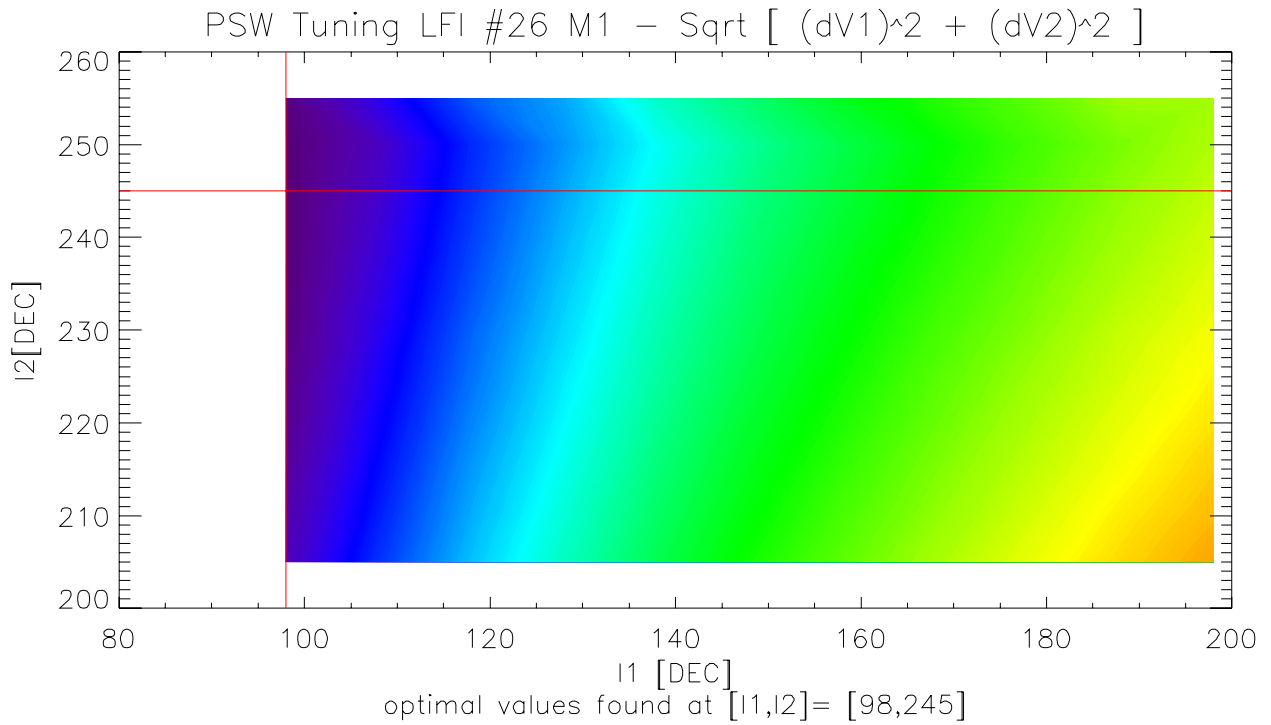

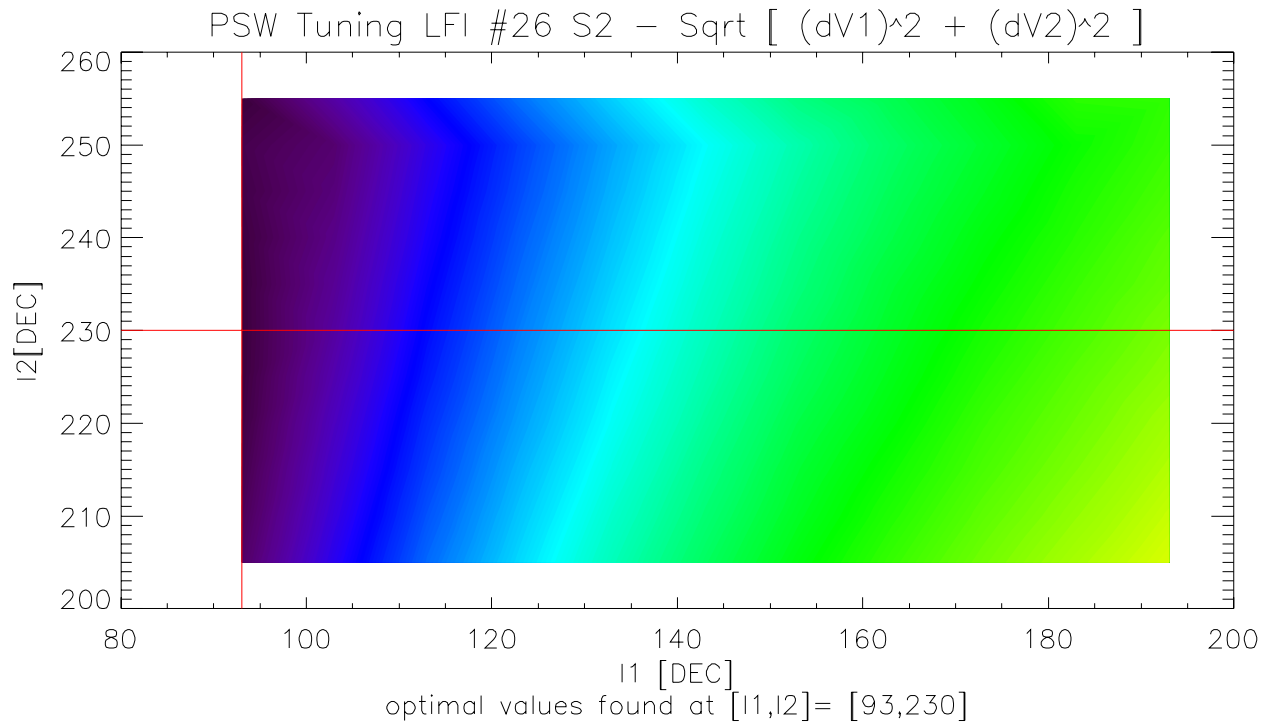
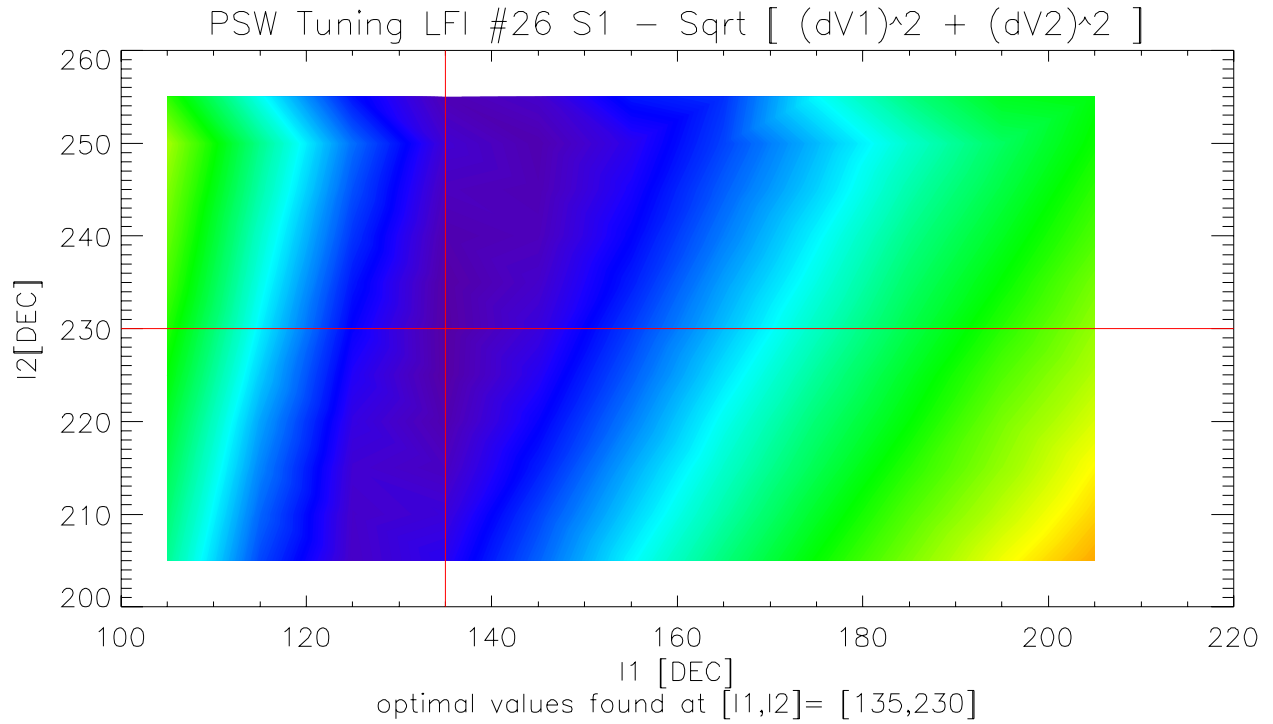



### 6.2.4 RCA27 Contour Plots

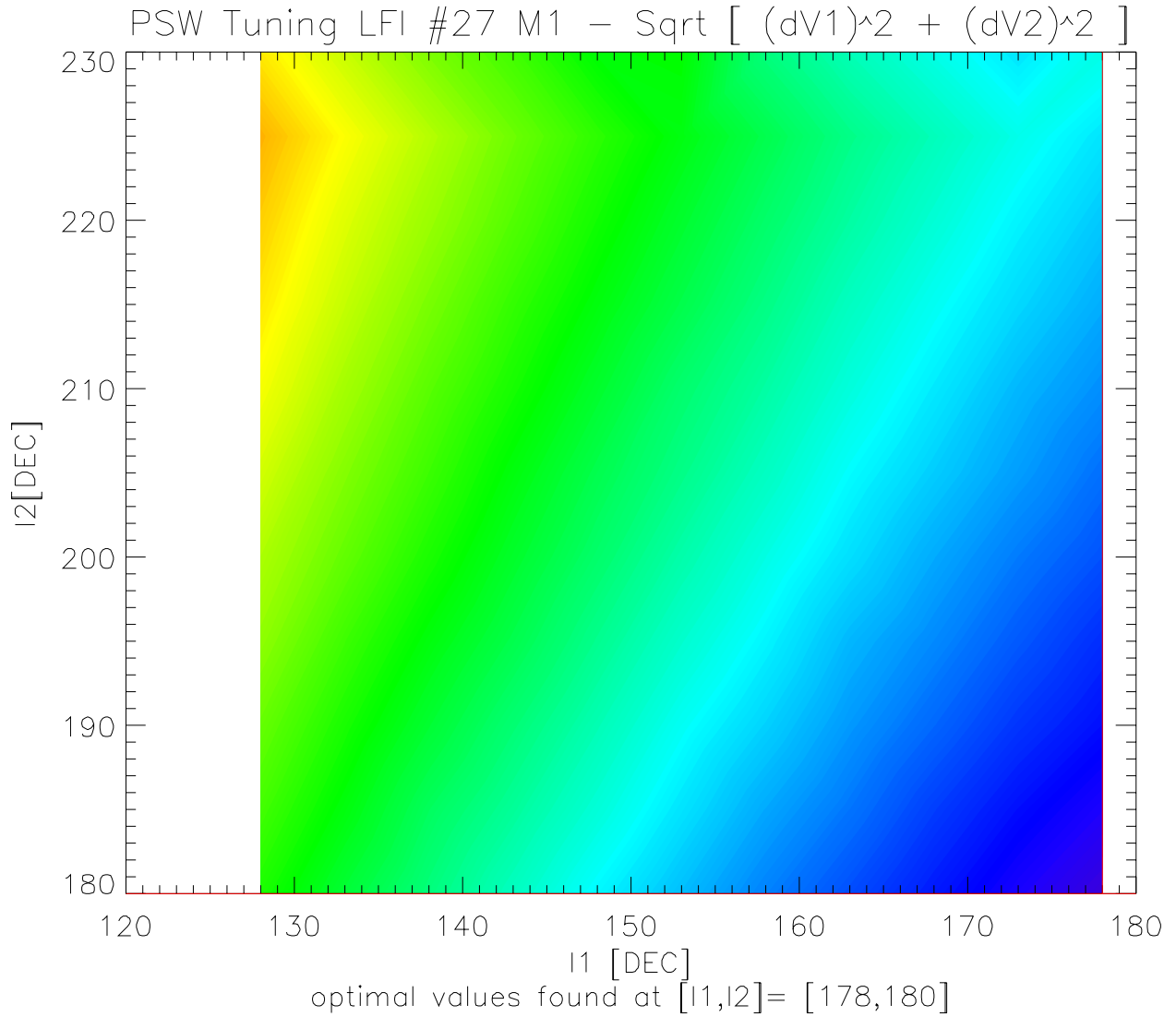

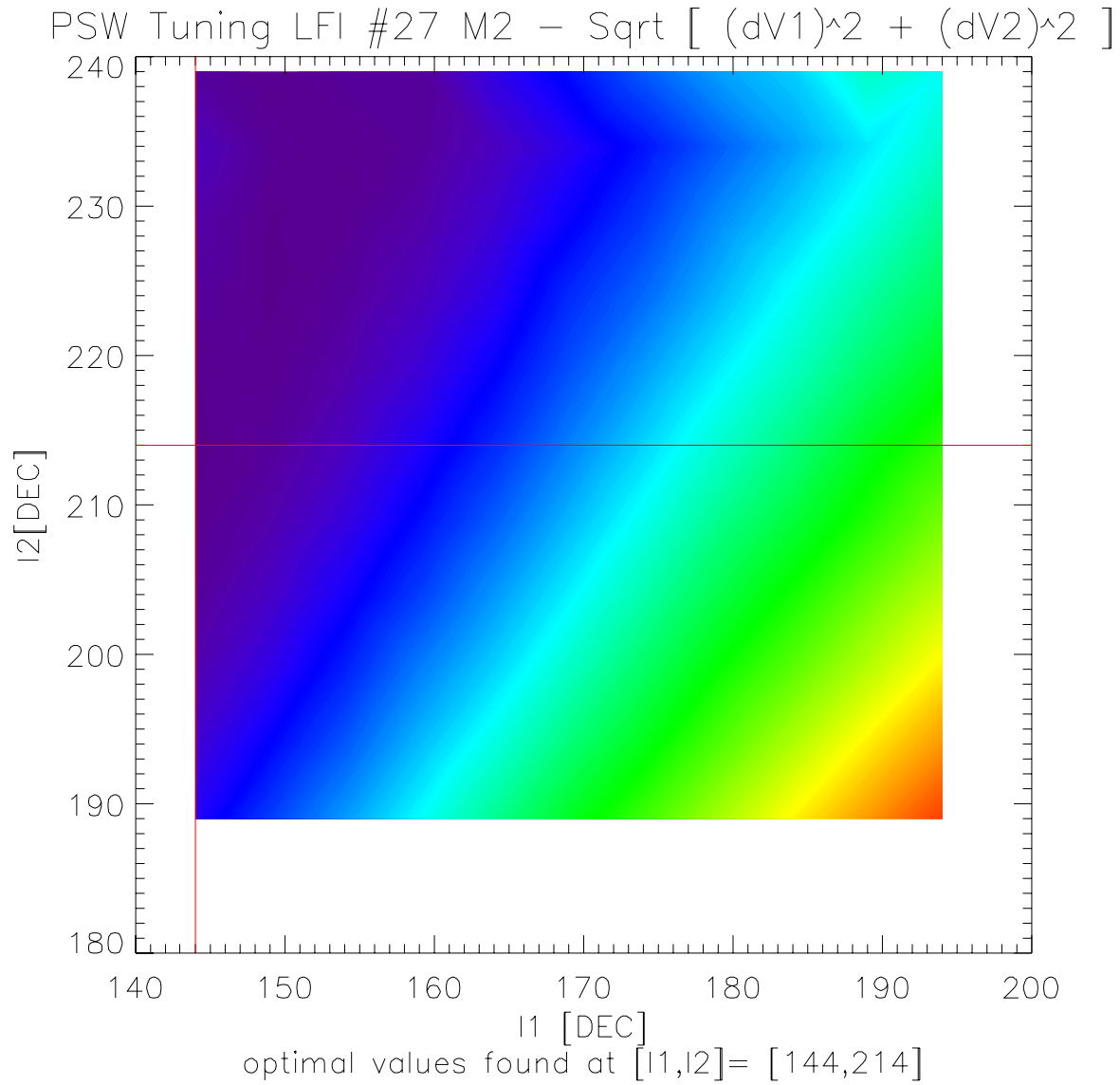

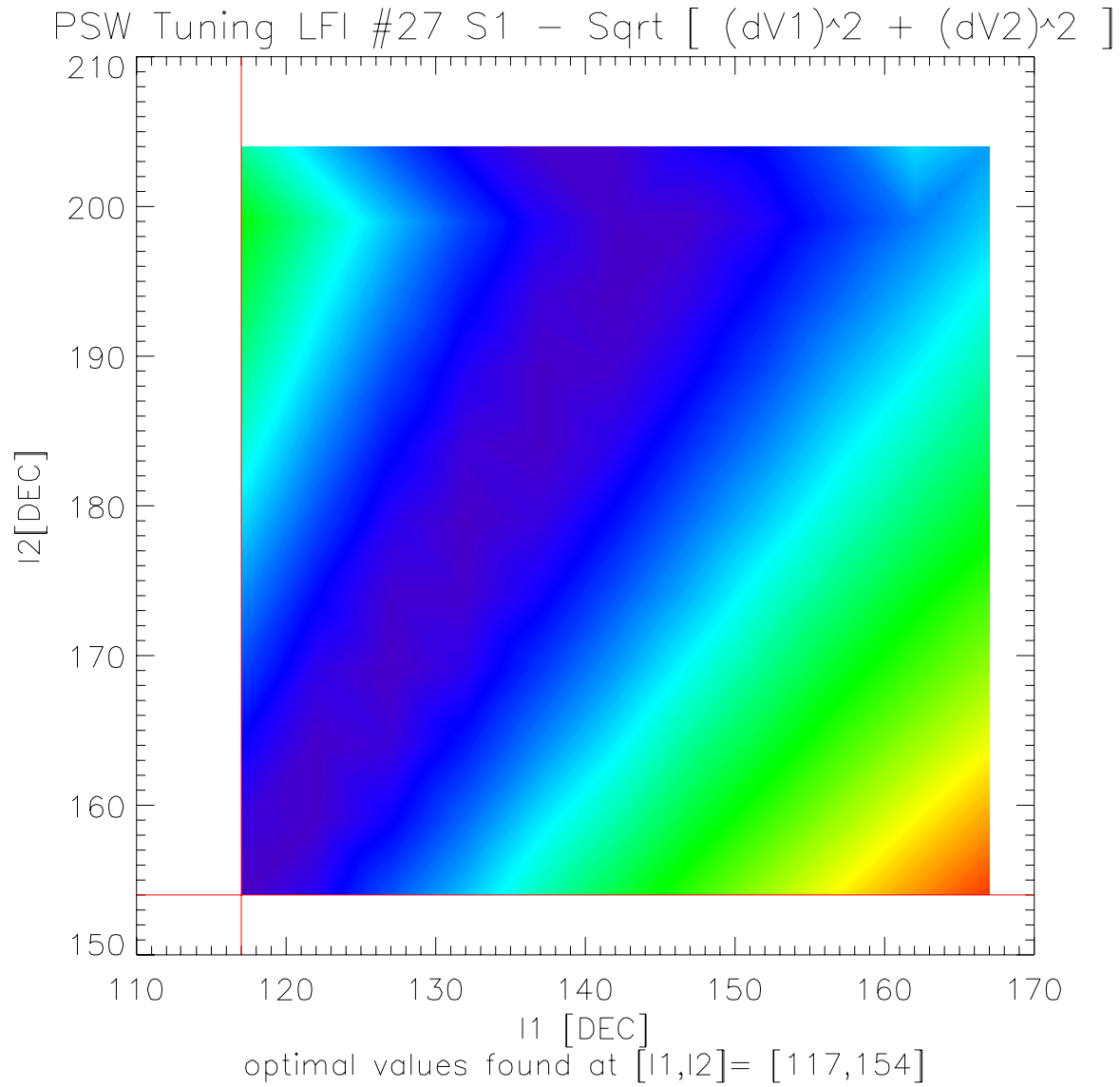

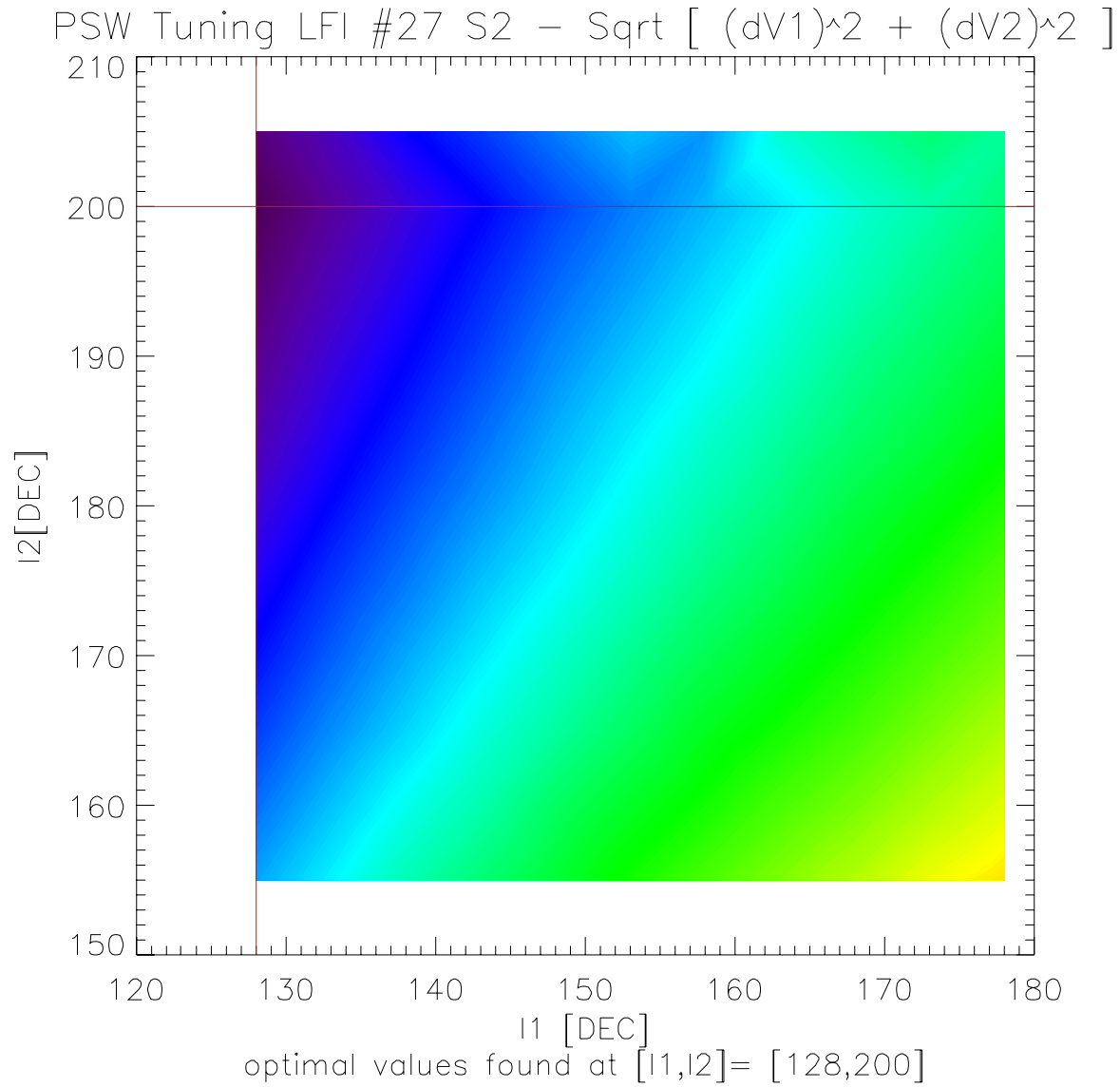



### 6.2.5 RCA28 Contour Plots

PSW Tuning LFI #28 M1 -  $\text{Sqrt} [ (dV1)^2 + (dV2)^2 ]$

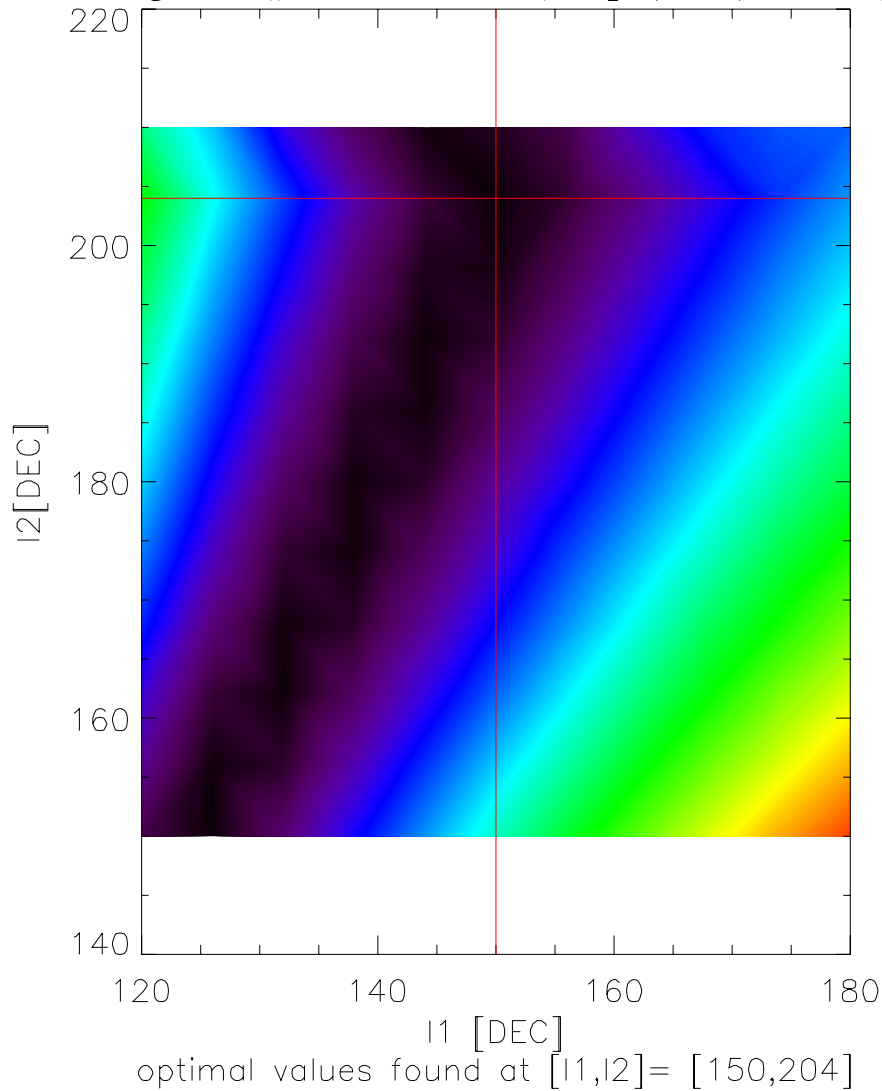

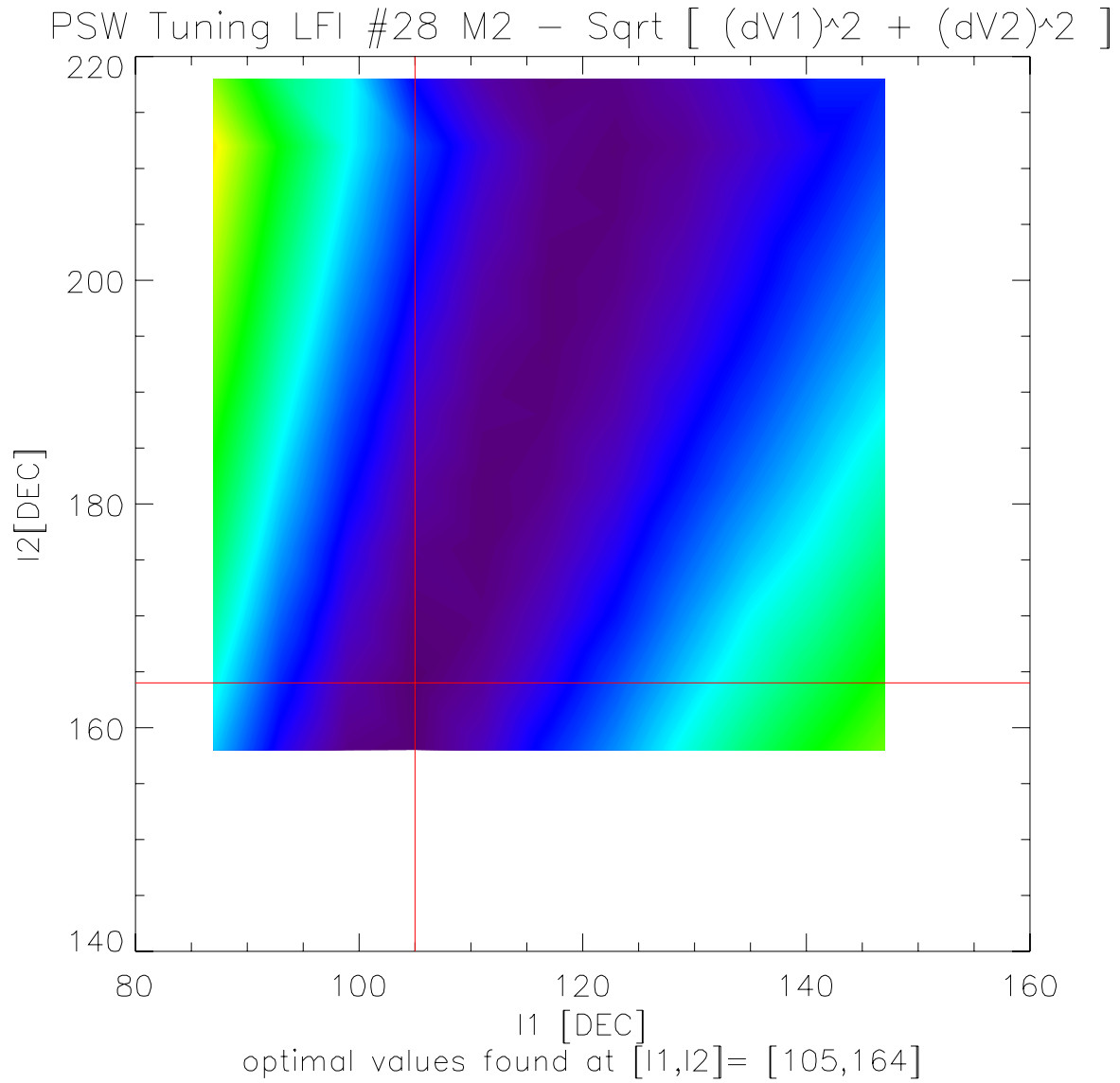

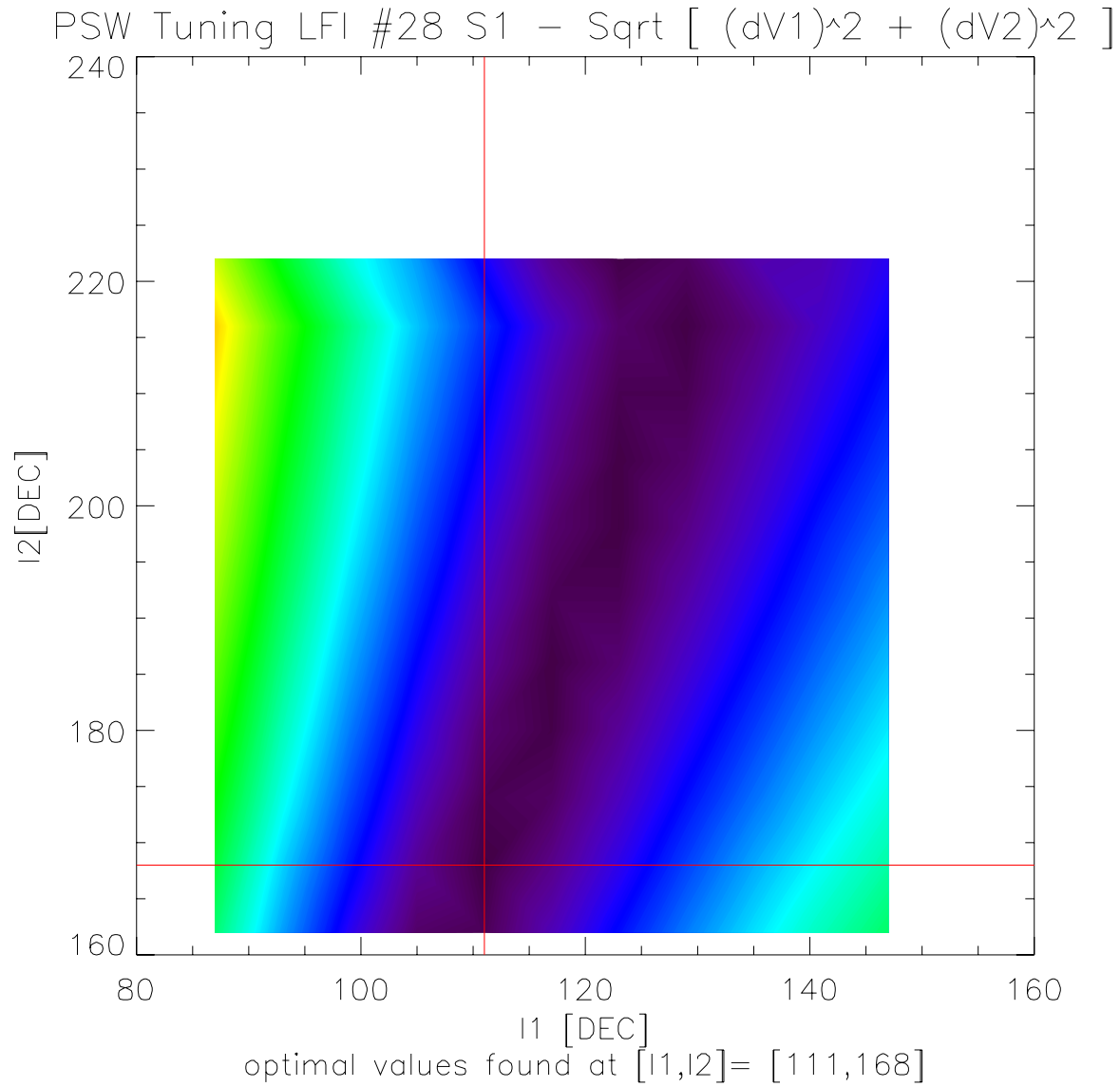

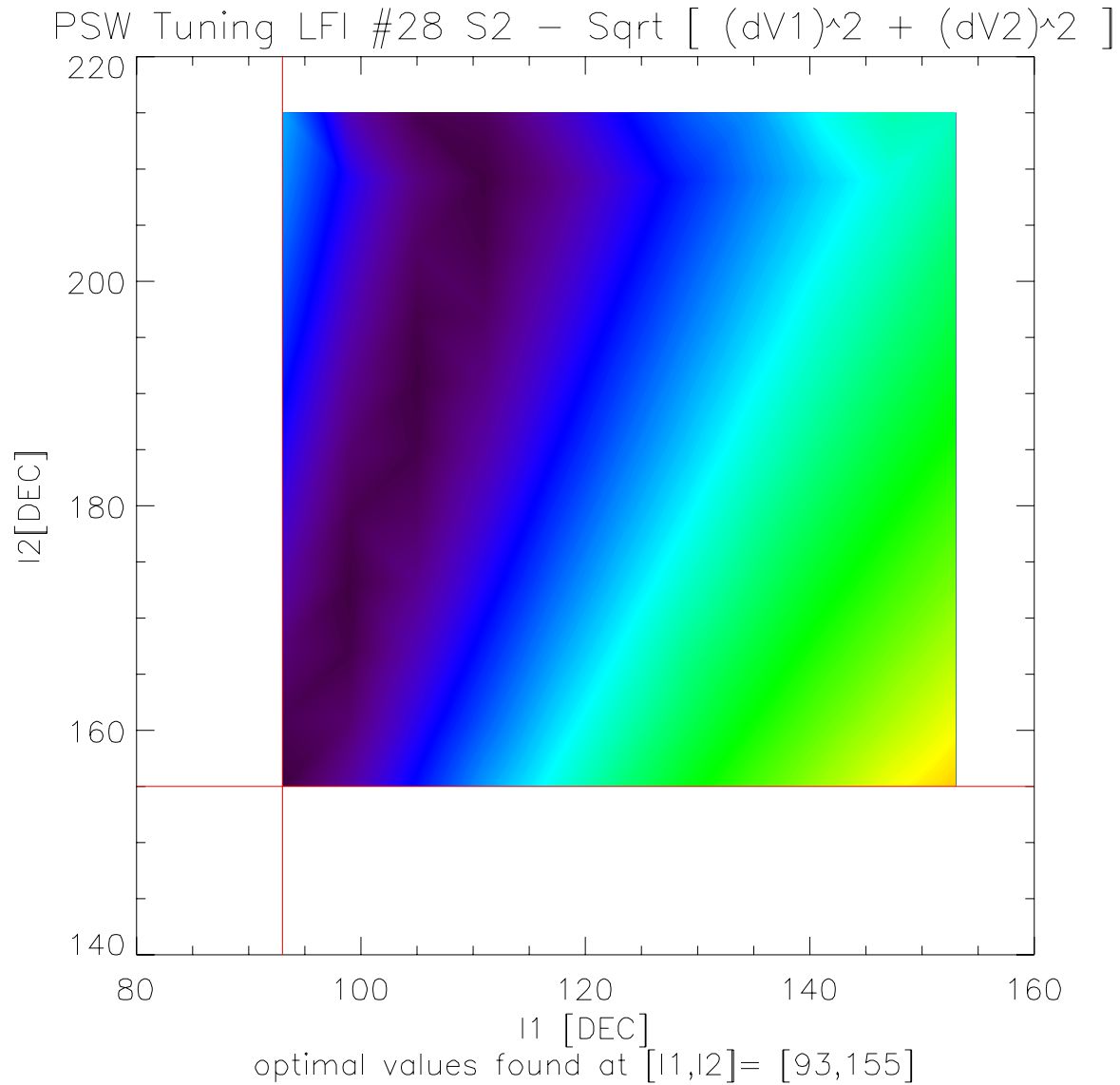



## 7 RCA, RAA, CSL AND OTHER QUESTIONS

The following plots show the comparison between the RCA, RAA and CSL phase switch tuning. The superimposed contour plot are in a different colour scale with respect previous plots being the lighter colours toward the best values of bias conditions.

- The squares are the RCA points and the red dot identifies the best current pair.
- The diamonds are the RAA points and red dot identifies the best current pair.
- Coloured map are the CSL data
- The red crossing lines identify the best current pair as derived from first run analysis.
- The black crossing lines identify the best current pair as derived from the second run analysis.



### 7.1 RCA24 Contour Plots

PSW Tuning LFI #24 M1 -  $\text{Sqrt} [ (dV1)^2 + (dV2)^2 ]$

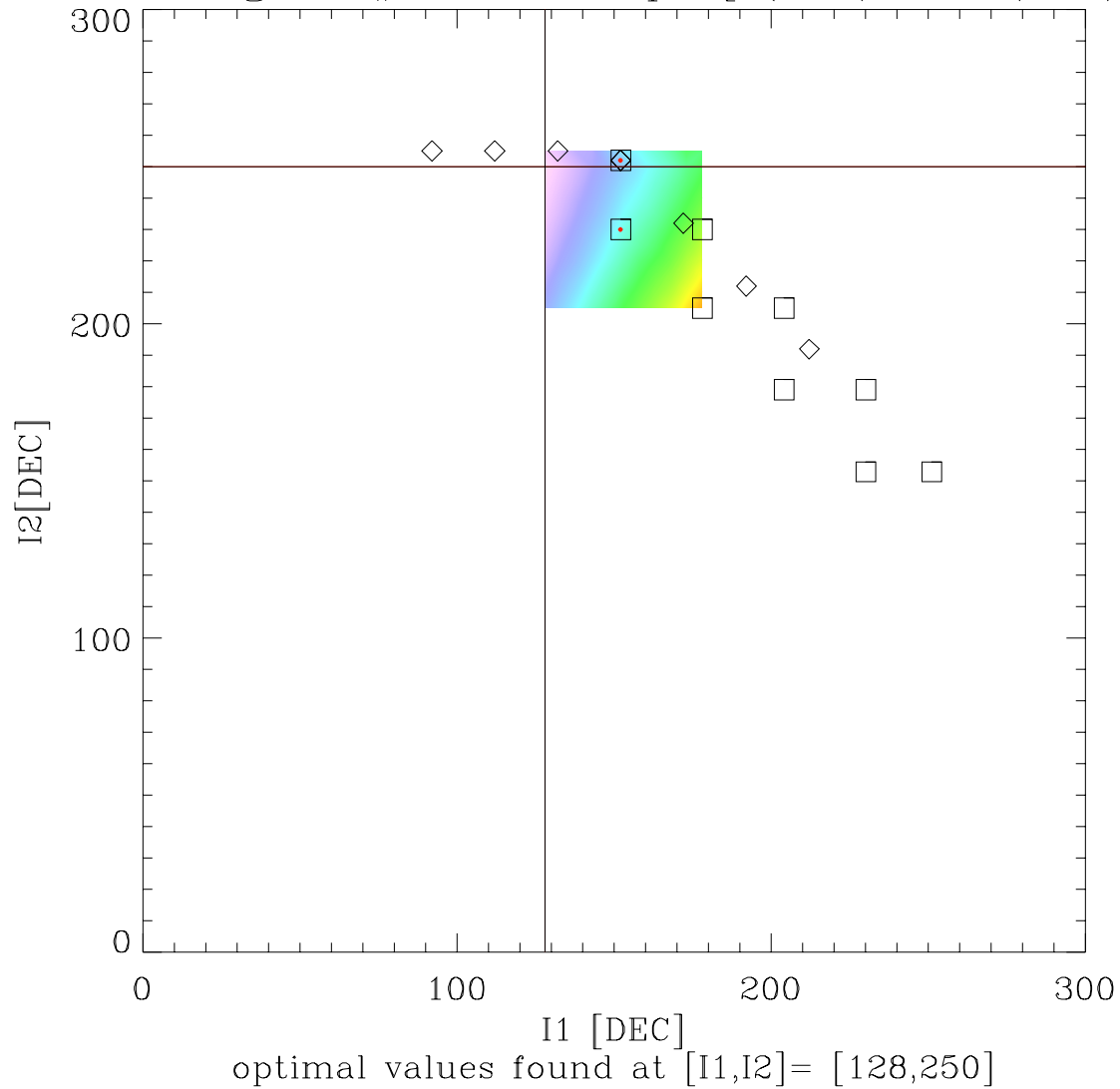



PSW Tuning LFI #24 M2 -  $\text{Sqrt} [ (dV1)^2 + (dV2)^2 ]$

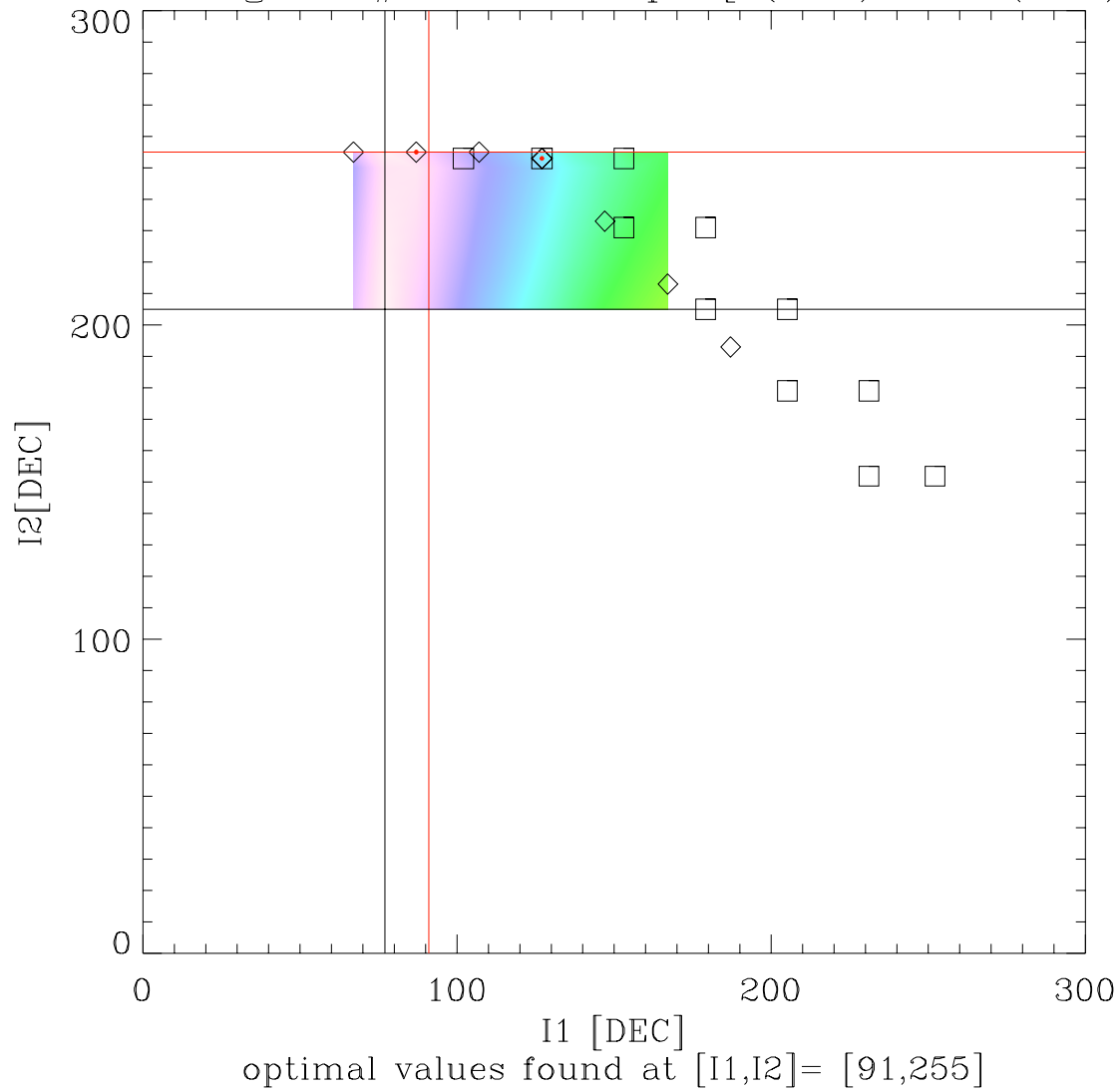



PSW Tuning LFI #24 S1 -  $\text{Sqrt} [ (dV1)^2 + (dV2)^2 ]$

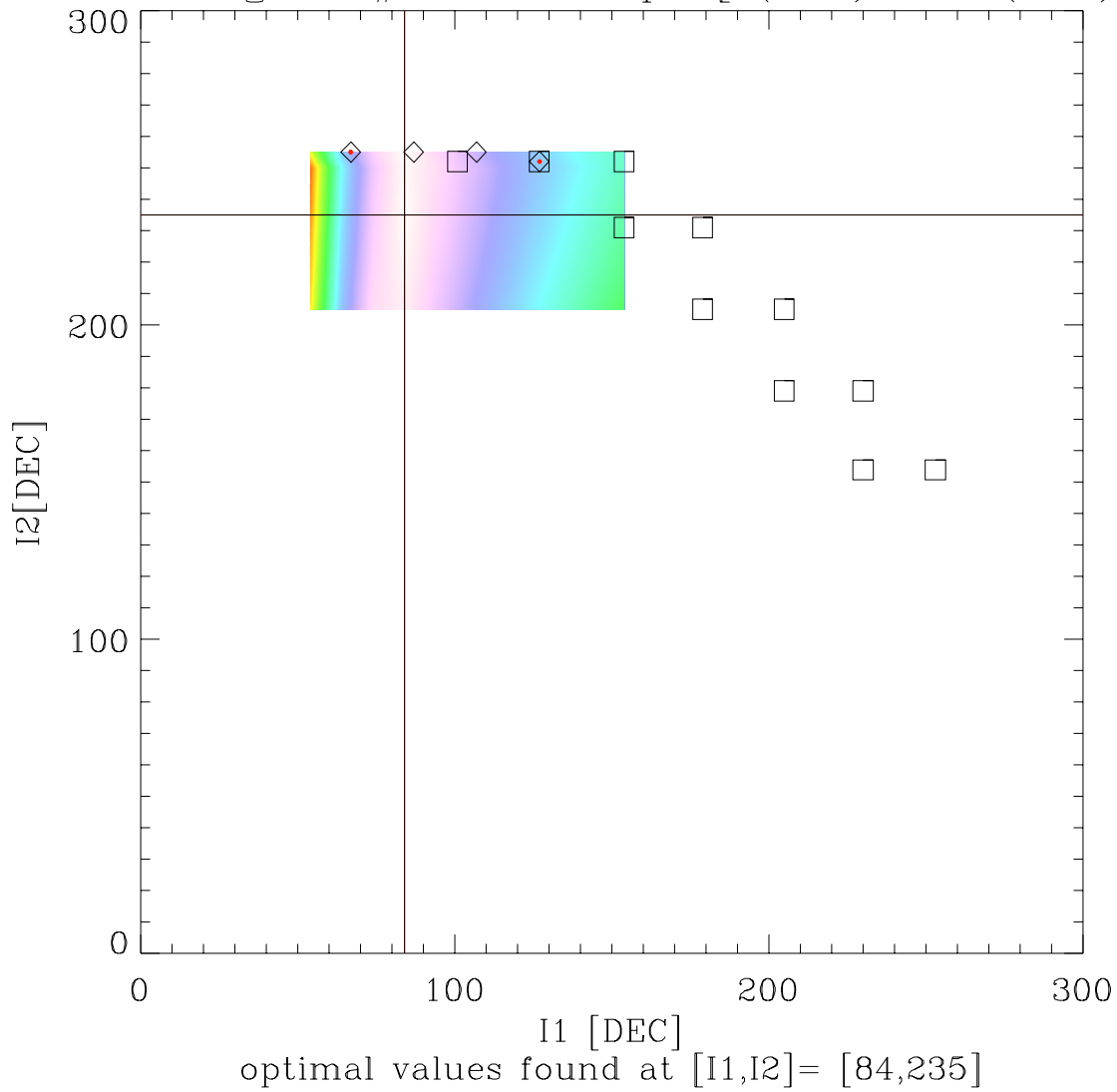



PSW Tuning LFI #24 S2 -  $\text{Sqrt} [ (dV1)^2 + (dV2)^2 ]$

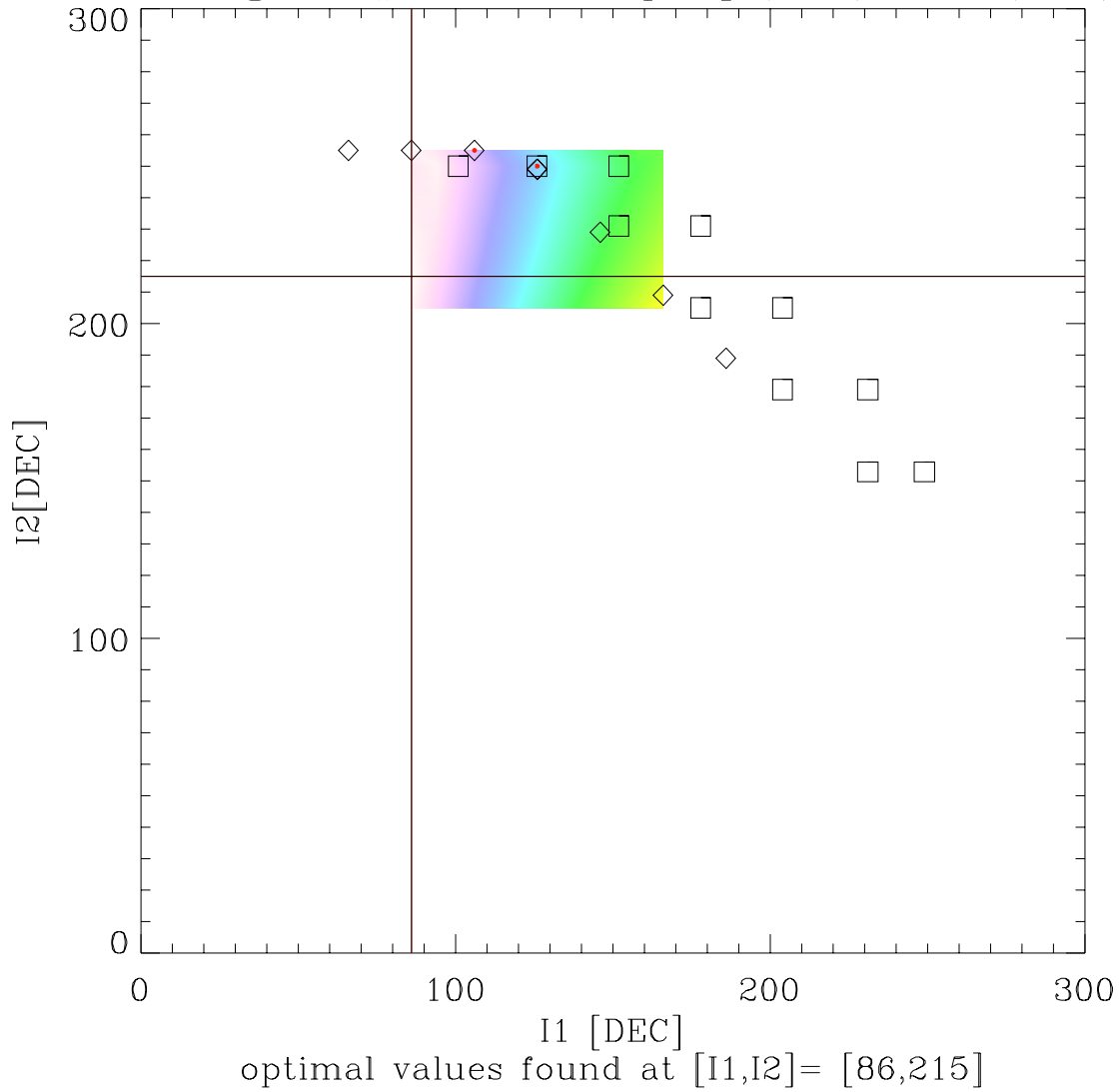



## 7.2 RCA25 Contour Plots

PSW Tuning LFI #25 M1 -  $\text{Sqrt} [ (dV1)^2 + (dV2)^2 ]$

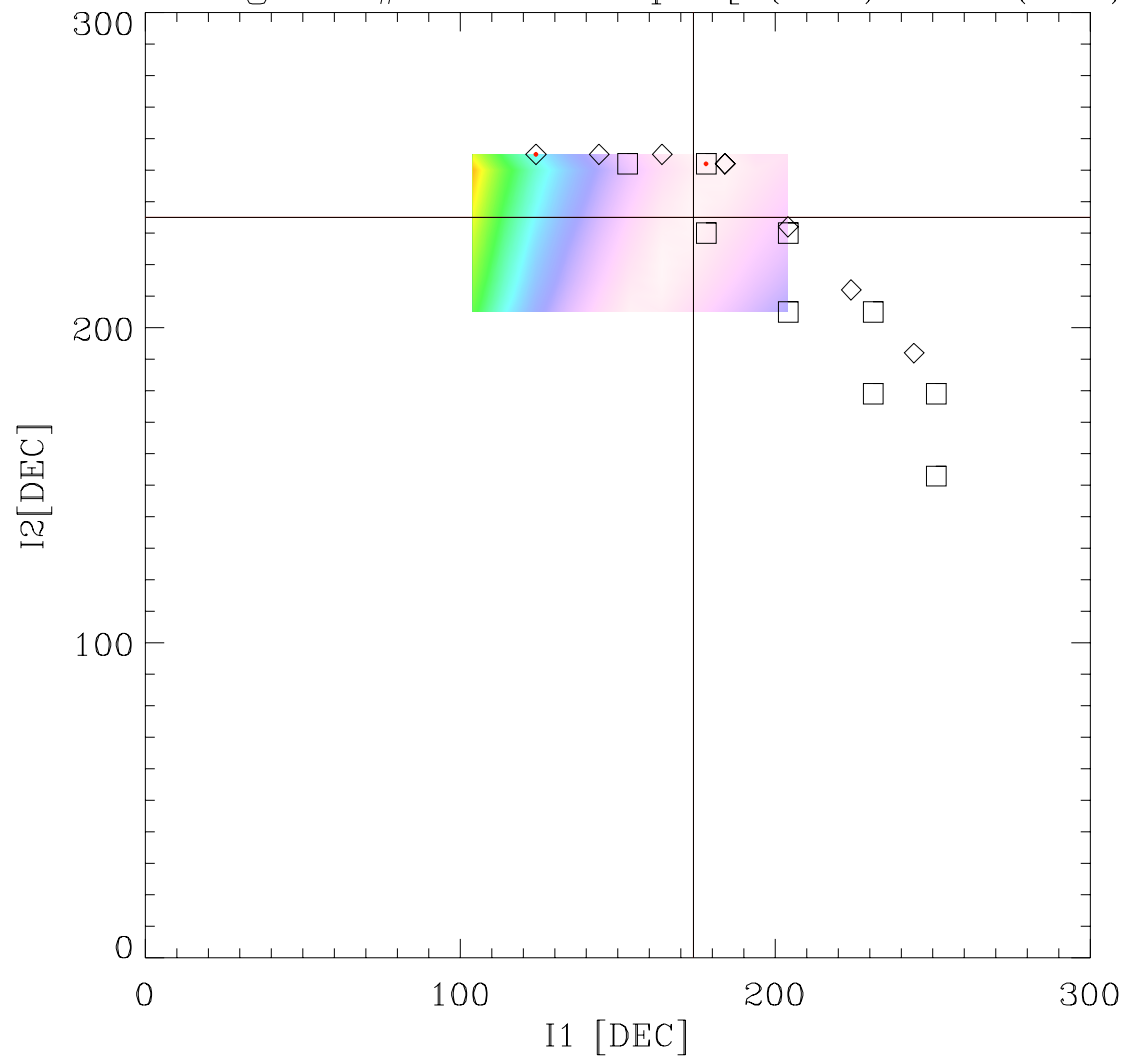

optimal values found at  $[I1, I2] = [174, 235]$



PSW Tuning LFI #25 M2 -  $\text{Sqrt} [ (dV1)^2 + (dV2)^2 ]$

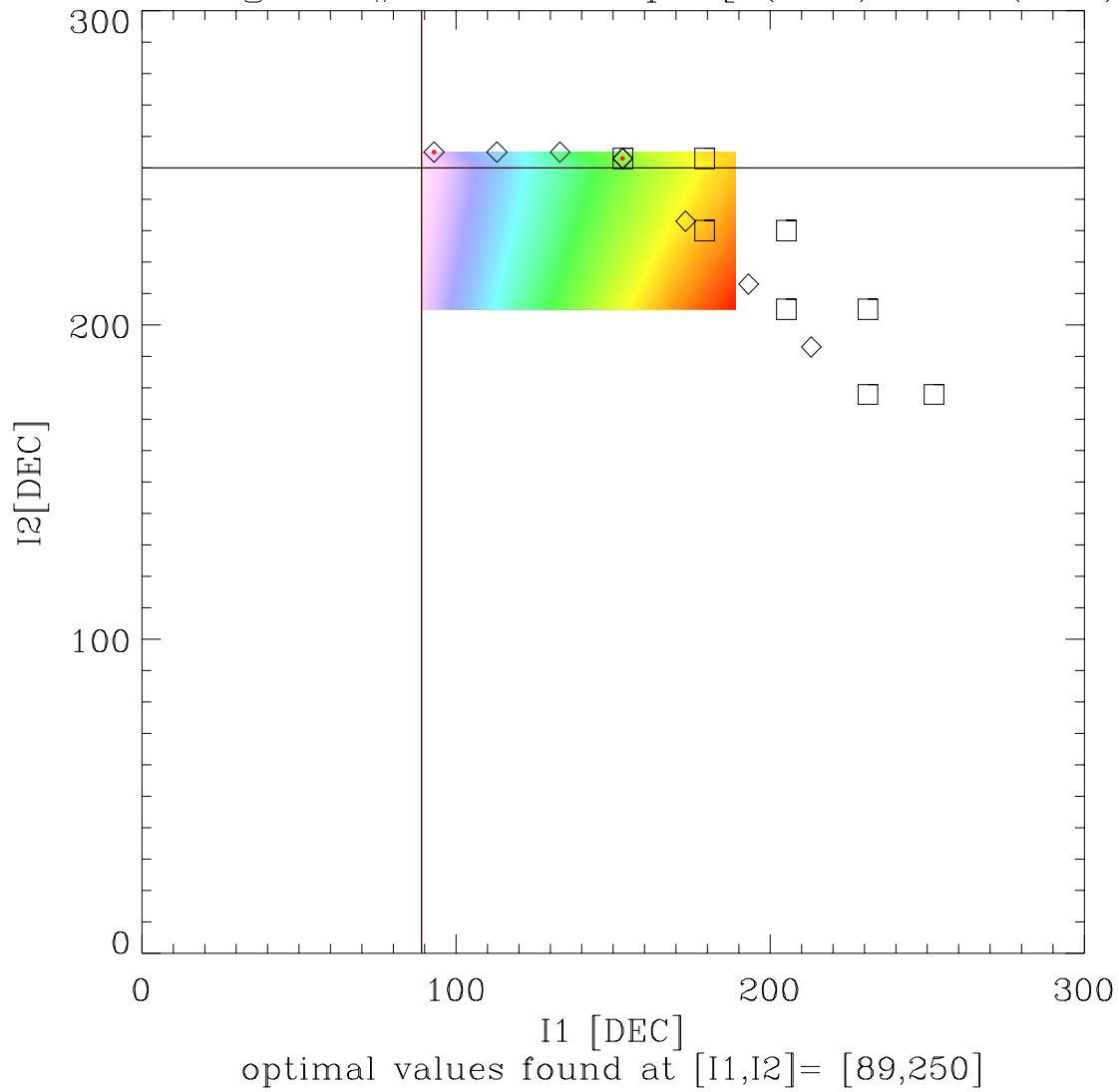



PSW Tuning LFI #25 S1 -  $\text{Sqrt} [ (dV1)^2 + (dV2)^2 ]$

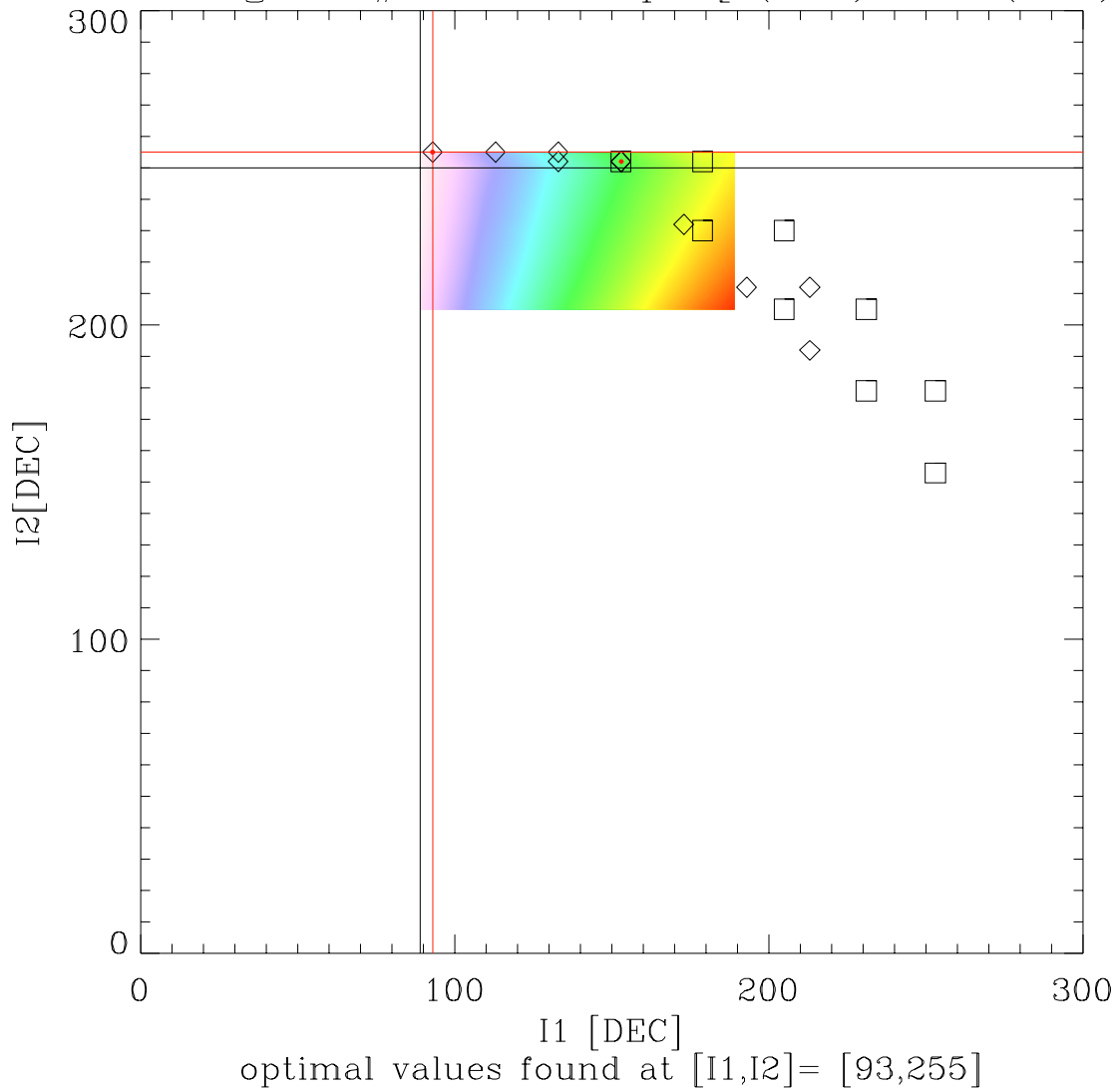



PSW Tuning LFI #25 S2 -  $\text{Sqrt} [ (dV1)^2 + (dV2)^2 ]$

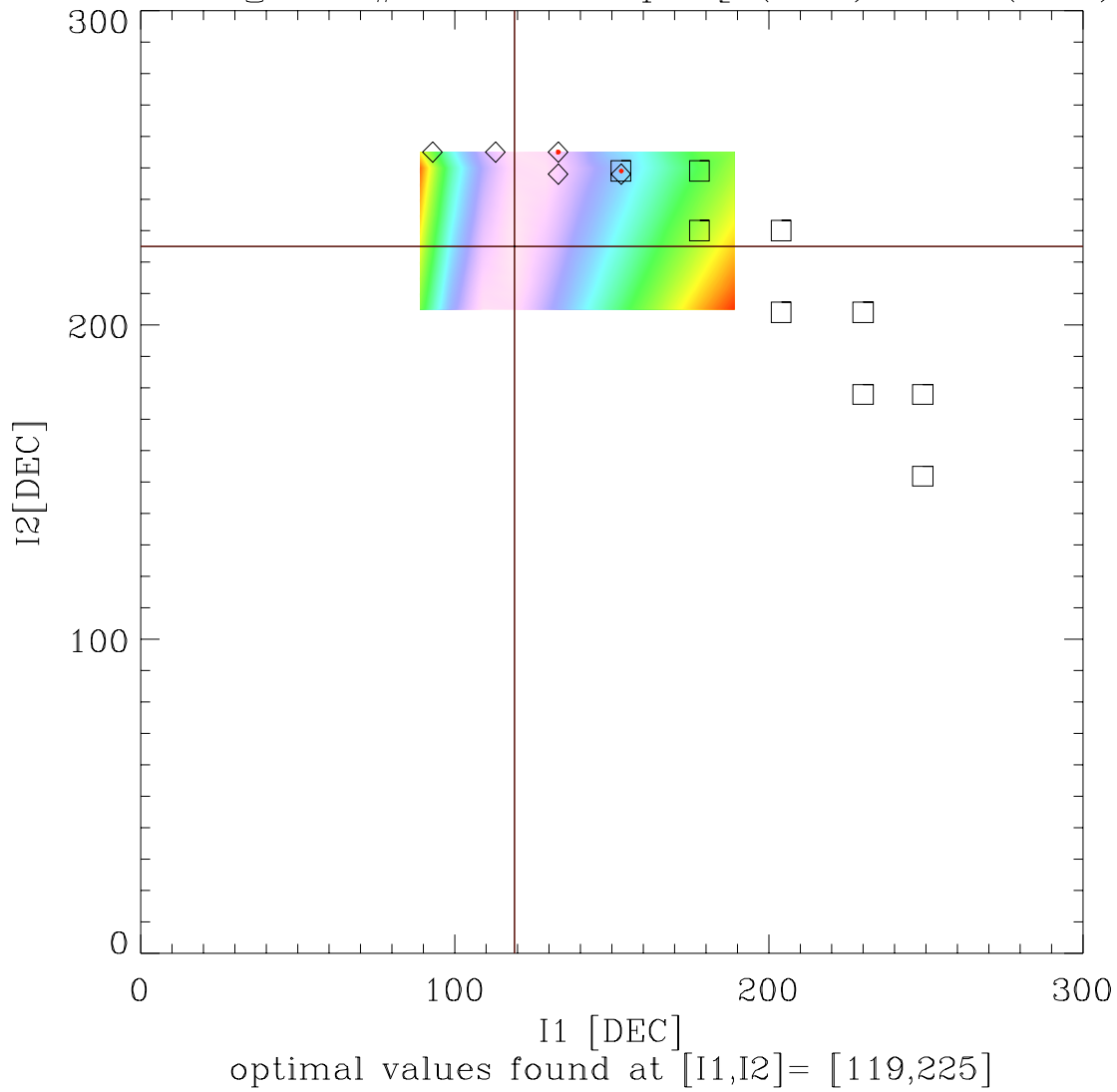



### 7.3 RCA26 Contour Plots

PSW Tuning LFI #26 M1 -  $\text{Sqrt} [ (dV1)^2 + (dV2)^2 ]$

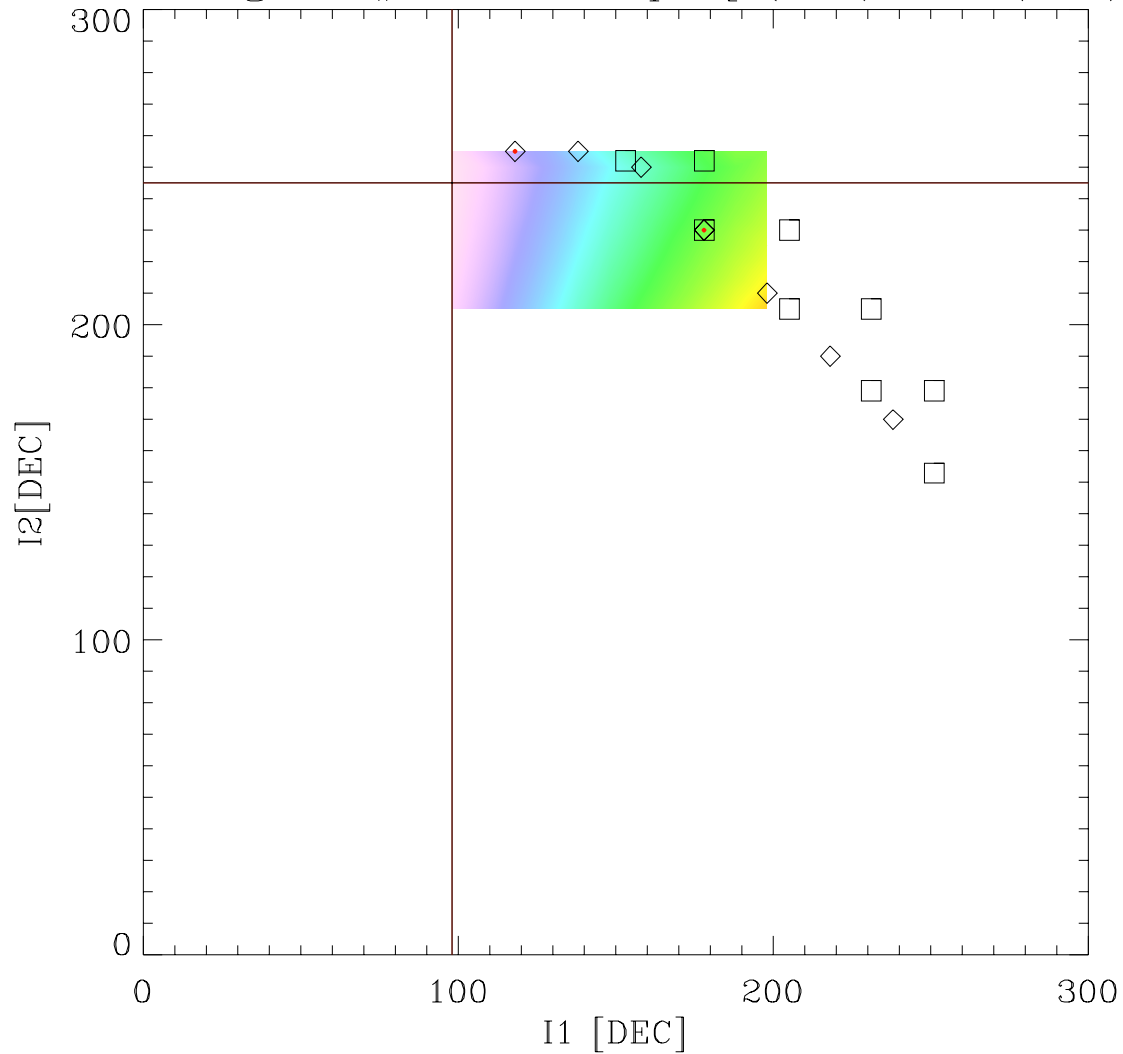

optimal values found at  $[I1, I2] = [98, 245]$



PSW Tuning LFI #26 M2 -  $\text{Sqrt} [ (dV1)^2 + (dV2)^2 ]$

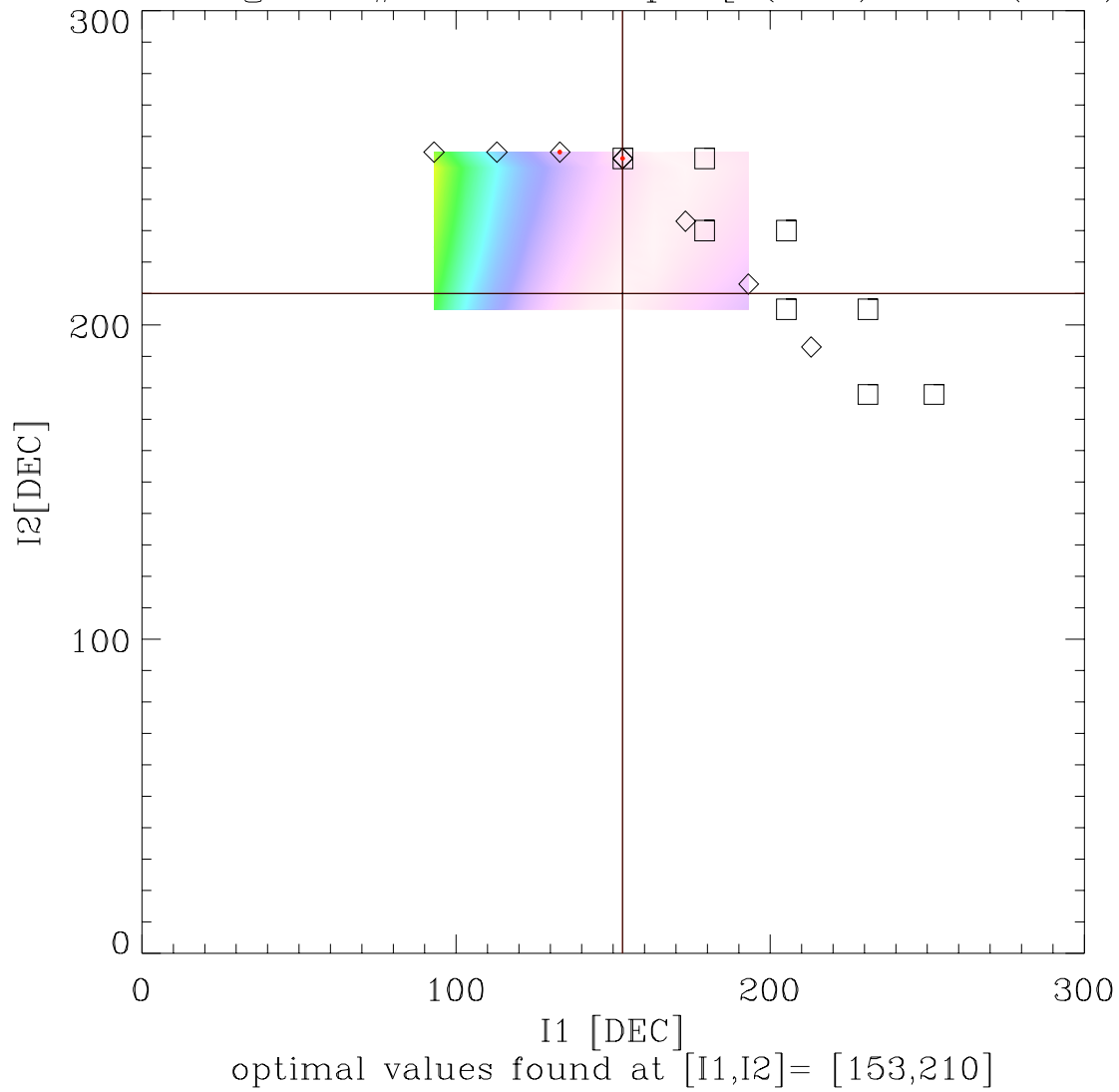



PSW Tuning LFI #26 S1 -  $\text{Sqrt} [ (dV1)^2 + (dV2)^2 ]$

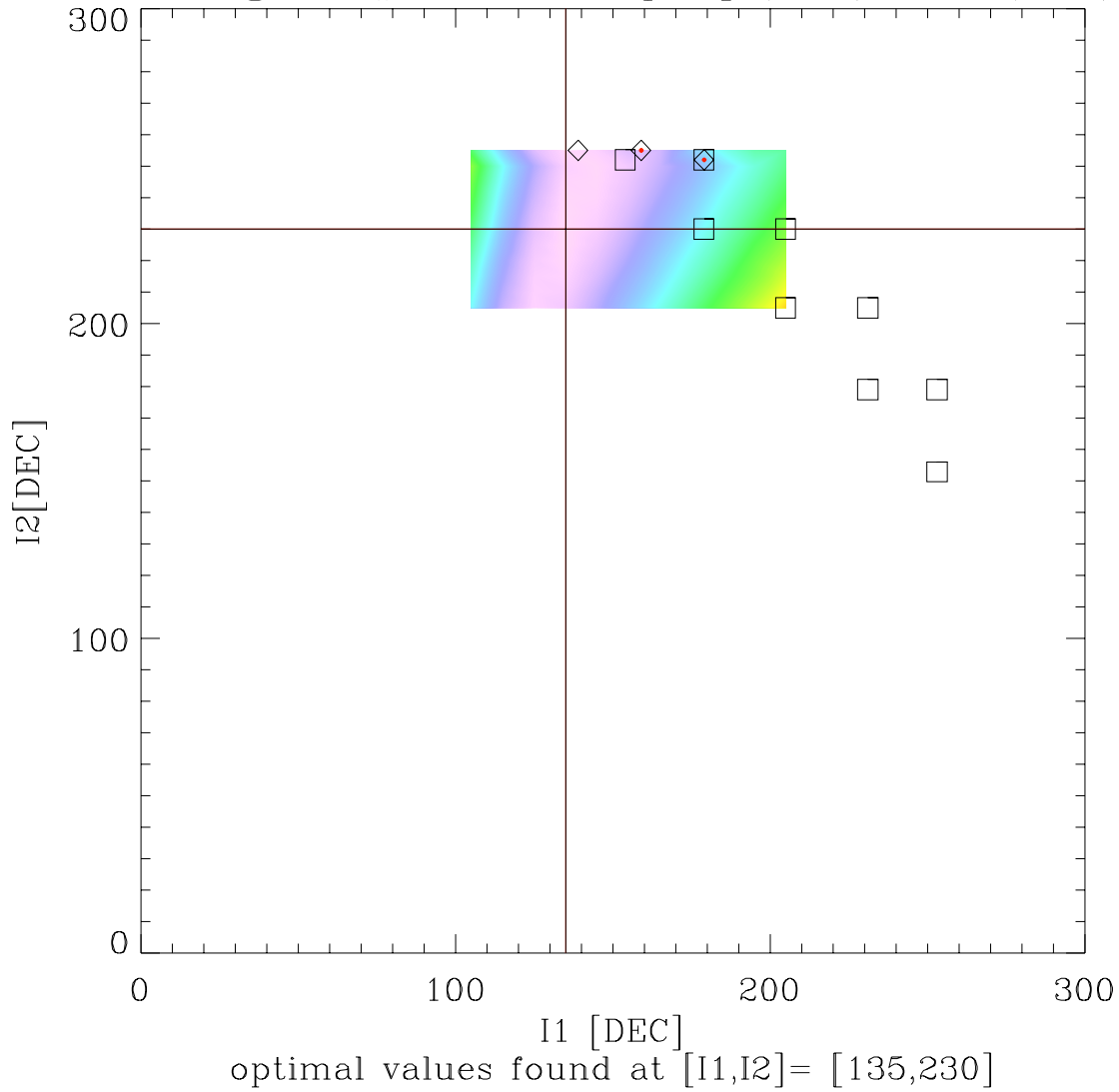



PSW Tuning LFI #26 S2 -  $\text{Sqrt} [ (dV1)^2 + (dV2)^2 ]$

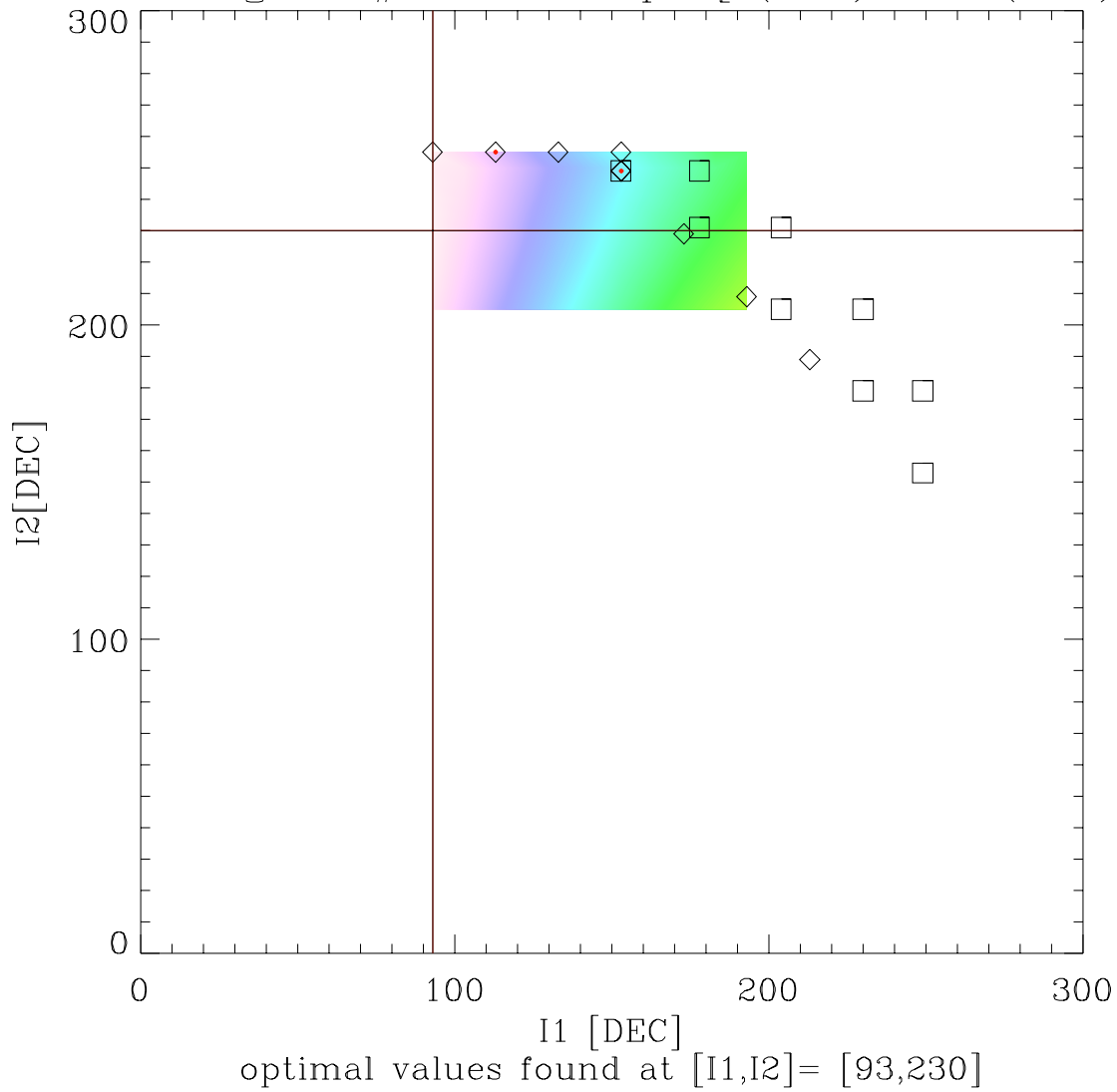



#### 7.4 RCA27 Contour Plots

PSW Tuning LFI #27 M1 -  $\text{Sqrt} [ (dV1)^2 + (dV2)^2 ]$

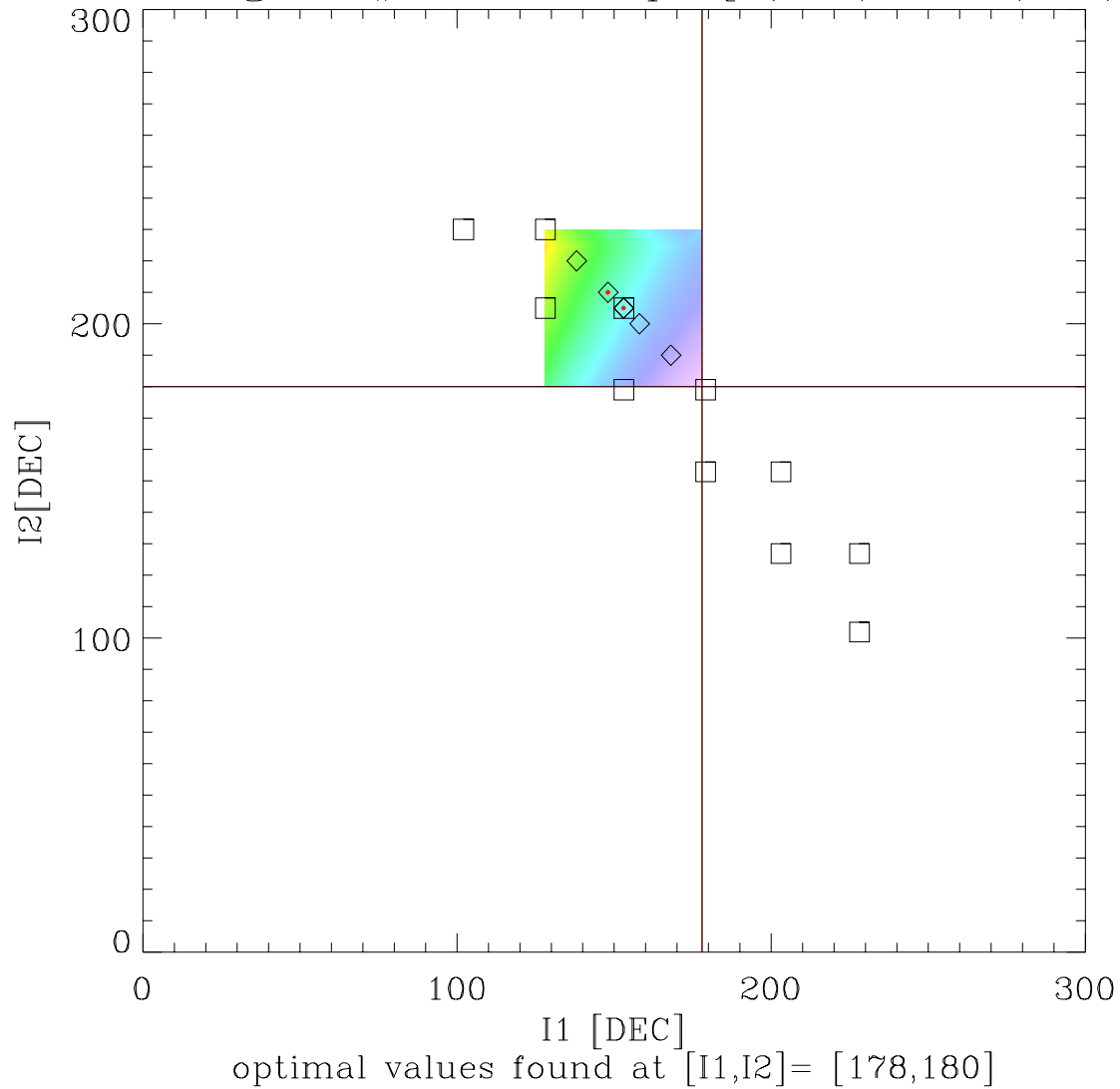



PSW Tuning LFI #27 M2 -  $\text{Sqrt} [ (dV1)^2 + (dV2)^2 ]$

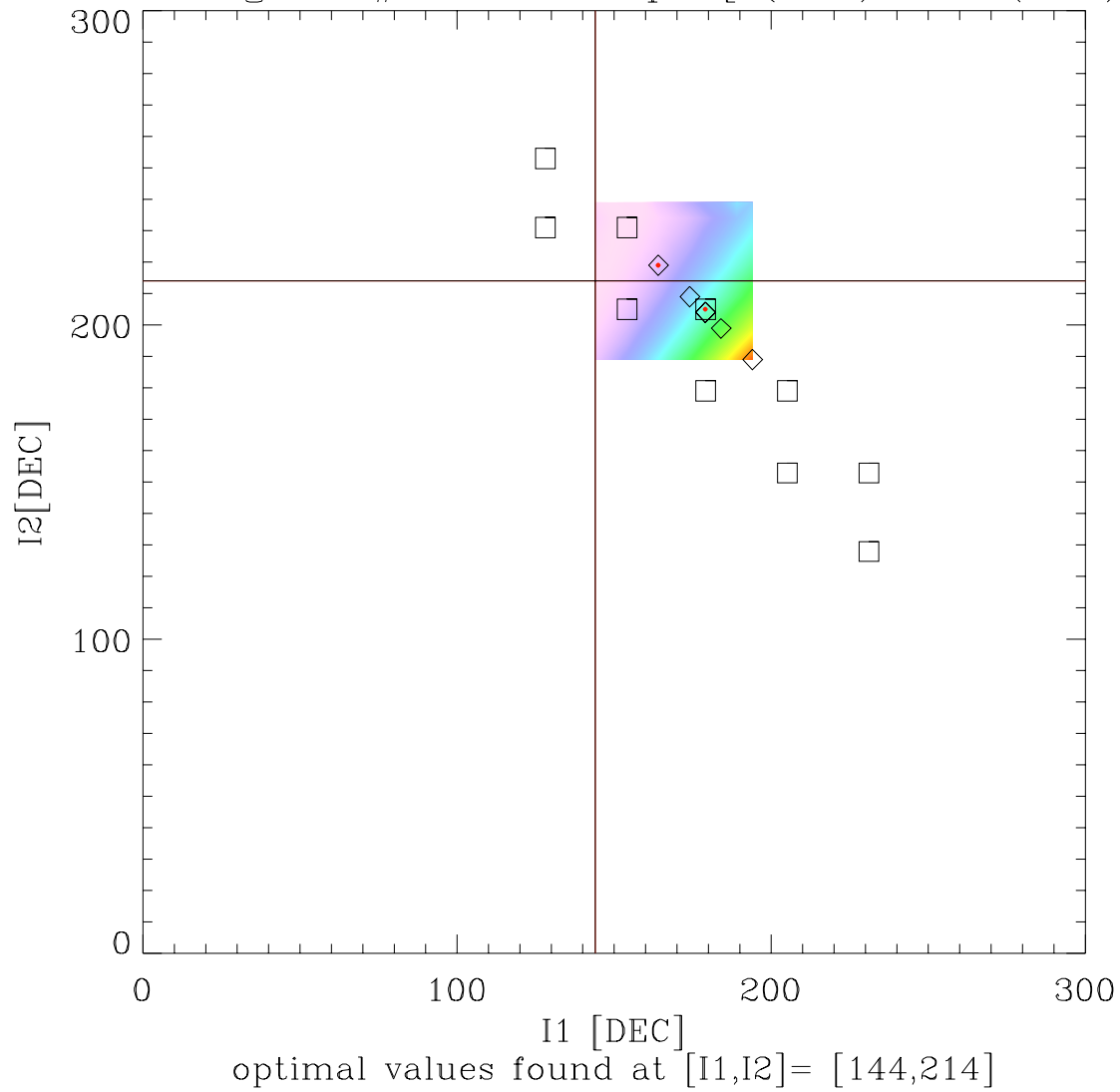



PSW Tuning LFI #27 S1 -  $\text{Sqrt} [ (dV1)^2 + (dV2)^2 ]$

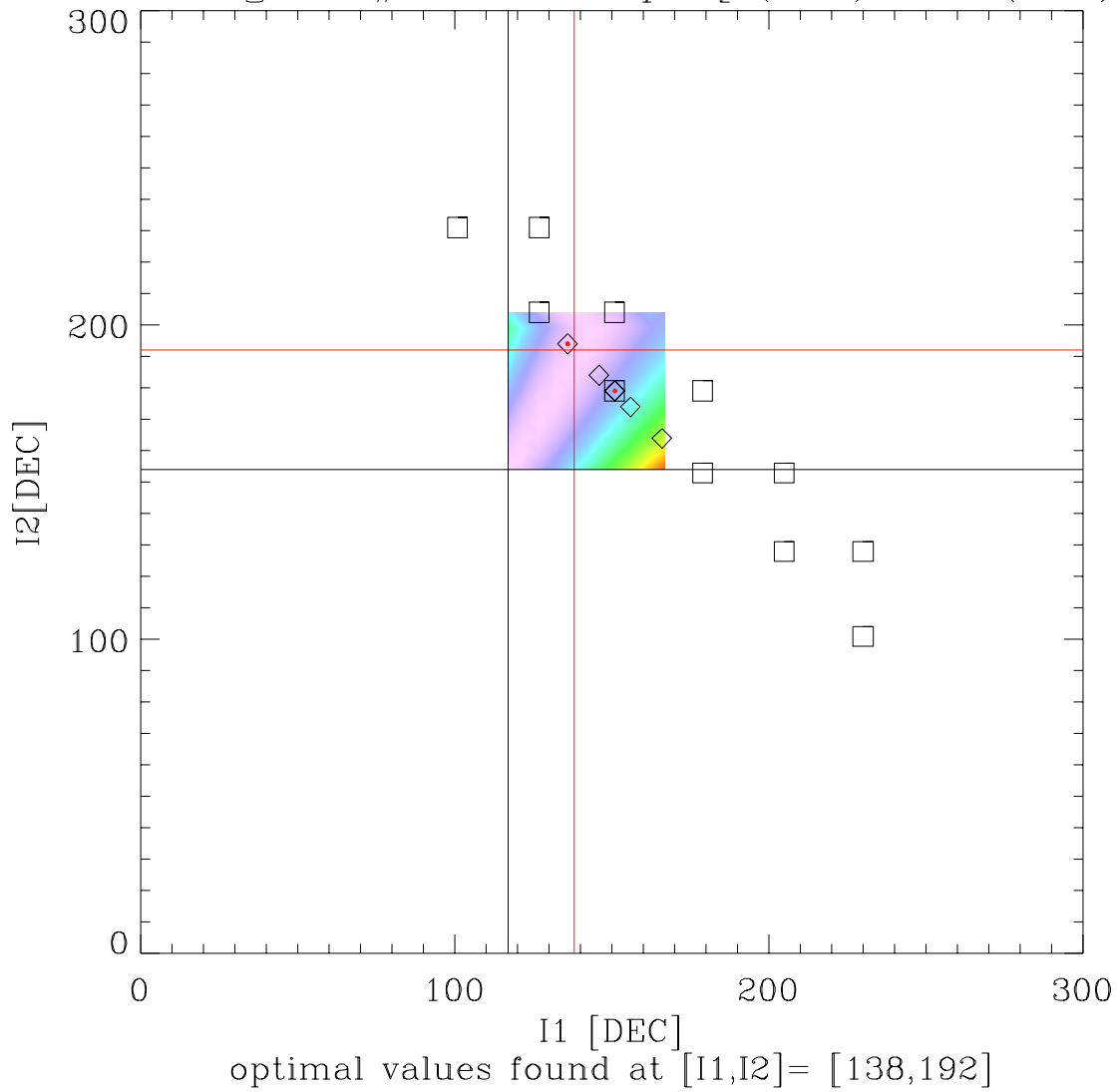



PSW Tuning LFI #27 S2 -  $\text{Sqrt} [ (dV1)^2 + (dV2)^2 ]$

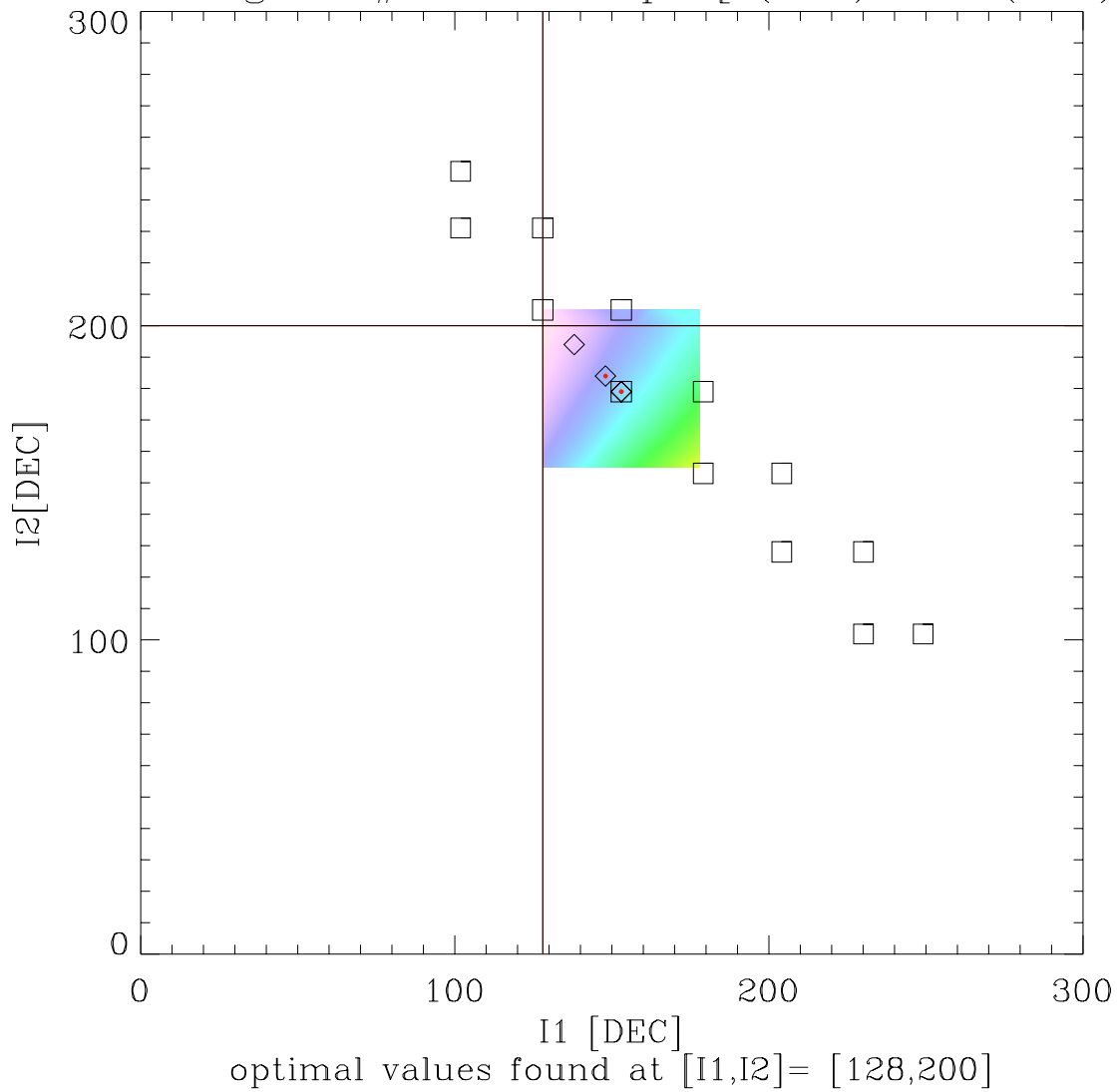



### 7.5 RCA28 Contour Plots

PSW Tuning LFI #28 M1 -  $\text{Sqrt} [ (dV1)^2 + (dV2)^2 ]$

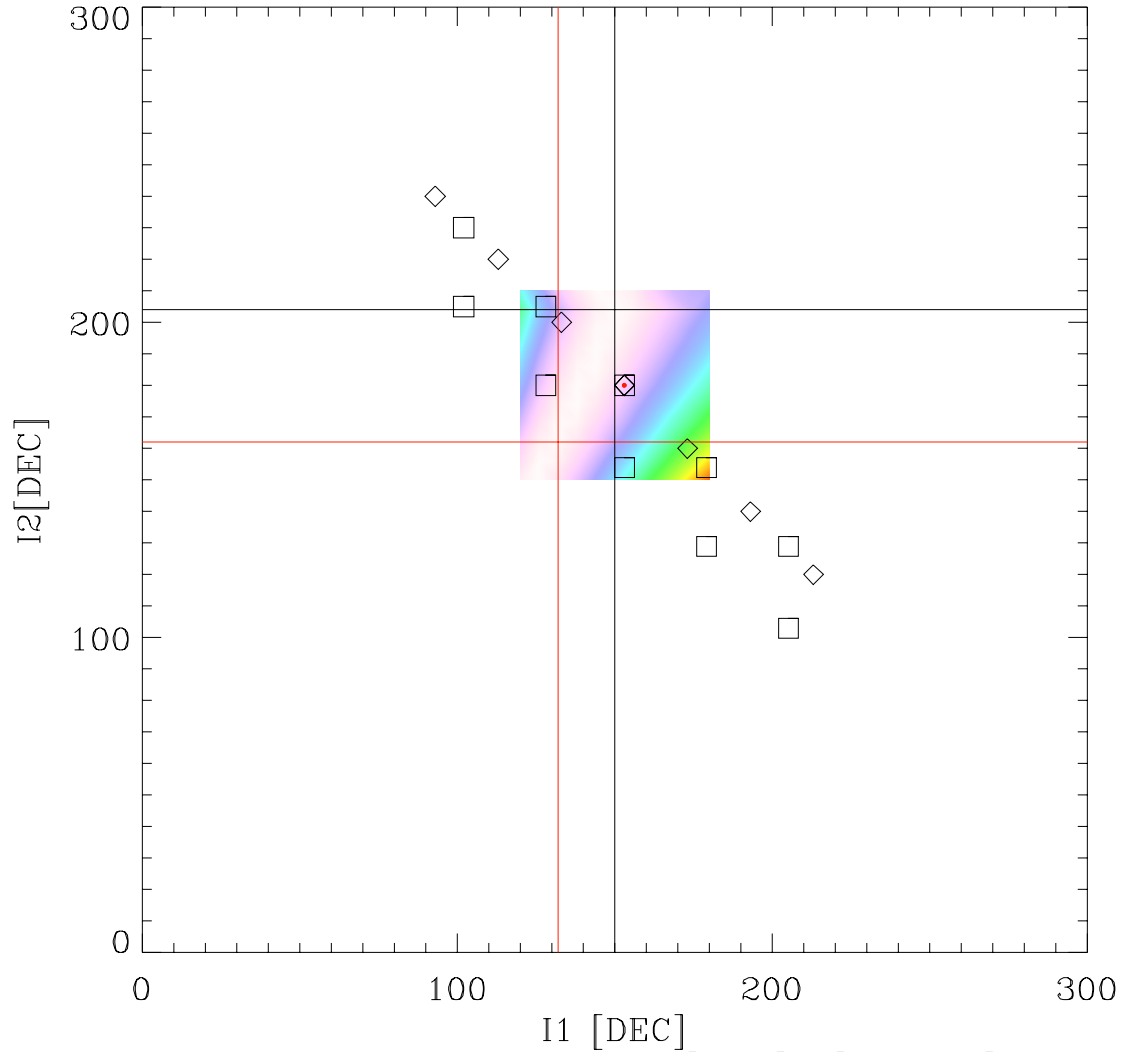

optimal values found at  $[I1, I2] = [132, 162]$



PSW Tuning LFI #28 M2 -  $\text{Sqrt} [ (dV1)^2 + (dV2)^2 ]$

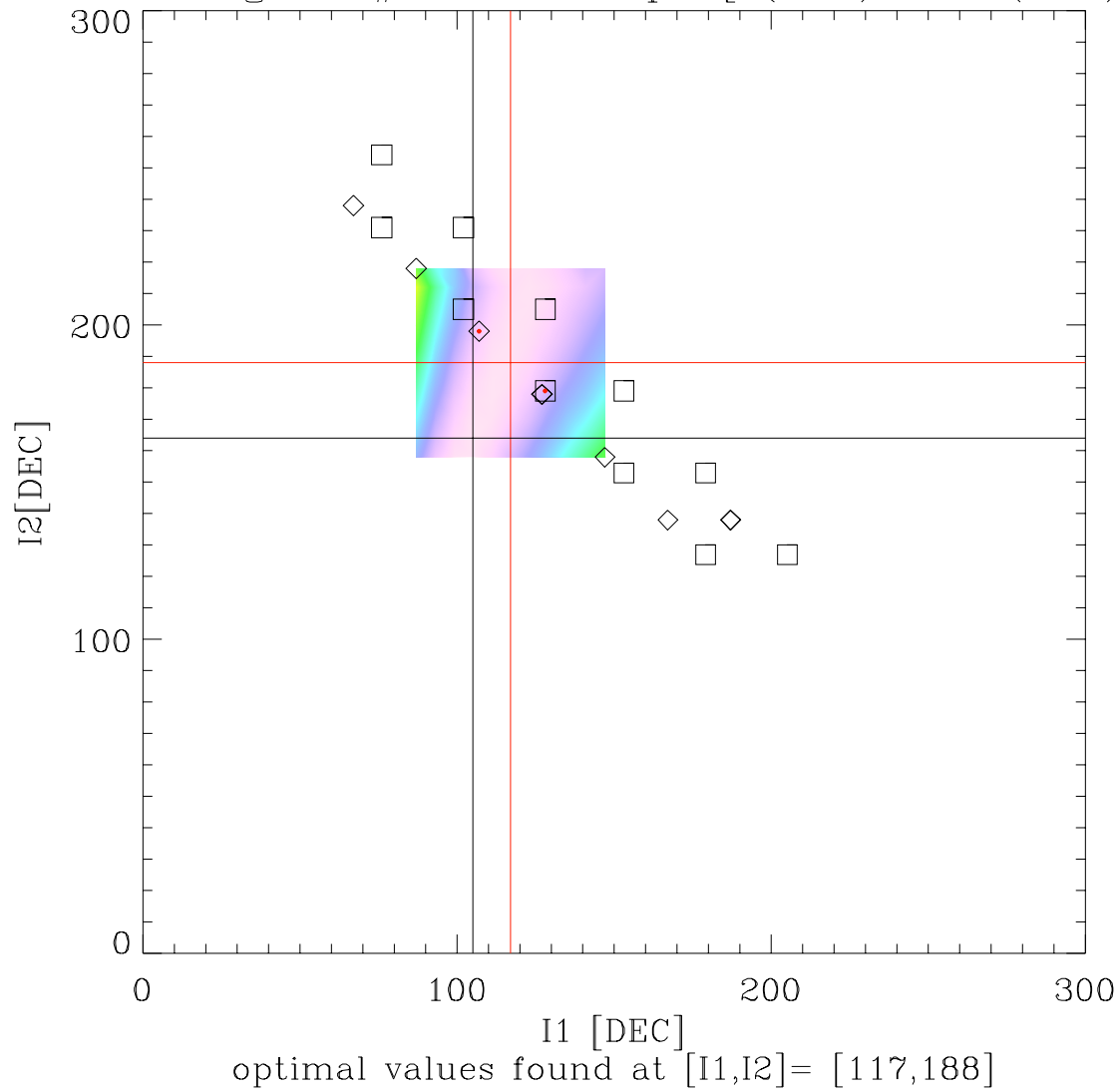



PSW Tuning LFI #28 S1 -  $\text{Sqrt} [ (dV1)^2 + (dV2)^2 ]$

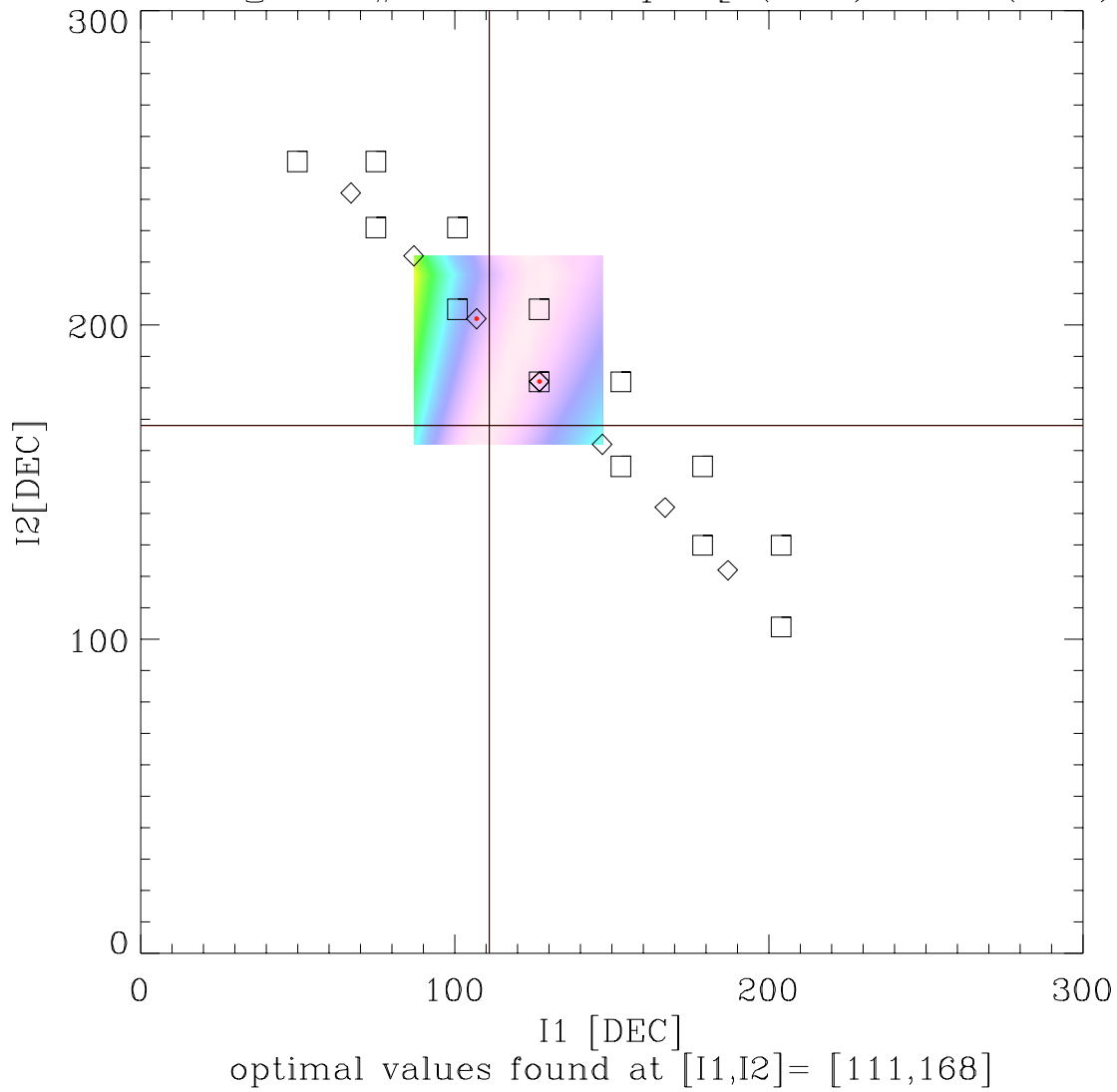



PSW Tuning LFI #28 S2 -  $\text{Sqrt} [ (dV1)^2 + (dV2)^2 ]$

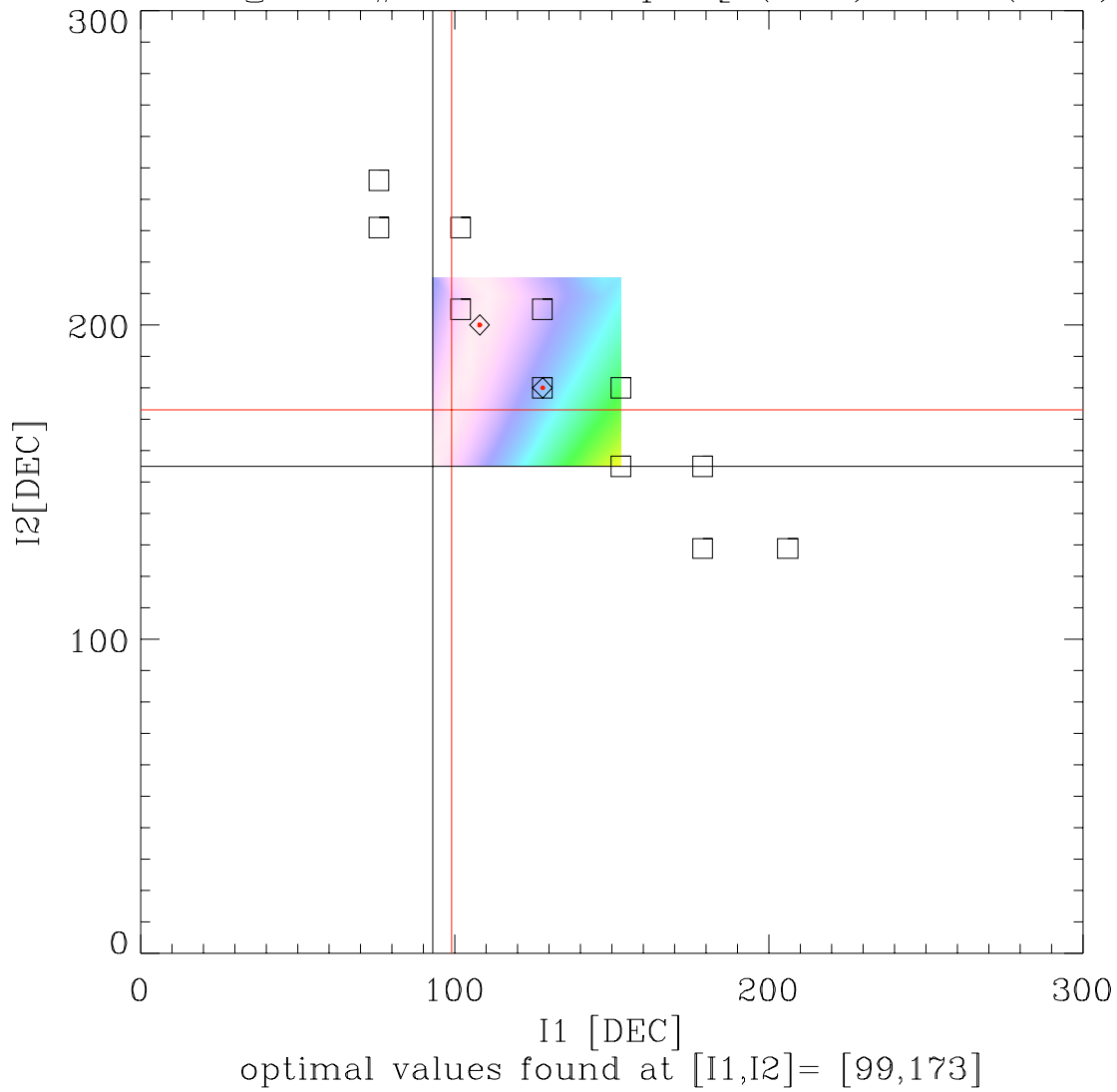



## 7.6 COMMENTS

There are still problems in data analysis which are not depending on the analysis script and routines. All the plots show a systematic deviation of contour isolines toward the left direction in correspondence of the top points of the grid. Although this problem may affect the results, it has been seen that this is not the case except marginally for LFI25M1.

As readily seen in Figure 6 the last point of each set of 11 I2 points related to a given I1 value shows a “wrong” level.

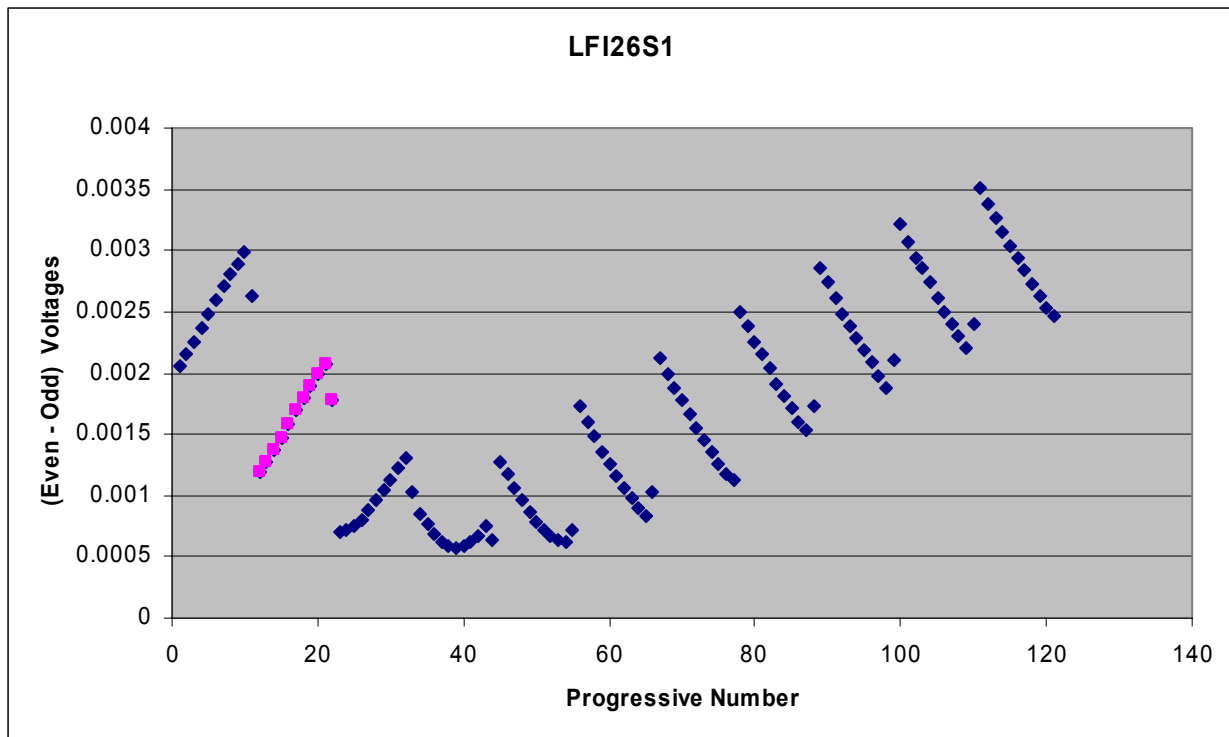

Figure 6: Typical (Even – Odd) signal coming from PSW tuning as a function of progressive number. Each set of 11 points is related to a fixed I1 value. As readily seen the last point of each set shows a “wrong” value

This problem can be understood by recalling the scanning strategy for matrix. Fixed a I1 value, I2 is varying (11 points) from low to high values. Then when the 11<sup>th</sup> point of I2 has been reached, I1 and I2 changes to scan another vertical line in the plane I1,I2.

While in a typical time window selected as the I1 and I2 remain constant the scientific signal does not vary very much presumably without invalidate the statistic (see



Figure 7 relative to the first magenta point of

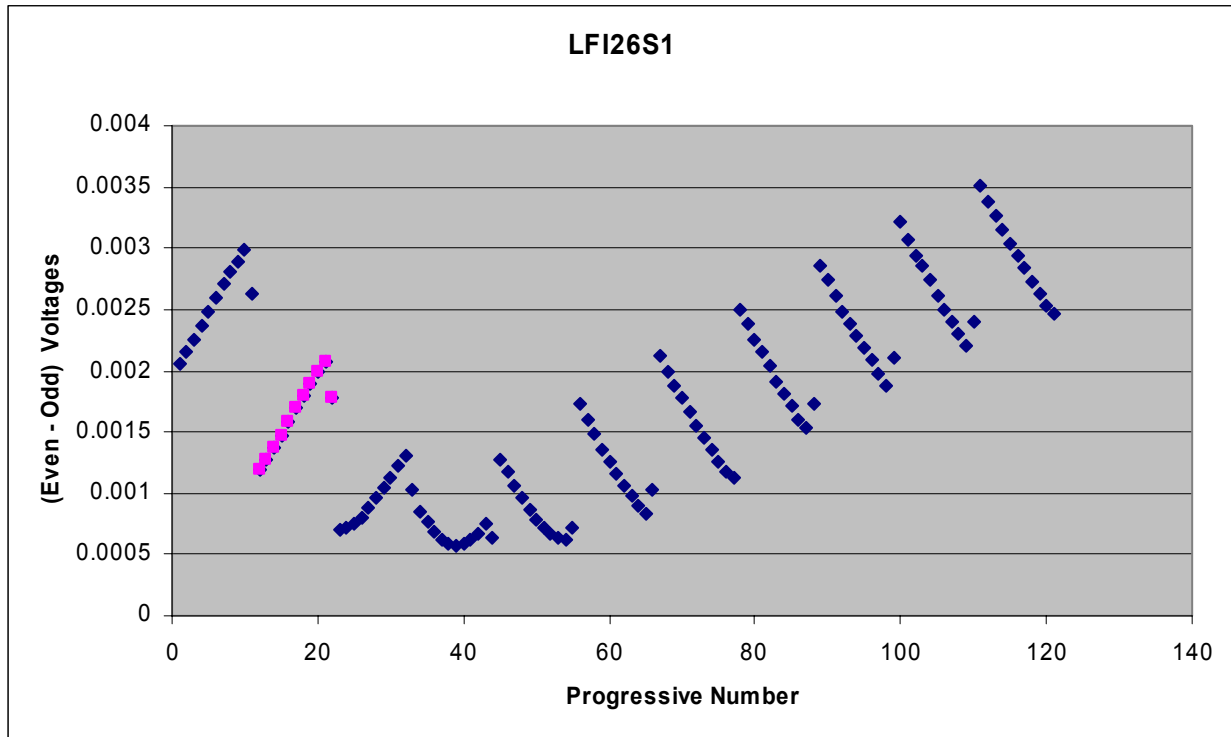

Figure 6, for the last point the scientific signal shows two big changes (see Figure 8 relative to the last magenta point of Figure 6 ) since both I1 and I2 changes asynchronously. Moreover it seems that the recorded HK points are not synchronous with changes. This effect is evident for last points since a big variation of I2 appears.

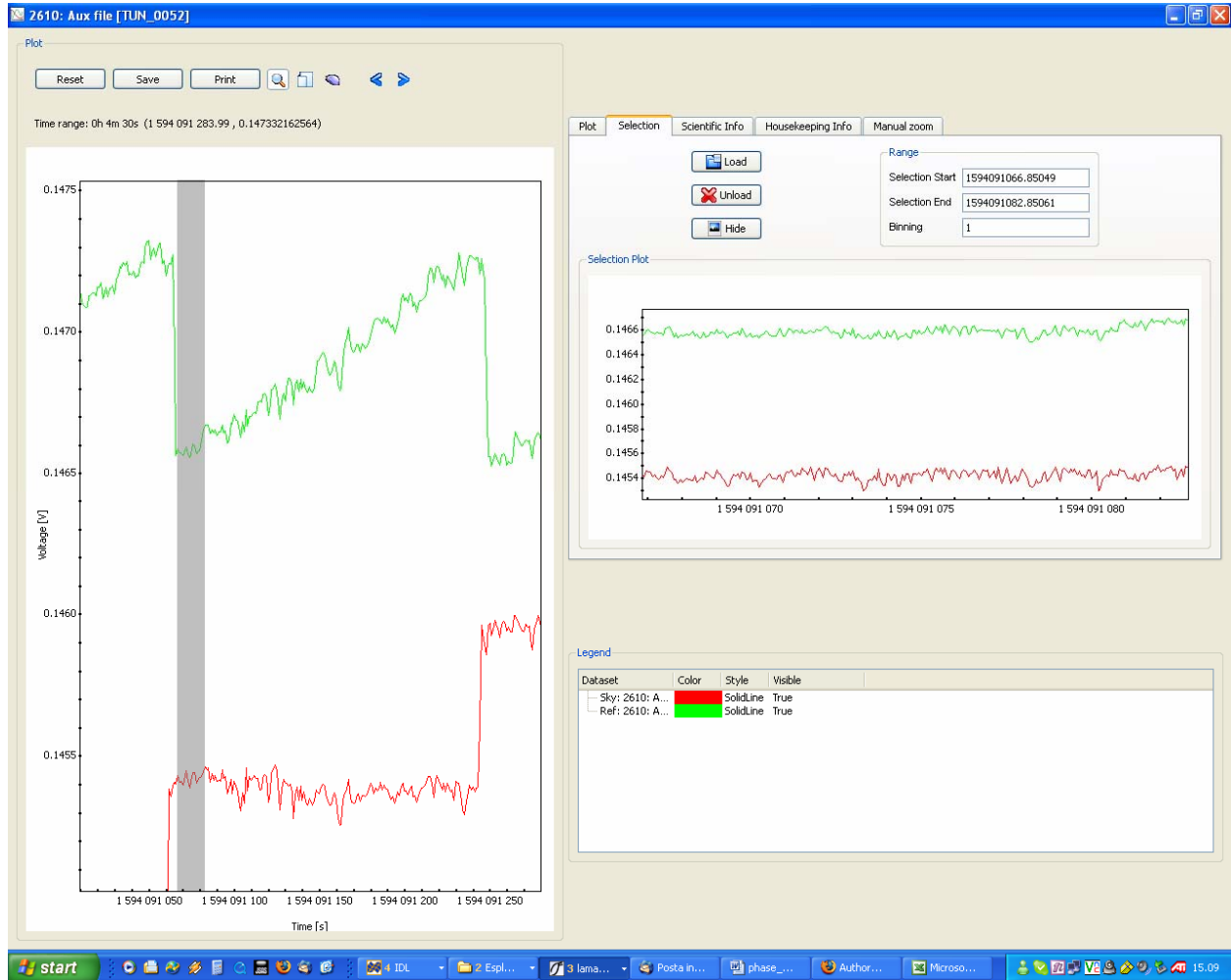

Figure 7: Scientific signal selected for a typical first point of each set of 11 I2 values. Note that the selection (plot on the right) does not show variation a big in the scientific signals (only a small variation on green curve is present).

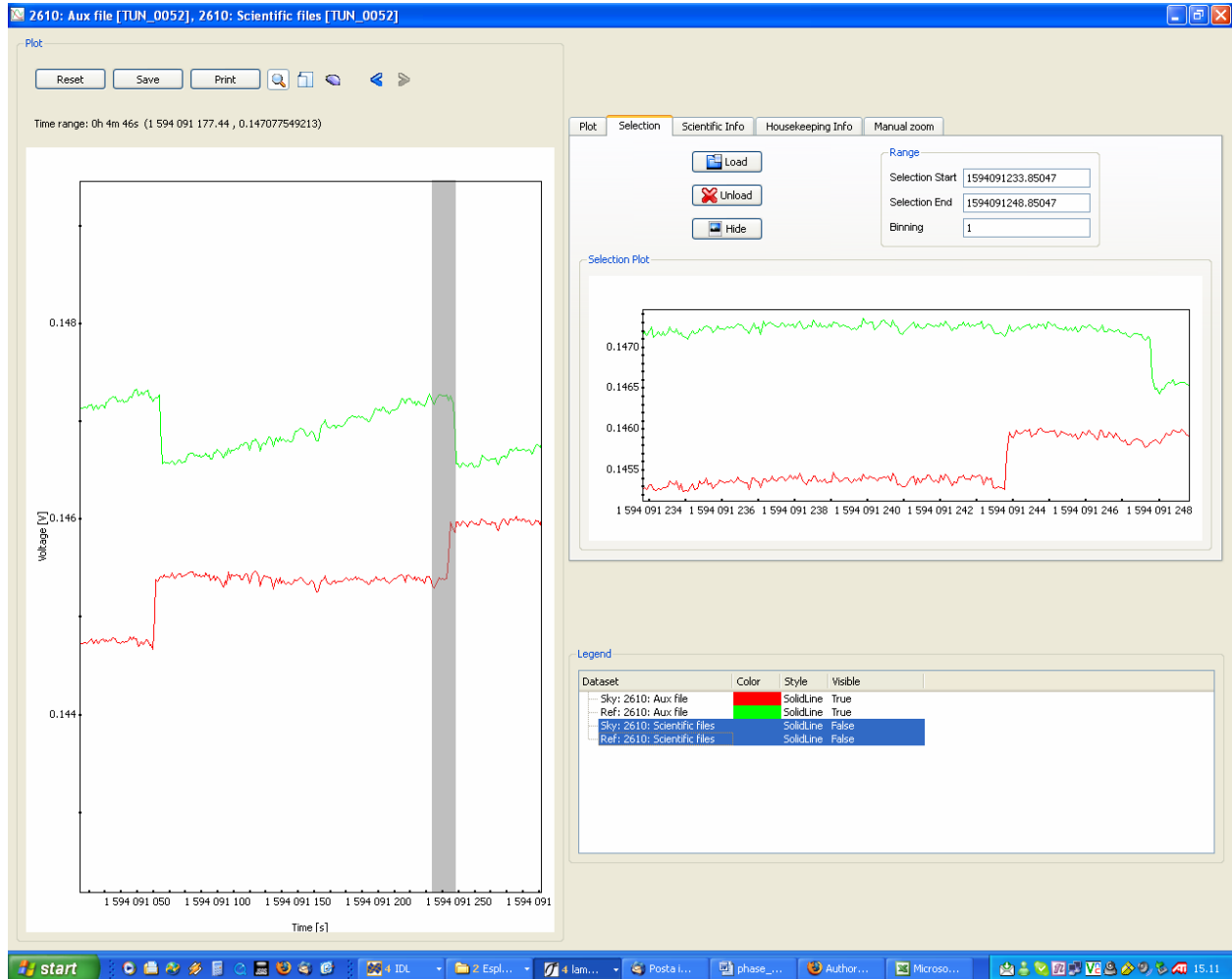

Figure 8: Scientific signal selected for a typical first point of each set of 11 I2 values. Note that the selection (plot on the right) shows big asynchronous variations in both scientific signals invalidating the statistics.

This problem needs to be further analysed in relation to decide the PSW tuning strategy for CPV phase. It is very difficult to correct this effect in the post processing data analysis since, as in this case, one should each time window manually. On the contrary **an appropriate study of the HK command synchronism with HK recording data will permit to decide the right tuning strategy for PSW during CPV phase.**



## 8 CONCLUSIONS

The PSW tuning verification has been performed successfully during LFI TV campaign. The test strategy (matrix tuning), different from the previous strategy, shows an undoubted advantage on the understanding of optimal PSW bias. It is recommended to follow this strategy also during CPV phase provided that the procedure will be modified to prevent the problem reported in chapter 7.6.

There are still differences in the results compared with the previous results (RAA and RCA), although a better understanding of PSW tuning is reached. The summary is reported here:

Table 3: Optimal bias (I1,I2) values as found in all the test performed

HORN ID	PSW ID	RAA		RCA		CSL (RUN 1)		CSL (RUN 2)	
		I1	I2	I1	I2	I1	I2	I1	I2
24	0 (M2)	91	255	127	253	91	255	77	205
	1 (M1)	152	252	152	230	128	250	128	250
	2 (S2)	96	255	126	250	86	215	86	215
	3 (S1)	87	234	127	252	84	235	84	235
25	0 (M1)	124	255	178	252	174	235	174	235
	1 (M2)	89	255	153	253	89	250	89	250
	2 (S1)	93	255	153	252	93	255	89	250
	3 (S2)	121	255	153	249	119	225	119	225
26	0 (M2)	136	255	153	253	153	210	153	210
	1 (M1)	118	255	178	230	98	245	98	245
	2 (S2)	114	255	153	249	93	230	93	230
	3 (S1)	159	255	179	252	135	230	135	230
27	0 (M1)	148	210	153	205	178	180	178	180
	1 (M2)	169	214	179	205	144	214	144	214
	2 (S1)	138	192	151	179	138	192	117	154
	3 (S2)	148	184	153	179	128	200	128	200
28	0 (M1)	153	180	153	180	132	162	150	204
	1 (M2)	101	204	128	179	117	188	105	164
	2 (S1)	112	197	127	182	111	168	111	168
	3 (S2)	108	200	128	180	99	173	93	155



Table 4: Relative comparison for optimal bias (I1,I2) values. Percentage has been calculate as (CSL-previous test)/(previous test) \*100. The column 'comments' reports the qualitative evaluation of the agreement between CSL and previous tests based on comparison plots as in chapter 7. The qualitative evaluation takes into account also the different scanning methods.

HORN ID	PSW ID	CSL Run 1		CSL Run 2		Comments	CSL Run1		CSL Run2		Comments
		Vs RAA		Vs RAA			Vs RCA		Vs RCA		
		%	%	%	%		%	%	%	%	
24	0 (M2)	0	0	15	20	Yes	28	1	39	19	No
	1 (M1)	16	1	16	1	No	16	9	16	9	Yes
	2 (S2)	10	16	10	16	Marginal	32	14	32	14	No
	3 (S1)	3	0	3	0	No	34	7	34	7	No
25	0 (M1)	40	8	40	8	No	2	7	2	7	Yes
	1 (M2)	0	2	0	2	Yes	42	1	42	1	Yes
	2 (S1)	0	0	4	2	Yes	39	1	42	1	Yes
	3 (S2)	2	12	2	12	Yes	22	10	22	10	Yes
26	0 (M2)	13	18	13	18	No	0	17	0	17	No
	1 (M1)	17	4	17	4	Yes	45	7	45	7	No
	2 (S2)	18	10	18	10	Marginal	39	8	39	8	Yes
	3 (S1)	15	10	15	10	Marginal	25	9	25	9	No
27	0 (M1)	20	14	20	14	No	16	12	16	12	No
	1 (M2)	15	0	15	0	Yes	20	4	20	4	No
	2 (S1)	0	0	15	20	Yes	9	7	23	14	Marginal
	3 (S2)	14	9	14	9	No	16	12	16	12	No
28	0 (M1)	14	10	2	13	Marginal	14	10	2	13	Marginal
	1 (M2)	16	8	4	20	Marginal	9	5	18	8	No
	2 (S1)	1	15	1	15	Marginal	13	8	13	8	No
	3 (S2)	8	14	14	23	Yes	23	4	27	14	No