



<b>Publication Year</b>	2022
<b>Acceptance in OA</b>	2023-02-14T17:30:37Z
<b>Title</b>	Ariel payload harness thermal analysis
<b>Authors</b>	MORGANTE, GIANLUCA
<b>Handle</b>	<a href="http://hdl.handle.net/20.500.12386/33469">http://hdl.handle.net/20.500.12386/33469</a>
<b>Volume</b>	ARIEL-INAF-PL-TN-005

## Electronic Signature Page

**Title:** PLM Harness Thermal Analysis

**Reference:** ARIEL-INAF-PL-TN-005

**Issue:** 4.0

<b>Signed By</b>	<b>Approval Date</b>	<b>Signature</b>
Gianluca Morgante (INAF)	16-09-2022 08:30	Electronically approved by Gianluca Morgante via DCCM document approval process
Paul Eccleston (RAL SPACE)	16-09-2022 08:53	Electronically approved by Paul Eccleston via DCCM document approval process
Alexander Davidson (RAL SPACE)	16-09-2022 08:58	Electronically approved by Alexander Davidson via DCCM document approval process
Andrew Caldwell (RAL SPACE)	16-09-2022 15:18	Electronically approved by Andrew Caldwell via DCCM document approval process
Mauro Focardi (INAF)	16-09-2022 08:28	Electronically approved by Mauro Focardi via DCCM document approval process

The controlled copy of this document is available to authorised ECLIPSE users at:

<https://ral.sapienza-eclipse.com>



Ariel Payload  
Consortium

PLM Harness Thermal  
Analysis

Doc Ref: ARIEL-INAF-PL-TN-005  
Issue: 4.0  
Date: 14 September 2022

# Atmospheric Remote-sensing Infrared Exoplanet Large survey

## Ariel PLM Harness Thermal Analysis

**ARIEL-INAF-PL-TN-005**  
**Issue 4.0**

Prepared by: \_\_\_\_\_  
G. Morgante (INAF-OAS Bologna)

*PLM Thermal System Engineer*

Date: 14.09.2022

Reviewed by: \_\_\_\_\_  
*PLM System Engineer Team*

Date: \_\_\_\_\_

Approved by: \_\_\_\_\_  
*PLM Project Management*

Date: \_\_\_\_\_

	Ariel Payload Consortium	PLM Harness Thermal Analysis	Doc Ref: ARIEL-INAF-PL-TN-005 Issue: 4.0 Date: 14 September 2022
---	-----------------------------	---------------------------------	--

## DOCUMENT CHANGE RECORD

Issue	Date	Page	Description Of Change	Comment
0.1	26-Jan-2017	All	First draft for internal comments	
0.2	01-Feb-2017	All	First draft circulated	
1.0	14-Feb-2017	All	Release of the document for MSR	
2.0	19-Feb-2020	All	Release of the document for PLM SRR	
3.0	06-Sep-2022	All	General revision for pPDR	
4.0	14-Sep-2022	All	Up issue after internal approval process	

	Ariel Payload Consortium	PLM Harness Thermal Analysis	Doc Ref: ARIEL-INAF-PL-TN-005 Issue: 4.0 Date: 14 September 2022
---	-----------------------------	---------------------------------	--

## TABLES OF CONTENTS

### LIST OF CONTENTS

Document Change Record .....	ii
Tables of Contents .....	iii
List of Contents .....	iii
List of Tables .....	iv
List of Figures .....	v
1 Introduction .....	6
1.1 Applicable Documents .....	6
1.2 Reference Documents .....	6
2 ARIEL PLM Harness configuration .....	7
2.1 Material properties assumptions .....	9
3 ARIEL cryo-harness baseline proposal .....	11
3.1 Detectors Control Harness .....	11
3.1.1 AIRS Detectors cabling .....	11
3.1.1.1 <i>Bundle 1 - AIRS CFEE bias/output:</i> .....	11
3.1.1.2 <i>Bundle 2 - AIRS CFEE clock:</i> .....	12
3.1.1.3 <i>Bundle 3 - AIRS CFEE Thermal Control:</i> .....	12
3.1.2 FGS Detectors cabling .....	13
3.1.2.1 <i>Bundle 1 - PIP (DCU) &lt;-&gt; FPE Control:</i> .....	13
3.1.2.2 <i>Bundle 2 - PIP (TCU) &lt;-&gt; FPE Thermal Control:</i> .....	14
3.1.2.3 <i>Bundle 3 - PIP (TCU) &lt;-&gt; FCB Thermal Control:</i> .....	14
3.1.3 PLM Thermal Control Harness .....	14
3.1.3.1 <i>TCU thermistors</i> .....	16
3.1.3.2 <i>Decontamination lines (heaters + thermistors)</i> .....	17
3.1.3.3 <i>Survival lines</i> .....	17
3.2 Grounding lines .....	18
3.3 M2M cryo harness .....	18

	Ariel Payload Consortium	PLM Harness Thermal Analysis	Doc Ref: ARIEL-INAF-PL-TN-005 Issue: 4.0 Date: 14 September 2022
---	-----------------------------	---------------------------------	--

4	Total cryo harness heat fluxes.....	19
5	Acknowledgments .....	21

## LIST OF TABLES

Table 1.	Applicable Documents.....	6
Table 2.	Reference Documents.....	6
Table 3.	Materials thermal conductivity assumptions .....	9
Table 4.	Materials electrical resistivity assumptions .....	9
Table 5.	Wire gauge value used for the thermal analysis .....	9
Table 6.	Thermal leaks on stages for Bundle 1 .....	12
Table 7.	Thermal leaks on stages for Bundle 2 .....	12
Table 8.	Thermal leaks on stages for Bundle 3 .....	13
Table 9.	Thermal leaks on stages for FGS Bundle 1 .....	13
Table 10.	Thermal leaks on stages for FGS Bundle 2.....	14
Table 11.	Thermal leaks on stages for FGS Bundle 3.....	14
Table 12.	Summary of PLM thermal control thermistors, wires and heatsinking stages .....	15
Table 13.	Summary of PLM thermal control heaters, wires and heatsinking stages .....	16
Table 14.	TCU thermistors (excluded the VGroove ones) heat leaks .....	16
Table 15.	VGrooves thermistors/wires distribution.....	16
Table 16.	VG thermistors heat leaks .....	16
Table 17.	Decontamination thermistors heat leaks .....	17
Table 18.	Survival thermistors heat leaks .....	17
Table 19.	Ground lines heat leaks .....	18
Table 20.	M2M cryoharness heat leaks .....	18
Table 21.	Ariel PLM total heat leaks on the thermal stages.....	19

	Ariel Payload Consortium	<b>PLM Harness Thermal  Analysis</b>	Doc Ref: ARIEL-INAF-PL-TN-005 Issue: 4.0 Date: 14 September 2022
---	-----------------------------	--	--

**LIST OF FIGURES**

Figure 1. Ariel cryo-harness thermal scheme ..... 8

Figure 2. AIRS detectors control cryoharness assumptions ..... 11

	<p>ARIEL Payload Consortium</p>	<p>PLM Harness Thermal Analysis</p>	<p>Doc Ref: ARIEL-INAF-PL-TN-005 Issue: 4.0 Date: 14 September 2022</p>
--	-------------------------------------	---	---

## 1 INTRODUCTION

This document describes the results of the thermal analysis of the Ariel PLM harness. The evaluations reported in this Technical Note are based on assumptions derived from the present knowledge of the sub-systems architecture, scientific requirements and performances expected on the basis of previous experiments and results.

This is a living document that has the function to report the details of the PLM cables thermal analysis. It will follow the evolution of the harness design, characteristics and performances from the thermal point of view during the Ariel PLM design consolidation process. For this reason, it can be considered as a sort of Annex to the general Ariel PLM Thermal analysis Report ([RD2]).

### 1.1 APPLICABLE DOCUMENTS

AD #	APPLICABLE DOCUMENT TITLE	DOCUMENT ID
0	Ariel Terms, Definitions and Abbreviations	ARIEL-RAL-PL-LI-001
1	Ariel Mission Requirements Document	ESA-ARIEL-EST-MIS-RS-001
2	Ariel Payload Interface Definition – Part A (PID-A)	ESA-ARIEL-SC-RS-007

*Table 1. Applicable Documents*

### 1.2 REFERENCE DOCUMENTS

RD #	REFERENCE DOCUMENT TITLE	DOCUMENT ID
0	Ariel Payload Harnessing Diagram	ARIEL-RAL-PL-DW-006
1	Ariel Payload Design Description (PDD)	ARIEL-RAL-PL-DD-001
2	Ariel PLM Thermal Analysis Report	ARIEL-INAF-PL-TN-003
3	Ariel PLM Thermal ICD	ARIEL-INAF-PL-IF-002
4	AIRS Harness Design Description	ARIEL-CEA-INST-DD-002
5	Ariel FGS Cryoharness Design Description	ARIEL-CBK-INST-DD-003
6	Ariel M2M Cryo-harness Thermal Analysis	ARIEL-SEN-PL-AN-002
7	ACS Cryo-Harness Design and Analysis	ARIEL-RAL-PL-TN-035

*Table 2. Reference Documents*

	<p>ARIEL Payload Consortium</p>	<p>PLM Harness Thermal Analysis</p>	<p>Doc Ref: ARIEL-INAF-PL-TN-005 Issue: 4.0 Date: 14 September 2022</p>
--	-------------------------------------	---	---

## 2 ARIEL PLM HARNESS CONFIGURATION

The Ariel harness design is a key issue for the Instrument development, not only for the electrical performances but also for the thermal balance of the whole system. An optimized harness configuration shall be capable of ensuring minimal resistance and losses across the lines as well as the lowest heat leaks. Best electrical performances are achieved by using highly conductive materials that, on the other side, are very good thermal conductors. The harness design typical dilemma is how to combine these two conflicting requirements. An iterative trade-off effort at system level is in progress to define the final baseline configuration for the harness design. Here we present the results of the analysis of the thermal leaks on the PLM stages, based on the present status of the harness design prepared for the Ariel Payload Preliminary Design Review and on realistic assumptions for the thermal and electrical properties.

Due to the thermal configuration of the satellite, 6 main stages can be identified (Figure 1): the SVM, the VG's, the Telescope Assembly and Optical Bench, the 32-36K stage of the ACS for the AIRS detectors cooling. The main task of this living analysis is to provide the thermal point of view on the evolving cryoharness design, identify general guidelines and to propose a baseline configuration to minimize thermal leaks between such stages while ensuring electrical requirements.

Figure 1 shows a simplified scheme of the Ariel harness from the SVM to the PLM units. In the Ariel PLM two main groups of harness can be identified:

- Detectors (FPA & CFEE) control harness, including thermal control
- Harness for other subsystems control
  - PLM thermal control
  - JT cooler
  - M2 Mechanism
  - decontamination and survival

As shown in the picture the detector modules harness can be considered as composed by two main sections: the one connecting the Warm Electronics (WE) to the Sidecars (CFEE) and the cabling that links the CFEE to the FPA's. These two sections shall comply to different thermal/electrical requirements as the sidecars to detectors harness is typically limited to short lengths (< 0.3 m). For what concerns the detector control harness, this analysis is focused only on the cables connecting the Warm Electronics to the CFEE's and to the TA/TOB. The thermal configuration of flexi harness from CFEE's to FPA's, which is a critical unit for the electrical and thermal performance of the detector system, is under the responsibility of the FGS/AIRS module teams and is not discussed in this Technical Note.

From the thermal point of view, five sections of the detector modules harness can be identified between the main stages:

- Section 1 (CryoH1 SVM-VG1)
- Section 2 (CryoH2 VG1-VG2)
- Section 3 (CryoH3 VG2-VG3)
- Section 4 (CryoH4 VG3-TOB/IB)
- Section 5 (CryoH5 TOB-ACS CE), this section refers only to the cables reaching the ACS cold tip.

The cables run continuously across the stages and dissipate their parasitic heat loads to the VGrooves first and then on the TOB. Approximately 2 meters of harness are needed to connect PLM units to the Warm Electronics. Most of this length is isothermal though, as for example the connections between warm electronic units and the S/C in the SVM or the cabling that runs across the stages for thermalization. These sections (indicated with the resistor symbol in Figure 1) are not taken into account in this analysis as thermally not relevant. Only the sections of the cables that run across a thermal break, generating heat leaks between the stages, have been considered. On the other end, the electrical resistance of the lines is evaluated for the whole length of the cable, assumed here to be 2 m from the SVM to the TOB, a value that is easily scalable for the actual length of the different units.

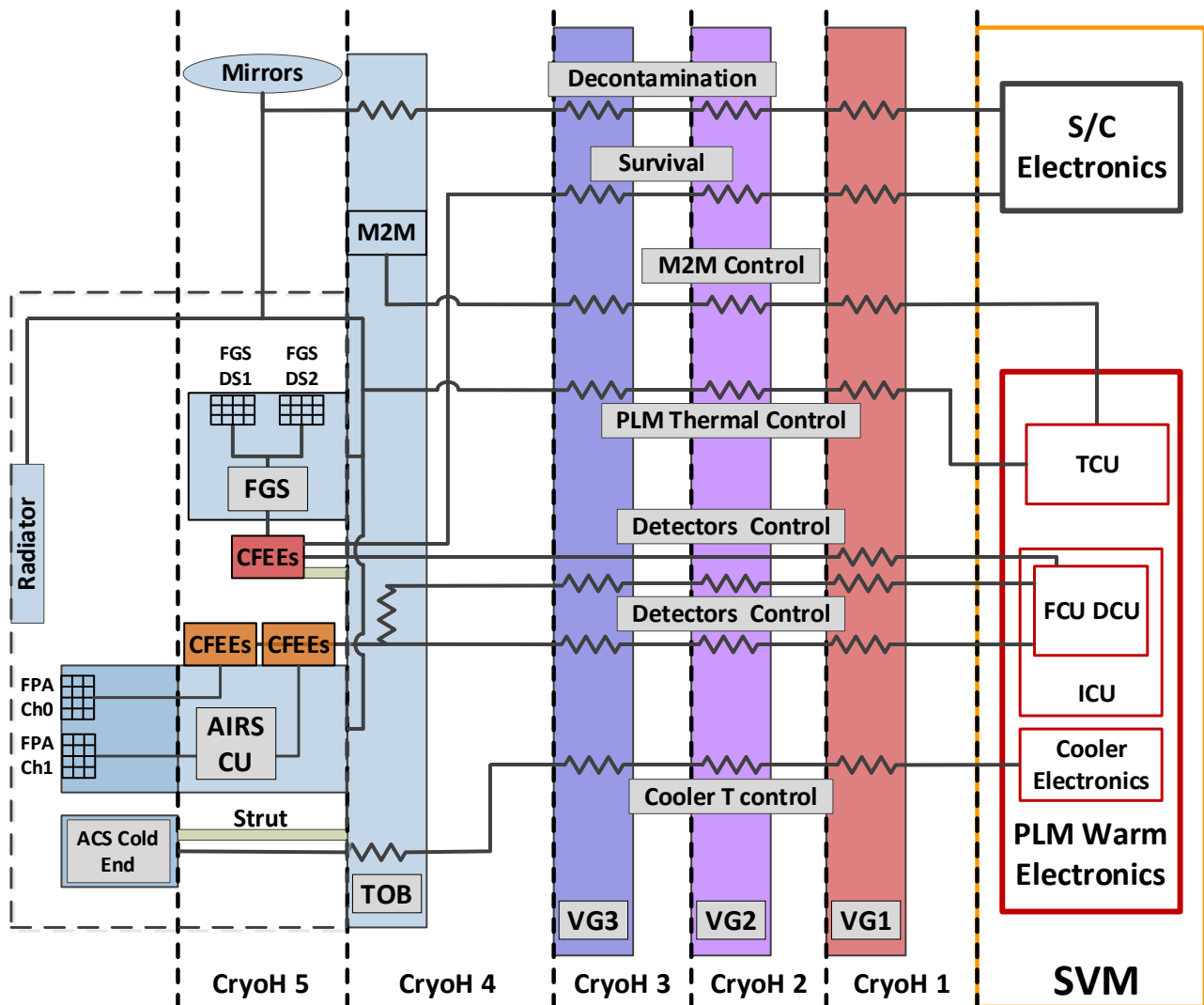

Figure 1. Ariel cryo-harness thermal scheme

The PLM cryo harness is described in more detail in a dedicated document [RD0] and its design is based on the presently assumed cables configuration of the detectors system, of the M2M and on number of thermistors and heaters for the thermal control, decontamination and survival lines.

In summary, at this stage, seven bundles of harness have been considered at the moment:

- Module detectors control/acquisition, from PIP connector interface to CFEES
- Detectors thermal control, from PIP connector interface to CFEES
- PLM thermal control, from PIP connector interface to the relevant units (VGs, TOB, mirrors, telescope baffle, instrument radiator)
- Decontamination and Survival lines
- ACS cold end control, from the TOB to the cold heat exchanger
- M2 Mechanism control, from the PIP interface to the M2M

The design and analysis of the cables internal to the module instruments (from the AIRS CFEE to the FPAs, from the FPEs to the FGS FOM FPAs) are assumed to be under responsibility of the instrument teams. The assumptions of this design are used as input in the general PLM GTMM to evaluate the heat leaks between the PLM and the modules.

The thermal stages temperatures for the present analysis are defined as follows (Figure 1):



- SVM at 293K (Hot thermal case)
- VGroove1 at 165K
- VG2 at 110K
- VG3 at 65K
- TOB, TA and Instrument Radiator considered as a single thermal stage, all at the same temperature of 60K

## 2.1 MATERIAL PROPERTIES ASSUMPTIONS

The thermal conductivity and electrical resistivity of the materials (with some margin) used in this analysis are reported in the following two tables:

**Table 3. Materials thermal conductivity assumptions**

<b>k cond (w/mK)</b>	<b>290</b>	<b>165</b>	<b>110</b>	<b>65</b>	<b>32</b>
<b>Cu</b>	387.97	396.97	420.87	600.20	991.28
<b>PCuSn</b>	41.38	33.53	28.89	21.36	13.17
<b>SS (304)</b>	14.78	11.18	9.23	6.62	3.72
<b>CuZn (brass)</b>	120.00	85	70	40	30
<b>PTFE</b>	0.27	0.26	0.24	0.22	0.18
<b>Kapton</b>	0.76	0.40	0.27	0.16	0.09

At present, the thermal contribution of the insulators (PTFE, Kapton) is assumed negligible with respect to the heat leaks due to the metallic conductors. Once the design of the cryoharness will be upgraded to indicate the final dimensions, configuration and material of the insulators, this assumption shall be reviewed.

**Table 4. Materials electrical resistivity assumptions**

<b>rho (ohm-m)</b>	<b>300</b>	<b>150</b>	<b>100</b>	<b>50</b>	<b>30</b>
<b>Cu</b>	1,70E-08	7,00E-09	3,45E-09	5,00E-10	4,00E-10
<b>PCuSn</b>	1,04E-07	9,80E-08	9,40E-08	9,00E-08	8,90E-08
<b>SS (304)</b>	7,10E-07	6,20E-07	5,60E-07	5,10E-07	5,00E-07
<b>CuZn</b>	7,20E-08	5,60E-08	5,10E-08	4,60E-08	4,30E-08

The ohmic loads generated by Joule effect due to wires resistivity are not taken into account: given the small currents expected, even in the case of using CuZn and P-CuSn instead of Cu, it is possible to neglect that contribution at this stage of the study. The higher currents needed for decontamination and survival lines could generate significant heating due to Joule effect, if materials other than Cu are selected for these lines. In any case, these lines will be always activated in Off-Nominal conditions, so any possible significant heat dissipation along the cables will not affect the thermal performance of the mission. Any unbalance to the thermal status will be recovered before entering into Nominal Observation Mode. For this reason, a low conductivity material is assumed for the heating lines. At present, the proposed material is brass (CuZn) but a significantly less conductive material (e.g. stainless steel) can be selected, if needed to limit the heat leaks to the cold PLM.

The wire gauges considered in this analysis are summarized in the following table:

**Table 5. Wire gauge value used for the thermal analysis**

<b>AWG</b>	<b>Section</b>				<b>Diameter</b>			
<b>44</b>	0,00203	mm <sup>2</sup>	2,03E-09	m <sup>2</sup>	0,05083971	mm	5,1E-05	m



<b>38</b>	0,00797	mm <sup>2</sup>	7,97E-09	m <sup>2</sup>	0,101	mm	0,0001	m
<b>36</b>	0,0127	mm <sup>2</sup>	1,27E-08	m <sup>2</sup>	0,12716187	mm	0,00013	m
<b>34</b>	0,0201	mm <sup>2</sup>	2,01E-08	m <sup>2</sup>	0,16	mm	0,00016	m
<b>32</b>	0,032	mm <sup>2</sup>	3,2E-08	m <sup>2</sup>	0,2018506	mm	0,0002	m
<b>30</b>	0,0509	mm <sup>2</sup>	5,09E-08	m <sup>2</sup>	0,25457394	mm	0,00025	m
<b>28</b>	0,081	mm <sup>2</sup>	8,1E-08	m <sup>2</sup>	0,32114234	mm	0,00032	m
<b>26</b>	0,129	mm <sup>2</sup>	1,29E-07	m <sup>2</sup>	0,40527509	mm	0,00041	m

Again, these assumptions shall be reviewed once the cryoharness design and routing will be in a more consolidated configuration.

### 3 ARIEL CRYO-HARNESS BASELINE PROPOSAL

The cryo harness design is based on the scheme of Figure 1 and on the following assumptions:

- the general Ariel PLM cryoharness design description [RD0]
- the main specifications reported in the PLM Thermal ICD and in the available instruments harness design description documents ([RD3], [RD4], [RD5], [RD6], [RD7])
- the materials reported in Table 3
- a perfect heat sink at each stage (an assumption to be reviewed once the design of the heat sinking solution on the VG stages will be progressed)
- for the thermistors (both for PLM thermal control and decontamination/survival) a readout scheme on 4-wires twisted quads is assumed
- each cable has individual shielding, plus an extra overshield on the bundle
- the shielding thickness is assumed to be 0.12 mm with an outer diameter of 2 mm for each cable and 12 mm for each bundle
- all the harness cases shown below are based on a standard round bundle cable configuration (at this stage, flat cables are assumed only for the connection between CFEEs and detectors).

#### 3.1 DETECTORS CONTROL HARNESS

##### 3.1.1 AIRS DETECTORS CABLING

The thermal design of the cryo harness for the AIRS detector control is based on the specs reported in [RD4] and is summarized in the following Figure:

Channel									
	Function	Connector	Type of Cable	Number of cables	Wire Type	Max Wire Resistance		Num. of Connector	Connector Type
Bundle 1	cFEE I/F Outputs	J01	P-CuSn Shielded Pairs	3	AWG 30	100	Routed in the same bundle	1	37
			P-CuSn Shielded Quads	3	AWG 30	100			
			Cu Shielded Quads	1	AWG 28	1			
Bundle 2	cFEE I/F Clock	J02	P-CuSn Shielded Quads	4	AWG 28	10/100	Routed in the same bundle	1	25
			P-CuSn Shielded Pairs	2	AWG 28	10/100			
Bundle 3	Thermal Control	J03	P-CuSn Shielded Quads	12	AWG 30	10/100		1	62

**Figure 2. AIRS detectors control cryoharness assumptions**

Each channel CFEE is connected to the PIP connector bracket by means of three bundles with, respectively, 37, 25 and 62 pins.

The assumptions for each bundle are reported here below.

##### 3.1.1.1 Bundle 1 - AIRS CFEE bias/output:

- 37 pins connector
- 1 Copper shielded twisted quad, AWG 28, max wire R = 1 Ohm



- 3 Ph-CuSn shielded twisted pairs, AWG 30, max wire R = 100 Ohm
- 3 Ph-CuSn shielded twisted quads, AWG 30, max wire R = 100 Ohm
- Approx. length = 200 cm
- At present a SS braid shielding jacket is assumed for each cable, with thickness = 120 um with an outer diameter of 2 mm for each cable and 12 mm for each bundle

**Table 6. Thermal leaks on stages for Bundle 1**

No. of units	N	Wire material	293-165 [W]	165-110 [W]	110-65 [W]	65-60 [W]
1 TSQ <sup>1</sup>	4	Cu	0,1085	0,0486	0,0496	0,0072
3xTSP <sup>1</sup> +3xTSQ	18	PCuSn	0,0293	0,0105	0,0069	0,0006
		<b>Total wires</b>	0,1378	0,0591	0,0565	0,0078
1	1800	<b>SS braid Overshield</b>	0,0405	0,0137	0,0087	0,0008
7	315	<b>SS Shields</b>	0,0496	0,0167	0,0106	0,0009
		<b>Total shields</b>	0,0900	0,0304	0,0193	0,0017
		<b>Total single cable</b>	0,2278	0,0895	0,0759	0,0095
		<b>Total load Cables (x2)</b>	0,4557	0,1790	0,1517	0,0189
		<b>Total load with 30% margin</b>	0,5924	0,2327	0,1972	0,0246

Note: <sup>1</sup> TSP = Twisted shielded pair; TSQ = Twisted Shielded Quad

### 3.1.1.2 Bundle 2- AIRS CFEE clock:

- 25 pins connector
- 2 Ph-CuSn shielded twisted pairs, AWG 28, max wire R = 10/100 Ohm
- 4 Ph-CuSn shielded twisted quads, AWG 28, max wire R = 10/100 Ohm
- Approx length = 200 cm
- At present a SS braid shielding jacket is assumed for each cable, with thickness = 120 um with an outer diameter of 2 mm for each cable and 12 mm for each bundle

**Table 7. Thermal leaks on stages for Bundle 2**

No of units	No of wires	Wire material	293-165 [W]	165-110 [W]	110-65 [W]	65-60 [W]
4xTSQ + 2xTSP	20	PCuSn	0,0518	0,0185	0,0122	0,0011
		<b>Total wires</b>	0,0518	0,0185	0,0122	0,0011
1	1800	<b>SS braid Overshield</b>	0,0405	0,0137	0,0087	0,0008
6	315	<b>SS Shields</b>	0,0425	0,0144	0,0091	0,0008
		<b>Total shields</b>	0,0830	0,0280	0,0178	0,0015
		<b>Total single cable</b>	0,1347	0,0466	0,0300	0,0026
		<b>Total load Cables (x2)</b>	0,2695	0,0931	0,0600	0,0052
		<b>Total load with 30% margin</b>	0,3503	0,1211	0,0780	0,0068

### 3.1.1.3 Bundle 3- AIRS CFEE Thermal Control:

- 62 pins connector
- 12 Ph-CuSn shielded twisted quads, AWG 30, max wire R = 10/100 Ohm

	<b>ARIEL Payload Consortium</b>	<b>PLM Harness Thermal Analysis</b>	Doc Ref: ARIEL-INAF-PL-TN-005 Issue: 4.0 Date: 14 September 2022
--	---------------------------------	-------------------------------------	--

- Approx. length = 200 cm
- At present a SS braid shielding jacket is assumed for each cable, with thickness = 120 um with an outer diameter of 2 mm for each cable and 12 mm for each bundle

**Table 8. Thermal leaks on stages for Bundle 3**

No of units	No of wires	Wire material	293-165 [W]	165-110 [W]	110-65 [W]	65-60 [W]
12 x TSQ	48	PCuSn	0,1243	0,0445	0,0293	0,0026
		<b>Total wires</b>	0,1243	0,0445	0,0293	0,0026
1	1800	SS braid Overshield	0,0405	0,0137	0,0087	0,0008
12	315	SS Shields	0,0850	0,0287	0,0182	0,0016
		<b>Total shields</b>	0,1255	0,0424	0,0269	0,0023
		<b>Total single cable</b>	0,2497	0,0869	0,0562	0,0049
		<b>Total load Cables (x2)</b>	0,4994	0,1737	0,1125	0,0099
		<b>Total load with 30% margin</b>	0,6493	0,2259	0,1462	0,0128

### 3.1.2 FGS DETECTORS CABLING

The thermal design of the FGS detectors control cryo harness is based on the specs reported in [RD5]. Each detector chain is connected to the PIP bracket by means of three bundles with, respectively, 51, 21 and 21 pins.

The assumptions for each bundle are reported here below.

#### 3.1.2.1 Bundle 1 - PIP (DCU) <-> FPE Control:

- 51 pins connector
- 12 Copper shielded twisted pairs, AWG 30, max wire R = 0.25 ohm
- Length 125 cm +/- 50%
- At present a SS braid shielding jacket is assumed for each cable, with thickness = 120 um with an outer diameter of 2 mm for each cable and 12 mm for each bundle

**Table 9. Thermal leaks on stages for FGS Bundle 1**

No of units	No of wires	Wire material	293-165 [W]	165-110 [W]	110-65 [W]	65-60 [W]
12 x TSP	24	Cu	0,4091	0,0130	0,0000	0,0000
		<b>Total wires</b>	0,4091	0,0130	0,0000	0,0000
1	1800	SS braid Overshield	0,0405	0,0010	0,0000	0,0000
12	315	SS Shields	0,0850	0,0020	0,0000	0,0000
		<b>Total shields</b>	0,1255	0,0030	0,0000	0,0000
		<b>Total single cable</b>	0,5346	0,0160	0,0000	0,0000
		<b>Total load Cables (x2)</b>	1,0692	0,0320	0,0000	0,0000
		<b>Total load with 50% margin</b>	1,6037	0,0481	0,0000	0,0000



### 3.1.2.2 Bundle 2 - PIP (TCU) <-> FPE Thermal Control:

- 21 pins connector
- 8 Ph-CuSn shielded twisted pairs, AWG 30, max wire R = 40 ohm
- Length 125 cm +/- 50%
- At present a SS braid shielding jacket is assumed for each cable, with thickness = 120 um with an outer diameter of 2 mm for each cable and 12 mm for each bundle

**Table 10. Thermal leaks on stages for FGS Bundle 2**

No of units	No of wires	Wire material	293-165 [W]	165-110 [W]	110-65 [W]	65-60 [W]
8 x TSP	16	PCuSn	0,0260	0,0007	0,0000	0,0000
		<b>Total wires</b>	0,0260	0,0007	0,0000	0,0000
1	1800	SS braid Overshield	0,0405	0,0010	0,0000	0,0000
8	315	SS Shields	0,0567	0,0014	0,0000	0,0000
		<b>Total shields</b>	0,0971	0,0023	0,0000	0,0000
		<b>Total single cable</b>	0,1232	0,0030	0,0000	0,0000
		<b>Total load Cables (x2)</b>	0,2463	0,0060	0,0000	0,0000
		<b>Total load with 30% margin</b>	0,3695	0,0090	0,0000	0,0000

### 3.1.2.3 Bundle 3 - PIP (TCU) <-> FCB Thermal Control:

- 21 pins connector
- 8 Ph-CuSn shielded twisted pairs, AWG 30, max wire R = 3.8 ohm
- Length 195 cm +/- 50%
- At present a SS braid shielding jacket is assumed for each cable, with thickness = 120 um with an outer diameter of 2 mm for each cable and 12 mm for each bundle

**Table 11. Thermal leaks on stages for FGS Bundle 3**

No of units	No of wires	Wire material	293-165 [W]	165-110 [W]	110-65 [W]	65-60 [W]
8 x TSP	16	PCuSn	0,0260	0,0093	0,0061	0,0005
		<b>Total wires</b>	0,0260	0,0093	0,0061	0,0005
1	1800	SS braid Overshield	0,0405	0,0137	0,0087	0,0008
12	315	SS Shields	0,0850	0,0287	0,0182	0,0016
		<b>Total shields</b>	0,1255	0,0424	0,0269	0,0023
		<b>Total single cable</b>	0,1515	0,0517	0,0331	0,0029
		<b>Total load Cables (x2)</b>	0,3030	0,1034	0,0661	0,0057
		<b>Total load with 30% margin</b>	0,4545	0,1551	0,0992	0,0086

### 3.1.3 PLM THERMAL CONTROL HARNESS

The PLM Thermal Control Cryo Harness is composed by [see RD3]:

- the PLM thermal monitoring lines, controlled by the TCU → 37 fully redundant thermistors (37N+37R)
- the decontamination lines → 3 x 7 = 21 thermistors in triple voting cross-strapped configuration

	<p>ARIEL Payload Consortium</p>	<p>PLM Harness Thermal Analysis</p>	<p>Doc Ref: ARIEL-INAF-PL-TN-005 Issue: 4.0 Date: 14 September 2022</p>
--	-------------------------------------	---	---

- the survival line → 3 fully redundant thermistors (3N+3R)

The thermal control harness connects thermistors to the TCU and thermistors + heaters to the S/C RIU. At present, thermistor readout is based on 4-wires measurement, also for the decontamination and survival lines (TBC): for this reason, the lines electrical resistance is less critical and more thermally insulating materials can be used. Heaters control, on the other side, will require lower resistivity to minimize power losses and Joule heating effects.

Assumptions:

- a thermal break length of 0.15 m is assumed in between stages
- Perfect thermal coupling to each stage
- Thermistors:
  - 37 Instrument thermistors, fully redundant (total is 74) in the cold PLM
  - 1 fully redundant cryocooler thermistor on the ACS cold tip assembly
  - 21 Decontamination thermistors
  - 6 Survival thermistors (3N + 3R)
  - Shielded twisted quads (TSQ), with over shielding, of AWG 36 P-CuSn wires
  - SS braid jacket shielding, around twisted quad/pairs (approx. 2 mm outer diameter) and cable bundle (approx. outer diameter 12 mm).
- Heating lines
  - 7N+7R heating lines for decontamination
  - 1N+1R heating line for survival
  - 1N+1R heating line for ACS cold tip orifice
  - 2 wires each with AWG30 CuZn wiring for a total of 12 wires
  - Shielded twisted pairs (SS braid jacket)

The ACS cryoharness thermal leaks are assumed to be dissipated on the cooler piping heat exchanger. In [RD7] it is shown that the residual heat flux leaked to the cold tip can be limited to less than 1 mW. For this reason, in this analysis, only the contribution of the decontamination heaters/thermistors that might be integrated on the cold tip stand-off for AIRS FPAs temperature control are considered. In any case, the need for a heating control line for the decontamination of the AIRS detectors is still under discussion and the relative contribution to the thermal parasitics should be considered TBC for the time being.

There are 5 fully redundant thermistors on each VGroove. The relative cryo harness is coupled only to the first VG1 stage. Then the cables of the remaining 10 reach VG2 and VG3 without other heat sinking stages.

The present distribution of the thermistors/heaters, and relative wires, is summarized in the following tables together with the number and size of wires reaching each thermal stage.

**Table 12. Summary of PLM thermal control thermistors, wires and heatsinking stages**

Thermistor set	No of units	No of wires	Material / AWG	VG1	VG2	VG3	TOB
TCU (excluded VGrooves)	22N + 22R	180	Ph-CuSn AWG32	X	X	X	X
TCU VGrooves VG1	15N + 15R	120	Ph-CuSn AWG32	X			
TCU VGrooves VG2	10N + 10R	80	Ph-CuSn AWG32		X		
TCU VGrooves VG3	5N + 5R	40	Ph-CuSn AWG32			X	
Decontamination	21	84	Ph-CuSn AWG32	X	X	X	X
Survival	3N + 3R	24	Ph-CuSn AWG32	X	X	X	X

	ARIEL Payload Consortium	PLM Harness Thermal Analysis	Doc Ref: ARIEL-INAF-PL-TN-005
			Issue: 4.0
			Date: 14 September 2022

**Table 13. Summary of PLM thermal control heaters, wires and heatsinking stages**

Heater set	No of units	No of wires	Material / AWG	VG1	VG2	VG3	TOB
Decontamination	7N + 7R	28	CuZn AWG28	X	X	X	X
Survival	1N + 1R	4	CuZn AWG28	X	X	X	X

### 3.1.3.1 TCU thermistors

The thermal analysis of the TCU thermistors harness is carried out in two steps. First the heat leaks of the 22 thermistors that go from the PIP connector bracket to the TOB brackets are evaluated, then the leaks of the remaining 15 thermistors for VGS monitoring. The wires of all VG 15 thermistors reach the VG1 stage, then only the wires of ten reach the VG2 stage and finally the wires of the last 5 thermometers reach the VG3.

The total heat leaks are then added together and reported in the total loads Table 21.

#### TCU thermistors without VGS

**Table 14. TCU thermistors (excluded the VGroove ones) heat leaks**

No of units	No of wires	Wire material	293-165 [W]	165-110 [W]	110-65 [W]	65-60 [W]
22 TSQ	110	PCuSn	0,11250	0,04028	0,02653	0,00235
		<b>Total wires</b>	0,11250	0,04028	0,02653	0,00235
22	250	SS braid shielding	0,12366	0,04178	0,02655	0,00230
4	1850	SS braid Overshield	0,1664	0,0562	0,0357	0,0031
		<b>Total load</b>	0,40254	0,13826	0,08879	0,00774
		<b>Total load x2 (N+R)</b>	0,80508	0,27652	0,17758	0,01547
		<b>Total load with 30% margin</b>	1,04660	0,35948	0,23085	0,02011

#### 3.1.3.1.1 VGrooves thermistors

##### VGrooves thermistors/wires distribution across stages

**Table 15. VGrooves thermistors/wires distribution**

VG thermistors	VG1	VG2	VG3
No of thermistors lines reaching the stage	15	10	5
No of wires	75	50	25
No of SS shield	15	10	5
No of Overshield	1	1	1

##### VGrooves thermistor heat leaks

**Table 16. VG thermistors heat leaks**

No of units	No of wires	Wire material	293-165 [W]	165-110 [W]	110-65 [W]
15 TSQ	75	PCuSn	0,07670	-	-
10 TSQ	50	PCuSn	-	0,01831	-
5 TSQ	25	PCuSn	-	-	0,00067
		<b>Total wires</b>	0,07670	0,01831	0,00067
15/10/5	250	SS braid shielding	0,08267	0,01862	0,00592
1	1850	SS braid Overshield	0,06313	0,02133	0,01355

	ARIEL Payload Consortium	PLM Harness Thermal Analysis	Doc Ref: ARIEL-INAF-PL-TN-005
			Issue: 4.0
			Date: 14 September 2022

		<b>Total load</b>	0,22251	0,05826	0,02014
		<b>Total load x2 (N+R)</b>	0,44502	0,11651	0,04028
		<b>Total load with 30% margin</b>	0,66753	0,17477	0,06041

### 3.1.3.2 Decontamination lines (heaters + thermistors)

Baseline: 7 heaters fully redundant, 21 thermistors cross-strapped

*Table 17. Decontamination thermistors heat leaks*

No of units	No of wires	Wire material	293-165 [W]	165-110 [W]	110-65 [W]	65-60 [W]	65-32 [W] (TBC) <sup>1</sup>
7N + 7R TSP	28	CuZn	0,1984	0,0644	0,0374	0,0029	0,1984
21	90	PCuSn	0,0920	0,0330	0,0217	0,0019	0,0920
		<b>Total wires</b>	0,2904	0,0974	0,0591	0,0049	0,2904
21	250	SS braid shielding	0,1180	0,0399	0,0253	0,0022	0,1180
2	1850	SS braid Overshield	0,0832	0,0281	0,0179	0,0015	0,0832
		<b>Total load</b>	0,4916	0,1654	0,1023	0,0086	0,4916
		<b>Total load with 30% margin</b>	0,6391	0,2150	0,1330	0,0112	0,6391

Note: <sup>1</sup> the decontamination line on the ACS cold tip is not confirmed at this stage.

### 3.1.3.3 Survival lines

Baseline: 1 heater, 3 fully redundant thermistors

*Table 18. Survival thermistors heat leaks*

No of units	No of wires	Wire material	293-165 [W]	165-110 [W]	110-65 [W]	65-60 [W]
2 TSP	4	CuZn	0,0283	0,0092	0,0053	0,0004
3 TSQ	15	PCuSn	0,0153	0,0055	0,0036	0,0003
		<b>Total wires</b>	0,0437	0,0147	0,0090	0,0007
3	250	SS braid shielding	0,1012	0,0342	0,0217	0,0019
1	1850	SS braid Overshield	0,0416	0,0141	0,0089	0,0008
		<b>Total load</b>	0,1865	0,0629	0,0396	0,0034
		<b>Total load x2 (N+R)</b>	0,3729	0,1259	0,0792	0,0068
		<b>Total load with 30% margin</b>	0,4848	0,1636	0,1030	0,0088

The assumption that the decontamination and survival heater wires are made of CuZn AWG28 is conservative. On the one hand, the use of brass allows to minimise Joule heating effects along the cables that could inject parasitic leaks across the PLM. On the other hand, it should be noted that the activation of the decontamination/survival lines is planned only during Contingency or Off-Normal operating modes, when the PLM thermal balance full performances are not required. This consideration may lead to a revision of the thermal design of the decontamination and survival lines cables, assuming less conductive materials (Manganine or Stainless Steel, e.g.) and smaller gauges.

	ARIEL Payload Consortium	PLM Harness Thermal Analysis	Doc Ref: ARIEL-INAF-PL-TN-005 Issue: 4.0 Date: 14 September 2022
--	-----------------------------	---------------------------------	--

### 3.2 GROUNDING LINES

The grounding lines represent another contributor to the total harness heat leaks, as they have to connect all stages with very low total electrical resistance wires. The electrical specifications are still under definition and the evaluation of their thermal leaks is based on the following approach:

- total electrical  $R < 10\text{-}20$  mOhm (TBC, in line with the ECSS indications)
- parallel of 5 Cu AWG28 wires

The corresponding estimated heat leak on stages is as follows.

*Table 19. Ground lines heat leaks*

No of wires	Wire material	293-165 [W]	165-110 [W]	110-65 [W]	65-60 [W]
5	Cu	0,1356	0,0607	0,0620	0,0090
	<b>Total load</b>	0,1356	0,0607	0,0620	0,0090
	<b>Total load with 30% margin</b>	0,1763	0,1086	0,0995	0,0133

The assumptions of this analysis shall be reviewed in the next design phase of the project.

### 3.3 M2M CRYO HARNESS

The M2 mechanism cryo harness is described in [RD6]. The baseline assumption is that the cables will run directly from the PIP connector bracket to the telescope optical bench. To minimize the parasitic leaks on the thermal stages the cables include a thermal break section in stainless steel, for a total length of 0.6 m that cuts most of the conducted load down. In [RD6] is shown how the present configuration can limit the heat leak to the TOB at the level of few mW ( $< 6$ ).

The assumptions are:

- 11 stainless steel wires AWG28
- thermal break length approximately 0.6 m
- no shielding required

The residual heat leak on the TOB stage is:

*Table 20. M2M cryoharness heat leaks*

No of cables	No of wires	Wire material	293-165 [W]	165-110 [W]	110-65 [W]	65-60 [W]
1 TSQ	4	SS	0,0000	0,0000	0,0000	0,0008
6 TSP	12	SS	0,0000	0,0000	0,0000	0,0023
		<b>Total load</b>	0,0000	0,0000	0,0000	0,0008
		<b>Total load x2 (N+R)</b>	0,0000	0,0000	0,0000	0,0016
		<b>Total load with 30% margin</b>	0,0000	0,0000	0,0000	0,0020

	ARIEL Payload Consortium	PLM Harness Thermal Analysis	Doc Ref: ARIEL-INAF-PL-TN-005
			Issue: 4.0
			Date: 14 September 2022

## 4 TOTAL CRYO HARNESS HEAT FLUXES

The summary of the overall heat leaks on the PLM thermal stages due to the different cryoharness branches is reported in the following table:

**Table 21. Ariel PLM total heat leaks on the thermal stages**

Harness Bundle		VG1 [mW]	VG2 [mW]	VG3 [mW]	OB [mW]	Cold tip [mW]	CFEE Stage [mW]		
<b>Detectors control</b>									
AIRS CU	AIRS	AIRS CFEE bias/output		456	179	152	19	NA	NA
	CFEE	AIRS CFEE clock		269	93	60	5	NA	NA
	AIRS Thermal Control		499	174	112	10	NA	NA	
FGS FOM/FPE	FGS Sidecar	FGS CFEE Ctrl/Output		1069	0	0	0	NA	32
		FGS FPE TC		246	0	0	0	NA	6
	FOM Thermal Control		303	103	66	6	NA	NA	
THERMAL CONTROL	TCU Thermal control		1179	371	208	15	NA	NA	
	M2 control		0	0	0	2	NA	NA	
	ACS		0	0	0	0	0	NA	
	Grounding wires		136	84	77	10	NA	NA	
	Decontamination		487	164	101	9	6	NA	
	Survival		400	135	85	7	NA	NA	
<b>Total load on stage</b>			<b>5044</b>	<b>1302</b>	<b>861</b>	<b>82</b>	<b>6</b>	<b>38</b>	
<b>Total load on stage (30% margin)</b>			<b>6558</b>	<b>1693</b>	<b>1119</b>	<b>107</b>	<b>7</b>	<b>NA</b>	

**Notes:**

- It is assumed that the cryo-harness heat leaks are intercepted on each thermal stage before reaching the colder following one with the exception of the FGS detectors control cables (from the FCU to the Sidecar) that run directly from VG1 to the Sidecar to help maintaining the electronics above 135K passively with an extra heat leak.  
Main assumptions used for the calculation:
  - the thermal breaks between stages are at least 15 cm long (if this reduces, loads increase);
  - heater and control/power lines use brass (CuZn) wires with AWG28;
  - reading, sensing and thermistors lines use PCuSn (Phosphor Bronze) AWG32;
  - all shielding is made of stainless steel;
  - all thermistors are read by a 4-wire twisted quad configuration (shielded);
  - the PLM decontamination heaters have a 2-wire twisted pair configuration (shielded) ;
  - 37 thermistors (plus Red) are controlled by the TCU for a total of 300 wires plus shielding;
  - M2M control uses stainless steel wires, cables go directly from SVM connector bracket to the TOB;
  - ACS harness leaks are assumed to be dissipated along the pipework. Only decontamination cable parasitics are assumed from the TOB to the cold tip.
- Detectors control harness is assumed to be split in readout/control cable, clock and thermal control cables.
- Includes all thermistors controlled by the TCU and not the ones that are part of the instrument detectors thermal control.

In the present issue of the Ariel PLM TMM, the contribution of the harness is evaluated by using dedicated conductors with an associated thermal conductance that can mimic and inject on the stages the resulting heat leaks reported in Table 21, across the same temperature ranges, with a margin of approximately 10%. This assumption is based on the fact that in the analysis:

	ARIEL Payload Consortium	PLM Harness Thermal Analysis	Doc Ref: ARIEL-INAF-PL-TN-005 Issue: 4.0 Date: 14 September 2022
--	-----------------------------	---------------------------------	--

1. the heat leaks are calculated using always the maximum temperature difference between the stages, leading to an overestimated G;
2. some worst-case guesses have already been made on wires gauge, material properties and shielding dimensions. For example, the conductance of the final section of the cables, that runs from VG3 to the side of the TOB, is computed assuming the same thermal length (i.e. 15 cm) of the other thermal breaks, even if it is almost certain that the harness CAD routing will require a longer cable length.

Table 21 shows that the total loads due to the cryoharness has become one of the major contributors to the parasitic leaks to the stages. The GTMM analyses demonstrate there is a significant impact on the steady-state temperature of the cold PLM sub-systems. If the total loads presented in the table are compared to the results of the analyses performed in the past, it can be noticed that the leaks estimation has been constantly increasing with the PLM and harness design evolution. There is an increase in the loads on the stages approximately by a factor of 4 and 1.5 with respect to the pSRR and IICC results, respectively. This is mainly due to several concurring factors:

- the reduction of the cables thermal breaks length (from 30 cm to 15 cm, a factor of 2);
- the more advanced design and specs of the detectors cryoharness;
- the need for several low electrical resistance lines (i.e. Copper wires) for detectors control/readout;
- the increase in the assumptions on the number and dimensions of the cables/bundles' shielding;
- the assumption of Ph-CuSn wires for the decontamination and survival lines instead of lower conductivity materials (Manganine or Stainless Steel) to simplify the cables manufacturing and avoid possible issues with the heritage of potential providers;
- the need for low electrical resistance grounding wires (Cu AWG 28) across all stages.

In the next phase of the PLM design, every effort should be made, in collaboration with the harness manufacturers, to optimize the thermal design. All the assumptions of the present analysis shall be reviewed, and, possibly, optimized to reduce the parasitic loads, on VG3 and the TOB especially.

	ARIEL Payload Consortium	PLM Harness Thermal Analysis	Doc Ref: ARIEL-INAF-PL-TN-005 Issue: 4.0 Date: 14 September 2022
--	-----------------------------	---------------------------------	--

## 5 ACKNOWLEDGMENTS

We acknowledge the financial contribution by the Italian Space Agency to the Ariel project in the framework of the ASI-INAF agreement 2021-05-HH.0.