



<b>Publication Year</b>	2022
<b>Acceptance in OA</b>	2023-02-27T11:28:06Z
<b>Title</b>	X-IFU Filter Wheel Optical Blocking Filters Technology Demonstration Plan
<b>Authors</b>	BARBERA, Marco, BOZZO , ENRICO, D'ANCA, FABIO, LO CICERO, UGO, MONTINARO, NICOLA, SCIORTINO, LUISA, TODARO, Michela
<b>Handle</b>	<a href="http://hdl.handle.net/20.500.12386/33913">http://hdl.handle.net/20.500.12386/33913</a>
<b>Volume</b>	XIFU-TN-UoG-0002

	<h2>X-IFU FW Filters Technology Demonstration Plan</h2>	<p><b>DOC.: XIFU-TN-UoG-0002</b>  <b>ISSUE: 1</b>  <b>DATE: 10/05/2022</b>  <b>PAGE: 1 of 30</b></p>
---	---	--

<b>Title</b>	<b>X-IFU Filter Wheel Optical Blocking Filters Technology Demonstration Plan</b>	
Prepared by :	M. Barbera, E. Bozzo, F. D’Anca, U. Lo Cicero, N. Montinaro, L. Sciortino, M. Todaro	Date: 10/05/2022
Inputs by:		Date:
Checked by:	E. Bozzo	Date: 12/05/2022
Approved by:	E. Bozzo	Date: 12/05/2022
Authorised by:	S. Paltani	Date: 12/05/2022

	<h2>X-IFU FW Filters Technology Demonstration Plan</h2>	<p><b>DOC:</b> XIFU-TN-UoG-0002  <b>ISSUE:</b> 1  <b>DATE:</b> 10/05/2022  <b>PAGE:</b> 2 of 30</p>
---	---	---

### DISTRIBUTION LIST

X-IFU consortium  
 ESA

### DOCUMENT CHANGE RECORD

Issue	Date	Changed Section	Description of Change
Draft	29/03/2022		Internal document
Issue 1	10/05/2022	All	Major revision, first issue

### Abbreviations and acronyms

Item	Meaning
BB	BreadBoard
BeCu	Beryllium Copper
BF	Blocking Factor
FD	Fast detector
FW	Filter Wheel
FWA	Filter Wheel Assembly
I-PRR	Instrument - Preliminary Requirements Review
INAF	Istituto Nazionale di Astrofisica
LDA	Large detector array
MAR	Mission Adoption Review
RoD	Review of Design
SS	Stainless steel

	<h2>X-IFU FW Filters Technology Demonstration Plan</h2>	<p><b>DOC: XIFU-TN-UoG-0002</b>  <b>ISSUE: 1</b>  <b>DATE: 10/05/2022</b>  <b>PAGE: 3 of 30</b></p>
---	---	---

TBC	To be confirmed
TBD	To be defined
THF	Thermal Filters
TRL	Technology Readiness Level
UniGE	University of Genève
UniPA	University of Palermo
WFI	Wide Field Imager
X-IFU	X-ray Integral Field Unit

### Applicable Documents

[AD#]	Doc. Reference	Issue	Title
[AD1]	XIFU-PL-MAN-296-CNES	3	X-IFU Critical Items Demonstration Plan Description. Design and interface reqs.

### Reference Documents

[RD#]	Doc. Reference	Issue	Title
[RD1]	XIFU-TN-UoG-0001	0.1	X-IFU Filter Wheel Mechanism and Electronics Design Description
[RD2]	XIFU-UNPA-THF-TN-0001	1	Thermal Filters for the ATHENA X-IFU: Conceptual Design, Performance Modelling and Preliminary Characterization Tests. (I-PRR THF Description Document)
[RD3]	XIFU-RD-14000-265-CNES		XIFU Filter Wheel Requirement Document
[RD4]	Proc. SPIE 9905, 990566 (2016). doi: 10.1117/12.2232376		Surface investigation and aluminum oxide estimation on test filters for the ATHENA X-IFU and WFI detectors
[RD5]	JLTP 193, 793–798 (2018). doi: 10.1007/s10909-018-1942-z		Preliminary Mechanical Characterization of Thermal Filters for the X-IFU Instrument on Athena



**UNIVERSITÉ  
DE GENÈVE**  
FACULTÉ DES SCIENCES



**INAF**  
ISTITUTO NAZIONALE  
DI ASTRONOMIA



## X-IFU FW Filters Technology Demonstration Plan

**DOC: XIFU-TN-UoG-0002**

**ISSUE: 1**

**DATE: 10/05/2022**

**PAGE: 4 of 30**

[RD6]	Proc. SPIE 10699, 106991K (2018); doi: 10.1117/12.2314448	ATHENA WFI optical blocking filters development status toward the end of the instrument phase-A
[RD7]	Proc. SPIE 10699, 106991R (2018); doi: 10.1117/12.2314450	ATHENA X-IFU thermal filters development status toward the end of the instrument phase-A
[RD8]	XIFU-UNPA-DRW-912110-003-01-00 3_FW_Thin_OBF_BB_Mesh	Mechanical design structural mesh of FW OBF breadboard (14/11/2021)
[RD9]	[RD9]_XIFU-UNPA-DRW-912110-003 -01-004_FW_Thin_OBF_BB_Mesh	Mechanical design structural mesh of FW OBF breadboard (14/11/2021)
[RD10]	XIFU-UNPA-DRW-912110-001-01-00 1_FW_Thin_OBF_BB_Outer_Frame	Outer frame of the BB with cD160mm

 <b>UNIVERSITÉ DE GENÈVE</b> FACULTÉ DES SCIENCES		<h1>X-IFU FW Filters Technology Demonstration Plan</h1>	<b>DOC: XIFU-TN-UoG-0002</b>
			<b>ISSUE: 1</b>
			<b>DATE: 10/05/2022</b>
			<b>PAGE: 5 of 30</b>

## Table Of Contents

<b>1</b>	<b>INTRODUCTION</b>	<b>5</b>
1.1	<b>Objectives of the technology demonstration plan</b>	<b>5</b>
<b>2</b>	<b>FILTER WHEEL FILTERS OVERVIEW</b>	<b>7</b>
<b>3</b>	<b>FW FILTERS CONCEPT VALIDATION</b>	<b>11</b>
<b>4</b>	<b>TECHNOLOGY VS DESIGN</b>	<b>13</b>
<b>5</b>	<b>FW FILTER MODEL PHILOSOPHY</b>	<b>13</b>
5.1	<b>Expected Models</b>	<b>13</b>
<b>6</b>	<b>LIST OF TECHNOLOGICAL PROCESSES</b>	<b>13</b>
<b>7</b>	<b>VALIDATION OF CRITICAL TECHNOLOGIES TO GET THE TRL5</b>	<b>14</b>
7.1	<b>T1 - Full size scale thin polyimide foil</b>	<b>15</b>
7.2	<b>T2 - Full size scale Al coating</b>	<b>15</b>
7.3	<b>T3 - Full size scale mesh with 4% blocking factor</b>	<b>16</b>
7.4	<b>T4 - Full size scale uniform and defect free bonding between plastic film and mesh</b>	<b>16</b>
<b>8</b>	<b>LIST OF BBs TO BE PROCURED AND TEST CHARACTERIZATION OF EACH TECHNOLOGY</b>	<b>17</b>
<b>9</b>	<b>RISK MITIGATION</b>	<b>21</b>
<b>10</b>	<b>PLANNING</b>	<b>22</b>
<b>11</b>	<b>FACILITIES DESCRIPTION</b>	<b>23</b>
11.1	<b>Visual Inspection</b>	<b>23</b>
11.2	<b>Surface Analysis</b>	<b>23</b>
11.3	<b>X-ray Absorption spectroscopy</b>	<b>24</b>
11.4	<b>UV/VIS/NIR Transmission</b>	<b>25</b>
11.5	<b>Static differential Pressure</b>	<b>26</b>
11.6	<b>Vibrational Tests</b>	<b>26</b>

	<h1>X-IFU FW Filters Technology Demonstration Plan</h1>	<p>DOC: XIFU-TN-UoG-0002  ISSUE: 1  DATE: 10/05/2022  PAGE: 6 of 30</p>
---	---	---

## 1 Introduction

### 1.1 Objectives of the technology demonstration plan

The main purpose of the present plan is to provide a clear path to demonstrate the TRL5 by the Mission Adoption for the three OBFs on the X-IFU Filter Wheel (FW).

The reference statement from which we have derived our present Technology Demonstration Plan comes from the “X-IFU Critical Items Demonstration Plan” document [AD1] where it is reported:

*“The Technology should not be developed to the detriment of the Design. The confusion between Technology demonstration and Design has for consequence to go into Technology demonstration by sacrificing the design with negative impacts:*

- *Poor requirements*
- *Poor level of trade-offs*
- *Poor understanding of design drivers”*

Hence, an effort has been performed in trying to identify what shall be considered technology, for which the maturity has to be demonstrated, and what is design that can still contribute to improve the performances of the FW filters along phases B and C of development.

The X-IFU FW filters conceptual design is similar to that defined (during phase A) and described in the “X-IFU Filter Wheel Mechanism and Electronics Design Description” [RD1] and the “X-IFU Thermal Filters (THFs) Description” [RD2] documents presented at the I-PRR. The preliminary design of the X-IFU FW Filters rely on heritage from previous missions and characterization tests performed in phase-A on breadboards manufactured by LUXEL Corporation (Friday Harbor, WA, USA).

The adoption of a design similar to that of the X-IFU THFs for frame shape and materials, and to that of the WFI FW filters for film and coating thicknesses, as well as for overall dimensions, allow migrating part of the achievements reached by the X-IFU THFs and WFI FW filters to the X-IFU FW filters.

For this reason, the TDP for the X-IFU FW filters will be mainly focused on the vibro-acoustic performances. With this respect, minor effort will be dedicated to the thick and very robust meshless filter (25  $\mu\text{m}$  PI + 100 nm Al) designed to observe very bright x-ray sources.

The goal of this activity is to demonstrate TRL5 before MAR for the baseline technology of filters manufactured by LUXEL (PI/Al on BeCu mesh). However, in parallel to verify also the maturity of other filter technologies and to mitigate the risks of having only one manufacturer, we will procure and test filter samples and bare meshes of other European manufacturers (OXFORD instruments, XRNanotech).

The identified **TECHNOLOGY** development elements that we consider critical in the X-IFU FW OBFs are described below. In section 7 we list the breadboards (BBs) we have identified to perform the necessary characterization tests aimed at demonstrating their maturity.

 <p>UNIVERSITÉ DE GENÈVE FACULTÉ DES SCIENCES</p> <p>INAF ISTITUTO NAZIONALE DI ASTRONOMIA E FISICA SPAZIALE</p> <p>IFU</p>	<h2>X-IFU FW Filters Technology Demonstration Plan</h2>	<p>DOC: XIFU-TN-UoG-0002</p> <p>ISSUE: 1</p> <p>DATE: 10/05/2022</p> <p>PAGE: 7 of 30</p>
--	---	---

1. **T1 - Full size scale mesh with ~4% blocking factor** with pitch size ~ 5 mm to guarantee mechanical robustness of the thin membrane inside the mesh cells.
2. **T2 Full size scale thin polyimide foil** with ~ 150 nm uniform thickness, defects free and with acceptable number of pinholes (pinhole area/filter area <  $10^{-5}$ , TBC).
3. **T3 - Full size scale thin Al coating** with ~ 30 nm / 70 nm uniform thickness, defects free and with acceptable number of pinholes (pinhole area/filter area <  $10^{-5}$ , TBC).
4. **T4 - Full size scale uniform and defect free bonding between plastic film and mesh.**

The identified **DESIGN** optimization elements are:

1. Frame mechanical optimization
2. Mesh mechanical optimization
3. Film thickness optimization

TRL5 of the identified technologies shall be demonstrated by also proving compliance to the requirements or by identifying a design improvement that can allow to meet the requirements with the adopted technology. Moreover, similar OBFs (both thin and thick) have passed the acoustic and vibration tests on the WFI. Despite the environment conditions being different, the WFI results represent a good heritage. Plans to raise TRL of X-IFU OBFs by Mission Adoption will also benefit from the ongoing activities in place at UniPA to increase the TRL of the X-IFU THFs.

The document is structured as follows:

- § 1 - brief overview of the X-IFU FW OBFs conceptual design
- § 2 - brief report on the X-IFU FW OBFs concept validation
- § 3 - technology vs design
- § 4 - FW OBFs model philosophy
- § 5 - list of the technological processes needed to manufacture the FW Filters
- § 6 - validation of the critical technologies to get TRL5
- § 7 - list of BBs to be procured
- § 8 - BBs procurement and characterization tests planning
- § 9 - Risk mitigation
- § 10 - Planning
- § 11 - Description of the experimental facilities used for technology validation

 <p>UNIVERSITÉ DE GENÈVE FACULTÉ DES SCIENCES</p> <p>INAF ISTITUTO NAZIONALE DI ASTRONOMIA E FISICA SPAZIALE</p> <p>IFU</p>	<h2>X-IFU FW Filters Technology Demonstration Plan</h2>	<p>DOC: XIFU-TN-UoG-0002</p> <p>ISSUE: 1</p> <p>DATE: 10/05/2022</p> <p>PAGE: 8 of 30</p>
--	---	---

## 2 Filter Wheel Filters Overview

According to the requirements and based on heritage from previous space missions using microcalorimeter detectors, and on the results of preliminary characterization tests performed on partially representative breadboards, we have identified as the current baseline a set of four filters, consisting of:

- Two optical blocking filters (OBF) needed to limit the optical load from the bright UV/Vis counterparts of the X-ray sources to be observed by the X-IFU.  
The first OBF called herein after “Thin OBF” will consist of a 150 nm thick Polyimide film coated with 30 nm of Aluminum and supported by a BeCu alloy gold plated mesh.  
The second OBF called herein after “Thick OBF” will consist of a 150 nm thick Polyimide film coated with 70 nm of Aluminum and supported by a BeCu alloy gold plated mesh.
- Two X-ray blocking Filters (XBF) to suppress the X-ray fluxes of celestial sources at energies  $< 3$  keV, where the bulk of the X-ray photons are usually emitted. These filters are needed to limit the degradation of the X-IFU performances during the observations of particularly soft and bright X-ray sources.  
The first XBF called herein after “Thin XBF” consists of a 25  $\mu\text{m}$  thick polyimide film coated with 50 nm of Aluminum on both faces.  
The second XBF called herein after “Thick XBF” is yet TBD, though, it will likely also consist of a thick polyimide foil coated with aluminum.

Due to the higher thickness of the “Thick XBF” film, no reinforcing mesh is needed. This technology is replacing the old baseline consisting of a 100  $\mu\text{m}$  thick Beryllium filter.

The four filters will be mounted on the FW in the position indicated in Figure 1. In the current FW design the OBFs have clear aperture diameters of  $\sim 160$  mm. Table 1 reports the main design parameters of the baseline FW filters. The technologies will be demonstrated with test campaigns on filter breadboards with reference to these sets of parameters.

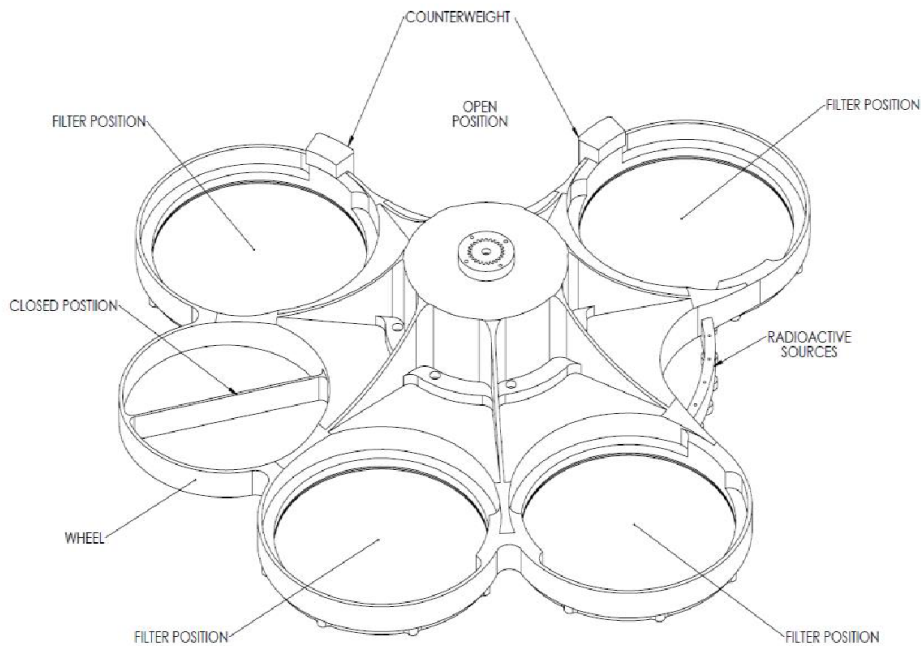

**Fig. 1.** Filter Wheel current design with its seven filter positions; four of them are for the OBFs (with one of them as spare).

**Table 1.** Main characteristics of the investigated set of FW filters. Z is the distance from the focal plane. BF is the blocking factor, i.e. the fraction of area covered by the mesh. I.D. is the frame inner diameter corresponding to the filter clear aperture.

Name	Z [mm]	I.D. [mm]	Material	MESH SPECS				Membrane Thickness [μm]	Coating Thickness [nm]
				Pitch[mm]	Thick [μm]	Bar width [μm]	BF [%]		
<b>Thin OBFs</b>	620	160	BeCu/Au	4.85 or 5.10	150	75 or 85	~ 4	0.150	30
<b>Thick OBFs</b>	620	160	BeCu/Au	4.85 or 5.10	150	75 or 85	~ 4	0.150	70
<b>Thick XBF</b>	620	160	No Mesh, self standing membrane				25	50/50 (both sides)	
<b>Thick XBF</b>	620	160	No Mesh, self standing membrane				TBD	TBD	

In Figure 2 the filter mounting scheme for the Thin and Thick OBFs (left) and for the self standing Thin and Thick XBF (right) are shown.

The Thin and Thick OBFs are composed of: 1) outer frame, 2) inner frame, 3) reinforcing mesh and 4) aluminum coated polyimide membrane.

As shown on Figure 2 the XBFs don't need the reinforcing mesh thus are composed of only three parts: 1) outer frame, 2) inner frame and 3) aluminum coated polyimide membrane. In both types of filters the parts are all glued together with epoxy.

In particular, the Thin and Thick OBFs have the following gluing sequence:

- I. Mesh to inner frame glued with a structural epoxy filled with silver particles in some point to ensure conductivity;
- II. Membrane to reinforcing mesh;
- III. the above parts (II) to the outer frame (glued with the above mentioned structural epoxy).

The gluing sequence for the XBFs, without the reinforcing mesh consists only of the two following steps:

- I. Foil to inner frame glued with a structural epoxy;
- II. the above parts (I) to the outer frame (glued with the above mentioned structural epoxy filled with silver particles in some point to ensure conductivity);

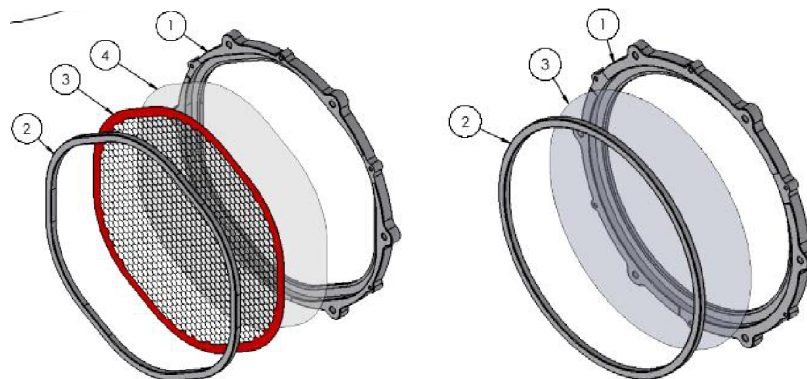

**Fig. 2.** Schematic mounting of the X-IFU FW Thin and Thick OBFs (on the left) and the self-standing Thin and Thick XBFs (on the right).

As already mentioned, the similarities between the X-IFU THFs with the X-IFU FW OBFs (for chosen materials) and with the WFI filter (for film thickness and overall dimensions), combined with the less stringent requirements of the X-IFU FW filters with respect to X-ray transparency, allows migrating some of the achievements reached by the X-IFU THFs and WFI OBFs.

In order to support the design consolidation and increase the TRL of the proposed technology, different test samples have been procured/manufactured along the phase-A for the X-IFU THFs and WFI OBFs.

The procured X-IFU THFs breadboards can be divided into three main sets:

 <b>UNIVERSITÉ DE GENÈVE</b> FACULTÉ DES SCIENCES		<h2>X-IFU FW Filters Technology Demonstration Plan</h2>	<b>DOC: XIFU-TN-UoG-0002</b>
 <b>INAF</b> ISTITUTO NAZIONALE DI ASTRONOMIA			<b>ISSUE: 1</b>
			<b>DATE: 10/05/2022</b>
			<b>PAGE: 11 of 30</b>

1) small size witness samples for optical properties characterization and surface analysis mounted on standard TF110/TF111 LUXEL frames with 10/17 mm inner diameter;

2) large size samples with stainless steel (SS) meshes with representative geometrical BF and pitch size and metal-coated thick polypropylene films replacing the thin polyimide to test the mechanical properties of the meshes;

3) medium size samples with representative gold plated SS meshes with a BF of ~4% (with BF including the plating) and thin polyimide 45 nm thick films coated with 30 nm of aluminum. These samples are used for mechanical and environmental tests of the thin membrane mounted on meshes. Figure 3 shows pictures of two large size samples (top row) and two medium size samples (bottom row).

**I.D.=100 mm, Polypropylene/Ti,  
SS coarse mesh**

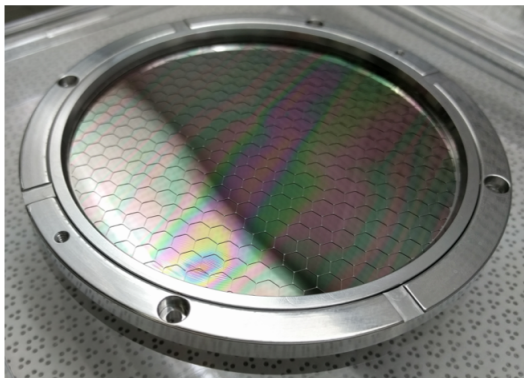

**I.D.= 56 mm, Polypropylene/Ti,  
SS fine mesh**

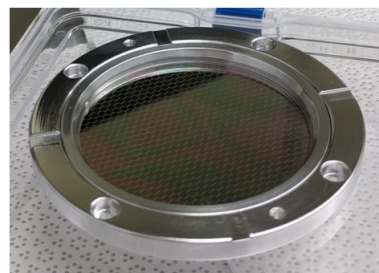

**I.D. = 30 mm, Polyimide/Al,  
Au plated SS coarse mesh**

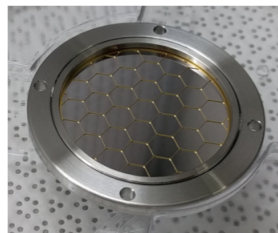

**I.D. = 30 mm, Polyimide/Al,  
Au plated SS fine mesh**

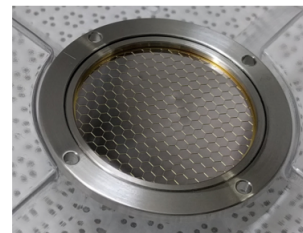

**Fig. 3.** Pictures of two large size samples (top row) and two medium size samples (bottom row).

The procured WFI breadboards, manufactured by LUXEL, to consolidate the design and increase the TRL are:

- one WFI Large Detector Array (LDA) OBF (polyimide film 150 nm coated with 30 nm of aluminum and supported by a Au plated SS mesh); (see Figure 4 on the left panel).
- one WFI LDA OBF (polyimide film 200 nm coated with 30 nm of aluminum and supported by a Au plated SS mesh);
- one WFI Fast Detector (FD) OBF (polyimide film 150 nm coated with 30 nm of aluminum and supported by a Au plated SS mesh);

 <p>UNIVERSITÉ DE GENÈVE FACULTÉ DES SCIENCES</p> <p>INAF ISTITUTO NAZIONALE DI ASTRONOMIA E FISICA SPAZIALE</p> <p>IFU</p>	<h2>X-IFU FW Filters Technology Demonstration Plan</h2>	<p>DOC: XIFU-TN-UoG-0002</p> <p>ISSUE: 1</p> <p>DATE: 10/05/2022</p> <p>PAGE: 12 of 30</p>
--	---	--

- one WFI FD OBF (polyimide film 200 nm coated with 30 nm of aluminum and supported by a Au plated SS mesh) (see Figure 4 on the right panel).

In addition, to verify the maturity of other filter technologies and to mitigate the risks, the following filter samples were procured from another European manufacturer OXFORD instruments:

- two single quadrants of the WFI LDA OBF (polyimide 140 nm coated with 30 nm of aluminum and supported by a polyimide mesh); (see Figure 5);
- medium size circular filters with ~50 mm of clear aperture diameter made out of polyimide film supported by a polyimide mesh;
- One full size X-IFU OBF polyimide film of 140 nm coated with 30 nm of aluminum and supported by a polyimide mesh mounted on a X-IFU OBF frame with 160 mm clear aperture diameter (see Figure 6).

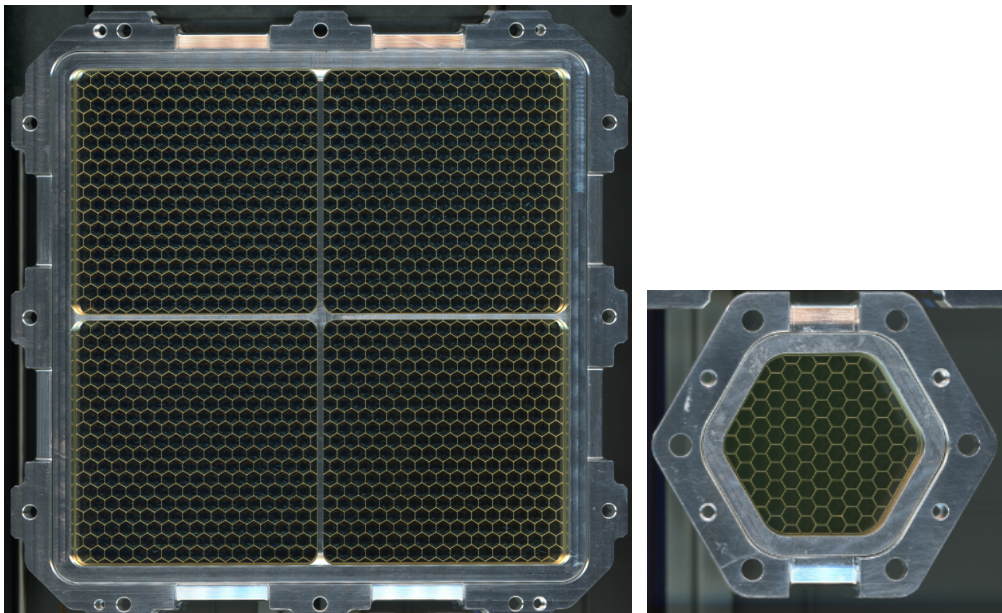

**Fig. 4.** Picture of a WFI LDA full-size filter with 150 nm thick polyimide film coated with 30 nm of aluminum reinforced by metallic mesh (on left) and Fast Detector made out of 150 nm thick polyimide film reinforced by metallic mesh (on right), both filters are manufactured by LUXEL.

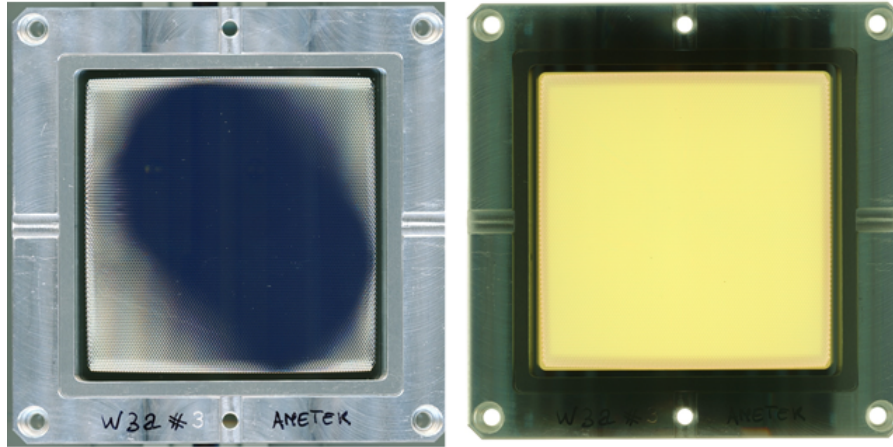

**Fig. 5.** Scan in reflection and transmission of a WFI LDA single quadrant filter with 140 nm thick polyimide film coated with 30 nm of aluminum reinforced by a polyimide mesh manufactured by OXFORD Instruments.

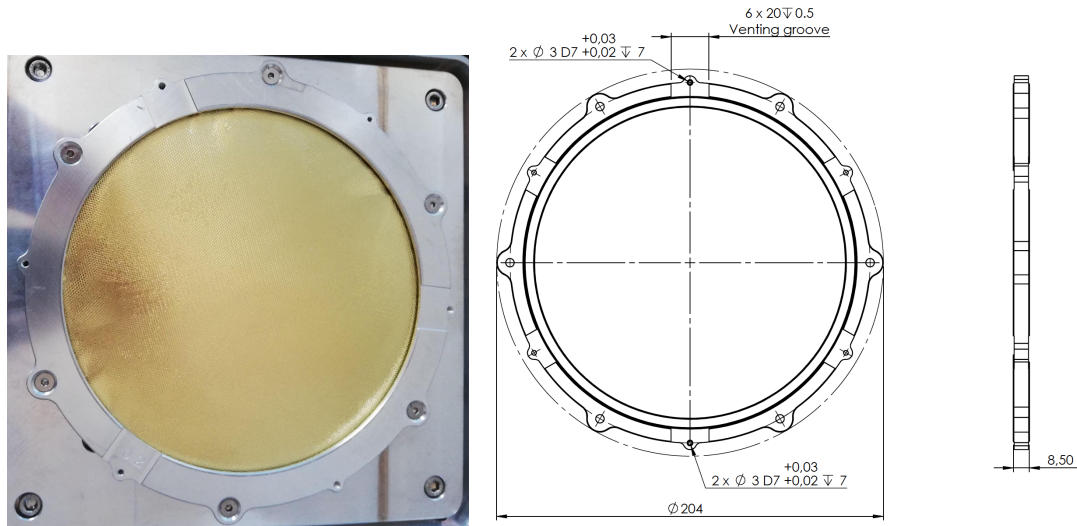

**Fig. 6.** Picture (on the left) and drawing (on the right) of a X-IFU OBF (160 mm clear aperture diameter) with 140 nm thick polyimide film coated with 30 nm of aluminum reinforced by a polyimide mesh manufactured by OXFORD Instruments.

Preliminary results of optical and mechanical characterization tests performed on THFs BBs [RD4, RD5, RD6, RD7] show that the currently investigated technology is close to TRL4.

### 3 [FW Filters concept validation](#)

	<h2>X-IFU FW Filters Technology Demonstration Plan</h2>	<p><b>DOC:</b> XIFU-TN-UoG-0002  <b>ISSUE:</b> 1  <b>DATE:</b> 10/05/2022  <b>PAGE:</b> 14 of 30</p>
---	---	--

The X-IFU FW OBFs baseline design compliance to requirements has been validated by simulations during phase A/B1. Following is a short list of the requirements to fulfill:

**Table 2** - Performance Requirements of the X-IFU FW Filters.

PERFORMANCE REQUIREMENTS		VERIFICATION METHOD
Thick XBF	The FW Thick XBF shall have a transmission: $\geq 95\%$ (TBC) above 7 keV $\leq 1.6 \times 10^{-5}$ below 1 keV	RoD/Test
Thin XBF	The FW Thin XBF shall have a transmission: $\geq$ TBD % above 3 keV $\leq$ TBD below 1 keV	RoD/Test
Thick OBF	The FW Thick OBF should have a transmission: $\geq 88\%$ (TBC) at 1 keV $\leq 10^{-6}$ (TBC) in the wavelength range: 91-2000 nm (TBC)	RoD/Test
Thin OBF	The FW Thin OBF should have a transmission: $\geq 90\%$ (TBC) at 1 keV $\leq 10^{-4}$ (TBC) in the wavelength range: 91-2000 nm (TBC)	RoD/Test

RoD = Review of Design

**Table 3** - Technical Requirements of the X-IFU FW Filters.

TECHNICAL REQUIREMENTS		VERIFICATION METHOD
Max Diff. Pressure	2 mbar (TBC)	Analysis/Test
Vibration	Sine Launch QL (TBC)	Analysis/Test
Vibration	Random Launch QL (TBC)	Analysis/Test
Vibration	Shock QL (TBD)	Analysis/Test
Acoustics	Launch QL (TBD)	Analysis/Test

#### 4 Technology VS design

Following the objectives already presented in the introduction, Table 4 shows the separation between technology and design development issues. This table represents our main reference for the TRL5 demonstration plan.

**Table 4** - Technology vs Design development issues.

Technology	Design
1 Full size scale mesh with 4% blocking factor.	1 frame mechanical optimization
2 Full size scale thin plastic foil.	2 mesh mechanical optimization
3 Full size scale thin Al coating.	
4 Uniform and defect-free bonding between plastic film and mesh.	

In order to deal with unavoidable overlap between Technology and Design, we assume to transfer the optimization process to the design, while validating the technologies on BBs not necessarily containing all the details of fully representative filters.

## 5 FW Filter model philosophy

### 5.1 Expected Models

The expected FW filter models to support the instrument development are:

1. Engineering Model (EM)
2. Structural Model (SM)
3. Qualification Model (QM)
4. Flight Model (FM)
5. Flight Spare (FS)

## 6 List of technological processes

The FW filters are manufactured according to the process flow shown in Figure 7. The processes under our responsibility are not relevant for demonstration purposes.

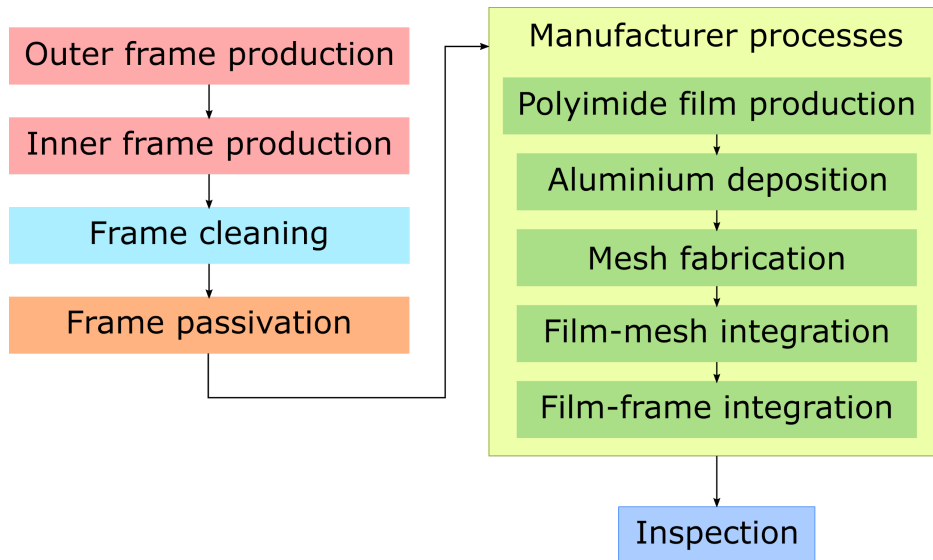

**Fig. 7** – FW filters manufacturing process flow.

Currently, the manufacturer identified for the baseline filters whose technological maturity will be demonstrated is LUXEL Corporation (Friday Harbor, WA, USA) and its processes are uniquely identified by a code specified in the filter certificate. The Declared Material and Process lists for the baseline filters are listed below:

- DML: XIFU-UNPA-THF-LI-0001-r00\_DML THF Declared Material List
- DPL: XIFU-UNPA-THF-LI-0002-i01-r00\_DPL THF Declared Process List

## 7 Validation of critical technologies to get the TRL5

In order to demonstrate TRL5 on X-IFU FW filters, representative large diameter filters (with ID equal to 160 mm) made with polyimide film (150 nm) aluminum coated (30 nm and 70 nm) supported by metallic mesh (BF ~ 4%) must be proved to: static differential pressure, acoustic load, vibration loads, and thermo-vacuum (TBC).

In parallel and as part of the risk mitigation actions, we will procure and test filter samples of other European manufacturers (OXFORD instruments).

The list of BBs to be procured for TRL5 demonstration and the planning of the characterization tests activity is reported in section 8. In the following, the four identified critical technologies are described together with the characterization tests we plan to perform on procured BBs to demonstrate their maturity. Pass/Fail criteria for the characterization tests are reported in Table 6.

### 7.1 T1 - Full size scale mesh with ~ 4% blocking factor

The meshes with a pitch size ~ 5 mm (TBD) shall guarantee mechanical support to the thin aluminized polyimide film.

 <p>UNIVERSITÉ DE GENÈVE FACULTÉ DES SCIENCES</p> <p>INAF ISTITUTO NAZIONALE DI ASTRONOMIA E FISICA SPAZIALE</p> <p>IFU</p>	<h2>X-IFU FW Filters Technology Demonstration Plan</h2>	<p>DOC: XIFU-TN-UoG-0002</p> <p>ISSUE: 1</p> <p>DATE: 10/05/2022</p> <p>PAGE: 17 of 30</p>
--	---	--

### BBs to be procured:

- A full scale BBs (aperture diameter 160 mm) with ~ 150 nm thick polyimide film coated with 30 nm thick aluminum, glued on a full scale fully representative Au plated BeCu mesh with 3.94% BF with arm thickness 150 um and arm width 75 um [RD8].
- A full scale BBs (aperture diameter 160 mm) with ~ 150 nm thick polyimide film coated with 70 nm thick aluminum, glued on a full scale fully representative Au plated BeCu mesh with 3.94% BF with arm thickness 150um and arm width 75 um [RD8].
- A full scale BBs (aperture diameter 160 mm) with ~ 150 nm thick polyimide film coated with 30 nm thick aluminum, glued on a full scale fully representative Au plated BeCu mesh with 4% BF with arm thickness 150 um and arm width 85 um [RD9].
- A full scale BBs (aperture diameter 160 mm) with ~ 150 nm thick polyimide film coated with 70 nm thick aluminum, glued on a full scale fully representative Au plated BeCu mesh with 4% BF with arm thickness 150 um and arm width 85 um [RD9].
- A full scale BBs of the BeCu Au plated mesh (aperture diameter 160 mm) with 3.94% BF with arm thickness 200 µm and arm width 75 µm provided by an European alternative manufacturer XRnanotech.
- A full scale BBs of the BeCu Au plated mesh (aperture diameter 160 mm) with 4% BF with arm thickness 250 µm and arm width 85 µm provided by an European alternative manufacturer XRnanotech.

### Characterization tests:

- Surface Analysis (opt. microscopy and SEM) on full size BBs meshes to verify BeCu mesh quality, measure the BF and investigate Au plating quality.
- Visual inspection with a high resolution photographic optical scanner and an optical microscope of full size BBs and the two meshes. Visual inspection to search for defects and irregularities and to investigate mesh uniformity over large areas.
- Thermo-vacuum between - 20 °C and 50 °C on full scale samples to verify effects of thermal differential contraction between mesh and frame as well as quality of plating adhesion. Visual inspections with a high resolution photographic optical scanner will be performed before and after each test.
- Vibration tests on the four full scale samples and the two meshes to verify the mechanical robustness and quality of plating adhesion. Visual inspections with a high resolution photographic optical scanner will be performed before and after each test.

 <p>UNIVERSITÉ DE GENÈVE FACULTÉ DES SCIENCES</p> <p>INAF ISTITUTO NAZIONALE DI ASTRONOMIA E FISICA SPAZIALE</p> <p>IFU</p>	<h2>X-IFU FW Filters Technology Demonstration Plan</h2>	<p>DOC: XIFU-TN-UoG-0002</p> <p>ISSUE: 1</p> <p>DATE: 10/05/2022</p> <p>PAGE: 18 of 30</p>
--	---	--

### 7.2 T2 - Full size scale thin polyimide foil

The polyimide foil of the OBF filters should have a thickness of  $\sim 150$  nm spatially uniform to within  $\pm 3\%$  (TBC) on spatial scales  $> 1$  cm<sup>2</sup>, and within  $\pm 10\%$  (TBC) on spatial scales  $< 1$  cm<sup>2</sup>. The technology must be validated only for the four fully representative BBs, no needs for the thicker 25  $\mu$ m Thick filter.

#### BBs to be procured:

- The same samples procured for T1 demonstrations.
- Small size meshless BBs with  $\sim 150$  nm thick polyimide film. These samples should be captured from one single PI foil of the same size as the one produced for the large size representative breadboards.

#### Characterization tests:

- Spatially resolved UV and/or X-Ray mapping of all small scale BBs procured to evaluate the spatial uniformity of the polyimide film.
- Differential pressure on at least one of each type of OBF mesh geometries up to 5 mbar (TBC) to verify that the thin polyimide film inside the mesh cells do not get damaged and do not reach plastic deformation regime. An optical profilometry of the filter shape is performed while samples are under differential pressure load. Visual inspections with a high resolution photographic optical scanner will be performed before and after each test.
- 

### 7.3 T3 - Full size scale Al coating

The aluminum coating layer of the four OBFs and of the Thick Filter should have a thickness of  $\sim 30$  nm and  $\sim 70$  nm and  $\sim 100$  nm (for the Thick double side coated) spatially uniform to within  $\pm 3\%$  on spatial scales  $> 1$  cm<sup>2</sup> (TBC), and within  $\pm 10\%$  on spatial scales  $< 1$  cm<sup>2</sup> (TBC).

#### BBs to be procured:

- The same samples procured for T1 demonstrations.
- Small size meshless BBs with  $\sim 150$  nm thick polyimide film coated with 30 nm thick aluminum. These samples should be captured from one single PI/Al foil of the same size as the one produced for the large size representative breadboards.
- Small size meshless BBs with  $\sim 150$  nm thick polyimide film coated with 70 nm thick aluminum. These samples should be captured from one single PI/Al foil of the same size as the one produced for the large size representative breadboards.

	<h2>X-IFU FW Filters Technology Demonstration Plan</h2>	<p>DOC: XIFU-TN-UoG-0002  ISSUE: 1  DATE: 10/05/2022  PAGE: 19 of 30</p>
---	---	--

### Characterization tests:

- Visual inspection with a high resolution photographic optical scanner of all BBs procured in T1 with both polyimide film and Al coating aimed to search for defects and pinholes on the aluminum coating.
- Spatially resolved VIS/IR and/or X-Ray mapping of all small scale BBs procured to evaluate the spatial uniformity of the aluminum coating.
- Vibration tests to the four fully representative BBs to verify the stability of the Al adhesion onto the polyimide film. VIS/IR absorption spectroscopy will be performed before and after the vibration test on small sample areas. Visual inspections with a high resolution photographic optical scanner will be performed before and after each test.

### **7.4 T4 - Full size scale uniform and defect free bonding between plastic film and mesh**

The mesh/polyimide film adhesion shall be uniform and defect free. Glue spill outside the mesh area shall not significantly affect the overall blocking factor and cause stress concentration on the thin membrane.

### BBs to be procured:

- The same samples procured for T1 demonstrations.

### Characterization tests:

- Visual inspection of the four BBs with a high-resolution photographic optical scanner and an optical microscope, aimed to search for defects and irregularities in the mesh/polyimide film bonding.
- Surface Analysis (optical microscopy) on the BBs with representative meshes and thin polyimide film, to verify bonding quality between mesh and polyimide film including measuring the effect of glue spill on blocking factor.
- Thermo-vacuum between - 20 °C and 50 °C to verify the effects of thermal differential contraction between the bonded materials (mesh/glue/polyimide film). Visual inspections with a high resolution photographic optical scanner will be performed before and after each test.
- Vibration tests to verify the stability of mesh/film bonding over the large area. Visual inspections with a high resolution photographic optical scanner will be performed before and after each test.
- In order to magnify the presence of gluing defects between mesh and polyimide film, the BBs may be subject to moderate differential pressure (< 1 mbar).

	<h2>X-IFU FW Filters Technology Demonstration Plan</h2>	<p><b>DOC: XIFU-TN-UoG-0002</b>  <b>ISSUE: 1</b>  <b>DATE: 10/05/2022</b>  <b>PAGE: 20 of 30</b></p>
---	---	--

### 8 LIST OF BBs TO BE PROCURED AND TEST CHARACTERIZATION OF EACH TECHNOLOGY

Table 5 describes the BBs to be procured for the TRL5 demonstration. Table 6 identifies for each of the four critical technologies which characterization test must be performed on each BBs and when as also which pass/fail criteria is related to the requirements to be verified. Mechanical drawings of the BBs filter frame are provided in [RD10].

**Table 5 - List of BBs to be procured**

Sample code	Samples description	N samples
Thin OBF 1	Full scale BB of Thin OBF (aperture diameter: ~160 mm) with ~ 150 nm thick polyimide film coated with ~ 30 nm thick aluminum, glued on a fully representative Au plated BeCu mesh mounted on Al alloy AW6082 frame with 3.94% BF arm thickness 150 um and width 75 um	1
Thick OBF 1	Full scale BB of Thin OBF (aperture diameter: ~160 mm) with ~ 150 nm thick polyimide film coated with ~ 70 nm thick aluminum, glued on a fully representative Au plated BeCu mesh mounted on Al alloy AW6082 frame with 3.94% BF arm thickness 150 um and width 75 um	1
Thin OBF 2	Full scale BB of Thin OBF (aperture diameter: ~160 mm) with ~ 150 nm thick polyimide film coated with ~ 30 nm thick aluminum, glued on a fully representative Au plated BeCu mesh mounted on Al alloy AW6082 frame with 4% BF arm thickness 150 um and width 85 um	1
Thick OBF 2	Full scale BB of Thin OBF (aperture diameter: ~160 mm) with ~ 150 nm thick polyimide film coated with ~ 70 nm thick aluminum, glued on a fully representative Au plated BeCu mesh mounted on Al alloy AW6082 frame with 4% BF arm thickness 150 um and width 85 um	1
Small samples PI	Small size meshless samples mounted on standard TF110/TF111 LUXEL frames with ~ 150 nm thick polyimide film, captured from one single PI foil of the same size as the one produced for the large size OBF representative BBs.	7
Small samples PI/Al	Small size meshless samples mounted on standard TF110/TF111 LUXEL frames with ~ 150 nm thick polyimide film coated with aluminum (7 samples with 30 nm and 7 samples with 70 nm) captured from one single PI foil of the same size as the one produced for the large size OBF representative BBs.	14
Thin OBF PI/PI mesh	Full size X-IFU OBF with polyimide film of 140 nm coated with 30 nm of aluminum and supported by a polyimide mesh mounted on a X-IFU OBF frame with 160 mm clear aperture diameter.	1

 <b>UNIVERSITÉ DE GENÈVE</b> <small>FACULTÉ DES SCIENCES</small>		<h2>X-IFU FW Filters Technology Demonstration Plan</h2>	<b>DOC: XIFU-TN-UoG-0002</b> <b>ISSUE: 1</b> <b>DATE: 10/05/2022</b> <b>PAGE: 21 of 30</b>
			

Mesh Repr 1	A full scale BBs of the BeCu Au plated mesh (aperture diameter ~160 mm) with 3.94% BF with arm thickness 200 um and arm width 75 um (see Figure 6 for the drawing) provided by an European alternative manufacturer XRnanotech.	2
Mesh Repr 2	A full scale BBs of the BeCu Au plated mesh (aperture diameter ~160 mm) with 3.94% BF with arm thickness 250 um and arm width 85 um (see Figure 6 for the drawing) provided by an European alternative manufacturer XRnanotech.	2

**Table 6** - Table of test to be performed to demonstrate the technologies, samples to be subjected to each test and pass/fail criteria for each test

<b>T1 - Full size scale mesh with 4% blocking factor</b>			
Test	Sample code	Approx. period for test running	Pass/Fail criteria
Visual Inspection	<ul style="list-style-type: none"> <li>- Thin OBF 1</li> <li>- Medium OBF 1</li> <li>- Thin OBF 2</li> <li>- Medium OBF 2</li> <li>- Mesh Repr 1</li> <li>- Mesh Repr 2</li> </ul>	May - Oct. 2022	No major defects.
Surface Analysis (Opt. Microscopy, SEM)	<ul style="list-style-type: none"> <li>- Thin OBF 1</li> <li>- Medium OBF 1</li> <li>- Thin OBF 2</li> <li>- Medium OBF 2</li> <li>- Mesh Repr 1</li> <li>- Mesh Repr 2</li> </ul>	May - Oct. 2022	The mesh BF shall be within 10% (TBC) of nominal value. Mesh wire width shall be within 20% (TBC) of nominal value.
Thermo-vacuum	<ul style="list-style-type: none"> <li>- Thin OBF 1</li> <li>- Medium OBF 1</li> <li>- Thin OBF 2</li> <li>- Medium OBF 2</li> <li>- Mesh Repr 1</li> <li>- Mesh Repr 2</li> </ul>	May - Oct. 2022	No relevant effects of thermal differential contraction between mesh and frame as well as quality of plating adhesion.
Vibration	<ul style="list-style-type: none"> <li>- Thin OBF 1</li> <li>- Medium OBF 1</li> <li>- Thin OBF 2</li> <li>- Medium OBF 2</li> <li>- Mesh Repr 1</li> <li>- Mesh Repr 2</li> </ul>	May - Oct. 2022	No major defects occurred after vibration investigated by visual inspection. Stable Au and Ag plating quality verified by opt. microscopy/SEM before and after vibration tests.

		<h2>X-IFU FW Filters Technology Demonstration Plan</h2>	<p><b>DOC: XIFU-TN-UoG-0002</b>  <b>ISSUE: 1</b>  <b>DATE: 10/05/2022</b>  <b>PAGE: 22 of 30</b></p>
			

Differential pressure	<ul style="list-style-type: none"> <li>- Thin OBF 1</li> <li>- Medium OBF 1</li> <li>- Thin OBF 2</li> <li>- Medium OBF 2</li> </ul>	May - Oct. 2022	No damage nor plastic deformation of the mesh up to 5 mbar (TBC).
Differential pressure	<ul style="list-style-type: none"> <li>- Mesh Repr 1</li> <li>- Mesh Repr 2</li> </ul>	Jun.- Jul. 2022	No damage nor plastic deformation of the mesh up to 10 mbar (TBC). A ~1 µm thick polypropylene foil will be attached to the mesh frame in order to apply the differential pressure.

**T2 - Full size scale of thin polyimide foil**

Test	Sample code	Approx. period for test running	Pass/Fail criteria
Visual inspection	<ul style="list-style-type: none"> <li>- Thin OBF 1</li> <li>- Medium OBF 1</li> <li>- Thin OBF 2</li> <li>- Medium OBF 2</li> <li>- Small PI samples</li> <li>- Thin OBF PI/PI mesh</li> </ul>	May - Oct. 2022	Total pinholes area/Filter area < 10 <sup>-5</sup> . No major defects (TBD)
UV/X Absorption spectroscopy	<ul style="list-style-type: none"> <li>- Thin OBF 1</li> <li>- Medium OBF 1</li> <li>- Thin OBF 2</li> <li>- Medium OBF 2</li> <li>- Small PI samples</li> </ul>	May - Oct. 2022	PI spatial Uniformity within ± 3% on spatial scales > 1 cm <sup>2</sup> , and within ± 10% on spatial scales < 1 cm <sup>2</sup>
Differential pressure	<ul style="list-style-type: none"> <li>- Thin OBF 1</li> <li>- Medium OBF 1</li> <li>- Thin OBF 2</li> <li>- Medium OBF 2</li> </ul>	Jun.- Jul. 2022	No damage nor plastic deformation up to 5 mbar (TBC)

**T3 - Full size scale Al coating**

Test	Sample code	Approx. period for test running	Pass/Fail criteria
Visual inspection	<ul style="list-style-type: none"> <li>- Thin OBF 1</li> <li>- Medium OBF 1</li> <li>- Thin OBF 2</li> <li>- Medium OBF 2</li> <li>- Small PI/Al samples</li> <li>- Thin OBF PI/PI mesh</li> </ul>	May - Oct. 2022	Total pinholes area/Filter area < 10 <sup>-5</sup> . No major defects (TBD)

 <p>UNIVERSITÉ DE GENÈVE FACULTÉ DES SCIENCES</p>   	<h2>X-IFU FW Filters Technology Demonstration Plan</h2>	<p>DOC: XIFU-TN-UoG-0002 ISSUE: 1 DATE: 10/05/2022 PAGE: 23 of 30</p>
--	---	---

VIS/IR Absorption spectroscopy	<ul style="list-style-type: none"> <li>- Thin OBF 1</li> <li>- Medium OBF 1</li> <li>- Thin OBF 2</li> <li>- Medium OBF 2</li> <li>- Small PI/Al samples</li> </ul>	May - Oct. 2022	Al coating spatial Uniformity to within $\pm 3\%$ on spatial scales $> 1 \text{ cm}^2$ , and within $\pm 10\%$ on spatial scales $< 1 \text{ cm}^2$ .
Vibration tests	<ul style="list-style-type: none"> <li>- Thin OBF 1</li> <li>- Medium OBF 1</li> <li>- Thin OBF 2</li> <li>- Medium OBF 2</li> <li>- Thin OBF PI/PI mesh</li> </ul>	May - Oct. 2022	Vis/IR attenuation measured before and after the vibration tests shall not change by more than $10^{-4}$ (TBC).

**T4 - Full size scale uniform and defect free bonding between plastic film and mesh**

Test	Sample code	Approx. period for test running	Pass/Fail criteria
Visual inspection	<ul style="list-style-type: none"> <li>- Thin OBF 1</li> <li>- Medium OBF 1</li> <li>- Thin OBF 2</li> <li>- Medium OBF 2</li> </ul>	May - Oct. 2022	No major bonding defects
Surface Analysis (opt. microscopy)	<ul style="list-style-type: none"> <li>- Thin OBF 1</li> <li>- Medium OBF 1</li> <li>- Thin OBF 2</li> <li>- Medium OBF 2</li> </ul>	May - Oct. 2022	Glue spill shall not affect the mesh geometric BF by more than 10% (TBC) of nominal value. Glue spill shall be smooth to avoid stress concentration on the thin membrane.
Thermo-vacuum	<ul style="list-style-type: none"> <li>- Thin OBF 1</li> <li>- Medium OBF 1</li> <li>- Thin OBF 2</li> <li>- Medium OBF 2</li> </ul>	May - Oct. 2022	No relevant effects of thermal differential contraction between mesh and frame as well as quality of plating adhesion. Vis/IR attenuation measured before and after the thermo-vacuum tests shall not change by more than $10^{-4}$ (TBC).
Vibration tests	<ul style="list-style-type: none"> <li>- Thin OBF 1</li> <li>- Medium OBF 1</li> <li>- Thin OBF 2</li> <li>- Medium OBF 2</li> </ul>	May - Oct. 2022	No major defects occurred after vibration investigated by visual inspection.

### 9 Risk Mitigation Actions

As part of the risk mitigation actions, an investigation on new filter materials for future high-energy astrophysics missions (in particular for the large ESA mission Athena) aiming at developing a European expertise in a field largely dominated by US manufacturers will be performed.

Test filter samples of the European manufacturer company, Oxford Instruments will be procured to demonstrate the maturity of another technology. The tests aim to investigate the material optical and mechanical properties, to constrain model parameters, to support the design optimization, and to verify the compliance to the requirements. The filter manufacturing processes adopted by Oxford Instruments is different with respect to LUXEL. OXFORD Instruments built the film and the supporting mesh with the same plastic material (polyimide) by adopting a peculiar microlithography process. The main advantage of this technology lies in the perfect bonding between film and mesh avoiding the use of any glue. For this reason the T4 TECHNOLOGY listed in the Introduction “Full size scale uniform and defect free bonding between plastic film and mesh” do not have to be demonstrated for these filters to reach TRL5.

Should these alternative technologies demonstrate to be mature to TRL5 and advantageous with respect to the current baseline, a change of the design will be evaluated before the end of phase B. Only in this case, the test results on the alternative materials and related documentation will enter into the configuration control of the Athena X-IFU development program.

### 10 Planning

Figure 8 shows the schedule of BBs procurement and tests needed to demonstrate TRL5.

	2021		2022											
	No v	De c	Jan	Fe b	Ma r	Apr	Ma y	Jun	Jul	Au g	Se p	Oct	No v	De c
<b>Procurement and tests</b>														
BBs Procurement														
Visual inspection														
UV/X Absorption spectroscopy														
Vibration tests														
Differential pressure														

Fig. 8 - TRL5 demonstration activity schedule.

	<h2>X-IFU FW Filters Technology Demonstration Plan</h2>	<p>DOC: XIFU-TN-UoG-0002  ISSUE: 1  DATE: 10/05/2022  PAGE: 25 of 30</p>
---	---	--

## 11 Facilities description

### 11.1 Visual Inspection

A high resolution photographic scanner EPSON Perfection V850 Pro inside a ISO7 cleanroom to examine in detail the filter surfaces. Provided that a contrast material is deposited on the film (e.g. metal coating) pinholes with sizes down to 10  $\mu\text{m}$  diameter can be detected, and their number and position on the filter can be recorded. A Leica optical microscope can be used to better examine identified pinholes and defects. Figure 9 right panel shows a picture of a small portion ( $\sim 10\text{ mm} \times 10\text{ mm}$ ) of a test filter consisting of a polypropylene film 600 nm thick coated with titanium 40 nm thick supported by a SS AISI 304 mesh (pitch = 6 mm, wire width = 100  $\mu\text{m}$ ). The left panel is a zoom on a pinhole with  $< 30\text{ }\mu\text{m}$  diameter also identified in the picture shown in the right panel.

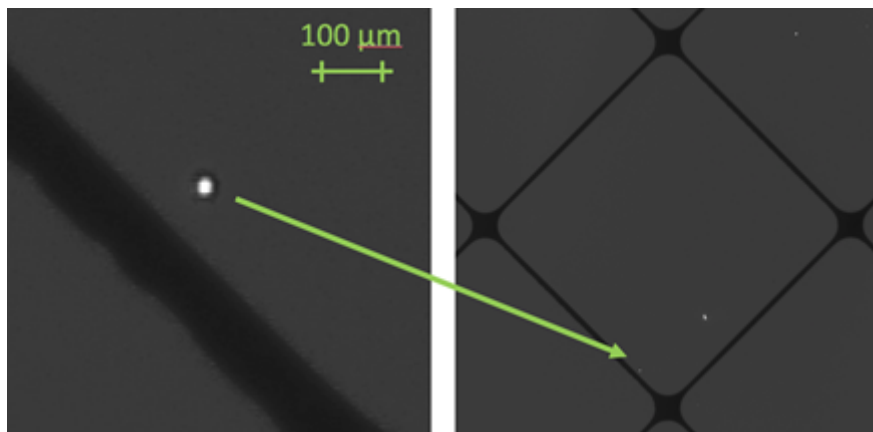

Fig. 9 - Scanner image of a sample test filter with pinholes.

### 11.2 Surface Analysis

SEM images can be acquired at the ATeN Center, UNIPA, by a SEM QUANTA 200 FEI field emission gun (FEG) Environmental Scanning Electron Microscope (ESEM) to investigate the surface morphology at high magnification. This instrument is equipped with an X-ray energy dispersive spectrometer (EDS) to investigate chemical composition. This experimental technique will be used mainly to investigate the quality of bare meshes, the plating applied on them as well as glue spills outside the mesh area.

### 11.3 X-ray Absorption spectroscopy

High spectral resolution transmission measurements will be performed in three different synchrotron facilities, namely ELETTRA (Trieste, Italy), BESSY II (Berlin, Germany) and SOLEIL (Paris, France) will be. The energy range investigated includes edges of the elements present in

the filter: Al L-edges @73 eV and @118 eV, C K-edge @283 eV, N K-edge @402 eV, O K-edge @532 eV, and Al K-edge @1560 eV.

We plan to perform the X-ray transmission measurements at ELETTRA synchrotron at BEAR beamline, in the energy range between 45 eV and 1600 eV, with an energy step of 0.1 eV on the whole range. A scheme of the experimental set up is reported in Figure 10.

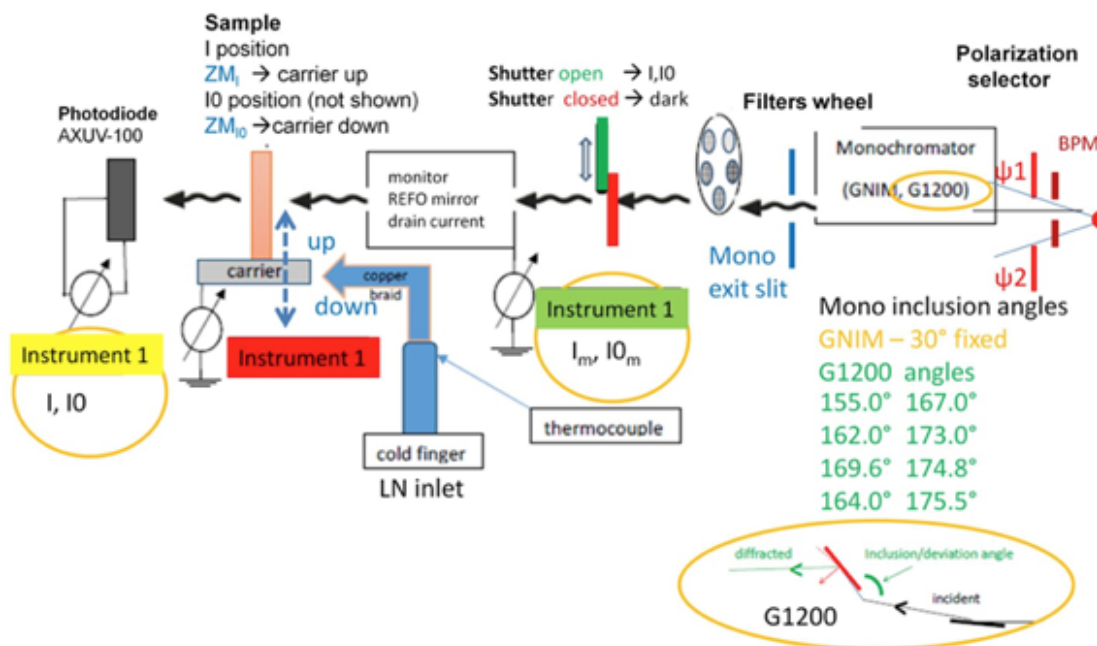

**Fig. 10.** - BEAR beamline at ELETTRA experimental set up: light source (red dot, to the right); beam position monitor (BPM), polarization selector, monochromator, exit slit, filters wheel, shutter (open/close), intensity monitor, sample, sample carrier ZM up/down to measure I (transmitted intensity) and IO (incident intensity), light detector. Monochromator inclusion/deviation angles are shown in the inset for G1200. The LN2 sample cooling system is also sketched.

The X-ray transmission measurements at BESSY II synchrotron will be performed at PTB-EUV beamline, in the energy range between 50 eV and 1800 eV. The schematic of the beamline is reported in Figure 11.

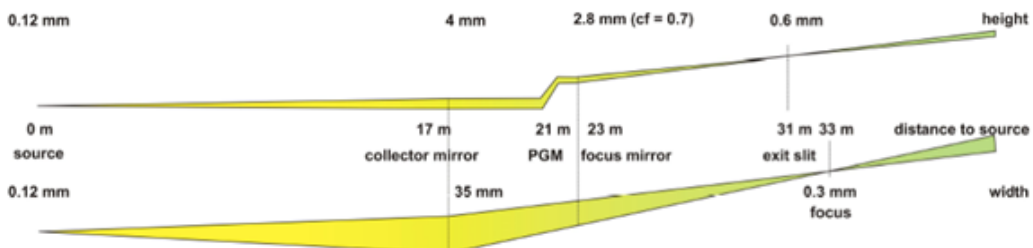

	<h2>X-IFU FW Filters Technology Demonstration Plan</h2>	<p>DOC: XIFU-TN-UoG-0002  ISSUE: 1  DATE: 10/05/2022  PAGE: 27 of 30</p>
---	---	--

**Fig. 11.** - Scheme of the PTB-EUV soft X-ray beamline @BESSY II (top: side view, bottom: top view). After entrance aperture (left), the horizontal and the vertical direction of the beamline are treated differently. In the horizontal, the collector mirror focuses the beam into the experiment. In the vertical, the collector mirror collimates the beam in front of the plane-grating monochromator. Behind the monochromator, the beam is vertically focused into the exit slit. Spectral purity filters for blocking higher diffraction orders from the grating of the monochromator can be introduced into the beam between the exit slit and the experiment. Crossed aperture blades at the entrance of the experiment chamber are used to block any stray light.

### 11.4 UV/VIS/NIR Transmission

UV/VIS/NIR characterization can be performed using a Perkin-Elmer lambda1050 double beam spectrophotometer. The instrument allows both transmission and reflection measurements. Transmission measurements can be acquired in the  $17.5 \div 3300$  nm with a monochromator bandwidth  $0.05 \div 5$  nm in the UV/VIS region and  $0.2 \div 20$  nm in the NIR region. Nitrogen flux is required in the 175-190 nm range. The instrument is equipped with a software-controlled 2D stage to map large samples in transmission mode, the area that can be investigated is up to 90 mm x 90 mm.

Reflection measurements can be carried out using an auto-aligned 3-ports integrating sphere (diameter = 100 mm) with internal coating in Spectralon. The sphere is equipped with dedicated PMT and PbS detectors that collect data in the  $190 \div 2500$  nm range. The wavelength accuracy is 0.025 nm and 0.200 nm in the UV/VIS and the NIR, respectively. The photometric noise and the photometric stability are  $\leq 0.00004$  Absorbance at Absorbance = 0 and  $\leq 0.00006$  Absorbance, respectively. The photometric range reaches 8 Absorbance allowing to characterize highly absorbing samples.

EUV transmission measurements can be performed at the BEAR beamline in ELETTRA in the energy range 5-40 eV (30 - 250 nm) using the plane grating GNIM with 1200 //mm.

### 11.5 Bulge test (differential pressure)

Static pressure load tests can be used to validate performances, measuring the deflection under differential pressure. The experiment can be performed at the XACT Facility of INAF-OAPA. The experimental setup adopted for these tests includes a XY-translator to scan the OBF, an optical sensor to measure the film deflection, a sample holder, and a pressuring system to apply and measure the differential pressure (see Figure 12). The filter is mounted on a custom sample holder, sealed on the filter frame with an o-ring to allow the pressurization of the bottom face. The sample

holder is attached to the computer controlled translator, which moves the bulged filter for measuring the membrane profiles with the sensor.

The pressuring system adopts a precise electronic pressure regulator (Equilibar model QPV) and a couple of pressure reducer valves (at high and low-pressure stages) connected to a pressurized nitrogen tank. The pressuring system allows to compensate for gas leaks, regulating the set pressure with an accuracy of 0.17 mbar. The scanning of the sample is performed along one symmetry axis of the filter while the differential pressure is kept constant for all the duration of the acquisition. The displacement measurement system is a Micro-epsilon® optical confocal sensor, model DT 2421/2422.

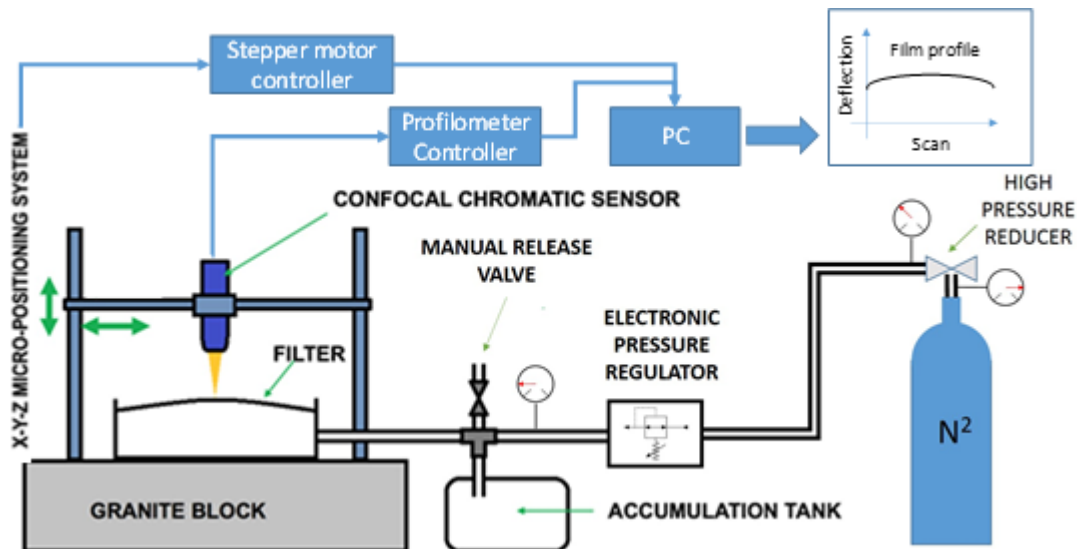

**Fig. 12** - Schematic drawing of the realized device to measure the filter deformation under static differential pressure load.

The optical resolution of the Micro-epsilon® probe is 60 nm, its measurement field is 10 mm, and the maximum sampling rate is 6.5 kHz. Measured data is acquired by a personal computer. The system has been validated on submicron polyimide film, CNT pellicles and larger polypropylene films coated with Ti and supported by metal meshes.

## 11.6 Vibrational Tests

Vibrational tests will be performed using the shakers available at one of the following research centers:

1. Centre Spatial de Liege (CSL), Liege, Belgium;
2. Max-Planck Institute for Extraterrestrial Physics, Garching, Germany (collaboration with MPE on the ATHENA WFI filters development);
3. SERMS srl, Terni (TR), Italy.

## 11.7 Thermo-vacuum

Thermo-vacuum cycles of larger size filters will be tested in a new cryostat recently set-up at INAF-OAPA. Figure 13 shows a picture of the experimental thermo-vacuum setup. The setup can run thermal cycling under high-vacuum on samples up to 150 mm diameter, between 10 K and 350 K.

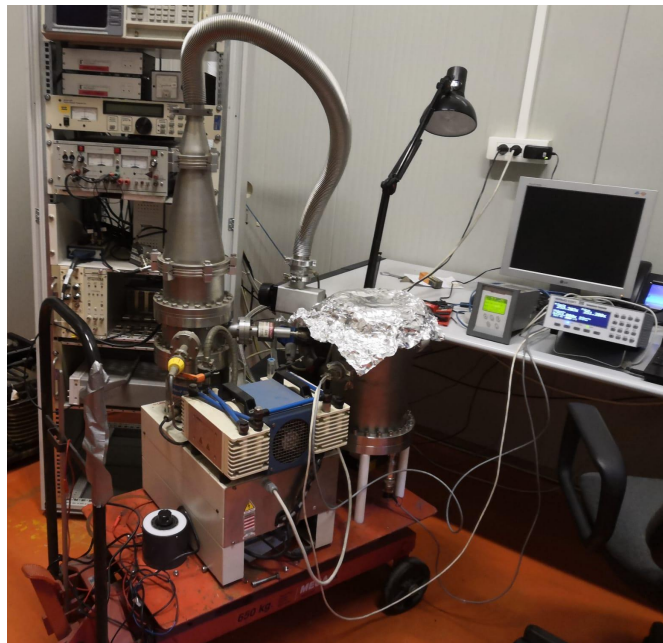

Fig. 13 - Picture of the set-up of thermo-vacuum measurements.

A schematic drawing of the cryostat is reported in Figure 14.

# X-IFU FW Filters Technology Demonstration Plan

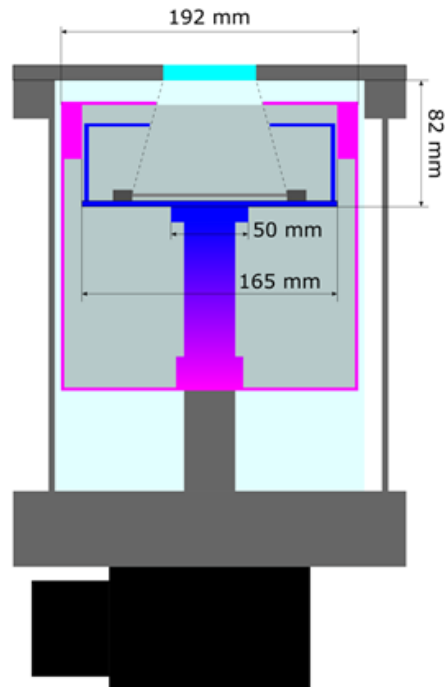

Fig. 14 - Schematic drawing of the cryostat for thermo-vacuum tests of large size filter samples.